



SITE MANAGEMENT PLAN

(NCRWQCB Water Resource Protection Plan)

In fulfillment of
Order WQ 2017-0023-DWQ & NCRWQCB order Order No. 2015-0023
General Waste Discharge Requirements and Waiver of Waste Discharge
Requirements for Discharges of Waste Associated with Cannabis Cultivation
Activities

Prepared for:

Lost Coast Lady Farms, LLC

and

State Water Resources Control Board

State Registration #417598
Tier 1, High Risk Discharger
WDID: 1B171193CHUM, Tier 2

Prepared by:



Peter Hill
Peter@NorthPointEureka.com
707-798-6438

Revised May 2018

TABLE OF CONTENTS

INTRODUCTION

SITE INFORMATION

TIER AND RISK DESIGNATION

BEST PRACTICAL TREATMENT OR CONTROL (BPTC) MEASURES

1. Sediment Discharge Measures
 - 1.1. Site Characteristics
 - 1.1.2. Road Conditions
 - 1.1.3. Water Bodies, Stream Crossings, Riparian Setbacks
 - 1.1.4. Soil Disturbance
 - 1.2. Sediment Erosion Preventions and Sediment Capture
 - 1.2.1 Erosion Prevention BPTC Measures
 - 1.2.1.1. Roads
 - 1.2.1.2. Disturbed Areas
 - 1.2.1.3. Streams and Stream Crossings
 - 1.2.1.4. Winterization
 - 1.2.2. Sediment Capture BPTC Measures
 - 1.2.2.1. Roads, Stream Crossings, and Soil Disturbance
 - 1.2.3. Maintenance Activities – Erosion Prevention and Sediment Control
 - 1.2.3.1. Monitoring
 - 1.2.3.2. Maintenance
2. Fertilizer, Pesticide, Herbicide, and Rodenticide BPTC Measures
 - 2.1. Cultivation Product Storage, Use, and Disposal
 - 2.1.1. Storage
 - 2.1.2. Application
 - 2.1.3. Disposal and Spill Prevention/Cleanup
3. Petroleum Product BPTC Measures
 - 3.1 Petroleum Storage, Use, and Disposal
 - 3.1.1. Storage
 - 3.1.2. Application
 - 3.1.3. Disposal and Spill Prevention/ Cleanup
4. Trash/Refuse and Domestic Wastewater BPTC Measures
 - 4.1. Household Trash and Cultivation-related Waste
 - 4.2. Residents, Employees, and Visitors
 - 4.2.1. Domestic Wastewater – Generation
 - 4.2.2. Domestic Wastewater – Disposal

5. Winterization BPTC Measures

5.1. Activities and Maintenance

5.1.1. Roads and Stream Crossings

5.1.2. Disturbed Areas

5.1.3. Storage and Stockpiled Materials

5.1.3.1. Cultivation-related Products and Waste

5.1.3.2. Vehicles, Machines, and Petroleum Products/Waste

5.1.3.3. Stockpiled Materials

APPENDICIES

Appendix A: Site Map

Appendix B: Disturbed Area Map

Appendix C: BPTC Implementation and Maintenance Schedule

Appendix D: BPTC Measure Specifications

Appendix E: References

Appendix F: Water Use Records

Appendix G: Fertilizer, Pesticide, Herbicide, and Rodenticide Product List and Records

Appendix H: Monthly BPTC Monitoring and Maintenance Records

Appendix I: Monthly PH and Turbidity Monitoring Records (Moderate and High Risk)

INTRODUCTION

This Site Management Plan (SMP)/Water Resource Protection Plan (WRPP) has been developed to satisfy conditions of the Tier 2 enrollment requirements in the State Water Resource Control Board (SWRCB) Order No. WQ 2017-0023-DWQ (Order), and Order No. 2015-0023 for the North Coast Regional Water Quality Control Board (NCRWQCB). The purpose of the Order is to implement the Cannabis Policy requirements for waste discharges associated with cannabis cultivation. The Policy provides a structure for managing water quality and instream flow impacts associated with cannabis cultivation. It also establishes criteria for personal use and site conditional exemptions and includes a tiered approach for permitting discharges of waste. All eligible dischargers developing land for cannabis cultivation activities are required to enroll in the program under the Order. Dischargers must implement Best Practical Treatment or Control (BPTC) measures and submit technical and monitoring reports to assure compliance with the Order. The SMP describes how the discharger is complying with the applicable BPTC measures listed in the Policy and how they are being implemented property-wide.

SITE INFORMATION

Registrant: Lost Coast Lady Farms, LLC
998 11th Street
Arcata, CA 95521

Site Address: 33856 Mattole Road
Petrolia, CA 95558

Parcel: Assessor Parcel Number: 105-131-005 & 105-131-006
Lat/Long: 40.2805°, -124.2502°

Zoning: General Plan: Agriculture
Zone: Agriculture Exclusive (AE)

Acres: Approximately 3.30 (APN: 105-131-005) and 0.74 (APN: 105-131-006) acres (Humboldt County WebGIS)

Disturbed Area: Approximately. 0.28 acres

Location: The project site is in the Petrolia area, approximately 50 miles south of Eureka. To reach the site from Eureka, take US-101 south for 15 miles to exit 692 toward Ferndale/Fernbridge. Continue on Fernbridge Dr. for .5 miles. Turn right onto CA-211 S for 4.1 miles. Right for 0.3 miles on Arlington Ave and left onto 5th street for 0.6 miles. Right on Ocean Avenue for 115 feet and then left onto Wildcat Ave for 0.2 miles. Right

onto Mattole Rd for approximately 30 miles. Project Driveway will be on you right.

Site Description: The project is located in the Mattole Watershed on 4.3 acres. The site is at an elevation of 200 feet with a class II watercourse flowing east to west just to the north of the property line. The Mattole river is approximately 350 feet from the site. The property is relatively flat with slopes at approximately 15%. The surrounding parcels are timber to the west and agricultural fields east before the Mattole River.

TIER AND RISK DESIGNATION

The Cannabis Policy provides criteria for evaluating threats to water quality for cannabis cultivation sites based on three site characteristics: proximity to water body, total disturbed area, and slope of the disturbed area. Based on the criteria and site characteristics the subject property is designated as a **Tier 1 Discharger**. The total disturbed area is 11,120 ft², which is equal to 0.26 acres (Table 1).

Table 1: Disturbed Area Size, Slopes, and Setbacks

| Disturbed Area Type | Area (ft ²) | Disturbed Area Slope | Distance to Water Body (ft.) | Water Body Type |
|-----------------------------|-------------------------|----------------------|------------------------------|-------------------|
| Cultivation Area 1 | 2,500 | 8% | 35 | Class II Drainage |
| Cultivation Area 2 | 3,000 | 9% | 140 | Class II Drainage |
| Cultivation Area 3 | 2,750 | 7% | 370 | Class II Drainage |
| Drying Shed | 240 | 8% | 50 | Class II Drainage |
| Conex Box | 400 | 8% | 60 | Class II Drainage |
| Residence | 1,125 | 8% | 70 | Class II Drainage |
| Accessory Residence | 240 | 6% | 310 | Class II Drainage |
| Shed #2 | 384 | 6% | 330 | Class II Drainage |
| Shed #3 | 131 | 5% | 400 | Class II Drainage |
| Shed #4 | 131 | 5% | 400 | Class II Drainage |
| Spent Soil | 144 | 5% | 400 | Class II Drainage |
| Water tank 2.5k | 25 | 10% | 10 | Class II Drainage |
| Water tank 1.5k | 25 | 8% | 40 | Class II Drainage |
| Water tank 2.5k | 25 | 8% | 140 | Class II Drainage |
| Total Disturbed Area | 11,120 | | | |

The main entrance road is located off Mattole Road. Mattole Road is a paved and striped county maintain road. The 300 feet of driveway was originally established for the site residence in 2004 before cannabis activity. Thus, the area of the road network is not included in the total disturbed area. See the disturbed area map in Appendix B for specific areas included in the disturbed area.

In addition, a risk designation is assigned based on the slope of the disturbed areas and proximity to a waterbody. Based on these parameters, the subject property is designated as a **High Risk**. The total disturbed area of 0.26 acres and 2,500 square feet cultivation remains inside of the riparian setback requirements and on slopes less than 15 percent.

BEST PRACTICAL TREATMENT OR CONTROL (BPTC) MEASURES

BPTC measures are being utilized as part of the road maintenance program to protect water quality. The *Solid Waste Management, Construction Site Best Management Practices Manual* by the CA Department of Transportation (Caltrans) is referenced for the correct installation, maintenance, and monitoring of all applicable erosion control and sediment capture BPTC measures.

All straw mulch must be free of noxious weeds and all seed/plants must be non-invasive. A list of prohibited species can be found in the CA Invasive Plant Council's database. Erosion control measures shall not include synthetic monofilament netting, including photo- and biodegradable plastic netting. All netting shall be made of jute, coir fiber, hemp, or another product without welded weaves.

A schedule of BPTC measures to be implemented and maintained throughout the site is shown in Appendix C, and Appendix D includes specifications for BPTCs.

1. SEDIMENT DISCHARGE BPTC MEASURES

1.1. SITE CHARACTERISTICS

1.1.1. SITE MAP

The site map shows all relevant site features: streams, stream crossings, storage areas, roads, buildings, domestic wastewater treatment system, cultivation areas, and other disturbed areas related to cultivation activities. Erosion prevention and sediment control BPTC measures are identified on the map (see Appendix A).

1.1.2. ROAD CONDITIONS

The main entrance road receives an average of two daily vehicle trips in the peak season (May - October) and less than one vehicle trips in the winter season. The entry road is constructed on a flat gradient and the

road surface consists of a compact surface with loose gravel. There is little too no ruts or rills except for the need for a rolling dip just before exiting the parcel. Much of the road is slightly sloped toward the southern agricultural field. Currently, road maintenance activities consist of adding additional rock when necessary. Additional road maintenance is prescribed in section 1.2.1.

1.1.3. WATER BODIES, STREAM CROSSINGS, RIPARIAN SETBACKS

There are zero stream crossing on site. The class II watercourse the flow into the Mattole River runs west to east on the northern property line.

This site consists of three cultivation areas. The first cultivation area is 2,500 square feet and is 35 feet from the bank of the class II watercourse. The cultivation area is separated by a berm and cinderblocks and does not pose a high threat to water quality. This second cultivation area on parcel 005 is approximately 3,000 square feet and is outside of all riparian setbacks. The third cultivation area is approximately 2,750 square feet and is outside of all riparian setbacks.

Currently structures in the riparian setbacks that are used for cannabis cultivation included a carport for storage and metal shipping container acting as a nursery for propagation. Both are proposed to be relocated to the southern side of the parcel. The two water tanks that are in the riparian zone will be relocated outside of the 100-foot riparian buffer.

1.1.4. SOIL DISTURBANCE

The site has no areas of active soil disturbance. All historic graded areas are stable and vegetated, and there are no active slides or earth movement on site.

1.2. SEDIMENT EROSION PREVENTION AND SEDIMENT CAPTURE

1.2.1. EROSION PREVENTION BPTC MEASURES

1.2.1.1. ROADS

A rolling dip will need to be installed at the RD-1 on the site map. The rolling dip will discourage concentrated flow down the road towards the class II watercourse. The dip will be outsloped towards the agricultural field at approximately 3 to 5 percent and rocked. When necessary the road surface will be rocked with road base and a top dressing can be applied to prolong road surface.

Erosion prevention measures roads will be implemented during the dry summer months. The road construction standards described in the "Road Handbook" will be adhered to for all road improvements. See Appendix C for the Schedule of BPTC Implementation and Maintenance.

1.2.1.2. DISTURBED AREAS

All exposed soil in disturbed areas will be seeded and mulched with straw and existing live mulch will be maintained. Any areas for planned disturbance/development will be surveyed for sensitive species, wildlife, and communities, and CDFW shall be consulted with to designate a no-disturbance buffer if necessary.

1.2.1.3. STREAMS AND STREAM CROSSINGS

There is no proposed or existing stream crossing on site.

1.2.1.4. WINTERIZATION

Winterization measures will be implemented annually by November 1st and interim erosion prevention BPTC measures will be utilized as needed throughout the year. To prevent erosion and sediment transport to streams, numerous measures for soil stabilization, runoff management, erosion and sediment prevention/retention are utilized throughout the seasonally dry period and prior to the onset of winter. Section 5 “Winterization BPTC Measures” has more information on proposed actions to protect water quality in the winter season.

1.2.2. SEDIMENT CAPTURE BPTC MEASURES

1.2.2.1. ROADS, STREAM CROSSINGS, AND SOIL DISTURBANCE

Used soil are stacked, piled, and left in 15 to 25 plastic bags. The soil is stored on the south side of the 16’x24’ shed approximately 375 feet from the class II watercourse. Soil and cultivation waste will need to be covered with tarps and fiber rolls installed around the area. Any future spoils will be placed in the designated area where they cannot be transported to surface water. Any slash shall be removed, chipped, or burned at the appropriate times with the proper burn permit.

Stockpiled materials for construction and road maintenance will be stored in stable locations and contained using appropriate BPTC measures. Other sediment control measures may be installed as needed to prevent discharges from entering waters of the state. See Appendix C for the schedule of all sediment control BPTC measures being employed on site.

1.2.3. MAINTENANCE ACTIVITIES – EROSION PREVENTION AND SEDIMENT CAPTURE

1.2.3.1. MONITORING

The rolling dip and the entrance to the property should be monitored to ensure the disconnect of the site’s road and the class II watercourse. All long-term and interim erosion prevention and sediment capture BPTC measures that have been implemented will

be monitored for effectiveness on a monthly basis at a minimum (Table 1.2.3.1). Any vegetation planted on previously disturbed areas will be monitored for success and replanted if necessary. The cultivator will monitor erosion and sediment control measures during and after each storm event that produces at least 0.5 in/day or 1 in/7 days of precipitation. In addition, winterization measures that are implemented will be monitored for effectiveness (inspected during the first major winter storm event) before the site is closed for the winter. See Appendix H for a log of monthly BPTC monitoring and maintenance records.

Table 1.2.3.1. BPTC Effectiveness Monitoring

| Observations | Description | Monitoring Frequency |
|--|--|---|
| Erosion Prevention and Sediment Capture Maintenance | Report activities for maintaining the effectiveness of erosion prevention and sediment retention/capture measures | Monthly |
| Active Erosion | Report any indications of soil erosion | Monthly |
| Surface Water Runoff Maintenance | Report the conditions of any surface water (stormwater, irrigation) and include the location, source of runoff, duration | Monthly |
| Stormwater Runoff Constituents | Turbidity – conduct sampling once per month when precipitation exceeds 0.25 in/day or when stormwater runoff is generated on site pH – conduct sampling once per month when precipitation is forecast to exceed 0.25 in/day | Every month until winterization procedures are completed. |
| Disturbed Area Stabilization | High risk dischargers shall provide a status report describing activities conducted to stabilize the disturbed area with the setback | Monthly |
| Materials Storage Erosion/Spills Prevention | Report materials delivered or stored on site that have the potential to degrade water quality if discharged | Monthly |
| Septic, Holding Tank, or Chemical Toilet Servicing | Report the name of the servicing company, dates, and activity | Monthly |

1.2.3.2. MAINTENANCE

Year-round maintenance of all erosion prevention and sediment capture measures is required. All existing measures shall be maintained, repaired, or replaced as needed. Exotic or invasive species found in revegetated or disturbed areas shall be removed. Remaining exposed soil shall be reseeded/revegetated and have 2-4" of weed-free mulch reapplied. Any captured sediment in inboard ditches/drainageways, culvert outfalls, or against silt fences/straw wattles will be removed and stabilized on a designated flat area. The sediment may be used for site improvement where it will not threaten water quality. Interim measures for sediment retention, such as mulching and wattling, require more regular monitoring and maintenance. See Appendix H for a log of monthly BPTC monitoring and maintenance records.

2. FERTILIZER, PESTICIDE, HERBICIDE, AND RODENTICIDE BPTC MEASURES

2.1. CULTIVATION PRODUCT STORAGE, USE, AND DISPOSAL

2.1.1. STORAGE

Pesticides and fertilizers are being stored in Shed #3. The shed is covered and enclosed. Fertilizers and pesticides are being stored in a separate location from petroleum products. No rodenticides are currently being used on site. At the end of the season, any unused liquid products are stored in secondary containment within the shed and applied the following year (see Site Map in Appendix A for storage locations). Soil and fertilizers may temporarily be stored in or near the greenhouses prior to being applied.

Appropriate BPTC measures are being utilized when storing, handling, mixing, applying, and disposing of all fertilizers, pesticides, herbicides, and rodenticides. Each year an inventory is conducted prior to the beginning of the grow season and necessary products are delivered to the site as needed. See Appendix G for a list of fertilizers and pesticides/herbicides used on site.

2.1.2. APPLICATION

Mixing of fertilizers in small storage tanks is conducted in a designated area where the mix will not enter surface waters. The mix is applied via watering wand and fertigated at agronomic rates. Spent soil is amended and reused as needed. The application of any agricultural chemical products will be conducted according to the manufacturer's recommendation.

2.1.3. DISPOSAL AND SPILL PREVENTION/CLEANUP

Trash and recycling containers are located near the existing residence and are contained to prevent surface water contamination and wildlife

intrusion. Excess soil not slated to be reused or mulched will be disposed of properly along with other cultivation products, and the disturbed area will be seeded and covered with straw to prevent erosion. Spent product containers are carefully transferred from the mixing area to the refuse area. A spill kit with plenty of sorbent pads is kept on site in the event of a spill. All trash, empty product containers, and other recycling are hauled off-site bi-weekly to the Petrolia waste management facility.

3. PETROLEUM PRODUCT BPTC MEASURES

3.1. PETROLEUM STORAGE, USE, AND DISPOSAL

Table 3.1. Petroleum Product List, Storage, and Use

| Petroleum Product | Delivery Period | Storage Method | Use Type |
|-------------------|---|---|---|
| Gasoline | As needed throughout the growing season (April - October) | 5-gallon plastic petroleum storage tanks | Generators, farm tools, maintenance equipment |
| Propane Tank | As needed throughout the year | (3) 5-gallon & (2) 7-gallon metal propane tanks | Heating/cooking for the house |
| Lubricants | As needed throughout the year | In storage shed within secondary containment | Equipment maintenance |

3.1.1 STORAGE

The discharger has a couple five-gallon fuel containers for the backup generator and farm tools (weed eaters, lawn mower, etc). The five-gallon containers are stored in Shed #2 with in secondary containment (see site map in Appendix A). There are five propane tanks stored in a shed near the residence. The five tanks include three 5-gallon tanks and two 7-gallon tanks. Smaller 5-gallon gas cans, lubricants, and other petroleum products are being stored in secondary containment when not in use. The generator will only be used as a backup when on grid power is out. The generator has a drip pan and is being stored in a shed behind the residence. Vehicles and machines are regularly monitored for leakage and when not in use are being stored in a location outside riparian setback.

3.1.2. APPLICATION

Fueling and maintenance of the generators, cars, and other machines is being conducted in a designated area that prohibits discharge to waters of the state.

3.1.3. DISPOSAL AND SPILL PREVENTION/CLEANUP

Special care is taken when transporting and handling all petroleum products. Spill prevention/cleanup BPTC measures are being utilized; a spill kit with plenty of sorbent pads is kept on site in the event of a spill. Spent petroleum products and related trash are kept in secondary containment, specifically for hazardous waste, before being transferred to the waste management facility.

4. **TRASH/REFUSE AND DOMESTIC WASTEWATER BPTC MEASURES**

4.1. HOUSEHOLD TRASH AND CULTIVATION-RELATED WASTE

All trash/refuse generated on site will be kept in a designated area near the residence (see site map in Appendix A) where it will not migrate or leach into waters of the state. Cultivation-related organic waste is composted in a designated area and stabilized with the appropriate BPTC measures. Spent potting soil is stored in a secure location and stabilized using appropriate sediment control BPTC measures. Household and other cultivation-related waste and recycling are temporarily stored in wildlife-impenetrable storage containers. All refuse and cultivation waste are then transported to the Petrolia waste management facility approximately twice a month.

4.2. RESIDENTS, EMPLOYEES, AND VISITORS

Approximately 2 residents are on site during the growing season, and a maximum of 3 employees are on site during the peak operation season. The 2 residents live part time on site in the winter season. No visitors come to the site.

4.2.1 DOMESTIC WASTEWATER - GENERATION

The household produces greywater from the kitchen sink, and there is an existing septic system that is unpermitted. The septic system appears to be functioning properly and has been pumped in recent years. A septic investigation will need to be completed and a permit from the Humboldt County Division of Environmental Health.

4.2.2 DOMESTIC WASTEWATER - DISPOSAL

Household greywater from the kitchen sink drains into the leach field. There is an unpermitted septic tank and leach field (identified on site map). The property owner is in the process of applying for a septic permit and should receive approval within 2 years (October 2019). See the site map in Appendix A for locations of wastewater treatment locations. The cultivator shall make sure that no substances that are hazardous to fish and wildlife (e.g. trash, paint, concrete washings, treated wood) are used, located, or disposed of where they can contaminate waters of the state. Human and animal waste shall also be disposed of properly.

5. WINTERIZATION BPTC MEASURES

5.1. ACTIVITIES AND MAINTENANCE

5.1.1 ROADS AND STREAM CROSSINGS

Appropriate erosion prevention and sediment control measures will be installed, maintained, and monitored for effectiveness prior to the winter season. Road work requiring heavy machinery, such as outslipping, shall be conducted only during the dry season, unless the cultivator is authorized by an agency with jurisdiction to make emergency repairs. Temporary access roads also need to be closed to traffic prior to the onset of winter. The main access road has excessive sheet flow lengths that will be improved by outslipping and rolling dips. Winterization of the main access road includes temporary and long-term runoff management and soil stabilization measures, such as the rocking of inboard ditches, installing check dams, and stream inlet protection. All winterization BPTC measures will be monitored and maintained prior to site closure for the winter. Culverts will be inspected for erosion or clogging prior to and after a significant storm event. Any debris and sediment found to be clogging culverts, inlets/outlets, or drainageways will be removed and appropriately stored, reused, or disposed of.

5.1.2. DISTURBED AREAS

Areas that have exposed soil shall be seeded/hydroseeded and mulched to prevent erosion and sediment delivery to a waterbody. Any revegetation shall take place at the onset or at the end of the precipitation season to ensure establishment. Exposed slopes shall have linear sediment controls, such as wattles or silt fences, to interrupt sheet flow lengths. All disturbed areas will be inspected for potential and active erosion issues. Such sites will be repaired/controlled as needed using appropriate BPTC measures. For all areas of concern, if any BPTC measures cannot be installed prior to winter, the Regional Water Board must be contacted to establish a compliance schedule to protect water quality.

5.1.3. STORAGE AND STOCKPILED MATERIALS

5.1.3.1. CULTIVATION-RELATED PRODUCTS AND WASTE

All fertilizers, pesticides, herbicides, and rodenticides need to be stored where they will not enter surface waters or pose a threat to wildlife. The cultivator will have all liquid products stored in secondary containment and stored along with all other cultivation-related products, protected from the elements. Waste associated with cultivation will be removed from the site and taken to the Petrolia waste management facility prior to closing the site for winter.

5.1.3.2. VEHICLES, MACHINES, AND PETROLEUM PRODUCTS/WASTE

Prior to winter, any remaining vehicles or machines on-site will be stored out of the elements where any potential leaks will not enter surface waters or pose a threat to wildlife. The generator shed will also be locked to prevent wildlife intrusion. Petroleum products will be kept in compatible secondary containment within their own storage container. Any spent petroleum containers and related trash will be removed and appropriately disposed of at the Petrolia waste management facility.

5.1.3.3. STOCKPILED MATERIALS

Appropriate BPTC measures shall be used for all stockpiled materials that have the potential to migrate to surface waters or that may be hazardous to wildlife. Stockpiled materials include bark, sawdust, potting soil, amendments, rock, compost, treated wood, polytube and other irrigation equipment, greenhouse plastic sheeting, and any other materials used for cultivation and site development, improvement, and management. They shall be stabilized in an upland area, covered, and/or stored in a storage shed/container.

DISTURBED AREA STABILIZATION PLAN

(NCRWQCB Water Resource Protection Plan)

In fulfillment of
Order WQ 2017-0023-DWQ & NCRWQCB order Order No. 2015-0023
General Waste Discharge Requirements and Waiver of Waste Discharge
Requirements for Discharges of Waste Associated with Cannabis Cultivation
Activities

Prepared for:
Lost Coast Lady Farms, LLC
and
State Water Resources Control Board

State Registration #417598
Tier 1, High Risk Discharger
WDID: 1B171193CHUM, Tier 2

Prepared by:



Derek Roelle
Derek@NorthPointEureka.com
707-798-6438
Revised May 2018

TABLE OF CONTENTS

INTRODUCTION

SITE INFORMATION

TIER AND RISK DESIGNATION

BEST PRACTICAL TREATMENT OR CONTROL (BPTC) MEASURES

1. Site Description
 - 1.1. Site Characteristics
 - 1.2. Site Map
 - 1.3. Historic Site Activities
 - 1.4. Local Native Vegetation
2. Erosion Prevention BPTC Measures
 - 2.1. Existing and Proposed Erosion Prevention BPTC Measures
 - 2.1.1. Physical and Biological Erosion Prevention Measures
3. Sediment Control BPTC Measures
 - 3.1 Existing and Proposed Sediment Control BPTC Measures
 - 3.1.1. Physical and Biological Sediment Control Measures
4. Maintenance Activities – Erosion Prevention and Sediment Control
 - 4.1. Erosion Prevention/Sediment Control Monitoring and Maintenance
 - 4.2. Captured Sediment Stabilization/Removal Methods
5. Long Term Stabilization Measures
 - 5.1. Revegetation Activities
6. Compliance with General Order Schedule Limits
 - 6.1. Compliance Schedule and Scope of Work

APPENDICIES

Appendix A: Site Map

Appendix B: Disturbed Area Map

Appendix C: BPTC Implementation and Maintenance Schedule

Appendix D: BPTC Measure Specifications

Appendix E: References

Appendix F: Water Use Records

Appendix G: Fertilizer, Pesticide, Herbicide, and Rodenticide Product List and Records

Appendix H: Monthly BPTC Monitoring and Maintenance Records

Appendix I: Monthly PH and Turbidity Monitoring Records (Moderate and High Risk)

INTRODUCTION

This Disturbed Area Stabilization Plan (Plan) has been developed to satisfy conditions of the High Risk enrollment requirements in the State Water Resource Control Board (SWRCB) Order No. WQ 2017-0023-DWQ (Order), and Order No. 2015-0023 for the North Coast Regional Water Quality Control Board (NCRWQCB).

The Disturbed Area Plan will describe how the best practical treatment and control (BPTC) measures described in the Site Management Plan will be implemented to achieve the goal of stabilizing the disturbed area to minimize the discharge of sediment off-site, and complying with the setback requirements.

High Risk classification is a temporary condition that exists until the Discharger stabilizes the disturbed area located within the setbacks. Once the area is stabilized and the RWB approves the work, the Discharger can petition the RWB to reclassify the site as either low or moderate risk, depending upon the site conditions.

SITE INFORMATION

Registrant: Lost Coast Lady Farms, LLC
998 11th Street
Arcata, CA 95521

Site Address: 33856 Mattole Road
Petrolia, CA 95558

Parcel: Assessor Parcel Number: 105-131-005 & 105-131-006
Lat/Long: 40.2805°, -124.2502°

Zoning: General Plan: Agriculture
Zone: Agriculture Exclusive (AE)

Acres: Approximately 3.30 (APN: 005) and 0.74 (APN: 006) acres (Humboldt County WebGIS)
Disturbed Area: Approximately. 0.28 acres

Location: The project site is in the Petrolia area, approximately 50 miles south of Eureka. To reach the site from Eureka, take US-101 south for 15 miles to exit 692 toward Ferndale/Fernbridge. Continue on Fernbridge Dr. for .5 miles. Turn right onto CA-211 S for 4.1 miles. Right for 0.3 miles on Arlington Ave and left onto 5th street for 0.6 miles. Right on Ocean Avenue for 115 feet and then left onto Wildcat Ave for 0.2 miles. Right onto

Mattole Rd for approximately 30 miles. Project Driveway will be on you right.

Site Description: The project is located in the Mattole Watershed on 4.3 acres. The site is at an elevation of 200 feet with a class II watercourse flowing east to west just to the north of the property line. The Mattole river is approximately 350 feet from the site. The property is relatively flat with slopes at approximately 15%. The surrounding parcels are timber to the west and agricultural fields east before the Mattole River.

TIER AND RISK DESIGNATION

The Cannabis Policy provides criteria for evaluating threats to water quality for cannabis cultivation sites based on three site characteristics: proximity to water body, total disturbed area, and slope of the disturbed area. Based on the criteria and site characteristics the subject property is designated as a **Tier 1 Discharger**. The total disturbed area is 11,120 ft², which is equal to 0.26 acres (Table 1).

Table 1: Disturbed Area Size, Slopes, and Setbacks

| Disturbed Area Type | Area (ft ²) | Disturbed Area Slope | Distance to Water Body (ft.) | Water Body Type |
|-----------------------------|-------------------------|----------------------|------------------------------|----------------------|
| Cultivation Area 1 | 2,500 | 8% | 35 | Class II Watercourse |
| Cultivation Area 2 | 3,000 | 9% | 140 | Class II Watercourse |
| Cultivation Area 3 | 2,750 | 7% | 370 | Class II Watercourse |
| Drying Shed | 240 | 8% | 50 | Class II Watercourse |
| Conex Box | 400 | 8% | 60 | Class II Watercourse |
| Residence | 1,125 | 8% | 70 | Class II Watercourse |
| Accessory Residence | 240 | 6% | 310 | Class II Watercourse |
| Shed #2 | 384 | 6% | 330 | Class II Watercourse |
| Shed #3 | 131 | 5% | 400 | Class II Watercourse |
| Shed #4 | 131 | 5% | 400 | Class II Watercourse |
| Spent Soil | 144 | 5% | 400 | Class II Watercourse |
| Water tank 2.5k | 25 | 10% | 10 | Class II Watercourse |
| Water tank 1.5k | 25 | 8% | 40 | Class II Watercourse |
| Water tank 2.5k | 25 | 8% | 140 | Class II Watercourse |
| Total Disturbed Area | 11,120 | | | |

The main entrance road is located off Mattole Road. Mattole Road is a paved and striped county maintain road. The 300 feet of driveway was originally established for the site residence in 2004 before cannabis activity. Thus, the area of the road network is not included in the total disturbed area. See the disturbed area map in Appendix B for specific areas included in the disturbed area.

In addition, a risk designation is assigned based on the slope of the disturbed areas and proximity to a waterbody. Based on these parameters, the subject property is designated as a **High Risk**. 5,390 square feet of the total disturbed area is located within 100 feet of a class II watercourse, which is a violation to the riparian setback requirements. There are no disturbed areas located on sloped greater than 30 percent.

BEST PRACTICAL TREATMENT OR CONTROL (BPTC) MEASURES

BPTC measures are being utilized as part of the road maintenance program to protect water quality. The *Solid Waste Management, Construction Site Best Management Practices Manual* by the CA Department of Transportation (Caltrans) is referenced for the correct installation, maintenance, and monitoring of all applicable erosion control and sediment capture BPTC measures.

All straw mulch must be free of noxious weeds and all seed/plants must be non-invasive. A list of prohibited species can be found in the CA Invasive Plant Council's database. Erosion control measures shall not include synthetic monofilament netting, including photo- and biodegradable plastic netting. All netting shall be made of jute, coir fiber, hemp, or another product without welded weaves.

A schedule of BPTC measures to be implemented and maintained throughout the site is shown in Appendix C, and Appendix D includes specifications for BPTCs.

1. Site Description

1.1. SITE CHARACTERISTICS

The project is located in the Mattole Watershed on 4.3 acres. The site is at an elevation of 200 feet with a class II watercourse flowing east to west just to the north of the property line. The project site is located on soils consisting of Johnnyjack and Sproulish-Canocreek-Redwohly complex (USDA WebSoilSurvey). Both soils are in Hydrological Soil Group C, and both are considered to be well drained. The Mattole river is approximately 350 feet from the site. The project site contains grasses and trees that are native to the area. The immediate topography is relatively flat with slopes of approximately 15%. The surrounding parcels are timber to the west and agricultural fields to the east, before the Mattole River. The project location receives approximately 80.2 inches of rain per year, with majority of precipitation occurring in winter months (PRISM).

1.2. SITE MAP

The Site Map in Appendix A shows locations of waterbodies, disturbed areas within stream setbacks, and the location where storm water sampling will take place.

1.3. HISTORICAL SITE ACTIVITIES

After investigating historical aerial photographs from Google Earth, it is evident that land disturbance started in 2004.

The 300 feet of driveway was originally established for the site residence in 2004 before cannabis activity.

1.4. LOCAL NATIVE VEGETATION

Table 1 below contains plant species that are native to the area where the project is located (CNDDDB Quad Species List). The table lists the vegetation type, names, as well as Federal and State endangered/threatened/rare status. Other local vegetation includes conifers forests and oak woodlands.

Table 1: CNDDDB Quad Species List.

| Element Type | Scientific Name | Common Name | Federal Status | State Status | Taxonomic Sort |
|-------------------|------------------------------|----------------------------|----------------|--------------|--|
| Plants - Lichens | Usnea longissima | Methuselah's beard lichen | None | None | Plants - Lichens - Parmeliaceae - Usnea longissima |
| Plants - Vascular | Lathyrus glandulosus | sticky pea | None | None | Plants - Vascular - Fabaceae - Lathyrus glandulosus |
| Plants - Vascular | Erythronium revolutum | Coast fawn lily | None | None | Plants - Vascular - Liliaceae - Erythronium revolutum |
| Plants - Vascular | Montia howellii | Howell's montia | None | None | Plants - Vascular - Montiaceae - Montia howellii |
| Plants - Vascular | Epilobium septentrionale | Humboldt County fuchsia | None | None | Plants - Vascular - Onagraceae - Epilobium septentrionale |
| Plants - Vascular | Piperia candida | white-flowered rein orchid | None | None | Plants - Vascular - Orchidaceae - Piperia candida |
| Plants - Vascular | Calamagrostis foliosa | leafy reed grass | None | Rare | Plants - Vascular - Poaceae - Calamagrostis foliosa |
| Plants - Vascular | Gilia capitata ssp. pacifica | Pacific gilia | None | None | Plants - Vascular - Polemoniaceae - Gilia capitata ssp. pacifica |

2. EROSION PREVENTION BPTC MEASURES

2.1. EXISTING AND PROPOSED EROSION PREVENTION BPTC MEASURES

A rolling dip will be installed at the RD-1 on the Site Map. The rolling dip will discourage concentrated flow down the road towards a class II watercourse. The rolling dip will be implemented during the dry summer months. RD-1 will be constructed to not disrupt the normal traveling speed of traffic. See Appendix C for the schedule of all BPTC implementation and maintenance.

Bare surfaces of all roads will be rocked to prevent further surface erosion and sediment mobilization

All exposed soil in disturbed areas will be seeded and mulched with straw and existing live mulch will be maintained. Any areas for planned disturbance/development will be surveyed for sensitive habitat or species.

2.1.1. PHYSICAL AND BIOLOGICAL EROSION PREVENTION BPTC MEASURES

The rolling dip will be outsloped toward the agricultural field at approximately 3 to 5 percent and rocked. The axis of the rolling dip is to be perpendicular to the road alignment. The road surface will be rocked and a top dressing will be applied to prolong road surface and minimize soil mobilization.

Bare surfaces of all roads will be rocked to prevent further surface erosion and sediment mobilization. The rock used to cover the road should be durable enough to withstand pressures, and it is to be well graded with a compact, blocky shape. The compact, blocky shape will allow for good compaction and help immobilize the rock. (PWA Roads Manual)

All exposed soil in disturbed areas will be seeded and mulched with straw and existing live mulch will be maintained.

3. SEDIMENT CONTROL BPTC MEASURES

3.1. EXISTING AND PROPOSED SEDIMENT CONTROL BPTC MEASURES

Used soils are stacked, piled and left in plastic backs and stored behind Shed #2, shown on the Site Map in Appendix A. Stored soils will need to be covered with tarps and surrounded by fiber rolls for additional sediment capture.

Cultivation waste is stored between Sheds #3 and #4, shown on the Site Map in Appendix A. Cultivation waste piles will need to be covered with tarps and surrounded by fiber rolls for additional sediment capture.

See Appendix C for the schedule of all BPTC implementation and maintenance.

- 3.1.1 **PHYSICAL AND BIOLOGICAL SEDIMENT CONTROL BPTC MEASURES**
Stored soils and cultivation waste piles will need to be covered by tarps and surrounded by fiber rolls. The tarp is to be draped over the stored soil and cultivation waste piles, covering all soil and waste completely. Fiber rolls are to be placed at the base of the stored soil and piles, surrounding all soil or waste, creating a barrier at the base of the soil/waste pile.

4. MAINTENANCE ACTIVITIES – EROSION PREVENTION AND SEDIMENT CONTROL

4.1. EROSION PREVENTION/SEDIMENT CONTROL MONITORING AND MAINTANANCE

All long-term and interim erosion prevention and sediment capture BPTC measures that have been implemented will be monitored for effectiveness on a monthly basis at a minimum. The rolling dip will be visually monitored to ensure the disconnect of the site's road and the class II watercourse. Cultivation waste and stored soil piles will be visually inspected to ensure the BPTC measures are adequately controlling sediment mobilization. Any vegetation planted on previously disturbed areas will be monitored for success and replanted if necessary.

- 4.2. **CAPTURED SEDIMENT STABILIZATION/REMOVAL METHODS**
Any captured sediment in inboard ditches/drainageways, culvert outfalls, rolling dips, or against silt fences/straw wattles/fiber rolls will be removed and stabilized on a designated flat area. The sediment may be used for site improvement where it will not threaten water quality.

5. LONG TERM STABILIZATION MEASURES

5.1. REVEGETATION ACTIVITIES

All exposed soil shall be reseeded/revegetated and have 2-4" of weed-free mulch applied. Any vegetation planted on previously disturbed areas will be monitored for success and replanted if necessary. Exotic or invasive species found in revegetated or disturbed areas shall be removed.

6. COMPLIANCE WITH GENERAL ORDER SCHEDULE LIMITS

6.1. COMPLIANCE SCHEDULE AND SCOPE OF WORK

If the Discharge will not be able to achieve compliance by the onset of the next winter period (e.g., stabilization work will continue into the winter period or will continue the following year), the Discharger shall include a compliance schedule and scope of work for approval by the Regional Water Quality Control Board Executive Officer and for use in preparing an enforcement order.

Appendix A: Site Map

LOST COAST LADY WATER RESOURCE PROTECTION PLAN & SITE MANAGEMENT PLAN

APN: 105-131-005 & 105-131-006

SITE DESCRIPTION:

THE PROJECT IS LOCATED IN THE MATTOLE WATERSHED ON 4.3 ACRES. THE SITE IS AT AN ELEVATION OF 200 FEET WITH A SLOPE OF 15% TO THE MATTOLE RIVER. THE MATTOLE RIVER IS APPROXIMATELY 350 FEET FROM THE SITE. THE PROPERTY IS RELATIVELY FLAT WITH SLOPES AT LESS THAN 15%. THE RELATIVELY FLAT AREAS ARE SLOPING DOWN TO THE WEST AND AGRICULTURAL FIELDS EAST BEFORE THE MATTOLE RIVER.

THE PROJECT IS ENROLLED IN THE NROWGS ORDER NO. 2015-0023, WQID #181719SCHUM AS A TIER 2 DISCHARGER.

SHEET INDEX:

00 - PLOT PLAN & PROJECT NOTES

PLOT PLAN

2024 SHEET 1-60

11X17 SHEET 11-80

0 20 40 60

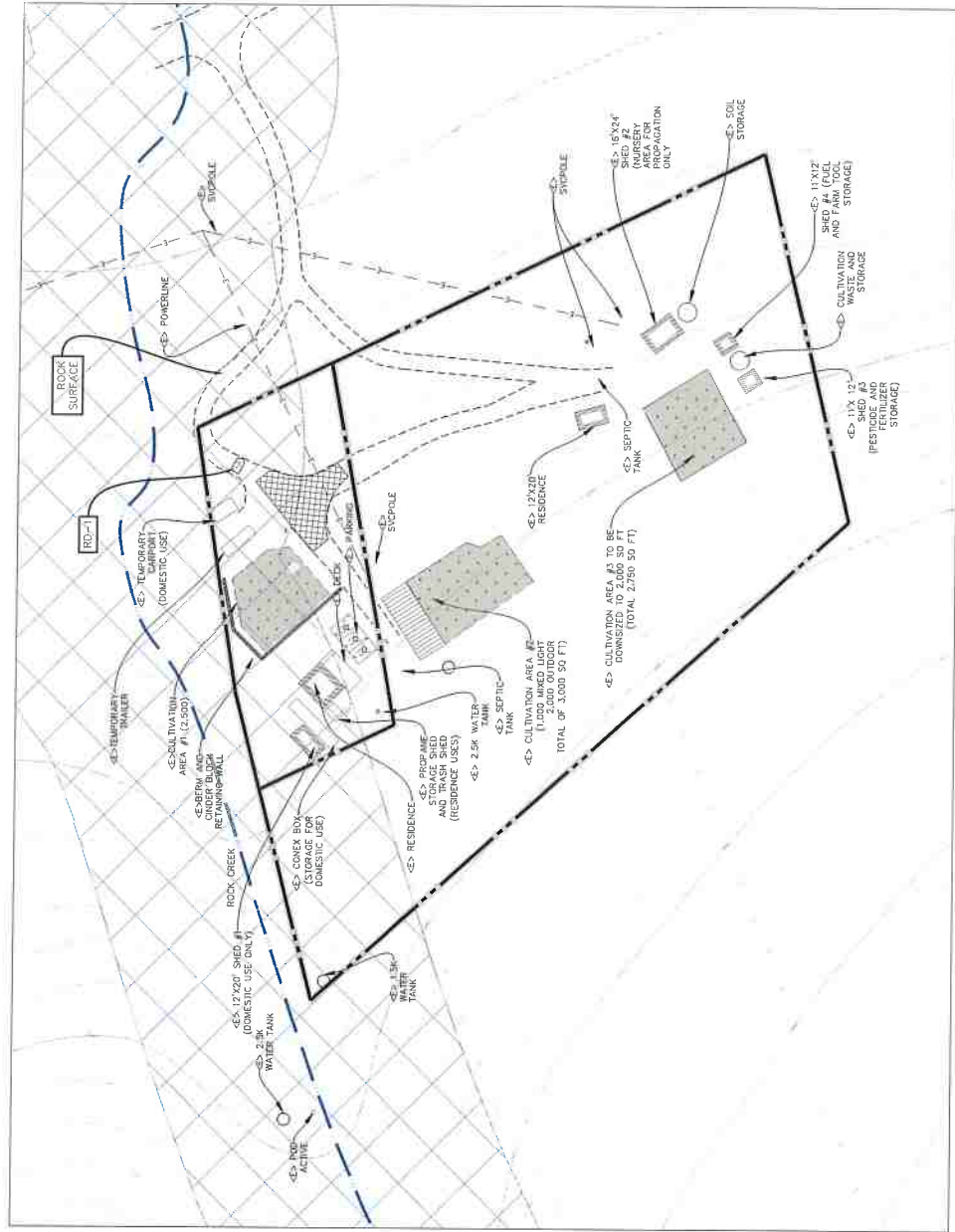

Appendix B: Disturbed Area Map

Disturbed Area Map
105-131-005 and 105-0131-006
Total Disturbed Area= 0.26 acres



Legend

-  Cultivation Areas
-  Structures and Water Tanks



400 ft

Appendix C: BPTC Implementation and Maintenance Schedule

CULTIVATION ACTIVITIES SCHEDULE

Highlight or check off the months when the following activities will take place.

BPTC IMPLEMENTATION & MAINTENANCE SCHEDULE

| Type | | Measures | | | | | | | | | | | |
|---|----------------------|--|-----|-----|-----|-----|-----|-----|-----|-----|-----|-----|-----|
| | | Jan | Feb | Mar | Apr | May | Jun | Jul | Aug | Sep | Oct | Nov | Dec |
| EROSION PREVENTION | Runoff Management | Diversions - Perimeter Dikes, Swale, Check Dams, Water Bars, Rolling Dips Lined Waterway, Grade Stabilization Structures | | | | | | | | | | | |
| | Soil Stabilization | Non-Vegetative Soil Cover - Mulching, Soil Tackifiers, Slope Protection, Riprap, Fiber Rolls and other Rolled Erosion Control Products (RECP), Plastic Cover, Surface Roughening | | | | | | | | | | | |
| | Structural | Retaining Wall, Sediment Basins/Traps, Silt Fences; Armoring and Velocity Dissipators; Inlet, Outlet, and Streambank Protection/Stabilization | | | | | | | | | | | |
| | Runoff Management | Diversion/Conveyance - Grassed Waterway | | | | | | | | | | | |
| SEDIMENT CONTROL | Soil Stabilization | Temporary/Permanent Seeding, Hydroseeding, Topsoiling, Live Mulching, Vegetation Preservation/Replacement | | | | | | | | | | | |
| | Biotechnical | Biotechnical - Wattling, Brush Layering, Branch Packing, Live Cribwalls, Live Fascines, Live Plantings, Vegetated Streambank Protection, Vegetated Gabions | | | | | | | | | | | |
| | Runoff Management | Sediment Conveyance - Lined Drainageways | | | | | | | | | | | |
| | Sediment Retention | Sediment Basins/Traps - Pipe Outlet Traps, Embankment and Debris Basins, Settling Ponds, Rock Dams | | | | | | | | | | | |
| SEDIMENT CONTROL | Sediment Barriers | Straw Bale Dikes, Drain Inlet Filters, Gravel Bag Berms, Fiber Rolls, Silt Fences, Turbidity Curtain | | | | | | | | | | | |
| | Mud and Dust Control | Construction Entrance and Road Stabilization, Dust Control, Waterway Crossing | | | | | | | | | | | |
| | Soil Stabilization | Hydroseeding, Vegetated Outfalls | | | | | | | | | | | |
| INTERIM EROSION & SEDIMENT CONTROL MEASURES | | Installed and Maintained as Needed | | | | | | | | | | | |

Appendix D: BPTC Measure Specification

Table of Contents

| |
|--|
| RD1.1 Modified Low Water Rock Ford |
| RD1.2 Fords |
| RD1.3 Outsloped Roads w/ Inboard Swale |
| RD1.4 Outsloped Road |
| RD1.5 Inslope Road |
| RD1.6 Thru Cut Road |
| RD1.7 Critical Dips |
| RD1.8 Rolling Dip |
| RD1.9 Grading Unpaved Road Surfaces |
| RD1.10 Water Bars |
| RD1.11 Ditch Relief Culverts (DRC) |
| RD1.12 Stream Crossing Installation |
| RD1.13 Drainage for Unpaved Roads |
| RD1.14 Road Surface Upgrade |
| RD1.15 Routing and Location |
| RD1.16 Understanding Road Removal |
| RD1.17 Road Closure |
| EC1.1 Jute Mat Blanket |
| EC1.2 Culvert Outlet Energy Dissipater |
| EC1.3 Outlet Protection |
| EC1.4 Stockpile Management |
| SS-6 Straw and Mulch |
| SS-7 Geotextiles, Mats, Plastic Covers, and Erosion Control Blankets |
| SS-10 Outlet Protection |
| SS-11 Slope Drains |
| SC1.1 Check Dams |
| SC1.2 Sediment Basin |
| SC1.3 Fiber Rolls |
| Road BMP Resources |



RD-1.1 MODIFIED LOW WATER ROCK FORD

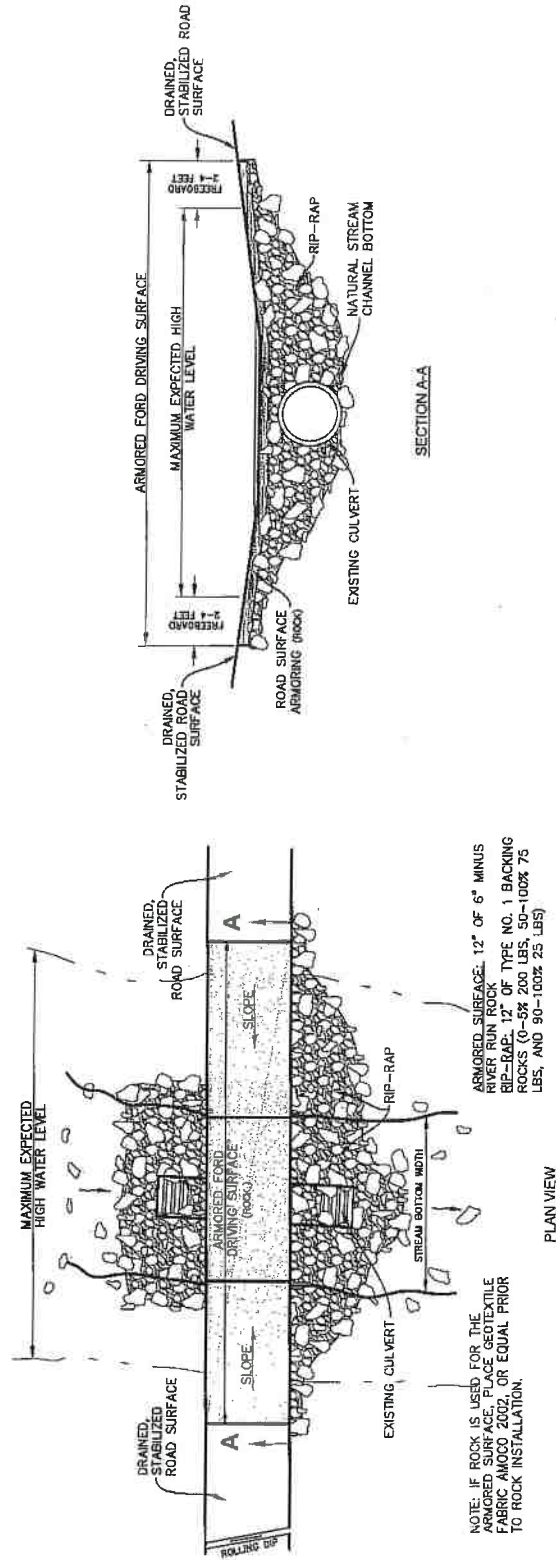

RD-1.2 FORDS

DESCRIPTION

Fords work well on small to medium sized streams where there is a stable stream bottom and traffic is light. However, "construction" of fords and other unimproved stream crossings on well traveled roads should be avoided where water is flowing because of their potential to impact water quality. In certain situations, where flash floods, high seasonal flood peaks or floating debris are problems, fords may be a practical answer for crossing a poorly incised, shallow stream.

BEST MANAGEMENT PRACTICES

- Fords in flowing streams, called "wet fords," are typically composed of streambed gravels, fill, or concrete structures built in contact with the streambed so that vehicles can cross the channel (Figure 1).
- Fords should be designed to allow low summer flows seep through the fill, and high water discharges flow over the top (Figure 2).
- Paving fords across flowing streams may be necessary to maintain water quality if there is to be regular traffic. Paving consists of a concrete, slightly dish-shaped slab across the watercourse, and a discharge apron or energy dissipater on the downstream side to prevent scour during high flows.
- On small, poorly incised, ephemeral or intermittent streams a ford may be needed if there is insufficient channel depth to install a culvert. In fact, a rock lined rolling dip with a rock apron face is generally desirable to permanent culverts on these swales and small watercourses. Fords have the advantage, over culverted fills, of never plugging.
- Fords on small streams should be rock armored to prevent erosion of the road surface and fill during periods of runoff. The fill face on the downstream side of the fill can either be protected with rock armor or fitted with a large overside drain (berm drain) to prevent erosion (Figure 3).
- Unimproved fords, which consist of a stream channel that has been filled with a substantial quantity of soil and left unprotected by armor or surfacing is a hazard to water quality and should not be constructed.

Figure 1. Wet ford on Class II perennial stream. Clean rock aggregate has been imported for the travelling surface and coarse rock armor protects the outer edge of the road bed. It is important that rock aggregate used in a ford be large enough to resist transport during winter flows. Fords should not be used if high winter flows would cut off access to inspect and maintain drainage structures further out the road. From Weaver and Hagans (1994).

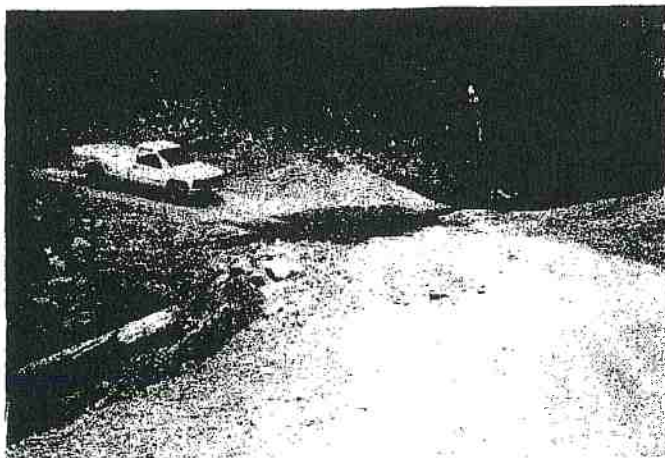

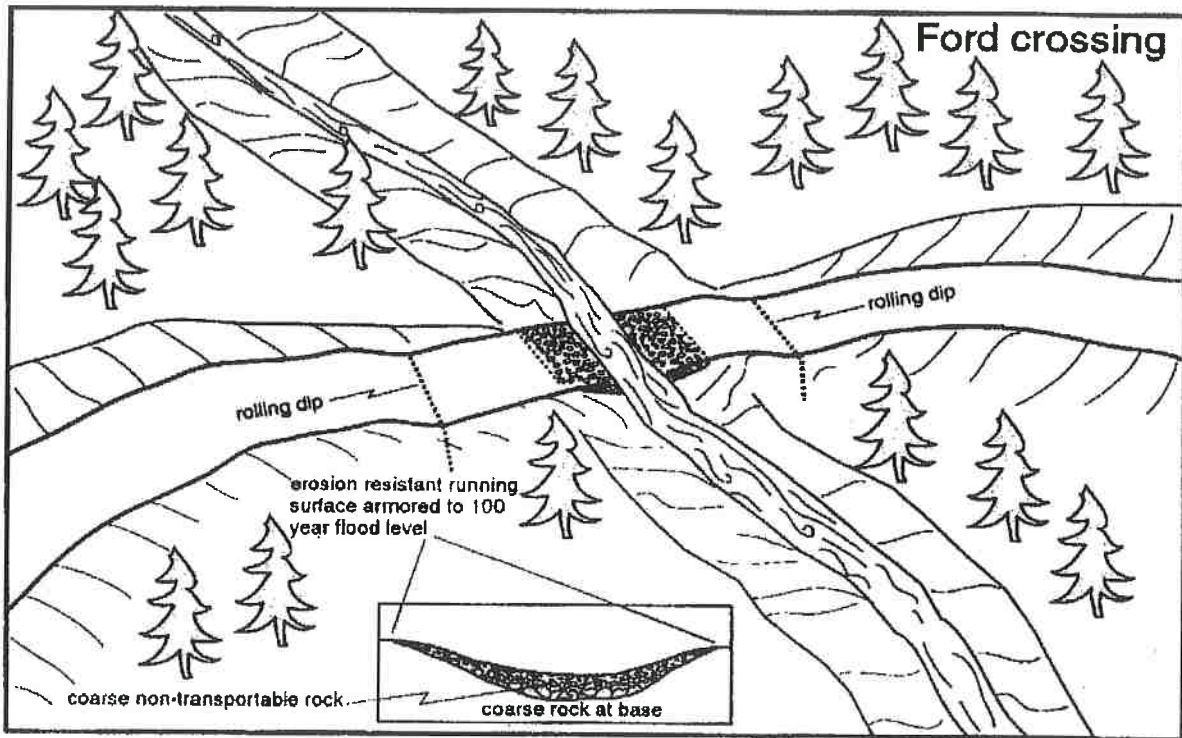

Figure 2. Typical ford stream crossing. From CDFG (2006).

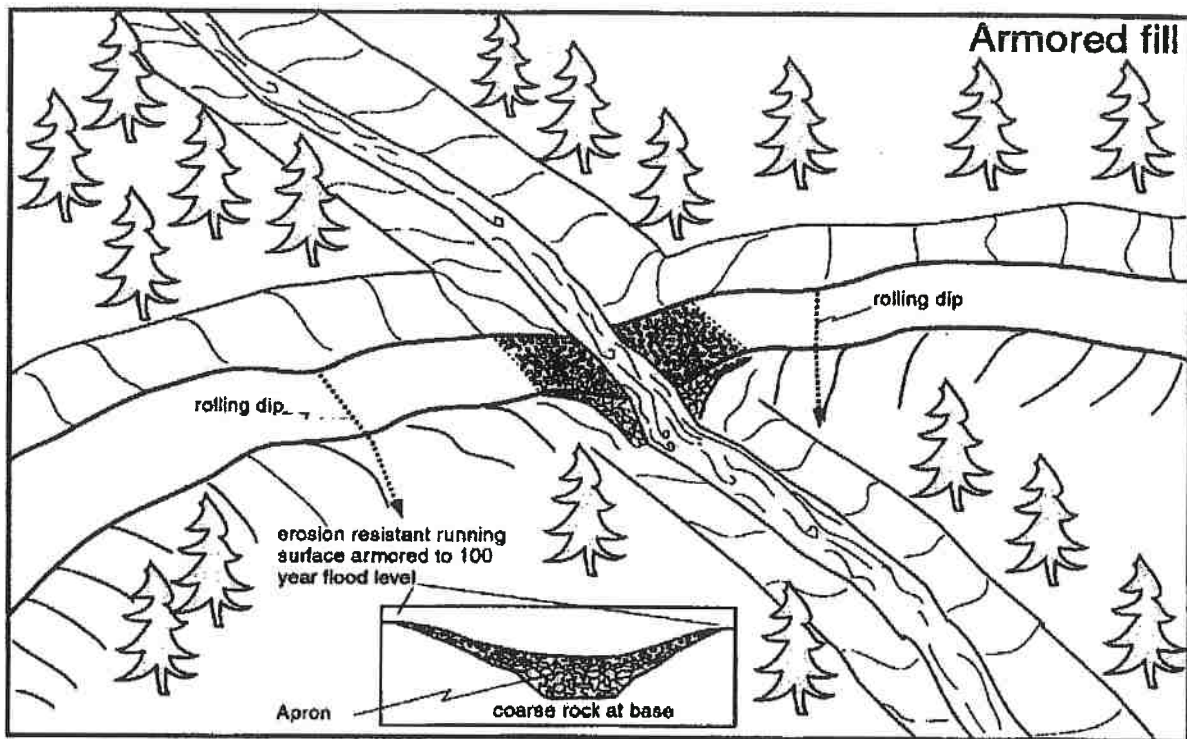

Figure 3. Typical armored stream crossing. From CDFG (2006).

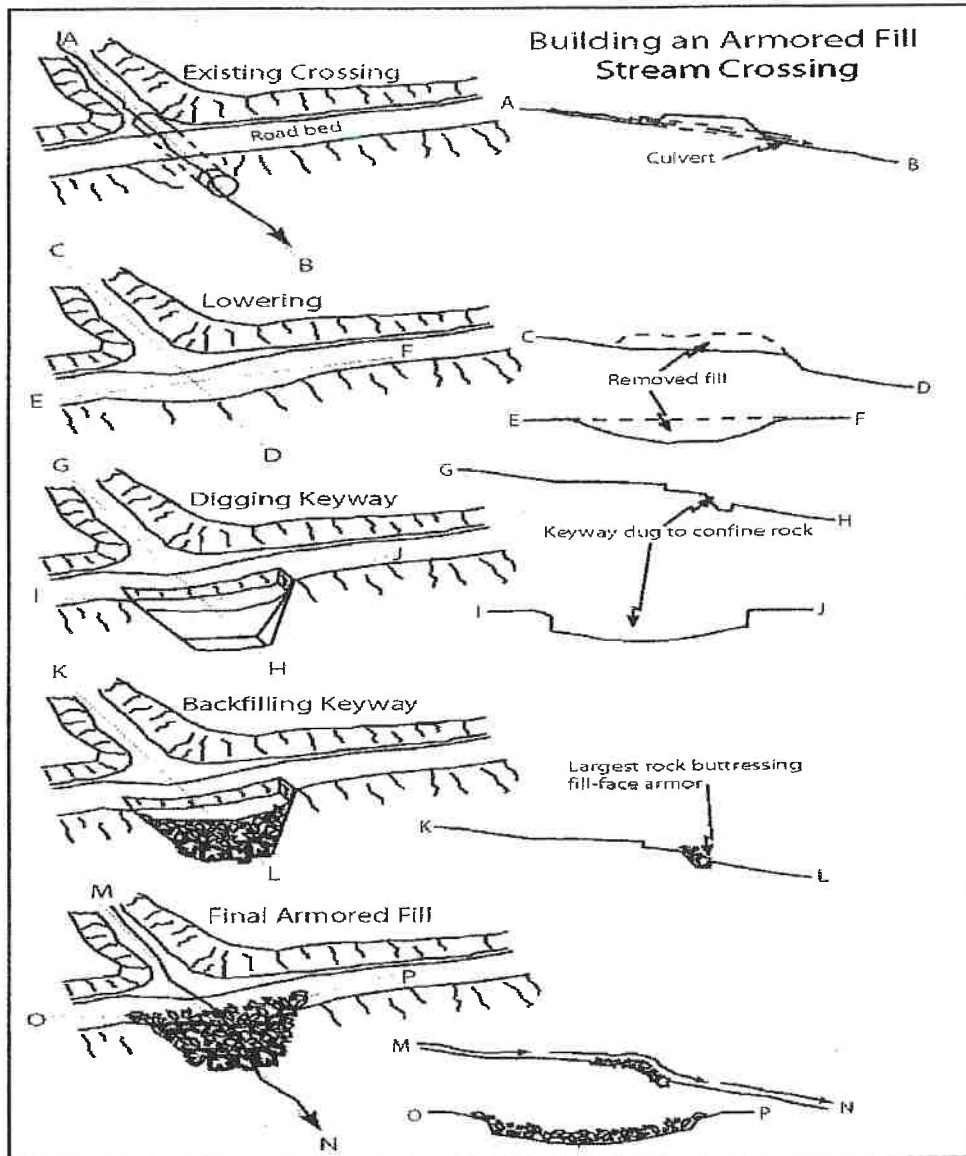

Figure 4. Design elements of a typical armored fill crossing. Note: where geotextile fabric may interfere with passage of amphibians in any Class 2 or 3 crossing, bury geotextile fabric with at least 6 inches of rock. Do not expose geotextile fabric in the bed of fish-bearing stream channels. From CDFG (2206).

Source Material for Road BMP RD-2.7 Fords

2006. California Department of Fish and Game. Part X - Upslope Erosion Inventory and Sediment Control Guidance, California Salmonid Stream Habitat Restoration Manual.

1994. Weaver W.E. and D.K. Hagans. Handbook for Forest and Ranch Roads. Mendocino County Resource Conservation District

RD-1.3 OUTSLOPED ROAD W/ INBOARD SWALE

NOTE: ALL ROAD WIDTHS TO BE 12' MINIMUM AND ROCKED/REINFORCED WITH 2" MINIMUM AGG. BASE FROM ON SITE SOURCE

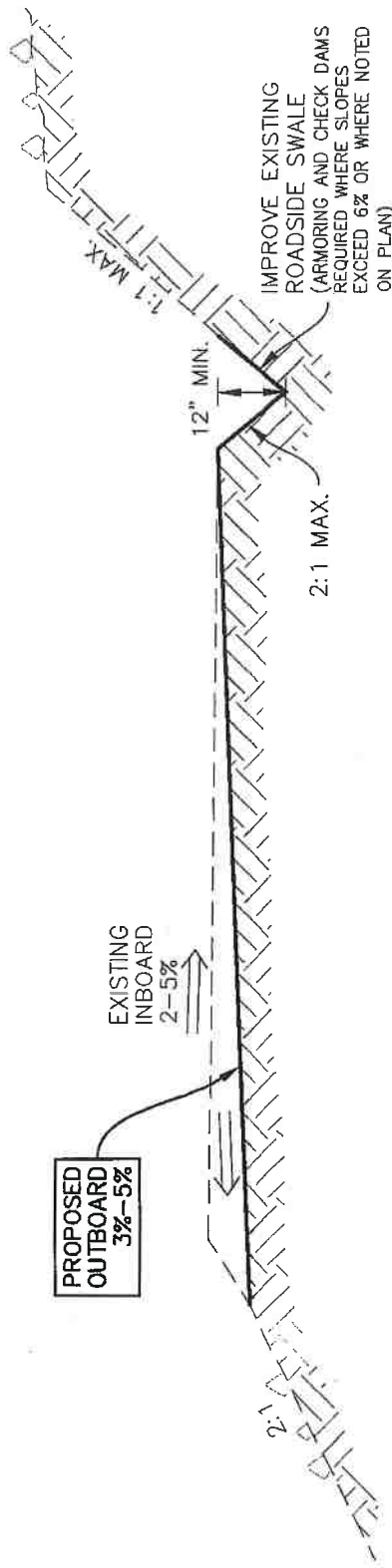

OUTSLOPE ROAD W/ INBOARD SWALE

RD-1.4 OUTSLOPED ROAD

NOTE: ALL ROAD WIDTHS TO BE 12' MINIMUM AND ROCKED/REINFORCED WITH 2" MINIMUM AGG. BASE FROM ON SITE SOURCE

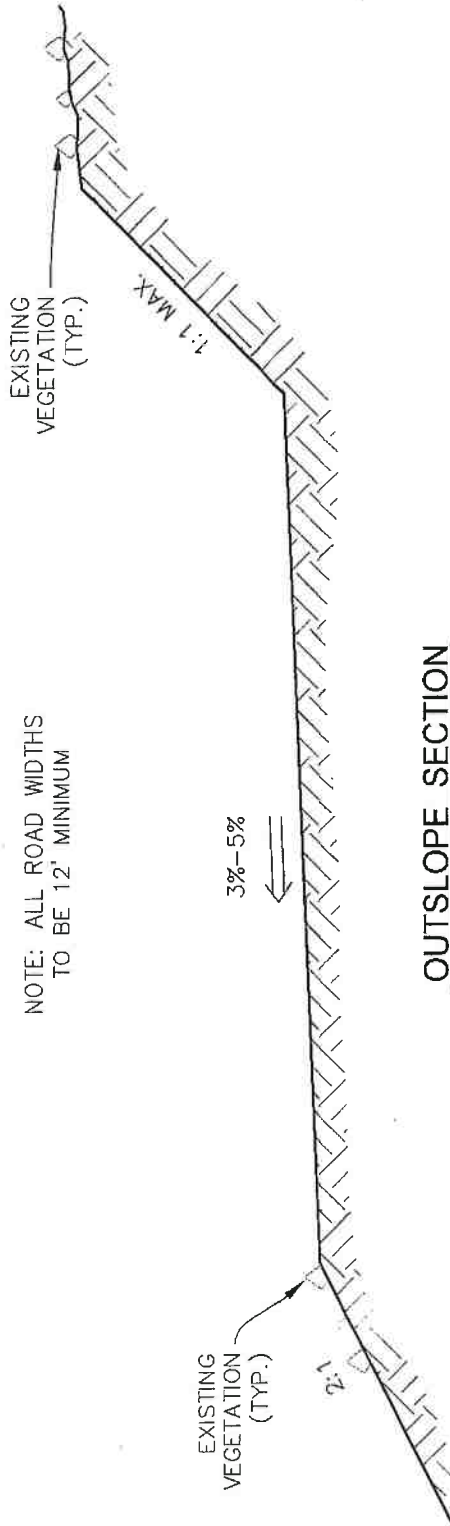

NOTE: ALL ROAD WIDTHS TO BE 12' MINIMUM

OUTSLOPE SECTION

RD-1.5 INSLOPE ROAD

NOTE: ALL ROAD WIDTHS TO BE 12' MINIMUM AND ROCKED/REINFORCED WITH 2" MINIMUM AGG. BASE FROM ON SITE SOURCE

NOTE: ALL ROAD WIDTHS TO BE 12' MINIMUM

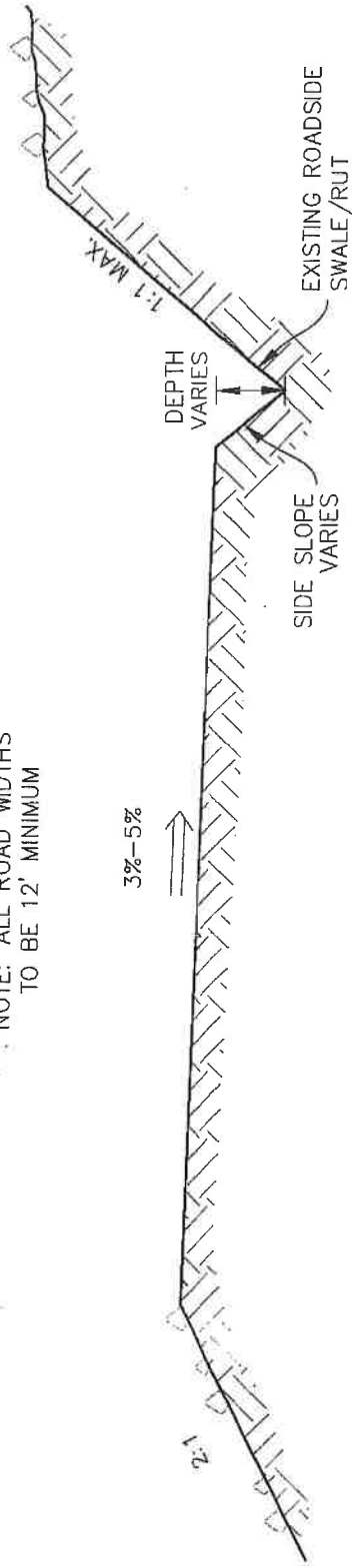

INSLOPE SECTION

RD-1.6 THRU CUT ROAD

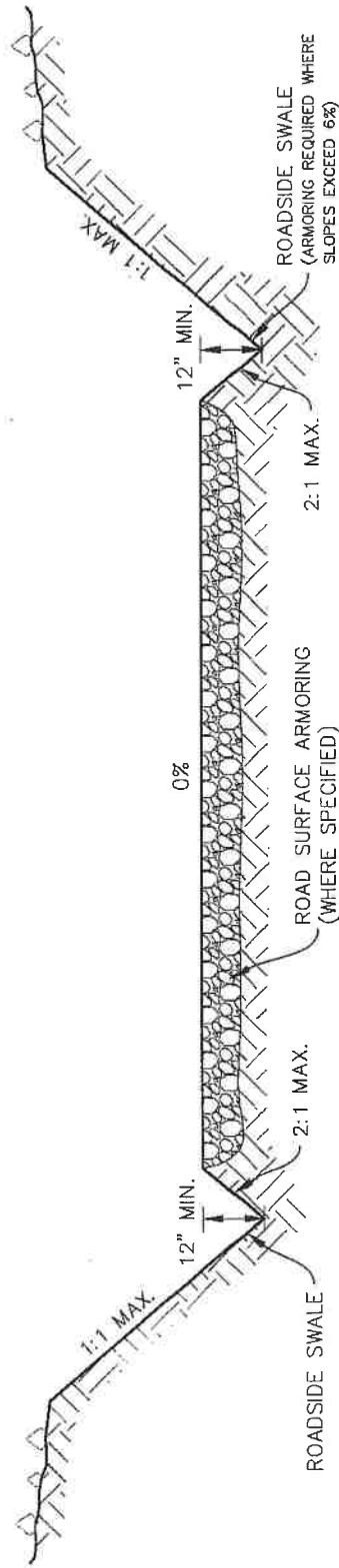

NOTE: IF ROCK IS USED FOR THE ARMORED SURFACE, PLACE GEOTEXTILE FABRIC AMOCO 2002, OR EQUAL PRIOR TO ROCK INSTALLATION.

ARMORED SURFACE: 12" OF CLASS 2 AGGREGATE BASE (3" MINUS, WELL GRADED AND LESS THAN 5% CLAYS)

RD-1.7 CRITICAL DIPS

DESCRIPTION

A critical dip is a rolling dip constructed on or close to the down-road hinge-line of a stream crossing, displaying a diversion potential. Build a critical dip at all stream crossings in order to prevent stream diversions when a culvert plugs and water flows out onto the road. Construction may be similar to Road BMP RD-1.8 Rolling Dips.

BEST MANAGEMENT PRACTICES

- Stream crossings should be constructed to prevent diversion of flood overflow if the culvert were to become plugged. This can be done by designing the road to dip into and out of the stream at the crossing site or by installing a broad rolling dip on the down-road side of the crossing. This will allow the overflow to be directed back into the natural stream channel (Figure 1).
- Critical dips should be designed to handle the 100-year flow event for the stream it is installed at.
- Road surface and fill slopes at the critical dip should be rocked or otherwise stabilized.
- Must be deep enough that it is not obliterated by normal grading, but not so deep that it is difficult to negotiate or a hazard to normal traffic (Table 1).
- See Road BMP RD-1.8 Rolling Dips for more details.

| Road grade % | Upslope approach (distance from up-road start of rolling dip to trough) (ft) | Reverse grade (distance from trough to crest) (ft) | Depth below average road grade at discharge end of trough (ft) | Depth below average road grade at upslope end of trough (ft) |
|--------------|--|--|--|--|
| <6 | 55 | 15-20 | 0.9 | 0.3 |
| 8 | 65 | 15-20 | 1.0 | 0.2 |
| 10 | 75 | 15-20 | 1.1 | .01 |
| 12 | 85 | 20-25 | 1.2 | .01 |
| >12 | 100 | 20-25 | 1.3 | .01 |

Table 1. Table of rolling dips dimensions. Design principles apply to critical dip. From CDFG (2006).

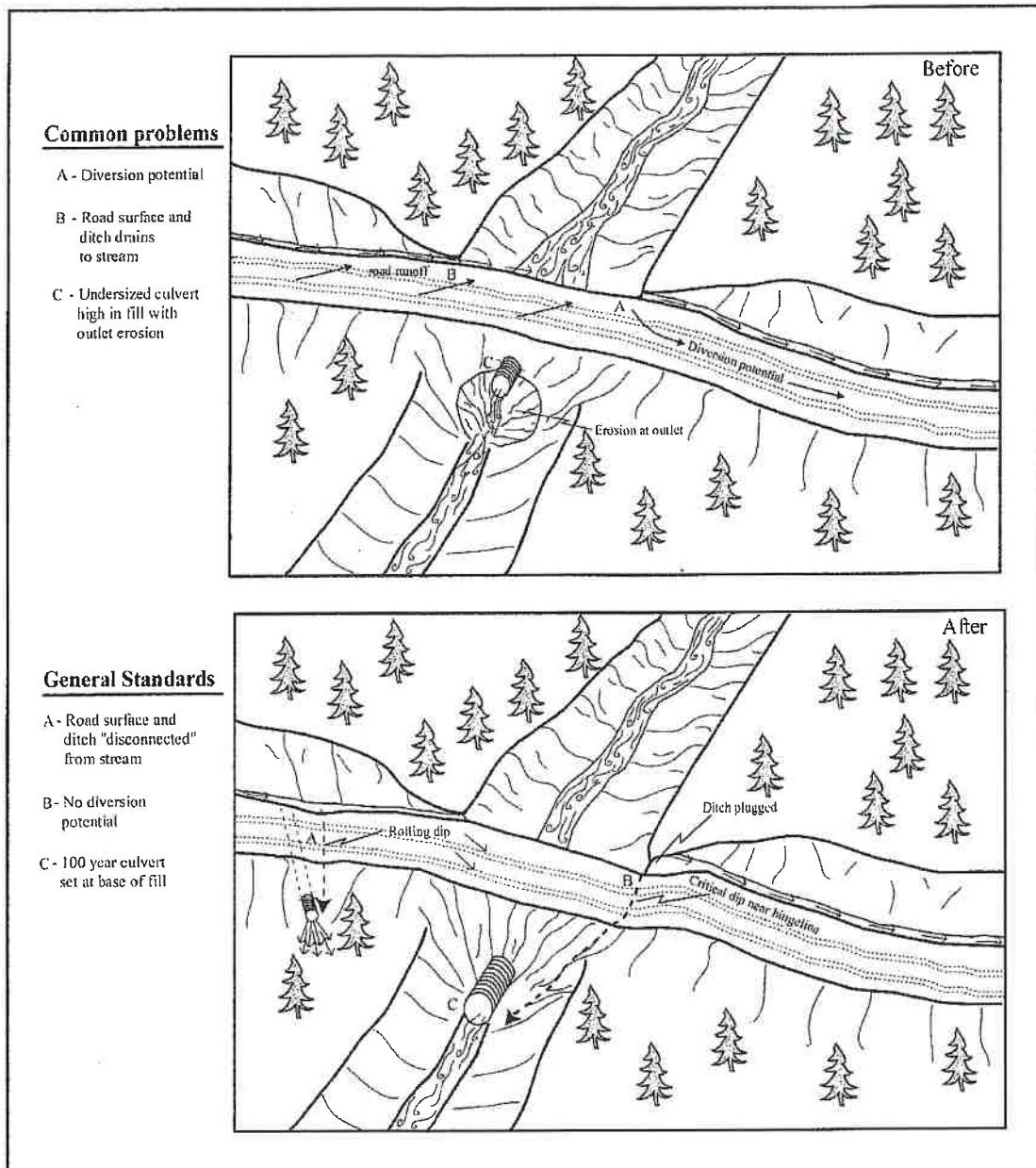

Figure 1. Install critical dips to prevent diversion prevention at stream crossings. Critical dips should be designed to handle the flow from a 100-year storm event. From CDFG (2006).

Source Material for Road BMP 2.9 Critical Dips

2006. California Department of Fish and Game. Part X - Upslope Erosion Inventory and Sediment Control Guidance, California Salmonid Stream Habitat Restoration Manual.

2004. FishNet 4C. Guidelines for Protecting Aquatic Habitat and Salmon Fisheries for County Road Maintenance.

RD-1.8 ROLLING DIP

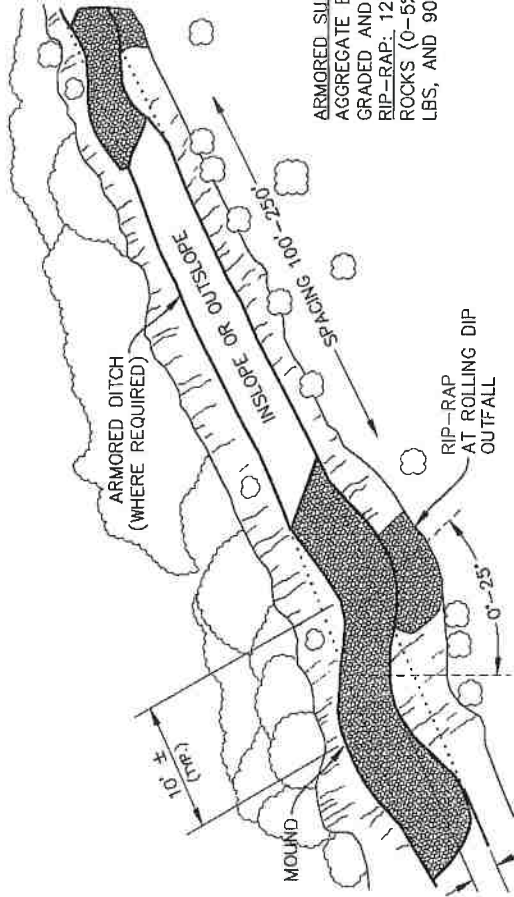

ARMORED SURFACE: 12" OF CLASS 2
 AGGREGATE BASE (3" MINUS, WELL
 GRADED AND LESS THAN 5% CLAYS)
 RIP-RAP: 12" OF TYPE NO. 1 BACKING
 ROCKS (0-5% 200 LBS, 50-100% 75
 LBS, AND 90-100% 25 LBS)

NOTE: PORTIONS ARE
 EXAGGERATED FOR
 CLARITY

ROLLING DIP DETAIL

NOT TO SCALE

TABLE 1: ROLLING DIP AND DITCH
 RELIEF CULVERT RECOMMENDATIONS

| ROAD GRADE (%) | SOIL ERODIBILITY EROSIVE SOILS (FT) |
|----------------|--|
| 0-3 | 250 |
| 4-6 | 160 |
| 7-9 | 130 |
| 10-12 | 115 |
| 12+ | 100 |

RD-1.9 GRADING UNPAVED ROAD SURFACES

DESCRIPTION

Good maintenance practices on unpaved road surfaces prevent roadway erosion, deterioration or failure; helps with sediment and dust control, and provides a safe roadway surface for the traveling public.

BEST MANAGEMENT PRACTICES

- Fit grading to the surrounding terrain.
- Blade and compact a smooth surface and compact loose soils as needed.
- Crown or slope the road to avoid ponding or concentration of runoff. Outslope all roads where possible and safe.
- Preserve existing vegetation to the greatest extent feasible.
- Minimize the length and steepness of slopes.
- Maintain natural drainage patterns in watershed.
- Preserve or improve surface drainage in the vicinity of the road.
- Disconnect road drainage features from watershed hydrology.
- Make sure drainage is self-maintaining.
- Keep runoff velocities low, using energy dissipating control measures.
- Minimize amount of road-related sediment that gets into watercourses.
- Prevent dust abatement chemicals from getting into watercourses or riparian areas.

SEASONAL CONCERNS

- Perform routine road surface maintenance during the dry season. Avoid working in wet conditions and during the wet season (October 15- April 15), except for emergencies. Disturbed soil combined with rainfall, greatly increase the risk of exposed sediment runoff into streams.
- Inspect roads and associated drainage facilities for signs of erosion or deterioration at least twice annually with at least one inspection during or after first storm events of the season with additional follow-up for severe storm events. Inspect all road and drainage facilities after a large storm event. Note locations of road surfaces, drainage features, cutslopes and fillslopes that appear to be failing and contributing sediment to streams in order to prioritize maintenance or repair.

SPOILS AND SIDECASTING

- Avoid sidecasting of soil in all cases where it could be delivered into a watercourse, riparian area, roadside ditch or storm drain. In some instances, under the following guidelines (Table 1), sidecasting is allowable given remote distances from spoils storage sites. In these cases, the setback distance required depends on slope and vegetation. The presence of vegetation helps to slow the travel of sediment downslope, so good judgment is needed to assess the situation. *Do not sidecast at all* if the slope is sparsely vegetated and it appears that sediment will travel with rain runoff into a stream or estuary system, even if setback distances are applied. On slopes of 5:1 (20% gradient) or less, sidecasting is allowed beyond 150 feet of a watercourse, stream crossing, riparian area, roadside ditch or storm drain. On 2:1 slopes (50%) or less, sidecasting is allowed beyond 300 feet of a watercourse, stream crossing, riparian area, roadside ditch or storm drain. On slopes greater than 2:1, typically sidecasting is *not recommended*, however there may be rare instances on slopes greater than 2:1 where sidecasting is acceptable given very long distances from waterbodies and good vegetative cover. Seek advice from local fisheries agency staff when in doubt. Avoid concentrating sidecasting repeatedly in the same place. Never sidecast large amounts of soil from major landslides.

- Temporary spoils stockpiles should be located in areas that are relatively level; relatively free of vegetation and away from streams and wetlands areas (see Erosion Control BMP EC-1.5 Stockpile Management). The primary concern is to keep stockpiled materials from eroding into stream or wetland systems. Apply erosion control BMPs when needed. Do not place temporary spoils piles at the top of unstable slopes or at the edges of slopes where water will carry sediment into watercourses. Remove temporary stockpiles to permanent disposal locations before the rainy season. If emergency work is conducted during the rainy season, remove stockpile as soon as feasible and before the next rain storm.

| SLOPE GRADIENT | DISTANCE FROM WATERCOURSE, STREAM CROSSING, RIPARIAN AREA, ROADSIDE DITCH, STORM DRAIN | SIDECASTING RULE |
|------------------------|---|-----------------------------|
| Any slope | Appears that sediment will travel with rainwater into watercourse. | Not allowed |
| 5:1 (20%) or less | 150 feet or more | Allowed using good judgment |
| 2:1 (50%) or less | 300 feet or more | Allowed using good judgment |
| Greater than 5:1 (50%) | Vegetated slope long distance from watercourse | Allowed |
| Greater than 5:1 (50%) | Sparsely vegetated slope and it appears that sediment will travel with rain into watercourse | Not allowed |

Table 1. Sidecasting guidelines. From: FishNet 4C (2004)

BERMS

- Do not leave loose soil piled in berms alongside the road or ditch. Loose or exposed soil berms are erodible and readily flushed into waterways and storm drains.
- If any berm is left in place for public safety reasons it must be compacted and stabilized with seeding or asphalt. Frequent well placed breaks in the berms are necessary to allow water to drain from road, preserving the natural drainage pattern of the slope.

Source Material for Road BMP RD-3.2 Grading

2004. FishNet 4C. Guidelines for Protecting Aquatic Habitat and Salmon Fisheries for County Road Maintenance.

2002. Five Counties Salmon Conservation Program. A Water Quality and Stream Habitat Protection Manual for County Road Maintenance.

RD-1.10 WATERBARS

DESCRIPTION

Waterbars are shallow, abrupt excavated dips or troughs with an adjacent, downslope hump or mounded berm, that are built at an oblique angle across the road (Figure 1 and 2). Waterbars are useful only on low standard seasonal or temporary, unsurfaced roads where winter use will not occur, because traffic easily cuts through the soft berm and fills the adjacent dip. Waterbars should be constructed at proper spacing according to the grade of the road (Table 3). Waterbars are usually regraded (smoothed out) at the beginning of each operating season, and then reconstructed at the beginning of each winter period.

Waterbars are high maintenance drainage structures that are prone to failure if not properly built and maintained. Unauthorized winter traffic is likely to break down waterbars and result in serious road surface erosion and water pollution.

BEST MANAGEMENT PRACTICES

- Waterbars and rolling dips should be spaced along the road close enough together that the road surface is not gullied (Table 3). Appropriate spacing of surface drainage structures depends on soil credibility and runoff rates. Look at local roads to determine the maximum spacing that will work in your specific area.

| Erosion Hazard Rating (for surface erosion) | Road or Trail Gradient (%) | | | |
|--|----------------------------|--------|--------|----------|
| | 10% or less | 11-25% | 26-50% | over 50% |
| Extremely high | 100' | 75' | 50' | 50' |
| High | 150' | 100' | 75' | 50' |
| Moderate | 200' | 150' | 100' | 75' |
| Low | 300' | 200' | 150' | 100' |

Table 3. From Weaver and Hagans (1994). ¹ Adapted from California Forest Practice Rules. This is the maximum distance between waterbars: when in doubt, reduce the spacing. Soils are nonrenewable and waterbars are inexpensive.

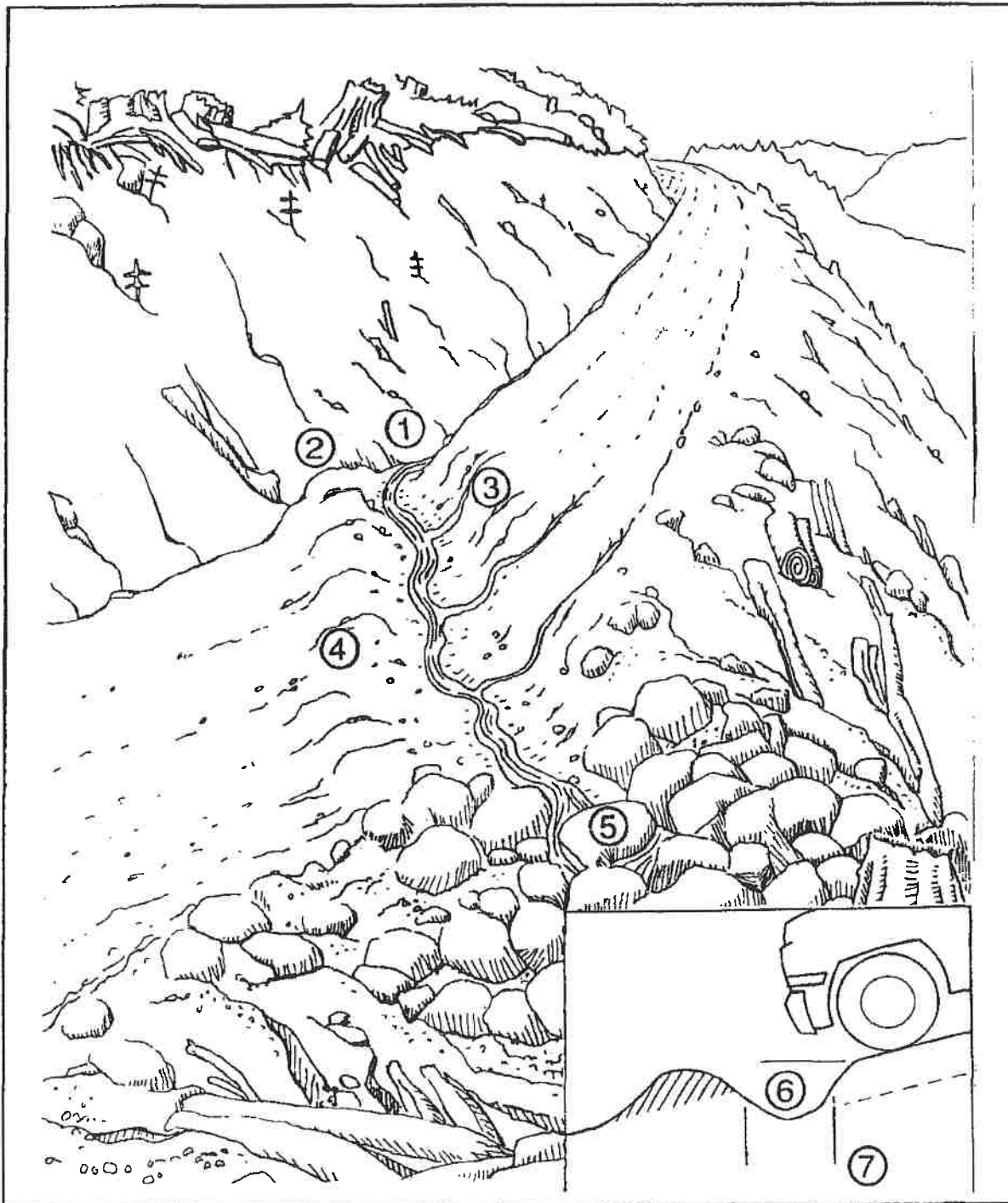

Figure 1. Waterbars are constructed on unsurfaced forest and ranch roads that will have little or no traffic during the wet winter period. The waterbar should be extended to the cutbank to intercept all ditch flow (1) and extend beyond the shoulder of the road. A berm (2) must block and prevent ditch flow from continuing down the road during flood flows. The excavated waterbar (3) should be skewed 30° to the ditch-line with the excavated material bermed on the downhill grade of the road (4). Water should always be discharged onto the downhill side on a stable slope protected by rip rap or vegetation (5). The cross ditch depth (6)

and width (7) must allow vehicle cross-over without destroying the function of the drain (B.C.M.F., 1991). From Weaver and Hagans (1994).

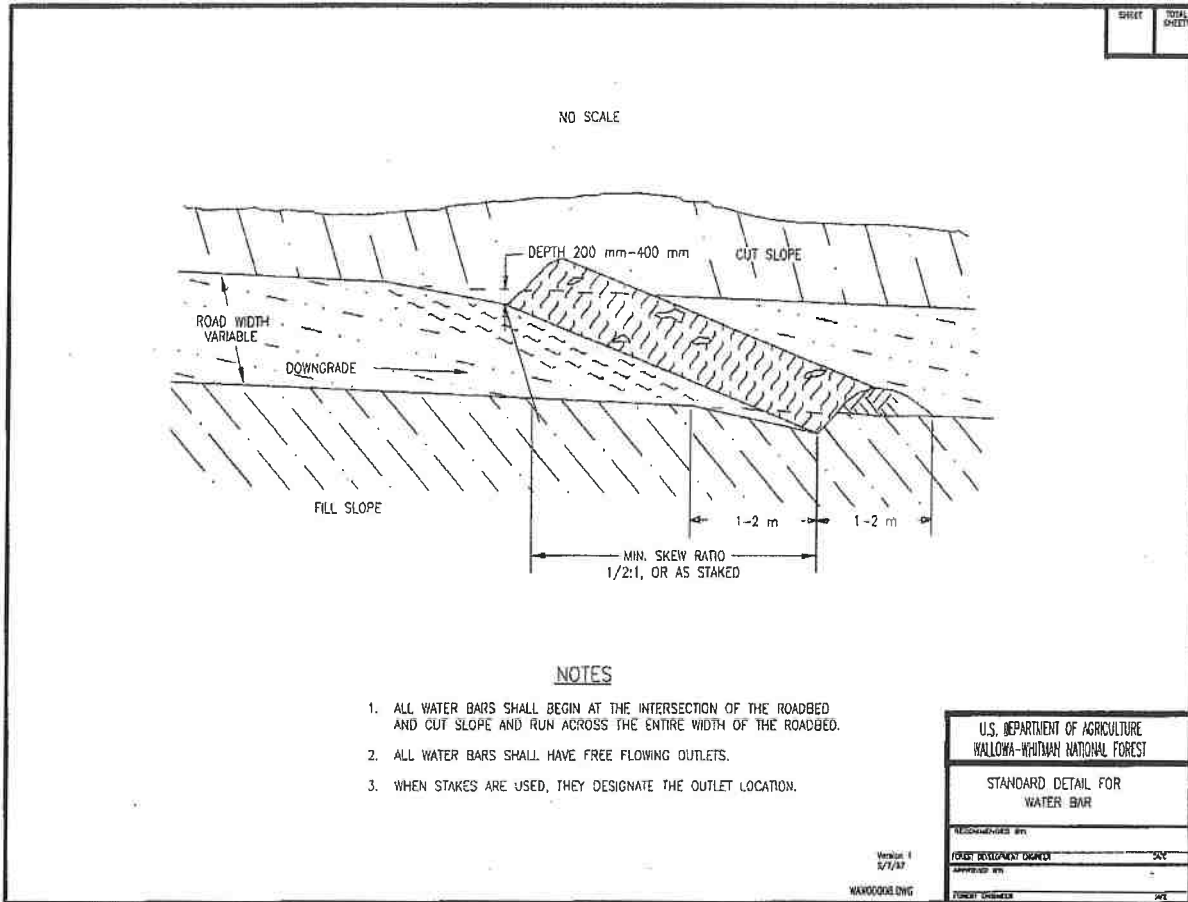

Figure 2. Typical design of a waterbar. From US Forest Service.

Source Material for Road BMP RD-7.8 Waterbars

1994. Weaver W.E. and D.K. Hagans. Handbook for Forest and Ranch Roads. Mendocino County Resource Conservation District

RD-1.11 DITCH RELIEF CULVERT **INSTALLATION**

DESCRIPTION

Ditch relief culverts (DRCs) divert water from an inside road ditch to an outside area beyond the outer edge of the road fill. DRCs take the flow through or beneath the road surface. Ditch relief culverts may also be used to filter water in a buffer zone prior to entering a waterway.

BEST MANAGEMENT PRACTICES

- Culverts should be designed and installed at intervals along the road that are close enough to prevent erosion of the ditch and at the culvert outfall, and at locations where collected water and sediment is not discharged directly into watercourses (Table 1).
- Install ditch relief culverts at an oblique (typically 30 degree) angle to the road so that ditch flow does not have to make a sharp angle turn to enter the pipe (Figure 1). On low gradient roads (<5%), where ditch flow is slow, ditch relief culverts can be installed at right angles to the road.
- Ditches should *neither* be discharged directly into the inlet of a watercourse crossing culvert, nor should ditch relief culverts discharge into a watercourse via surface flow without first directing flow through an adequate filter strip (Figure 2).
- In addition to installing ditch relief culverts on either approach to watercourse crossings, it is also advisable to consider installing ditch drains before curves, above and below through-cut road sections, and before and after steep sections of the road.
- If the ditch is on an insloped or crowned road that is very close to a stream, consider using outsloping to drain the road surface (see Road BMP RD-1.3, 1.4 Outslope Road). The ditch and the ditch relief culvert would then convey only spring flow from the cutbank, and not turbid runoff from the road surface.
- Do not discharge flow from ditch relief culverts onto unstable or highly erodible hillslopes
- Culverts should be installed at the gradient of the original ground slope, so it will emerge on the ground surface beyond the base of the fill. If not, either the fill below the culvert outlet should be armored with rock, or the culvert should be fitted with an anchored downspout to carry erosive flow past the base of the fill (Figure 1).
- Downspouts longer than 20 feet should be secured to the hillslope for stability. Full round downspouts are preferred over half-round downspouts.

Table 1. Maximum suggested spacing for ditch relief culverts¹ (ft)

| Road grade (%) | Soil credibility | | | | |
|----------------|----------------------|----------------------|----------------------|----------------------|----------------------|
| | very high | high | moderate | slight | very low |
| 2 | 600-800 ² | | | | |
| 4 | 530 | 600-800 ² | | | |
| 6 | 355 | 585 | 600-800 ² | | |
| 8 | 265 | 425 | 525 | 600-800 ² | |
| 10 | 160 | 340 | 420 | 555 | |
| 12 | 180 | 285 | 350 | 460 | 600-800 ² |
| 14 | 155 | 245 | 300 | 365 | 560 |
| 16 | 135 | 215 | 270 | 345 | 490 |
| 18 | 118 | 190 | 240 | 310 | 435 |

¹Adapted from Transportation Handbook USDA Forest Service, R-6, 1966. Culvert spacing may be too great in locations where ditch runoff is accumulated and discharged onto steep hillslopes that are prone to gullying. Spacing is designed to control ditch erosion, not culvert outfall erosion, and are based on 25-year storm and precipitation rate of 1-2 in/hr for 15 minutes. If less, multiply by the intensity 0.50, 0.30, etc. If 2-3 in/hr, divide distance in table by 1.50; if 3-4 in/hr, divide by 1.75; and if 4-5 in/hr, divide by 2.00. The U.S. Forest Service also publishes abundant information on preventing and controlling gully erosion below culvert outfalls. From Hagans and Weaver (1994).

²Even with stable ditches, ditch relief culvert spacing greater than about 600 to 800 feet is generally not recommended due to the large volume of road surface and cutslope runoff that would be discharged through the culvert and onto lower slopes during peak runoff periods. Culvert outlet erosion may occur with less than 800 feet of contributing ditch line, so observe local conditions to determine the upper limit of acceptable spacing in your area.

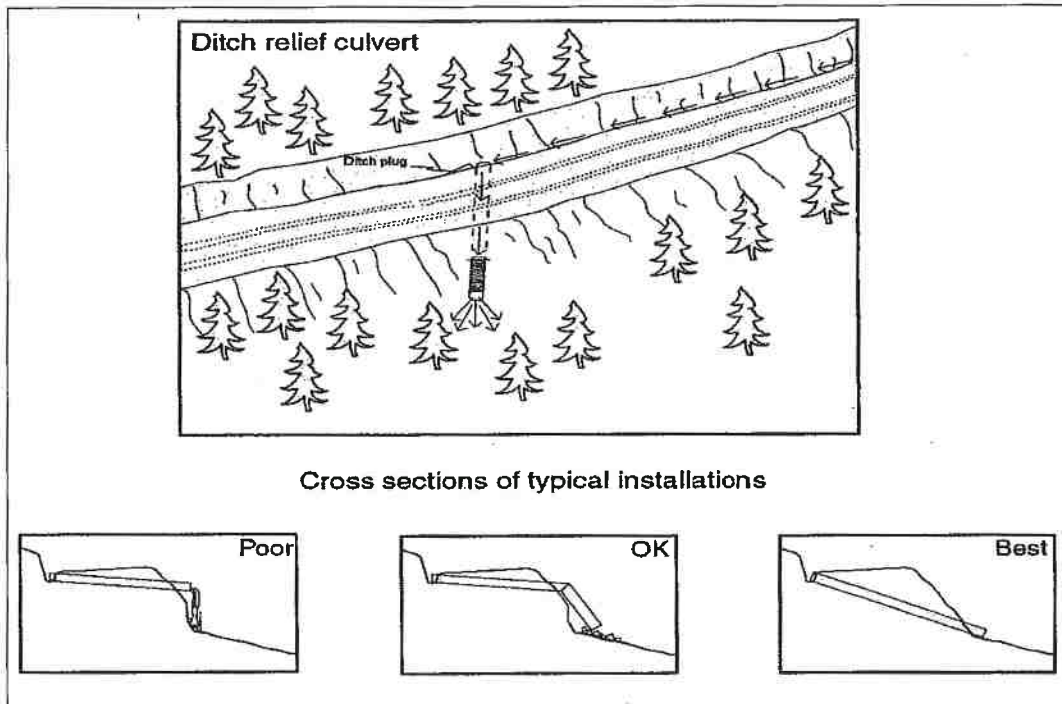

Figure 1. Typical ditch relief culvert installation. (CDFG, 2006)

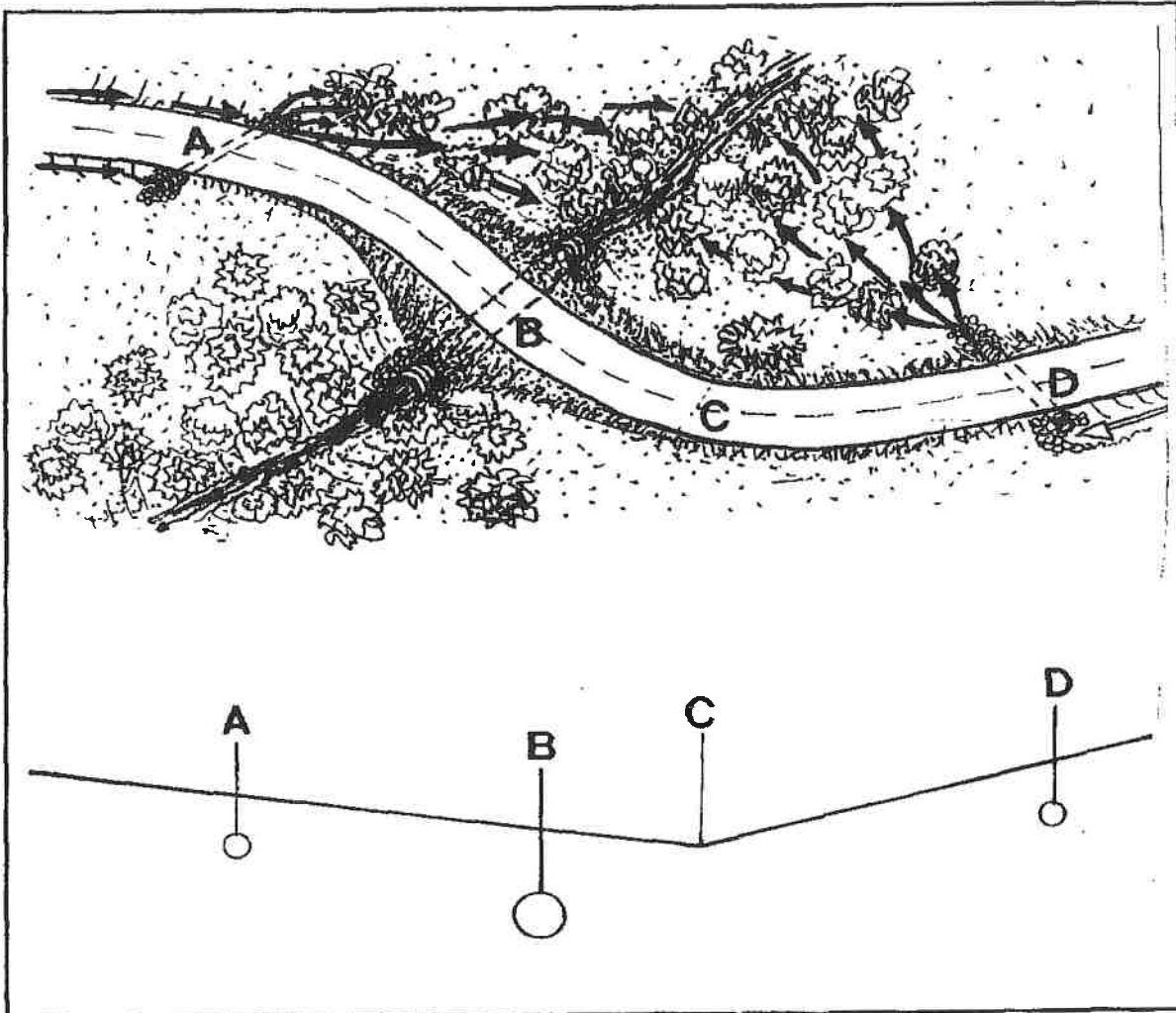

Figure 2. Where a road approaches a stream crossing (B), ditch flow should be culverted across the road (A,D) and discharged into a vegetated buffer that can filter the runoff before it reaches the watercourse. If the stream culvert plugs with debris or is topped by flood flows, flow will spillover the road at the change in grade at location "C" and back into the stream channel (modified from M.D.S.L. 1991). From Weaver and Hagans (1994).

Source Material for Road BMP 2.10 Ditch Relief Culvert Installation

2006. California Department of Fish and Game. Part X - Upslope Erosion Inventory and Sediment Control Guidance, California Salmonid Stream Habitat Restoration Manual.

2004. FishNet 4C. Guidelines for Protecting Aquatic Habitat and Salmon Fisheries for County Road Maintenance.

1994. Weaver W.E. and D.K. Hagans. Handbook for Forest and Ranch Roads. Mendocino County Resource Conservation District

RD-1.12 STREAM CROSSING INSTALLATION

DESCRIPTION

During road building, the construction of culverted stream crossings has the greatest potential of all activities to cause immediate sediment pollution. Culverts should be properly aligned, bedded, backfilled and covered, or they will be subject to eventual failure. In all cases, disturbance to the stream banks and streambed should be minimized during stream crossing construction.

BEST MANAGEMENT PRACTICES

- Culverts should be aligned with the natural stream channel. Correct alignment is critical for the culvert to function properly. Misalignment can result in bank erosion and debris plugging problems (Figure 69a).
- Stream crossing culverts should be placed at the base of the fill, and at the grade of the original streambed (Figure 1) (Figure 69d).
- Culvert should be inset slightly into the natural streambed so that water drops several inches as it enters the pipe. Culvert inlets set too low can plug with debris and those set too high can allow water to undercut the culvert (Figure 69b). Culverts placed midway up the outside of the fill are more likely to plug with sediment or organic debris, because their ability to pass materials is reduced, or to cause erosion of the fill below the culvert outlet (Figure 1).
- The culvert bed may be composed of either compacted rock-free soil, or gravel. If gravel is used for the bed, filter fabric will be needed to separate the gravel from the soil to minimize the potential for soil piping. Bedding beneath the culvert should provide for even distribution of the load over the length of the pipe.
- Inlet and outlet of the culvert should be armored. A metal, concrete, sandbag or rock head-wall can be constructed to prevent inlet erosion. A trash protector can be installed just upstream from the inlet where there is a hazard of floating limbs and wood chunks plugging the culvert inlet. This is especially important on logging roads where the upslope areas have recently been harvested or are slated for harvesting in the future.
- Stream crossings that are not at grade can be retrofitted with a downspout with rock placed at the outlet for armoring against hillslope erosion.

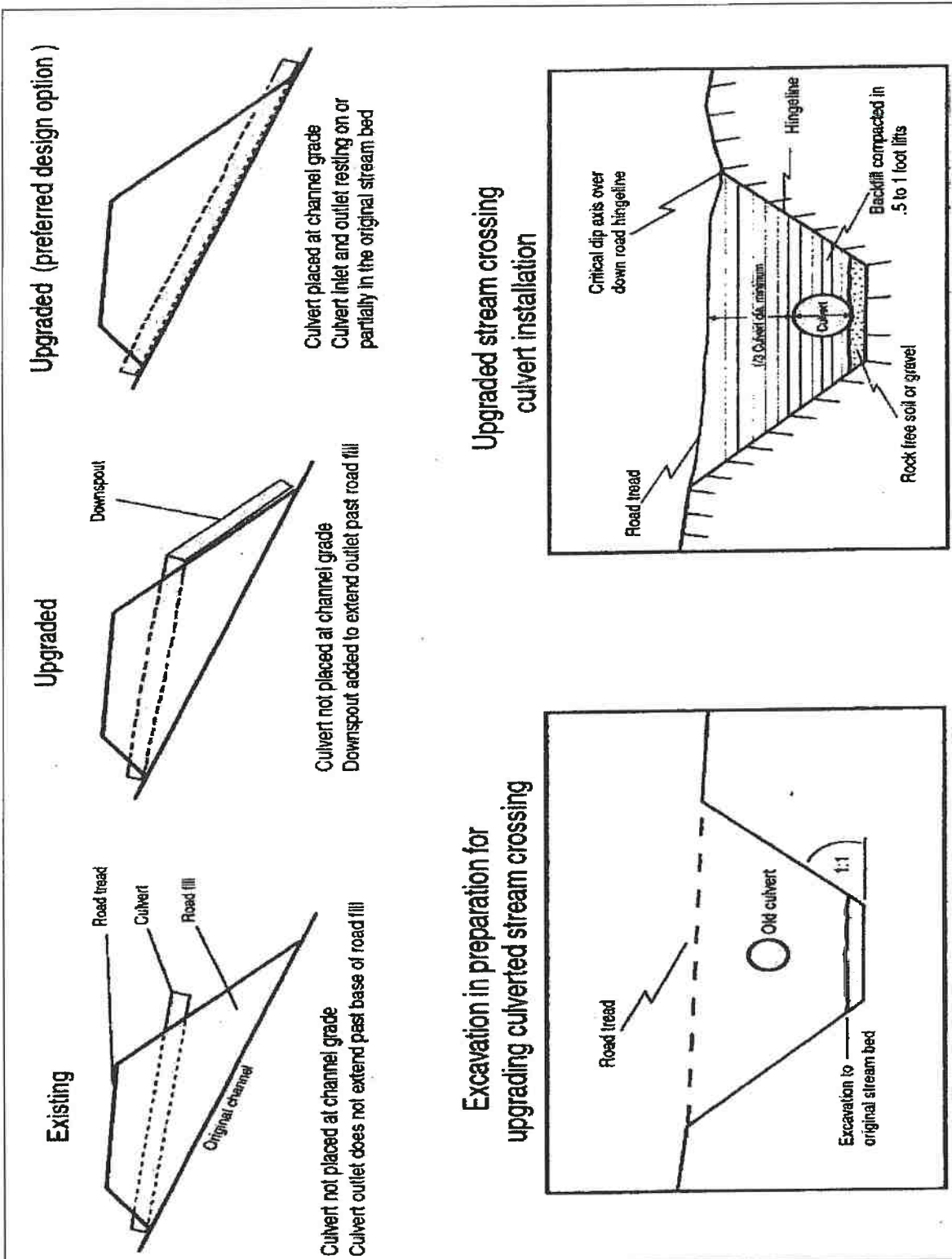

Figure 1. Typical stream crossing installation on non fish-bearing streams. From CDFG (2006).

Figure 69a, b. Proper culvert installation involves correct culvert orientation, setting the pipe slightly below the bed of the original stream, and backfilling and compacting the fill as it is placed over the culvert. Installing the inlet too low in the streambed (A) can lead to culvert plugging, yet if it set too high (B) flow can undercut the inlet (from M.D.S.L., 1991).

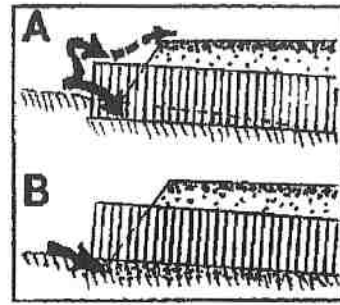

Figure 69c. If the culvert outlet is placed too high in the fill (C), flow at the outfall will erode the fill.

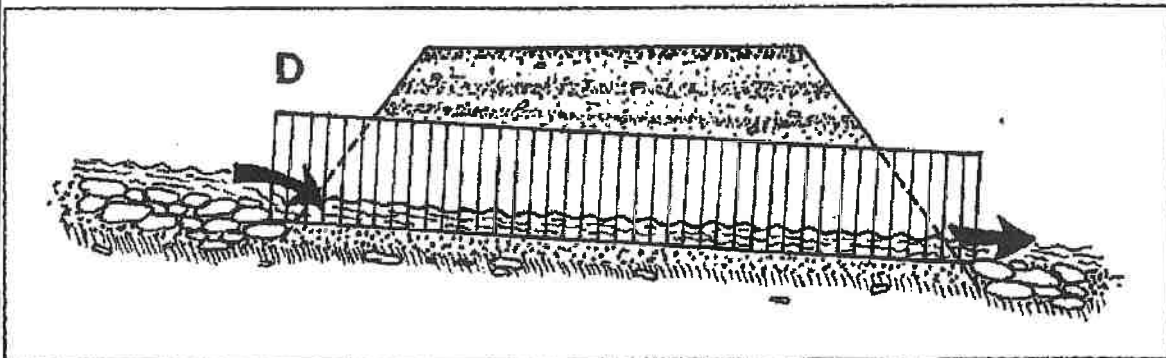
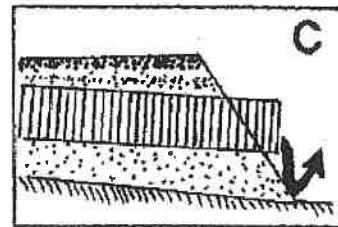

Figure 69d. Placed correctly (D), the culvert is set slightly below the original stream, grade and protected with armor at the inlet and outlet.

Figures 69a,b,c,d. Typical stream crossing installation. From Hagans and Weaver (1994).

Source Material for Road BMP RD-2.8 Stream Crossing Installation

2006. California Department of Fish and Game. Part X - Upslope Erosion Inventory and Sediment Control Guidance, California Salmonid Stream Habitat Restoration Manual.

1994. Weaver W.E. and D.K. Hagans. Handbook for Forest and Ranch Roads. Mendocino County Resource Conservation District

RD-1.13 DRAINAGE FOR UNPAVED ROAD SURFACES

DESCRIPTION

Roads should be designed and constructed to cause minimal disruption of natural drainage patterns. Provisions for two components of road drainage should be included in every road project: 1) road surface drainage (including drainage which *originates* from the cutbank, road surface, and fillslope); and 2) hillslope drainage (including drainage from large springs, gullies, and streams which *cross* the road alignment).

BEST MANAGEMENT PRACTICES

- Maintain natural drainage patterns in watershed through installing drainage features to keep water within sub-basins.
- Crown or slope the road to avoid ponding or concentration of runoff. Outslope all roads where possible and safe (see Road BMP RD-1.3, 1.4 Outslope).
- Use rolling dips instead of ditch relief culverts (DRCs) when possible (Table 1) (Figure 1). Rolling dips require less maintenance and are less prone to failure than culverts (see Road BMP RD-1.8 Rolling Dips).
- Disconnect road drainage features from watershed hydrology. Shorten ditch lengths to stream crossings by installing a ditch relief culvert or rolling dip before the watercourse (see Road BMP RD-1.11 Ditch Relief Culvert Installation).
- In addition to installing DRCs on either approach to the stream crossings, it is also advisable to consider installing ditch drains before curves, above and below through-cut road sections, and before and after steep sections of the road.
- Ditches should neither be discharged directly into the inlet of a stream crossing culvert, nor should DRCs discharge into a watercourse without first directing flow through an adequate filter strip.
- Culverts should be designed and installed at intervals along the road that are close enough to prevent erosion of the ditch and at the culvert outfall. They should be installed at locations where collected water and sediment is not discharged directly into watercourses (Table 2).
- DRCs should not be used on erosive slopes without a downspout (see Construction BMP SS-11 Slope Drain).
- In areas of high erosion and/or storm runoff, *minimum* ditch relief culvert sizes should be 18 inches in diameter, and never less than 12 inches in other areas.
- A 10% grade to the culvert will usually be self cleaning. The culvert grade should also be at least 2% greater than the ditch which feeds it. The culvert should be placed at a 30 degree skew to the ditch to improve inlet efficiency and prevent plugging and erosion at the inlet.

- Stream crossings culverts and DRCs should be installed at the gradient of the original ground slope, so it will emerge on the ground surface beyond the base of the fill. If not, either the fill below the culvert outlet should be armored with rock, or the culvert should be fitted with an anchored downspout to carry erosive flow past the base of the fill (Figure 2) (see Road BMP RD1.12 Stream Crossing Installation).
- Culverts should be covered by a minimum of 1 foot of compacted soil, or a depth of 30% of its diameter, whichever is greater.
- Inlet protection, such as rock armoring or drop structures, can be used to help minimize erosion.
- DRCs must be spaced frequently enough to carry ditch and road surface waters without creating erosive concentrated flows. See attached table for spacing guidelines.

| Road grade % | Upslope approach (distance from up-road start of rolling dip to trough) (ft) | Reverse grade (distance from trough to crest) (ft) | Depth below average road grade at discharge end of trough (ft) | Depth below average road grade at upslope end of trough (ft) |
|--------------|--|--|--|--|
| <6 | 55 | 15-20 | 0.9 | 0.3 |
| 8 | 65 | 15-20 | 1.0 | 0.2 |
| 10 | 75 | 15-20 | 1.1 | .01 |
| 12 | 85 | 20-25 | 1.2 | .01 |
| >12 | 100 | 20-25 | 1.3 | .01 |

Table 1. Table of rolling dips dimensions. From CDFG (2006).

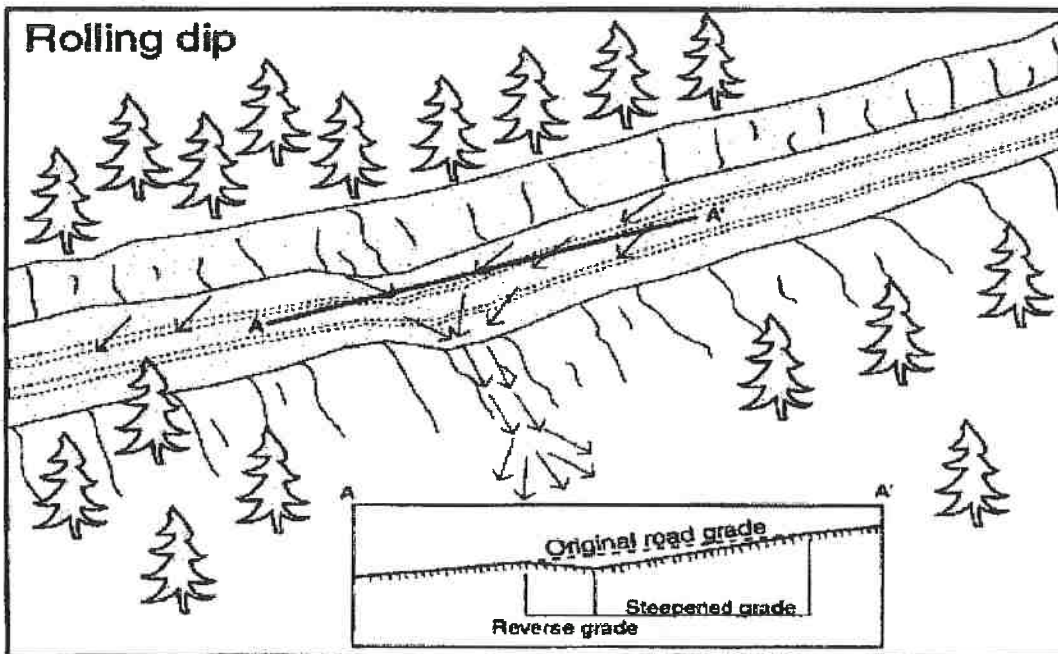

Figure 1. Use of rolling dips to reduce ditch erosion and surface runoff. Rolling dips must drain the road surface and be driveable for the expected traffic. From CDFG (2006).

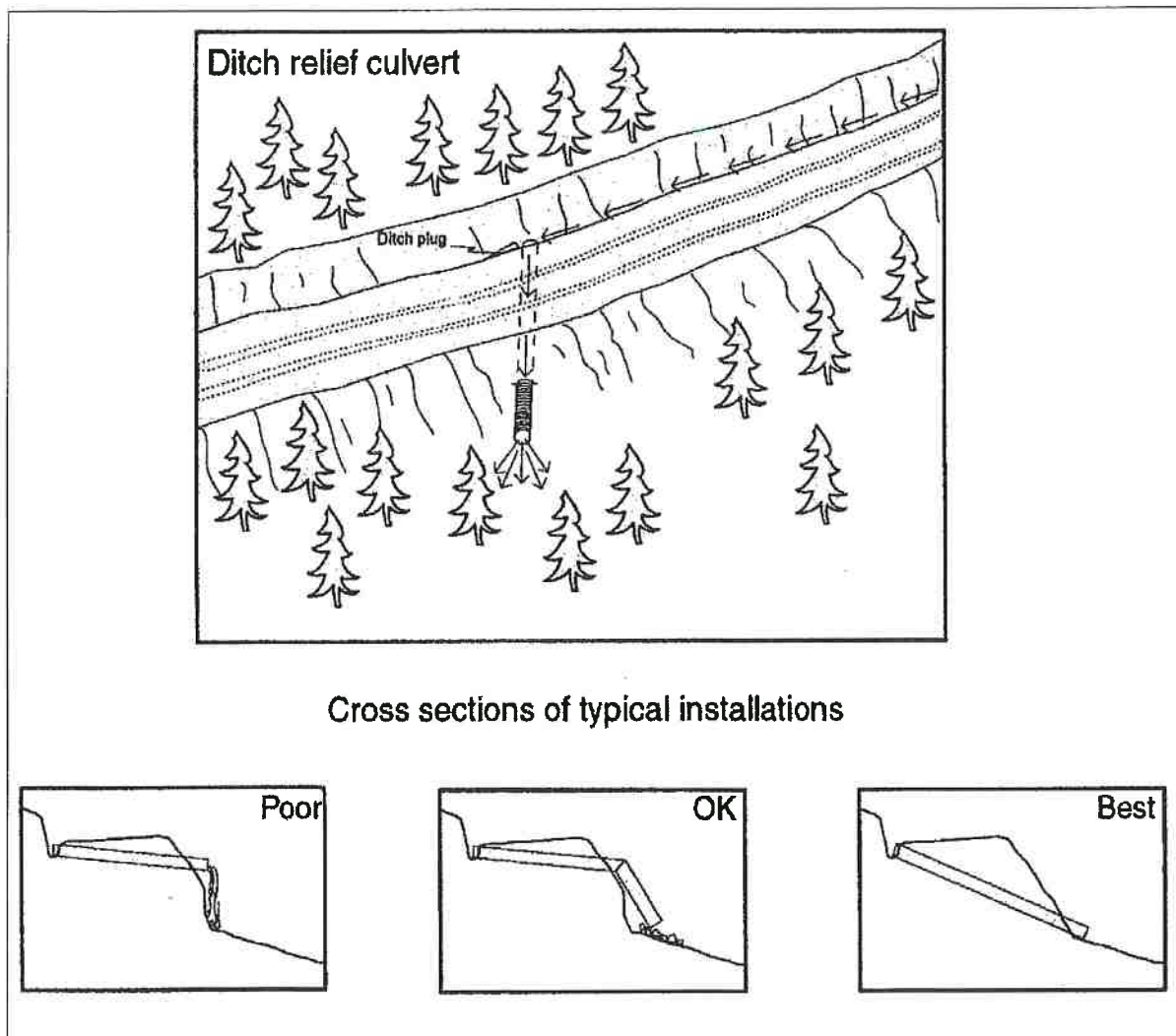

Figure 2. Typical ditch relief culvert installation. From CDFG (2002).

Table 2. Maximum suggested spacing for ditch relief culverts¹ (ft)

| Road grade (%) | Soil credibility | | | | |
|----------------|----------------------|----------------------|----------------------|----------------------|----------------------|
| | very high | high | moderate | slight | very low |
| 2 | 600-800 ² | | | | |
| 4 | 530 | 600-800 ² | | | |
| 6 | 365 | 585 | 600-800 ² | | |
| 8 | 265 | 425 | 525 | 600-800 ² | |
| 10 | 160 | 340 | 420 | 555 | |
| 12 | 180 | 285 | 350 | 460 | 600-800 ² |
| 14 | 155 | 245 | 300 | 365 | 560 |
| 16 | 135 | 215 | 270 | 345 | 490 |
| 18 | 118 | 190 | 240 | 310 | 435 |

¹Adapted from Transportation Handbook USDA Forest Service, R-6, 1966. Culvert spacing may be too great in locations where ditch runoff is accumulated and discharged onto steep hillslopes that are prone to gullying. Spacing is designed to control ditch erosion, not culvert outfall erosion, and are based on 25-year storm and precipitation rate of 1-2 in/hr for 15 minutes. If less, multiply by the intensity 0.50, 0.30, etc. If 2-3 in/hr, divide distance in table by 1.50; if 3-4 in/hr, divide by 1.75; and if 4-5 in/hr, divide by 2.00. The U.S. Forest Service also publishes abundant information on preventing and controlling gully erosion below culvert outfalls. From Hagans and Weaver (1994).

²Even with stable ditches, ditch relief culvert spacing greater than about 600 to 800 feet is generally not recommended due to the large volume of road surface and cutslope runoff that would be discharged through the culvert and onto lower slopes during peak runoff periods. Culvert outlet erosion may occur with less than 800 feet of contributing ditch line, so observe local conditions to determine the upper limit of acceptable spacing in your area.

Source Material for Road BMP RD-1.3 Road Drainage for Unpaved Road Surface

2006. California Department of Fish and Game. Part X - Upslope Erosion Inventory and Sediment Control Guidance, California Salmonid Stream Habitat Restoration Manual.

1994. Weaver W.E. and D.K. Hagans. Handbook for Forest and Ranch Roads. Mendocino County Resource Conservation District

RD-1.14 ROAD SURFACE UPGRADE

DESCRIPTION

The road surface can be a big source of stream sediment. In some watersheds, it may be the primary source of accelerated (human-caused) erosion and sediment yield from the road system. Proper road construction and surfacing can significantly reduce this source of fine sediment. Permanent roads that are to be used for winter and wet weather hauling, including ranch roads and roads used for commercial hauling of forest products, need to be surfaced to improve trafficability and reduce erosion. Roads which receive heavy use should be inspected regularly to discover early signs of damage. Serious damage to road surfaces usually begins with the build up of thick (1-4 inch) accumulations of dry dust during the summer, or excess water (and mud) during the winter. Standing water is a sign of poor road drainage and ruts indicate that road strength is deteriorating.

BEST MANAGEMENT PRACTICES

- Follow Road BMPS in RD-1.4 Road Surfacing.
- A stable and well drained subgrade is essential for a good road. The load bearing capacity of a road depends upon the subgrade's soil strength, drainage and compaction characteristics (Table 23). Native material is often suitable, and can be used for the road's subgrade. Weak or wet subgrades (soils unable to support a load by themselves) need to be strengthened by adding loose or crushed rock or gravel to provide ballast and distribute the stress placed on the soil.
- Wet, low strength soils may be stabilized by the use of synthetic fabrics (geotextiles) designed specifically for this application. The fabric is spread over the subgrade and then covered with a layer of rock. Water passes through the membrane, but the wet soil remains below and does not mix with the surface aggregate. As a result, the road dries faster and the fabric spreads the wheel loading pressures over a large surface area.
- The running surface of the road should be smooth and hard-wearing, and it should not be subject to blowing or washing away. The most commonly used surfacing materials are angular (crushed) rock. In the past, river-run gravel was frequently used where crushed rock was not readily available. However, rounded material is not as well suited as long lasting surfacing material and may be difficult to keep in-place.
- First, a "base course" of 2 to 3 inch diameter angular rock is usually dumped on the compacted native road surface using dump trucks, spread to a uniform depth using a grader or tractor and then compacted. The use of true compaction equipment (instead of tractors) will provide the best, longest lasting road surface. Geotextile engineering fabrics can be used beneath the base course material if soil conditions are wet. A finer "surface course" several inches in thickness is then spread over the compacted base course material to provide a dense, smooth running surface. The resulting layers of angular, interlocking rock will provide a low impact road surface that can be used during much of the winter (Table 24) (Figure 1).
- For all-weather use, angular rock should be placed to a total depth of 6-10 inches, or more, which will then compact to a finished depth of 4 to 6 inches under normal use. Table 24 lists the volume of aggregate needed to surface one mile of road, ranging from 10-20 feet wide, to a depth of 1-6 inches.

| Table 23. Soil characteristics for road subgrade materials ¹ | | | | |
|---|---|----------------------------------|---------------------|---|
| Material type | Strength, compaction and foundation suitability | Drainage | Reaction to frost | Common symbols of soil types ² |
| Clean gravels and clean sand ³ | Good to excellent | Excellent | None to slight | GW, GP, SW, SP |
| Gravels and sands with non-plastic ⁴ fines | Good to excellent | Fair to poor | Slight to high | GMd, SMd |
| Gravels and sands with plastic ⁴ fines | Fair to good | Poor to impervious | Slight to high | GMu, GC, SMu, SC |
| Non-plastic and slightly plastic silts and clays | Poor to fair | Fair to impervious (mostly poor) | Medium to high | ML, CL, OL |
| Medium and highly plastic ⁴ silts and clays | Very poor to poor | Poor to impervious (mostly poor) | Medium to very high | MH, CH |
| Peat and other highly organic soils | Very unstable, poor compaction | Fair to poor | Slight | PT |

¹ W.D.N.R. (1982)

² Unified Soil Classification System (USCS) symbol

³ "Clean" means less than about 12% of the material is smaller than 1/64" (the smallest particle visible to the naked eye)

⁴ Plasticity can be tested by simple field methods, including lightly wetting a hand sample, rolling the fines into a ball and then into a thread before it crumbles.

Non-plastic: a thread cannot be formed, regardless of the moisture content. Low plasticity: after 2-3 times, the molded ball will crumble.

Medium plasticity: After 3-5 times, the ball will easily crumble with moderate force (pressed between thumb and forefinger).

High plasticity: ball will not crumble, even with moderate force, after five times.

Table 23. From Weaver and Hagans (1994).

Figure 1. Cross section diagram showing typical base-course and surface-course application for forest and ranch roads (USDA_SCS, 1983). From Weaver and Hagans (1994).

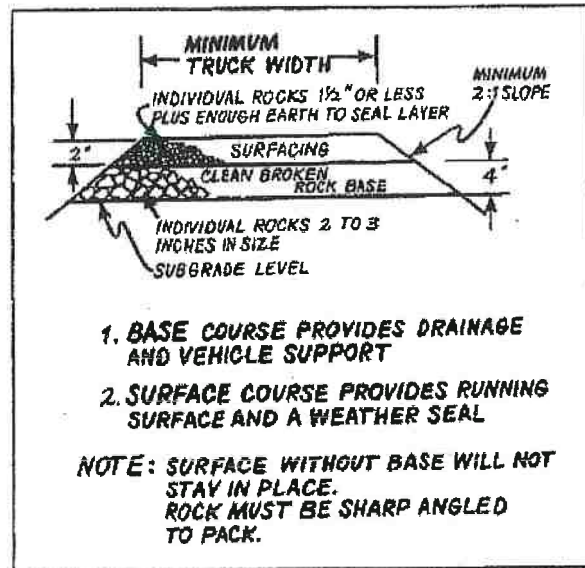

Table 24. Aggregate (yds³) required to one mile of road¹

| Road width (ft) | Depth of uncompacted rock (inches) | | | | | |
|-----------------|------------------------------------|-------|-------|-------|-------|-------|
| | 2" | 4" | 6" | 8" | 10" | 12" |
| 10' | 326 | 652 | 978 | 1,304 | 1,630 | 1,956 |
| 12' | 391 | 782 | 1,174 | 1,564 | 1,956 | 2,348 |
| 14' | 456 | 913 | 1,369 | 1,826 | 2,282 | 2,738 |
| 16' | 522 | 1,043 | 1,565 | 2,086 | 2,608 | 3,130 |
| 18' | 587 | 1,174 | 1,760 | 2,348 | 2,934 | 3,520 |
| 20' | 652 | 1,304 | 1,956 | 2,608 | 3,260 | 3,912 |

¹ USDA (1978). Uncompacted, 16.3 yds³ equals 1 inch deep by 1 foot wide by 1 mile long. When aggregate is compacted, increase volumes required by 15-30%, depending on type and gradation of material.

From Weaver and Hagans (1994).

Source Material for Road BMP RD-6.2 Road Surface Upgrade

1994. Weaver W.E. and D.K. Hagans. Handbook for Forest and Ranch Roads. Mendocino County Resource Conservation District

RD-1.15 ROUTING AND LOCATION

DESCRIPTION

Roads should be plotted and located by a person with some knowledge of the area to be served by the road and of the terrain where the road is to be built. An engineer or geologist should be consulted in routing forest system roads to identify unstable terrain and to protect aquatic resources.

LIMITATIONS

Road system layout is influenced by many factors, including topography, property lines, obstacles (rock outcrops, unstable areas, etc), and proposed land use activities. Controls on the location of a road include both natural features and man-made elements (Table 1).

| Table 1. Some Man-Made Controls Which Affect Road Location¹ | |
|---|--|
| Control | Comment |
| Legal | Boundary lines limit the location of a road. Talk with adjacent landowners and work out written right-of-way agreements to share roads and reduce road construction. |
| Specific Location | The beginning and ending points of a road are often fixed. These represent major controls. |
| Safety | Each class of road and level of use have specific safety requirements. Common sense should be applied in setting speed, grades, curve radius, sight distance, and turnouts. |
| Pollution Control | Roads should avoid problem areas. Allow ample room to trap sediment in a buffer before it reaches a stream. Do not allow any direct discharge points where road runoff flows directly into the stream. Avoid flood plains, landslides, credible soils, etc., as well as slopes over 40% wherever possible. |
| Design Elements | Physical limits for curve radius, road grade, pitch grade, stopping distance and separation from streams are set by you. Design to reduce maintenance costs and pollution potential. |
| Migrating Fish | Observe and maintain substantial buffers. Know what species use your streams, their habitat requirements, the susceptible periods of their life cycle, and their environmental tolerance limits. Permits may be needed from the Department of Fish and Game. |
| Approach Roads Permits | Issued by California Department of Transportation of the County for roads connecting to public highways. Location for intersections may be restricted. |

From Hagans and Weaver (1994). ¹ Adapted from USD A-SCS (1981).

BEST MANAGEMENT PRACTICES

- Identify and map the following conditions on the ground during the road layout process (Table 10):
 - favorable topography (especially benches and low gradient areas for landings turnouts and spoil disposal)
 - control points (the beginning and ending points, saddles and other sites)
 - obstacles (especially unstable or erodible soils, large rock outcrops and wet areas)
 - stream channels (including their degree of incision)
 - inner gorge locations
 - areas of steep slopes
 - any other obvious hazards or controls

| Control | | Comment |
|--------------------------------------|----------------|---|
| Saddles | | Major control for road location |
| Ridges | | Major control and often a satisfactory road site. |
| Stream crossings | | Major control. Seek locations with gentle side slopes and locations wide enough to accommodate the road. Good sites for bridges or culverts are needed. Evaluate for migratory fish where needed. Will need Fish and Game 1603 permit. |
| Benches | | Often a good location for road junctions, switchbacks, landings, turnouts, etc. |
| Cliffs or rock outcrops | | Cross above or below at a safe location. Rock which can be ripped is less costly to remove than hard rock needing blasting. |
| Slides | | Major control. Avoid or cross at the safest point. Ask for professional geotechnical assistance. |
| Wetlands (bogs, swamps, wet meadows) | | Major control. Avoid where possible or cross quickly at best point. May need Fish and Game clearance. |
| Valley floor | wide | Low gradient, desirable road location if above the flood line. If crossing, cross and get out of floodplain quickly. Little excavation required. Fish and Game permit may be required. |
| | narrow | Poor location because of flooding, erosion and pollution potential and high costs to cross the stream if it meanders. Keep road above floodplain. Fish and Game 1603 permit may be required. |
| Slopes | >40%, but <60% | Avoid sidecasting and sliver fills (thin blankets of fill placed on steep slopes) in which large bare areas are exposed to erosion. This loose sediment may be difficult to control because of long buffers needed. |
| | ≥60% | Construction in unstable areas should be avoided. Full bench road construction and earthmoving material may be needed where slopes remain steep alongside stream channels. Proceed only with extreme caution. Avoid road construction on these steep slopes if possible. |
| | ridge crest | Good alignment and little excavation. Good drainage. Few culverts required. Adverse grade encountered on uneven ridges. Spur roads will have an adverse grade. |
| Aspect | | Maintenance requirements in moist climates can be minimized by placing roads on south-facing slopes to promote drying and snow melt. In dry climates, the north-facing slopes have more vegetation and may have less erosion. Extremely wet or dry climate negates this effect. |
| Rock slope (dip) | | Place roads on the hillside where rocks dip (stand) into the hillside, not parallel to or out of the hillside. Consult a geologist for other problems and advice. |
| Soils | | Where possible, avoid road building on naturally erodible soils. Check soils maps for potential problems and ask extension agents or the SCS for advice. Frozen soils require special care; ask for assistance. |

From Weaver and Hagans (1994). ¹ Adapted from USDA-SCS (1981)

- Identify and evaluate nearby rock outcrops for potential rock aggregate for road surfacing materials.
- Identify broad ridge crests and benches as possible locations for landings, road turnouts and spoil disposal sites (Figure 1).
- Locate switchback with little or no grade so that trucks and equipment can pass safely and so they won't tear up the road surface while turning the corner and continuing up the road.

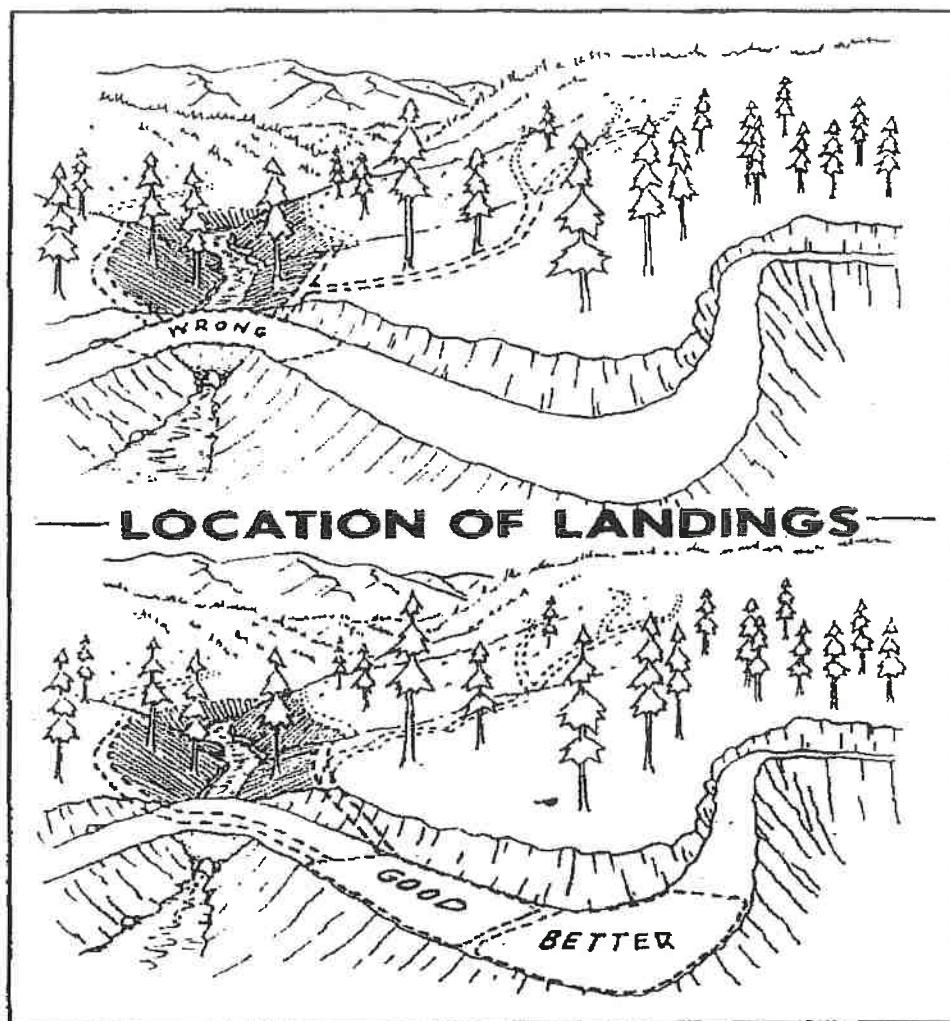

Figure 1.. Log landings on forest road systems should be kept to the absolute minimum size necessary to accommodate yarding, loading and hauling equipment and the minimum number needed to remove timber resources. Landings constructed on gentle ground and broad ridge crests far removed from stream channels are least likely to cause water quality problems, whereas landings built on steep slopes and near watercourses can result in severe impacts. From Weaver and Hagans (1994). Adapted from (USFS, 1963).

For more information, see Handbook for Forest and Ranch Roads. Weaver and Hagans (1994) and consult a trained engineer or geologist before construction. A trained wildlife biologist may be required to investigate for endangered species or species of special concern. An archaeologist may occasionally be needed to identify cultural sites that have to be avoided or mitigated before construction can begin.

Source Material for Road BMP RD-1.2 Routing and Location

1994. Weaver W.E. and D.K. Hagans. Handbook for Forest and Ranch Roads. Mendocino County Resource Conservation District

RD-1.16 UNDERSTANDING ROAD REMOVAL

DESCRIPTION

Approaches to removing roads may be divided into six categories: closure, abandonment, reclassification as trail, decommissioning, conversion to trail, and obliteration (Figure 1).

REMOVAL OPTIONS

Closure

Some agencies close roads with gates, berms, or deep ditches (tank traps) as an approach to road removal (see Road BMP RD-7.3 Road Closure). On-the-ground surveys indicate that conventional closure devices are ineffective at stopping road use by people intent on accessing restricted areas. With an effective device that prohibits motorized access, however, closure may reduce a road's terrestrial impacts by providing wildlife security. Even so, closure is an ineffective approach to removing a road, because the road continues to disrupt natural drainage patterns, cause soil erosion, and potentially initiate mass failures; in short, a closed road continues to impact aquatic ecosystems.

Abandonment

When a road is "abandoned," it is no longer maintained and may or may not be driveable based on physical conditions or the presence of vegetation. The Forest Service considers road abandonment a "no-action treatment" (Moll 1996). Like a closed road with an effective closure device, abandoned roads that no longer receive motorized use may reduce a road's terrestrial impacts by providing wildlife security. Simply discontinuing maintenance and abandoning a road, however, rarely prevents continuing and potential hydrologic problems. The presence of vegetation may provide the false idea that the road is recovering and is no longer problematic. Culverts can become plugged, and roads may continue to function as surface flow paths for water. Road fills may remain unstable and susceptible to failure. Because an abandoned road continues to impact aquatic ecosystems, abandonment is an ineffective approach to removing a road.

Reclassification as Trail

Reclassifying a road as a trail without restoring drainage patterns and stabilizing fill materials is not an effective approach to removing a road, especially if motorized use continues. Even if wildlife security is improved by stopping motorized use, simply reclassifying a road as a trail does not address a road's aquatic impacts; this type of approach is basically the same as abandonment. If a road is changed to a trail, it must be actively converted (see "Conversion to trail" below) by first stabilizing fill materials and dispersing concentrated water.

Decommissioning

Decommissioning is carried out to minimize shortterm sediment production, while "storing" a road for future use. Major treatments include removing stream crossings and stabilizing sidecast fill material. Site-specific drainage treatments such as constructing cross road drains, removing inboard ditches, and/or outsloping also help disperse concentrated water. Road surfaces may be mechanically scarified to facilitate revegetation. The goal of decommissioning is to leave much of the road prism intact so the road can be reconstructed in the future with only minimal effort. Decommissioning preserves most of the original construction investment, while reducing road-caused erosion and avoiding maintenance and/or repair costs. Other common terms used to indicate road removal with plans for future reconstruction

include storm-proofing, flood-proofing, erosion-proofing, putting-to-bed, deactivation, reclamation, hydrologic closure, hydrologic obliteration, and storage for future use. Planning for reconstruction and leaving much of the road prism intact may result in treating a road too lightly during removal. Future plans may change; post-decommissioning is too late to further treat the road for the long-term. Even if decommissioning stops road-related erosion in the shortterm, it is not the same as obliterating a road because the road is expected to be reconstructed. Even if roads may be reconstructed in the future, they should be removed as if reconstruction will not occur.

Conversion to Trail

Converting a road to a modest walking trail can be an effective approach to removing a road if all fill materials are stabilized before the trail is constructed. Some road-to-trail conversions are implemented by only partially recontouring a road, which may not stabilize all fill materials. Conversion is ineffective when ORVs are allowed because impacts associated with motorized use continue. Though trails are less intrusive and damaging than roads, they can cause similar impacts, such as stream sedimentation and facilitation of non-native species invasions.

Obliteration

Obliteration involves removing a road with no plans for future reconstruction. To be most effective, obliteration restores the original landform to the greatest extent possible. Stream crossings are removed and slopes are recontoured. Road surfaces and fill sites are ripped to improve subsurface water flow. Coarse woody debris placed on the recontoured road surface provides erosion protection, long-term nutrient sources, and wildlife habitat. Revegetation is also actively carried out with native species collected near the site. Fully obliterating roads speeds the restoration and recovery of hydrologic function, as well as ecological and evolutionary processes. If implemented appropriately, obliteration is the most effective approach to road removal since it addresses both terrestrial and aquatic impacts caused by roads.

| Road impact considerations | How different approaches to removing roads address road impact considerations | | | | | |
|---|---|------------------------|--------------------------------|---------------------------|--------------------------------|------------------|
| | Close | Abandon | Reclassify as trail | Decommission | Convert to trail | Obliterate |
| Is wildlife security improved? | Yes* (short-term) | Yes (long-term) | Depends on extent of trail use | Yes* (short-term) | Depends on extent of trail use | Yes* (long-term) |
| Are fill stability problems fixed? | No | No | No | Yes* (short-term) | Yes* | Yes* |
| Is surface erosion controlled? | No | No | No | Yes* (short-term) | No* (much reduced) | Yes* |
| Will the road be reopened or reconstructed? | Yes | No | No | Yes | No | No |
| Is motorized use accommodated? ** | Yes | Yes (unless overgrown) | Yes | No* | Yes | No* |
| Will continued maintenance and repair funding be necessary? | Yes | No | Yes | No* (until reconstructed) | Yes | No* |
| * if implemented effectively ** decommissioned and obliterated roads may continue to accommodate winter use by snowmobiles | | | | | | |

Figure 1. From Bagley (1998).

REMOVAL TREATMENT OPTIONS

Specific road removal treatments include removing stream crossings, constructing cross road drains, ripping, recontouring, and outsloping. Each treatment is summarized below.

Stream Crossing

Stream crossing removal is a fundamental treatment for removing roads. When done correctly, stream crossings are removed by excavating all fill materials and restoring the original channel and valley shape. Simply removing culverts is not enough, because any remaining road fill will erode into the channel. Materials excavated from stream crossings can be used to recontour road segments to their natural slope, essentially returning fill to the location from which it was cut. Endhauling is necessary when the amount of fill removed is greater than that needed for recontouring. Any road removal project that does not remove stream crossings (or does not remove all fill materials) is not effective and may cause more ecological damage by causing additional sedimentation.

Cross Road Drains

Cross road drains are deep ditches excavated across road surfaces (similar to waterbars, but more substantial) to facilitate drainage on closed roads. They are too deep and steep to be cleared by motor vehicles. Unless spaced frequently enough to disperse concentrated water, cross road drains may cause erosion downslope. They must be constructed more frequently on roads with steep grades, but are not necessary if roads are fully recontoured or outsloped steeply.

Ripping

Ripping involves decompacting road surfaces and fill sites to a depth of two to three feet. The goal is to enhance subsurface water flow by reducing soil density and increasing porosity, infiltration, and percolation. Ripping relatively impermeable fill sites reduces the chance of fill saturation and failure. Some soil settling occurs since organic matter is limited in sterile road soils. Therefore, adding organic matter to the ripped soil can greatly accelerate the recovery of hydrologic function, including both infiltration and percolation (Luce 1997). Ripping also increases revegetation success.

Recontouring

Recontouring involves placing all fill materials back into locations where fill was removed during road construction. Recontouring restores the original slope as much as possible, dispersing concentrated water and greatly enhancing slope stability. Full recontouring is sometimes impossible, especially on very steep slopes, since the sidecast material may have slid downhill out of reach. In some cases, cutslopes will be so high and road cuts so narrow, that replaced fill material will not blend with the original undisturbed slope. Even so, slope recontouring to the extent possible generally results in the most stable landform shape, restores natural surface runoff patterns, and deters motorized access.

Outsloping

Outsloping involves filling inboard ditches with sidecast fill material and sloping the road surface to disperse water to the downhill side of the road. Some sidecast fill materials remain, but saturation and potential failure is reduced because water cannot concentrate in inboard ditches or on the road surface. The remaining fill slope materials may still cause stability problems, especially on steep slopes.

Source Material for Road BMP RD-7.2 Understanding Road Removal

1983. Bagley, Scott. The Road-Ripper's Guide to Wildland Road Removal. Wildlands Center for Preventing Roads

1994. Weaver W.E. and D.K. Hagans. Handbook for Forest and Ranch Roads. Mendocino County Resource Conservation District

RD-1.17 ROAD CLOSURE

DESCRIPTION

Road closure is an effective tool in managing road systems to protect private property, road systems, water quality, and sensitive landscapes. Choosing the access control treatment depends on the type of vehicle access to be discouraged and the length of the closure (Table 1). For example, closure treatments can be designed to discourage motorized traffic, but allow mountain biking or walking access. Closure treatments can also be designed to permanently close a road or allow seasonal treatments. The closure treatment chosen should reflect both the short term and long term use of the road system.

BEST MANAGEMENT PRACTICES

| Closure Type | Description | Purpose Application |
|---------------------------------|---|--|
| Blockage with On-Site Materials | Rock, logs, stumps, slash piles, posts, water bars, tank traps, decomposition | Discourage use, economical, dependent on-site and available material |
| Vegetative Planting, Seeding | Trees, shrubs, cactus, and grass seeding, recycled paper mulch, chip and spread slash | Discourage use, camouflage road, speed revegetation and healing of site, provide browse and forage |
| Imported Material | Fences, gates, posts, guardrails, concrete barriers | Discourage use, lack of on-site material or inappropriate site for use of on-site materials |
| Pole Fences Wood Barriers | Onsite or imported poles, reinforce with metal strips to deter chain-sawing | Discourage use, can be dismantled for emergency access, aesthetically pleasing |
| Closure Devices | Materials used include metal telescoping tubing, pipe, and well casing. Available in single lane to double lane widths | Discourage use, allow quick easy access, single or multiple locks, signing |
| Obliteration | Re-contour road junction or entire road. Combine with other closure treatments. Removal of drainage structures, bridges, and associated embankments | Eliminate travelway, return corridor to resource production, reduce modifications to hydrology and aesthetics, camouflage road |

Table 1. Access Control Treatments. Adapted from US Forest Service 1996.

Source Material for Road BMP RD-7.3 Road Closure

1996. US Forest Service. A Guide for Road Closure and Obliteration in the Forest Service. Technology and Development Program. Publication: 9677 1205.

EC-1.1 JUTE MAT BLANKET

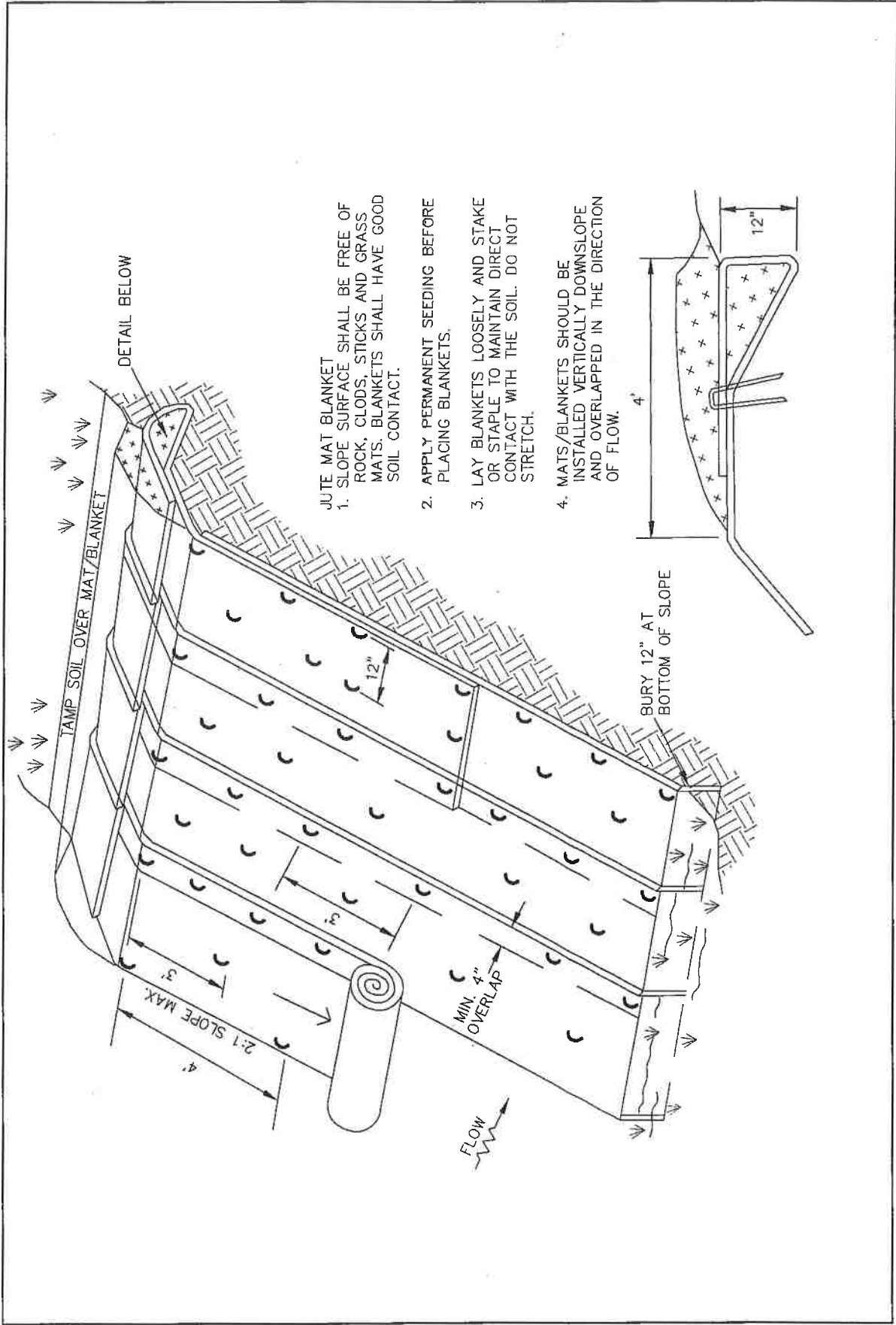

- JUTE MAT BLANKET
1. SLOPE SURFACE SHALL BE FREE OF ROCK, CLODS, STICKS AND GRASS MATS. BLANKETS SHALL HAVE GOOD SOIL CONTACT.
 2. APPLY PERMANENT SEEDING BEFORE PLACING BLANKETS.
 3. LAY BLANKETS LOOSELY AND STAKE OR STAPLE TO MAINTAIN DIRECT CONTACT WITH THE SOIL. DO NOT STRETCH.
 4. MATS/BLANKETS SHOULD BE INSTALLED VERTICALLY DOWNSLOPE AND OVERLAPPED IN THE DIRECTION OF FLOW.

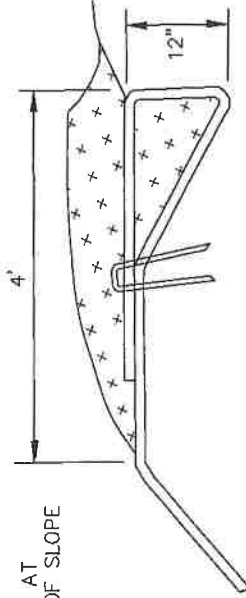

EC-1.2 CULVERT OUTLET ENERGY DISSIPATER

DESCRIPTION

An energy dissipater is a structure designed to control erosion at the outlet of a culvert or conduit by reducing the velocity of flow and dissipating the energy (see BMP SS-10 Outlet Protection/Velocity Dissipation Devices).

LIMITATIONS

- Do not use this BMP below the mean high water line of any water body before obtaining appropriate permits. Due to issues relative to Corps 404 jurisdiction sometimes energy dissipaters are not placed below the ordinary high water mark which results in increased erosion.
- Consider other energy dissipaters such as concrete impact basins, paved outlet structures, or a half culvert where site conditions warrant.
- Rock/riprap dissipaters may require containment in mattresses to maintain their effectiveness.

BEST MANAGEMENT PRACTICES

- Size rock to handle high velocity storm events.
- Key rock into sides of fillslope to prevent undercutting (Figure 1).
- Best results are obtained when sound, durable, angular rock is used (Figure 2).
- Inspect after each significant rain for erosion and/or disruption of the rock, and repair immediately.

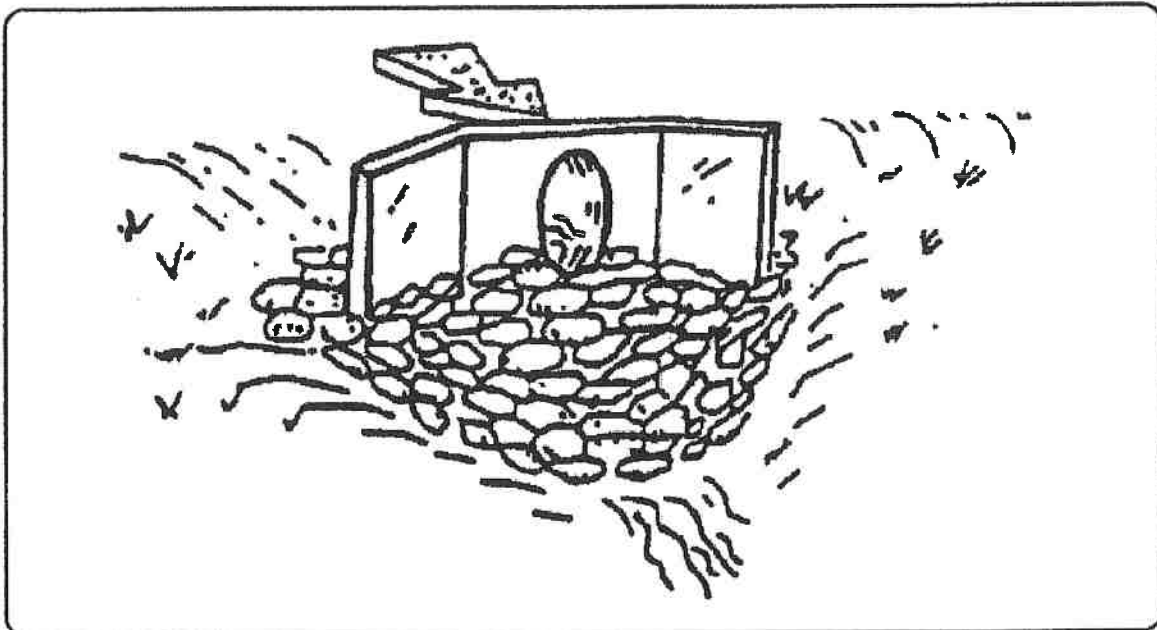

Figure 1. Flared outlet with rock energy dissipater. From Weber County, UT.

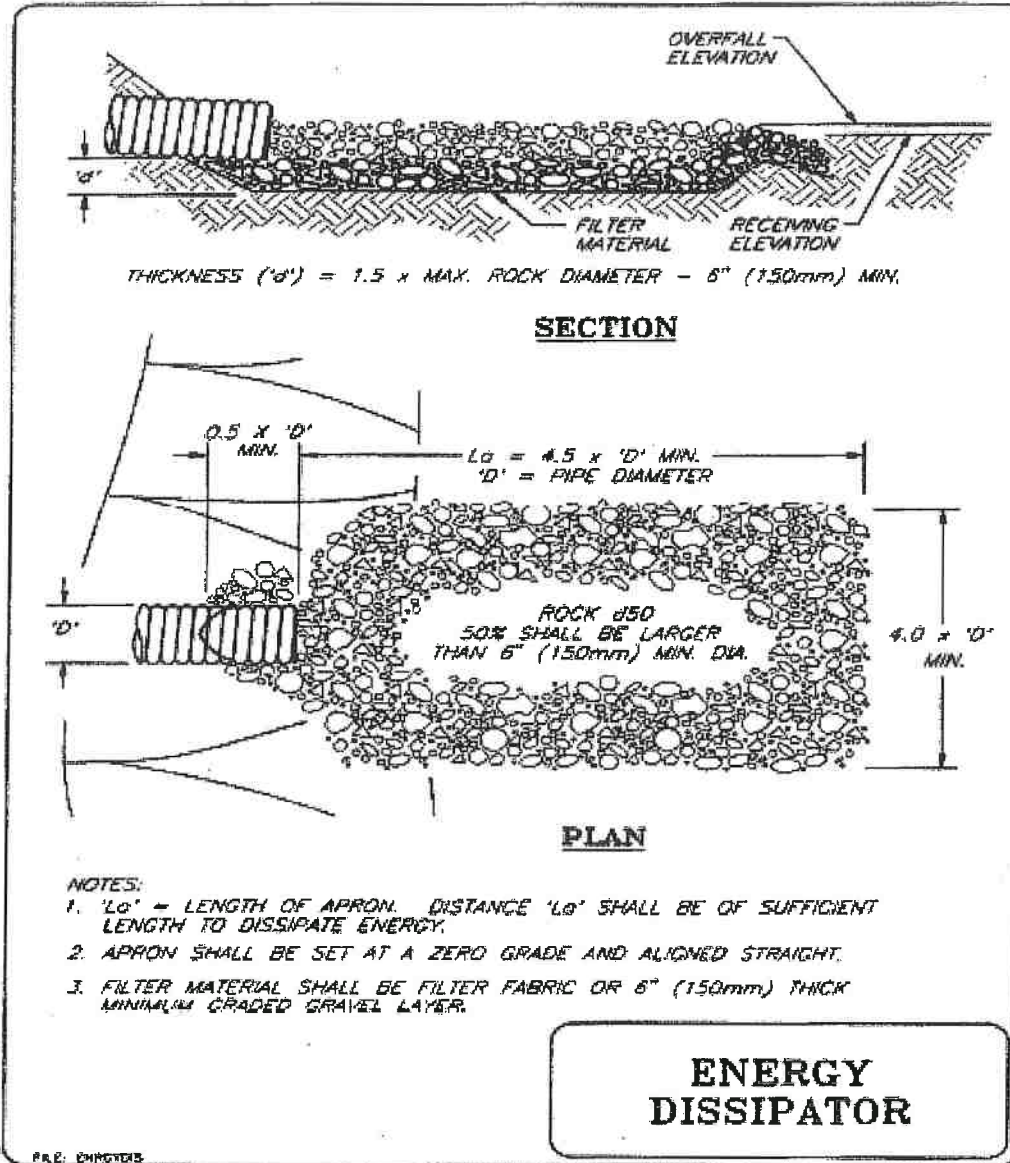

Figure 2. Rock energy dissipater. From 2004 Fishnet 4C. Adapted from 1994 McCullah.

Source Material for Road BMP RD-2.12 Culvert Outlet Energy Dissipater

2004. FishNet 4C. Guidelines for Protecting Aquatic Habitat and Salmon Fisheries for County Road Maintenance.

N/A. Weber County, Engineering Department. Ogden, Utah.

EC-1.3 OUTLET PROTECTION

DESCRIPTION

A rock outlet protection is a physical device composed of rock, riprap, grouted riprap, or concrete rubble which is placed at the outlet of a pipe to prevent scour of the soil caused by high pipe flow velocities, and to absorb flow energy to produce nonerosive velocities (see Construction BMP SS-10 Outlet Protection/ Velocity Dissipation Devices).

APPLICATIONS:

- Wherever discharge velocities and energies at the outlets of culverts, conduits, or channels are sufficient to erode the next downstream reach.
- Rock outlet protection is best suited for temporary use during construction because it is usually less expensive and easier to install than concrete aprons or an energy dissipater (Figure 1) (see Erosion Control BMP EC-1.3 Energy Dissipater).
- A sediment trap below the pipe outlet is recommended if runoff is sediment laden (Figure 2).
- Permanent rock riprap protection should be designed and sized by the engineer as part of the culvert, conduit or channel design (Figure 2).
- Grouted riprap should be avoided in areas of freeze and thaw because the grout will break up.

LIMITATIONS

- Large storms often wash away the rock outlet protection and leave the area susceptible to erosion.
- Sediment captured by the rock outlet protection may be difficult to remove without removing the rock.
- Outlet protection may negatively impact the channel habitat in streams.

BEST MANAGEMENT PRACTICES

- Size rock to handle high velocity storm events (Figure 3).
- Key rock into sides of fillslope to prevent undercutting.
- Best results are obtained when sound, durable, angular rock is used.
- Inspect after each significant rain for erosion and/or disruption of the rock, and repair immediately.

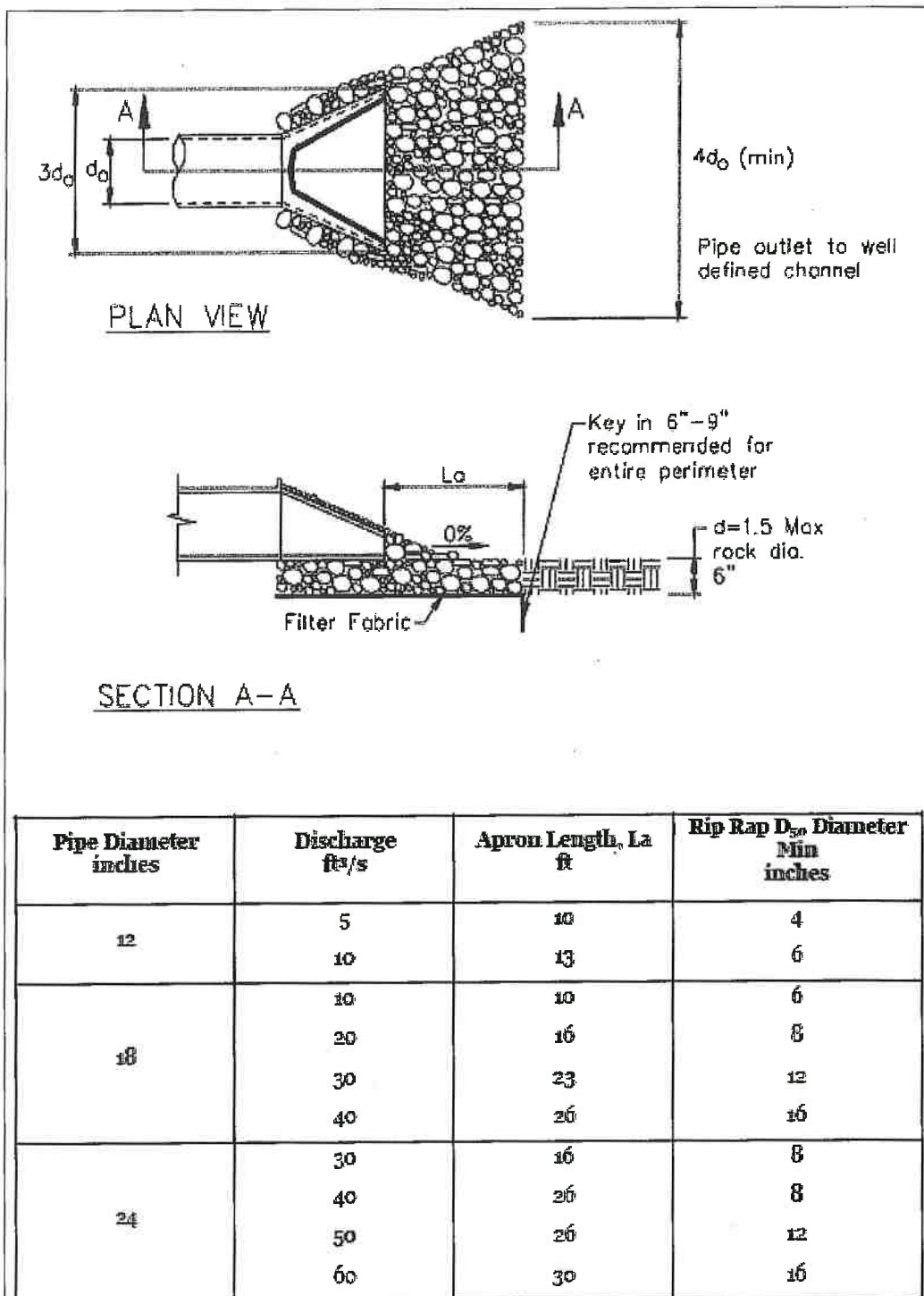

Figure 1. Flared outlet with energy dissipater. From Caltrans (2003). (Adapted from USDA-SCS).

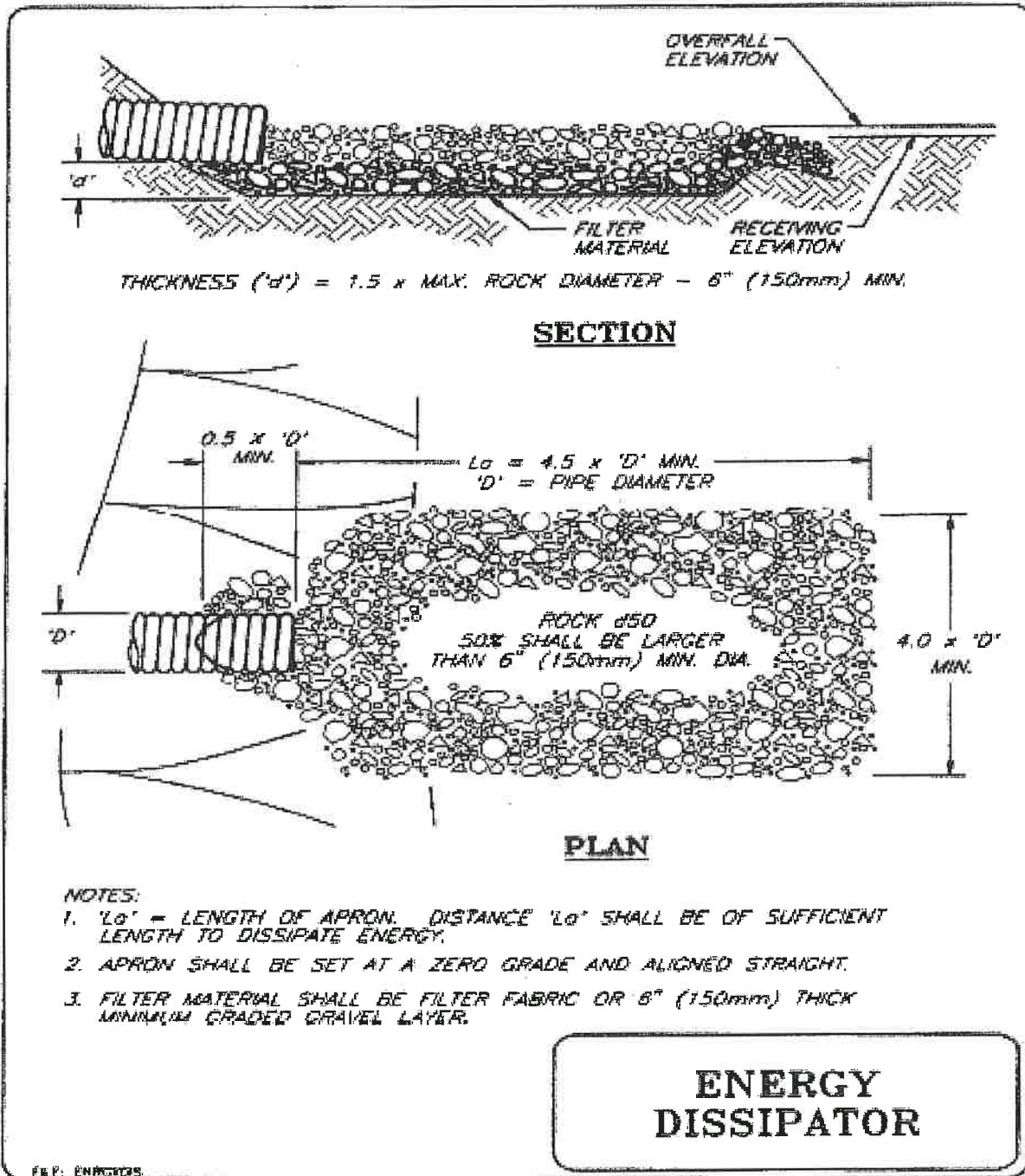

Figure 2. Rock energy dissipator. From 2004 Fishnet 4C. Adapted from 1994 McCullah.

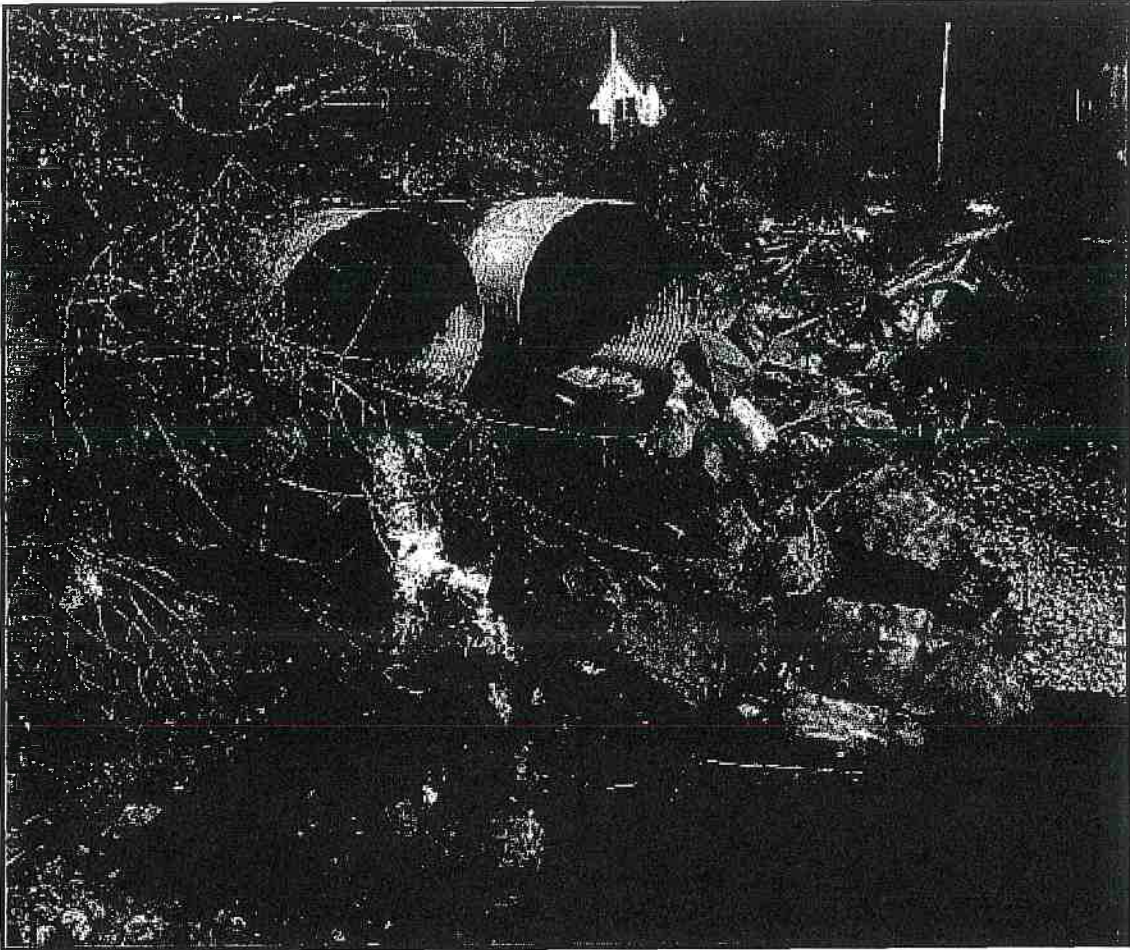

Figure 3. Rock armoring on shotgun culvert outlet. Photo Courtesy of California Department of Transportation (Caltrans).

Source Material for Road BMP RD-2.11 Outlet Protection

2003. California Department of Transportation (CALTRANS). Storm Water Quality Handbooks – Construction Site Best Management Practices (BMPs) Manual.

2004. FishNet 4C. Guidelines for Protecting Aquatic Habitat and Salmon Fisheries for County Road Maintenance.

EC-1.4 STOCKPILE MANAGEMENT

DESCRIPTION

This activity involves the selection of sites in advance of the need for long-term and short-term stockpiling of materials for road maintenance activities and disposing of excess materials from excavations, grading and culvert basin cleaning. The general watershed criteria for selecting any disposal site is a site where the material will not erode into any part of the channel network, and where it will not initiate a formerly dormant landslide.

ENVIRONMENTAL CONCERNS

- Filling wetlands with spoil material.
- Discharge of sediment, debris, or organic material into the stream or storm water discharge system.
- Destruction or harm to aquatic, riparian or wetland habitat, or to endangered or threatened plant and animal species due to placement of fill material.
- Surface or groundwater impacts from leachate formed in organic material disposal sites.
- Damage to endangered or threatened plant species on site.
- Slope stability of both the disposal site and the spoil pile.

BEST MANAGEMENT PRACTICES

Site Selection

- Determine the location of existing disposal sites, potential disposal sites, and locations of significant spoil generation along roads.
 - Conduct site investigations of existing and potentially suitable disposal sites. Site investigations should include the disposal area size, distance to watercourses, potential slope instabilities, listed species habitat, archaeological sites, nearby residential areas, access, and other limiting factors.
 - Prepare a map and data set indicating sites (existing and potential) with acceptable site characteristics (see below). Prioritize acceptable sites.
 - Develop site plans for sites adjacent to or near riparian areas or streams to identify erosion and sediment control needs, and to ensure stability of the material.
- Follow these acceptable site characteristics in the site election & design process:
 - Seek a stable site where sediment cannot reach the stream during any high water event.
 - Avoid adjacent riparian corridors or any area within the 100-year floodplain.
 - Avoid all wetland sites as these sites are protected from disposal activities and permits will be required and may not be granted.
 - Avoid placing spoil on unstable slopes, where the added weight could trigger a land movement. Excessive loading of clay or silt soils could also trigger a failure.
 - Use wide, stable locations such as rock pits, ridges, and benches as places to dispose of fill. Avoid locations where ground water emerges or a thick organic layer is present. Do not leave loose soil piled in berms alongside the road or ditch.

- Avoid sites with endangered or threatened plant species. Search the California Natural Diversity Database (www.dfg.ca.gov/whdab/html/cnddb.html) for any known listed plant sites in the area. Seek site evaluations by qualified botanists during the appropriate season before selecting a new site.

Implementation

- Locate stockpiles a minimum of 50 ft away from concentrated flows of stormwater, drainage courses, and inlets.
- Protect all stockpiles from stormwater run-on using a temporary perimeter sediment barrier such as berms, dikes, fiber rolls, silt fences, gravel bags, or straw bale barriers.
- During the rainy season, soil stockpiles should be covered or protected with soil stabilization measures and a temporary perimeter sediment barrier at all times.
- During the non-rainy season, soil stockpiles should be covered or protected with a temporary perimeter sediment barrier prior to the onset of precipitation (Figure 1).
- Apply erosion and sediment control BMPs as needed.
- Place bagged materials on pallets and under cover.
- Implement wind erosion control practices as appropriate on all stockpiled material. For specific information.
- The performance of erosion control BMPs should be monitored routinely during construction, especially during and after storm events. BMPs should be maintained or upgraded as needed.
- Manage stockpiles of contaminated soil in accordance with State and Federal Regulations.
- Avoid sidecasting of soil in all cases where it could be delivered into a watercourse, riparian area, roadside ditch or storm drain. Do not sidecast outside of the landowner right-of-way without landowner's permission. In some instances, under the following guidelines (See Table 1), sidecasting is allowable given remote distances from spoils storage sites. In these cases, the setback distance required depends on slope and vegetation. The presence of vegetation helps to slow the travel of sediment downslope, so good judgment is needed to assess the situation. *Do not sidecast at all* if the slope is sparsely vegetated and it appears that sediment will travel with rain runoff into a stream or estuary system, even if setback distances are applied. On slopes of 5:1 (20% gradient) or less, sidecasting is allowed beyond 150 feet of a watercourse, stream crossing, riparian area, roadside ditch or storm drain. On 2:1 slopes (50%) or less, sidecasting is allowed beyond 300 feet of a watercourse, stream crossing, riparian area, roadside ditch or storm drain. On slopes greater than 2:1, typically sidecasting is *not recommended*, however there may be rare instances on slopes greater than 2:1 where sidecasting is acceptable given very long distances from waterbodies and good vegetative cover. Seek advice from local fisheries agency staff when in doubt. Avoid concentrating sidecasting repeatedly in the same place. Never sidecast large amounts of soil from major landslides.

| SLOPE GRADIENT | DISTANCE FROM WATERCOURSE, STREAM CROSSING, RIPARIAN AREA, ROADSIDE DITCH, STORM DRAIN | SIDECASTING RULE |
|------------------------|--|-----------------------------|
| Any slope | Appears that sediment will travel with rainwater into watercourse. | Not allowed |
| 5:1 (20%) or less | 150 feet or more | Allowed using good judgment |
| 2:1 (50%) or less | 300 feet or more | Allowed using good judgment |
| Greater than 2:1 (50%) | Vegetated slope long distance from watercourse | Allowed |
| Greater than 2:1 (50%) | Sparse vegetated slope and it appears that sediment will travel with rain into watercourse | Not allowed |

Table 1. Sidecasting BMP. From FishNet 4C (2004).

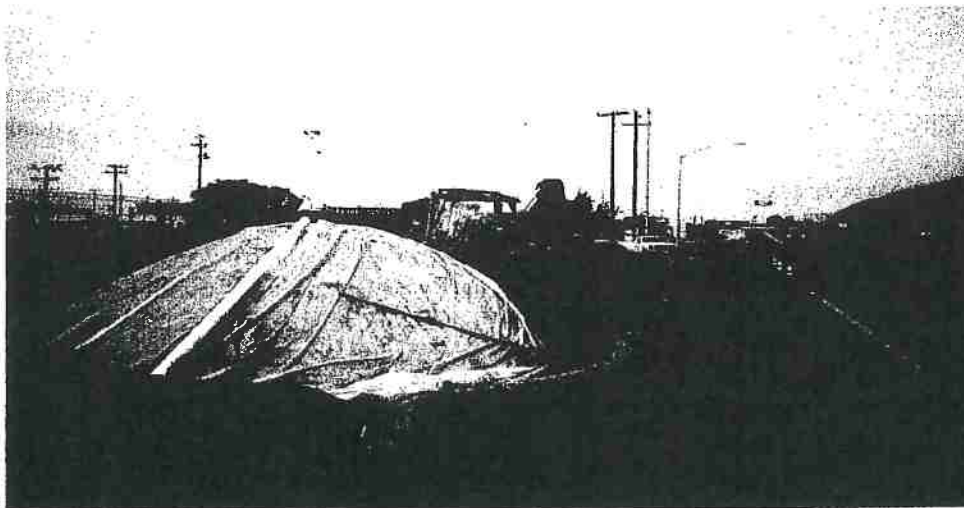

Figure 1. Stock piles should be covered with erosion and sediment control BMPs employed to keep sediment on site. From Caltrans (2003).

Source Material for Road BMP RD-2.16 Stockpile Management

2003. California Department of Transportation (CALTRANS). Storm Water Quality Handbooks – Construction Site Best Management Practices (BMPs) Manual.

2004. FishNet 4C. Guidelines for Protecting Aquatic Habitat and Salmon Fisheries for County Road Maintenance.

Straw Mulch

SS-6

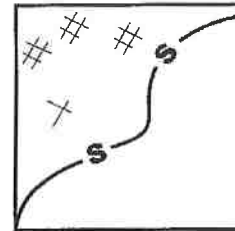

Standard Symbol

- BMP Objectives**
- Soil Stabilization
 - Sediment Control
 - Tracking Control
 - Wind Erosion Control
 - Non-Storm Water Management
 - Materials and Waste Management

Definition and Purpose Straw mulch consists of placing a uniform layer of straw and incorporating it into the soil with a studded roller or anchoring it with a stabilizing emulsion. This is one of five temporary soil stabilization alternatives to consider.

- Appropriate Applications**
- Straw mulch is typically used for soil stabilization as a temporary surface cover on disturbed areas until soils can be prepared for revegetation and permanent vegetation is established.
 - Also typically used in combination with temporary and/or permanent seeding strategies to enhance plant establishment.

- Limitations**
- Availability of erosion control contractors and straw may be limited prior to the rainy season due to high demand.
 - There is a potential for introduction of weed-seed and unwanted plant material.
 - When straw blowers are used to apply straw mulch, the treatment areas must be within 45 m (150 ft) of a road or surface capable of supporting trucks.
 - Straw mulch applied by hand is more time intensive and potentially costly.
 - May have to be removed prior to permanent seeding or soil stabilization.
 - “Punching” of straw does not work in sandy soils.

Straw Mulch

SS-6

- Standards and Specifications
- Straw shall be derived from wheat, rice, or barley.
 - All materials shall conform to Standard Specifications Sections 20-2.06, 20-2.07 and 20-2.11.
 - A tackifier is the preferred method for anchoring straw mulch to the soil on slopes.
 - Crimping, punch roller-type rollers, or track-walking may also be used to incorporate straw mulch into the soil on slopes. Track walking shall only be used where other methods are impractical.
 - Avoid placing straw onto the traveled way, sidewalks, lined drainage channels, sound walls, and existing vegetation.
 - Straw mulch with tackifier shall not be applied during or immediately before rainfall.

Application Procedures

- Apply loose straw at a minimum rate of 3,570 kg/ha (4,000 lb/ac), or as indicated in the project's special provisions, either by machine or by hand distribution.
- If stabilizing emulsion will be used to anchor the straw mulch in lieu of incorporation, roughen embankment or fill areas by rolling with a crimping or punching-type roller or by track walking before placing the straw mulch. Track walking should only be used where rolling is impractical.
- The straw mulch must be evenly distributed on the soil surface.
- Anchor the mulch in place by using a tackifier or by "punching" it into the soil mechanically (incorporating).
- A tackifier acts to glue the straw fibers together and to the soil surface. The tackifier shall be selected based on longevity and ability to hold the fibers in place.
- A tackifier is typically applied at a rate of 140 kg/ha (125 lb/ac). In windy conditions, the rates are typically 200 kg/ha (178 lb/ac).
- Methods for holding the straw mulch in place depend upon the slope steepness, accessibility, soil conditions and longevity. If the selected method is incorporation of straw mulch into the soil, then do as follows:
 - Applying and incorporating straw shall follow the requirements in Standard Specifications Section 20-3.03.
 - On small areas, a spade or shovel can be used.

Straw Mulch

SS-6

- On slopes with soils, which are stable enough and of sufficient gradient to safely support construction equipment without contributing to compaction and instability problems, straw can be “punched” into the ground using a knife-blade roller or a straight bladed coultter, known commercially as a “crimper.”
 - On small areas and/or steep slopes, straw can also be held in place using plastic netting or jute. The netting shall be held in place using 11 gauge wire staples, geotextile pins or wooden stakes. Refer to BMP SS-7, “Geotextiles, Plastic Covers and Erosion Control Blankets/Mats.”
- Maintenance and Inspections
- The key consideration in Maintenance and Inspection is that the straw needs to last long enough to achieve erosion control objectives.
 - Maintain an unbroken, temporary mulched ground cover while DSAs are non-active. Repair any damaged ground cover and re-mulch exposed areas.
 - Reapplication of straw mulch and tackifier may be required by the Resident Engineer (RE) to maintain effective soil stabilization over disturbed areas and slopes.
 - After any rainfall event, the Contractor is responsible for maintaining all slopes to prevent erosion.

Source Material for Construction BMP SS-6

2003. State of California Department of Transportation. Caltrans Storm Water Quality Handbook Construction Site BMP Manual.

Geotextiles, Mats, Plastic Covers and Erosion Control Blankets

SS-7

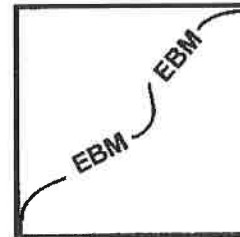
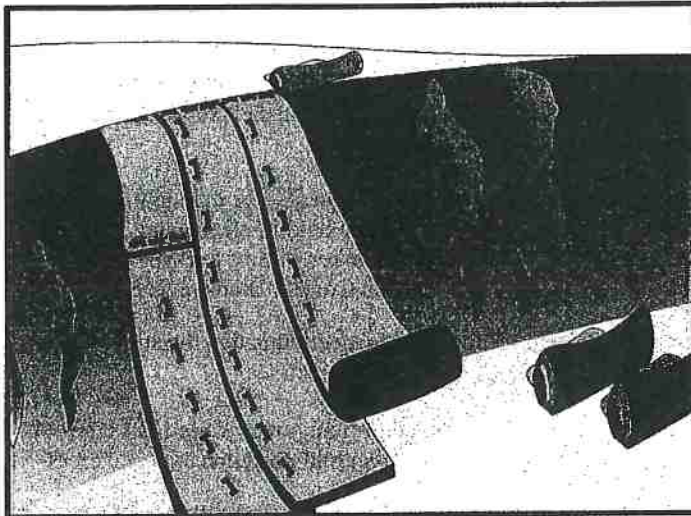

Standard Symbol

BMP Objectives

- Soil Stabilization
- Sediment Control
- Tracking Control
- Wind Erosion Control
- Non-Storm Water Management
- Materials and Waste Management

Definition and Purpose This Best Management Practice (BMP) involves the placement of geotextiles, mats, plastic covers, or erosion control blankets to stabilize disturbed soil areas and protect soils from erosion by wind or water. This is one of five temporary soil stabilization alternatives to consider.

Appropriate Applications These measures are used when disturbed soils may be particularly difficult to stabilize, including the following situations:

- Steep slopes, generally steeper than 1:3 (V:H).
- Slopes where the erosion potential is high.
- Slopes and disturbed soils where mulch must be anchored.
- Disturbed areas where plants are slow to develop.
- Channels with flows exceeding 1.0 m/s (3.3 ft/s).
- Channels to be vegetated.
- Stockpiles.
- Slopes adjacent to water bodies of Environmentally Sensitive Areas (ESAs).

Geotextiles, Mats, Plastic Covers and Erosion Control Blankets

SS-7

- Limitations**
- Blankets and mats are more expensive than other erosion control measures, due to labor and material costs. This usually limits their application to areas inaccessible to hydraulic equipment, or where other measures are not applicable, such as channels.
 - Blankets and mats are generally not suitable for excessively rocky sites, or areas where the final vegetation will be mowed (since staples and netting can catch in mowers).
 - Blankets and mats must be removed and disposed of prior to application of permanent soil stabilization measures.
 - Plastic sheeting is easily vandalized, easily torn, photodegradable, and must be disposed of at a landfill.
 - Plastic results in 100% runoff, which may cause serious erosion problems in the areas receiving the increased flow.
 - The use of plastic shall be limited to covering stockpiles, or very small graded areas for short periods of time (such as through one imminent storm event), until alternative measures, such as seeding and mulching, may be installed.
 - Geotextiles, mats, plastic covers, and erosion control covers have maximum flow rate limitations; consult the manufacturer for proper selection.

**Standards and
Specifications**

Material Selection

There are many types of erosion control blankets and mats, and selection of the appropriate type shall be based on the specific type of application and site conditions. Selection(s) made by the Contractor must be approved by the Resident Engineer (RE); certification of compliance shall be in accordance with Standard Specifications Section 6-1.07.

Site Preparation

- Proper site preparation is essential to ensure complete contact of the blanket or matting with the soil.
- Grade and shape the area of installation.
- Remove all rocks, clods, vegetation or other obstructions so that the installed blankets or mats will have complete, direct contact with the soil.
- Prepare seedbed by loosening 50 mm (2 in) to 75 mm (3 in) of topsoil.

Seeding

Seed the area before blanket installation for erosion control and revegetation. Seeding after mat installation is often specified for turf reinforcement application. When seeding prior to blanket installation, all check slots and other areas disturbed during installation must be re-seeded. Where soil filling is specified, seed the matting and the entire disturbed area after installation and prior to filling the mat with soil.

Geotextiles, Mats, Plastic Covers and Erosion Control Blankets

SS-7

Maintenance and Inspection Areas treated with temporary soil stabilization shall be inspected as specified in the special provisions. Areas treated with temporary soil stabilization shall be maintained to provide adequate erosion control. Temporary soil stabilization shall be reapplied or replaced on exposed soils when area becomes exposed or exhibits visible erosion.

- All blankets and mats shall be inspected periodically after installation.
- Installation shall be inspected after significant rain storms to check for erosion and undermining. Any failures shall be repaired immediately.
- If washout or breakage occurs, re-install the material after repairing the damage to the slope or channel.

Source Material for Construction BMP SS-7 Geotextiles, Mats, Plastic Covers and Erosion Control Blankets

2003. State of California Department of Transportation. Caltrans Storm Water Quality Handbook Construction Site BMP Manual.

Outlet Protection/Velocity Dissipation Devices

SS-10

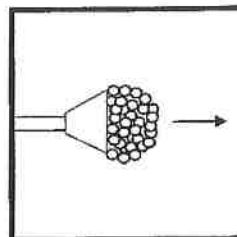
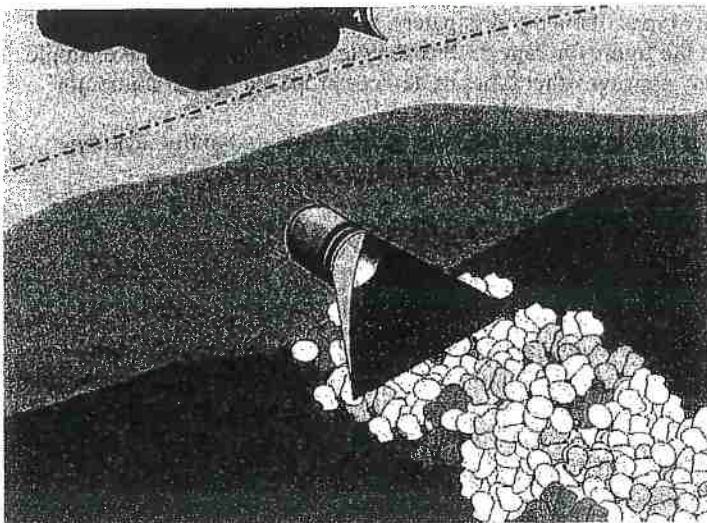

Standard Symbol

BMP Objectives

- Soil Stabilization
- Sediment Control
- Tracking Control
- Wind Erosion Control
- Non-Storm Water Management
- Materials and Waste Management

Definition and Purpose These devices are placed at pipe outlets to prevent scour and reduce the velocity and/or energy of storm water flows.

Appropriate Applications

- These devices may be used at the following locations:
 - Outlets of pipes, drains, culverts, slope drains, diversion ditches, swales, conduits or channels.
 - Outlets located at the bottom of mild to steep slopes.
 - Discharge outlets that carry continuous flows of water.
 - Outlets subject to short, intense flows of water, such as flash floods.
 - Points where lined conveyances discharge to unlined conveyances.
- This BMP may be implemented on a project-by-project basis with other BMPs when determined necessary and feasible by the Resident Engineer (RE).

Limitations

- Loose rock may have stones washed away during high flows.
- Grouted riprap may break up in areas of freeze and thaw.
- If there is not adequate drainage, and water builds up behind grouted riprap, it may cause the grouted riprap to break up due to the resulting hydrostatic pressure.

Outlet Protection/Velocity Dissipation Devices

SS-10

- Standards and Specifications**
- There are many types of energy dissipaters, with rock being the one that is represented in the figure on Page 3. Please note that this is only one example and the RE may approve other types of devices proposed by the contractor.
 - Install riprap, grouted riprap, or concrete apron at selected outlet. Riprap aprons are best suited for temporary use during construction.
 - Carefully place riprap to avoid damaging the filter fabric.
 - For proper operation of apron:
 - Align apron with receiving stream and keep straight throughout its length. If a curve is needed to fit site conditions, place it in upper section of apron.
 - If size of apron riprap is large, protect underlying filter fabric with a gravel blanket.
 - Outlets on slopes steeper than 10% shall have additional protection.
- Maintenance and Inspection**
- Inspect temporary measures prior to the rainy season, after rainfall events, and regularly (approximately once per week) during the rainy season.
 - Inspect apron for displacement of the riprap and/or damage to the underlying fabric. Repair fabric and replace riprap that has washed away.
 - Inspect for scour beneath the riprap and around the outlet. Repair damage to slopes or underlying filter fabric immediately.
 - Temporary devices shall be completely removed as soon as the surrounding drainage area has been stabilized, or at the completion of construction.

Outlet Protection/Velocity Dissipation Devices

SS-10

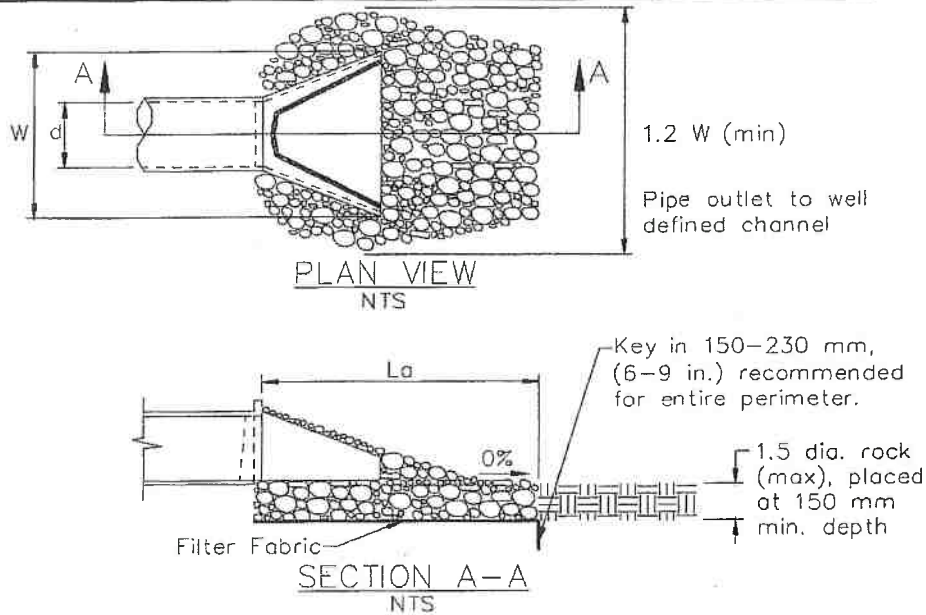

| Pipe Diameter mm | Discharge m ³ /s | Apron Length, La m | Rip Rap D ₅₀ Diameter Min mm |
|---------------------|--------------------------------|-----------------------|---|
| 300 | 0.14 | 3 | 100 |
| | 0.28 | 4 | 150 |
| 450 | 0.28 | 3 | 150 |
| | 0.57 | 5 | 200 |
| | 0.85 | 7 | 300 |
| | 1.13 | 8 | 400 |
| 600 | 0.85 | 5 | 200 |
| | 1.13 | 8 | 200 |
| | 1.42 | 8 | 300 |
| | 1.70 | 9 | 400 |

For larger or higher flows, consult a Registered Civil Engineer

Source: USDA – SCS

Source Material for Construction BMP SS-10 Outlet Protection

2003. State of California Department of Transportation. Caltrans Storm Water Quality Handbook Construction Site BMP Manual.

Slope Drains

SS-11

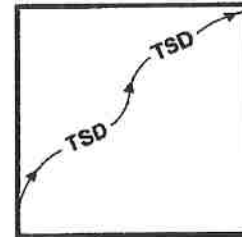
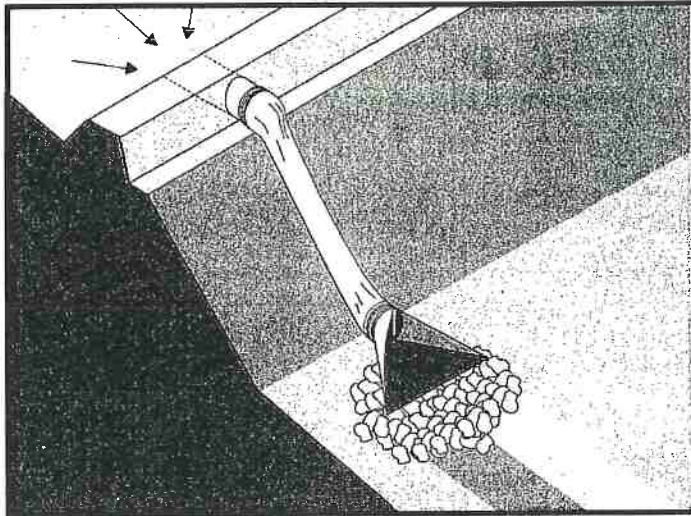

Standard Symbol

BMP Objectives

- Soil Stabilization
- Sediment Control
- Tracking Control
- Wind Erosion Control
- Non-Storm Water Management
- Materials and Waste Management

- Definition and Purpose** A slope drain is a pipe used to intercept and direct surface runoff or groundwater into a stabilized watercourse, trapping device or stabilized area. Slope drains are used with lined ditches to intercept and direct surface flow away from slope areas to protect cut or fill slopes.
- Appropriate Applications**
- Slope drains may be used on construction sites where slopes may be eroded by surface runoff.
 - This BMP may be implemented on a project-by-project basis with other BMPs when determined necessary and feasible by the Resident Engineer (RE).
- Limitations**
- Severe erosion may result when slope drains fail by overtopping, piping, or pipe separation.
- Standards and Specifications**
- When using slope drains, limit drainage area to 4 ha (10 ac) per pipe. For larger areas, use a rock-lined channel or a series of pipes.
 - Maximum slope generally limited to 1:2 (V:H), as energy dissipation below steeper slopes is difficult.
 - Direct surface runoff to slope drains with interceptor dikes. See BMP SS-8, "Earth Dikes/Drainage Swales, and Lined Ditches."
 - Slope drains can be placed on or buried underneath the slope surface.
 - Recommended materials are PVC, ABS, or comparable pipe.
 - When installing slope drains:
 - Install slope drains perpendicular to slope contours.

Slope Drains

SS-11

- Compact soil around and under entrance, outlet, and along length of pipe.
 - Securely anchor and stabilize pipe and appurtenances into soil.
 - Check to ensure that pipe connections are water tight.
 - Protect area around inlet with filter cloth. Protect outlet with riprap or other energy dissipation device. For high energy discharges, reinforce riprap with concrete or use reinforced concrete device.
 - Protect inlet and outlet of slope drains; use standard flared end section at entrance and exit for pipe slope drains 300 mm (12in) and larger.
- Maintenance and Inspection
- Inspect before and after each rain storm, and twice monthly until the tributary drainage area has been stabilized. Follow routine inspection procedures for inlets thereafter.
 - Inspect outlet for erosion and downstream scour. If eroded, repair damage and install additional energy dissipation measures. If downstream scour is occurring, it may be necessary to reduce flows being discharged into the channel unless other preventative measures are implemented.
 - Inspect slope drainage for accumulations of debris and sediment.
 - Remove built-up sediment from entrances, outlets, and within drains as required.
 - Make sure water is not ponding onto inappropriate areas (e.g., active traffic lanes, material storage areas, etc.).

Slope Drains

SS-11

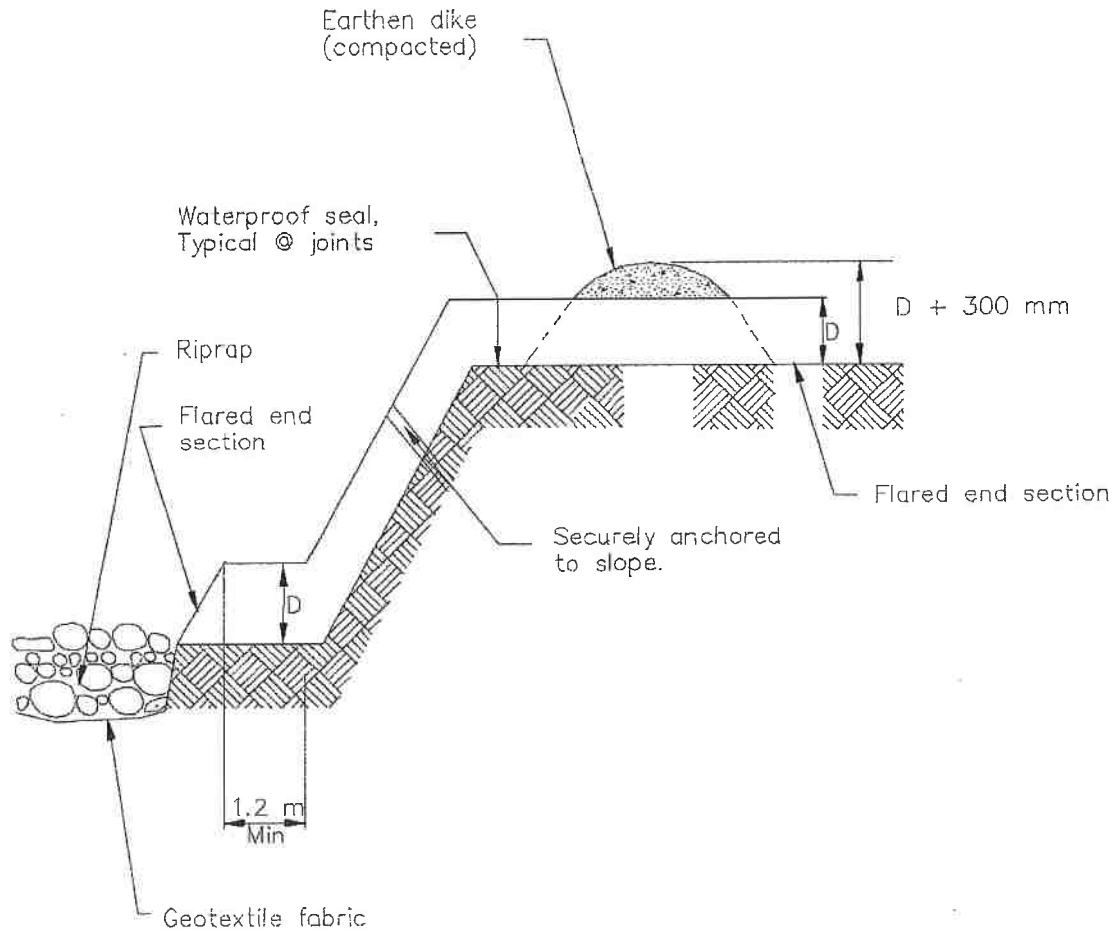

TYPICAL SLOPE DRAIN
NOT TO SCALE

Source Material for Construction BMP SS-11 Slope Drains

2003. State of California Department of Transportation. Caltrans Storm Water Quality Handbook Construction Site BMP Manual.

SC-1.1 CHECK DAMS

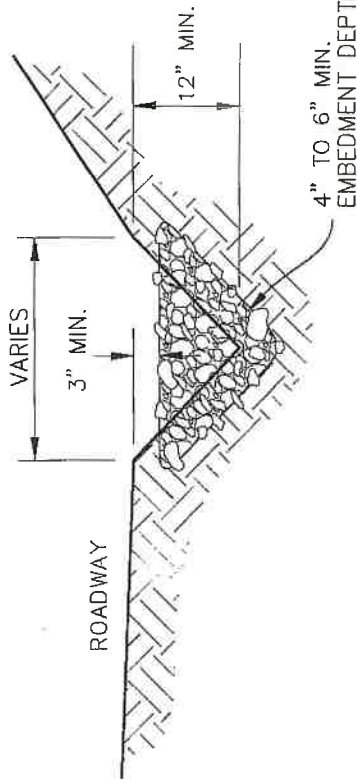

SECTION VIEW

- CHECK DAMS:**
- CHECK DAMS SHALL BE INSTALLED AT ALL LOCATIONS INDICATED ON THE WRPP, AND AT ANY OTHER LOCATION DEEMED NECESSARY BY THE SITE CONTRACTOR.
 - CHECK DAMS SHOULD BE SPACED SO THAT THE TOE OF THE CHECK DAM IS THE SAME ELEVATION AS THE TOP OF THE CHECK DAM BELOW.
 - CHECK DAMS SHOULD BE IMBEDDED IN CHANNEL A MINIMUM OF 4"-6"
 - CHECK DAMS THAT EXCEED A HEIGHT OF 3" SHOULD BE DESIGNED BY A QUALIFIED ENGINEER, GEOLOGIST, OR EROSION CONTROL SPECIALIST.
 - CHECK DAMS SHALL BE INSPECTED PERIODICALLY THROUGHOUT THE COURSE OF CONSTRUCTION, ONCE AFTER EACH RAINFALL EVENT, AND ONCE EVERY 24 HOURS DURING EXTENDED RAINFALL EVENTS. ANY SPLIT, TORN, UNRAVELED OR SLUMPING FIBER ROLLS SHALL BE REPAIRED OR REPLACED IMMEDIATELY.

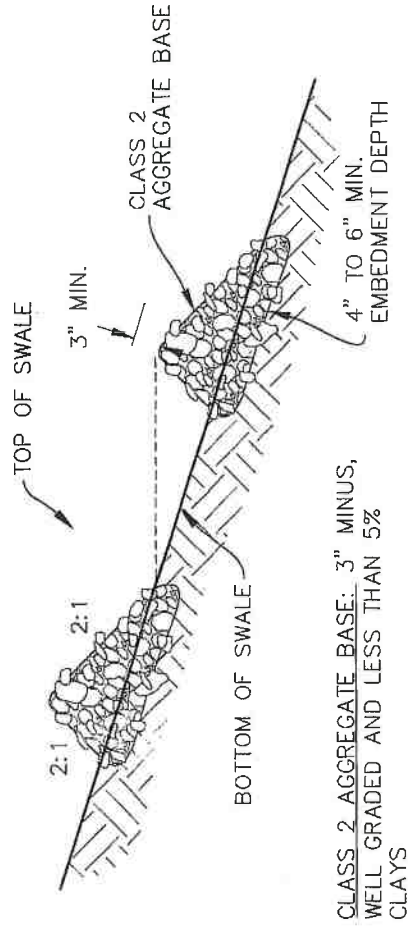

CHECK DAM SPACING

CLASS 2 AGGREGATE BASE: 3" MINUS, WELL GRADED AND LESS THAN 5% CLAYS

SC1.2 TEMPORARY SEDIMENT BASIN

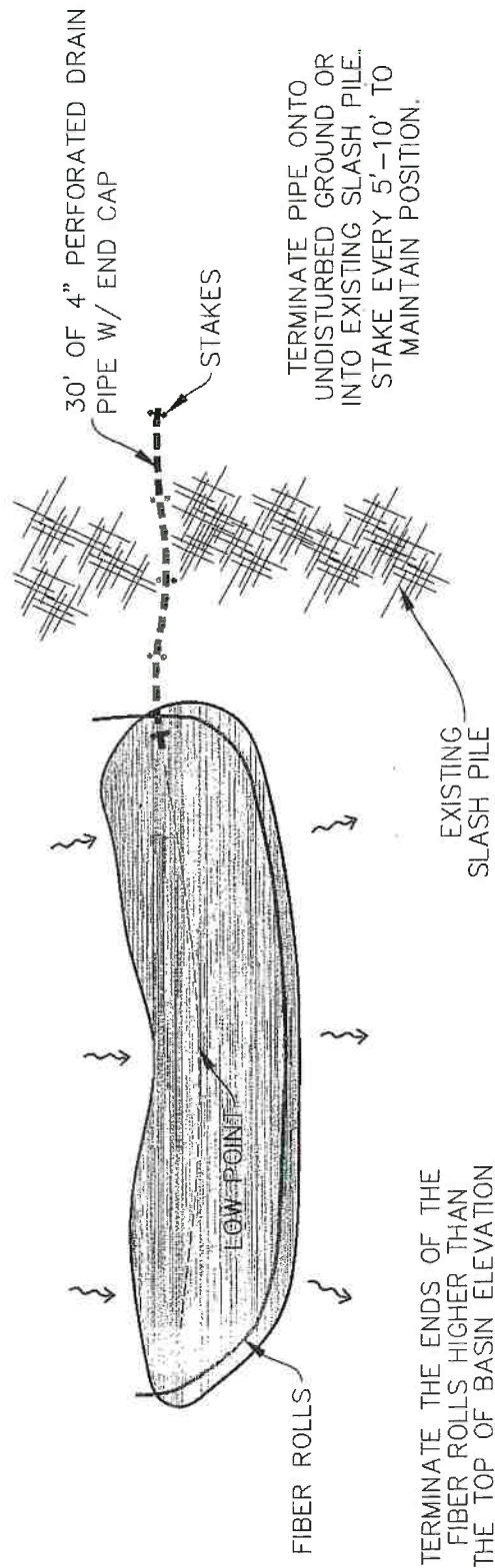

SC-1.3 FIBER ROLLS

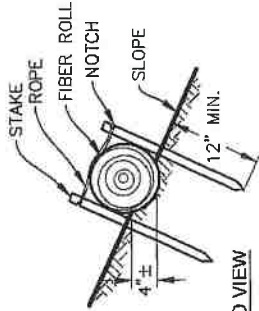

ENLARGED VIEW

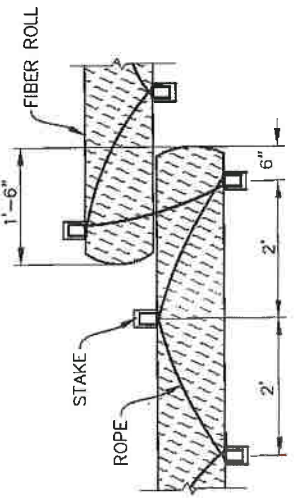
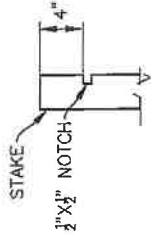

PLAN VIEW

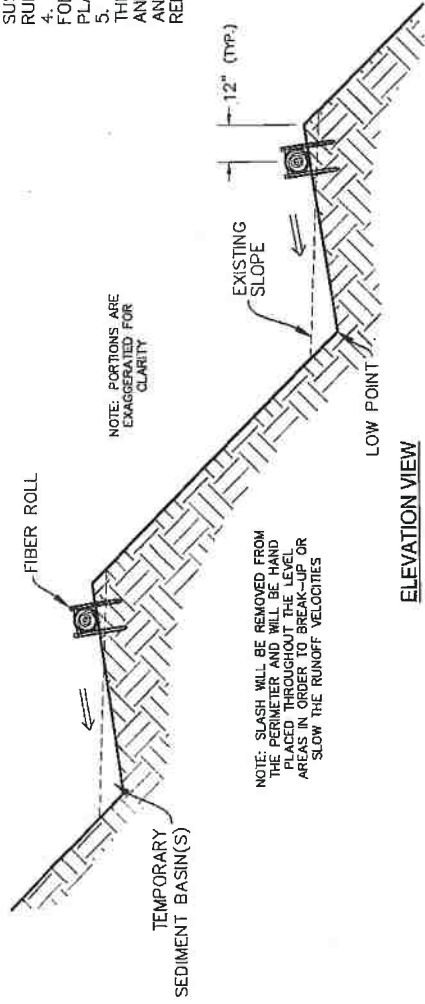

ELEVATION VIEW

FIBER ROLLS:

1. FIBER ROLLS SHALL BE INSTALLED AT ALL LOCATIONS INDICATED ON THE WRPP, AND AT ANY OTHER LOCATION DEEMED NECESSARY BY THE SITE CONTRACTOR;
2. FIBER ROLLS SHOULD BE USED ALONG THE FACE OF EXPOSED SLOPES TO SHORTEN SLOPE LENGTH AND DECREASE FLOW VELOCITY; AT GRADE BREAKS WHERE SLOPES TRANSITION TO STEEPER SLOPES; AND ALONG STREAM BANKS TO ASSIST STABILIZATION, AND IN DRAINAGE SWALES TO SLOW FLOWS. ON 1:1 SLOPES PLACE FIBER ROLLS SPACED AT 10' INTERVALS PARALLEL TO SLOPE, ON 1.5:1 SLOPES PLACE FIBER ROLLS SPACED AT 15' INTERVALS PARALLEL TO SLOPE, AND ON 2:1 SLOPES PLACE FIBER ROLLS SPACED AT 20' INTERVALS PARALLEL TO SLOPE;
3. FIBER ROLLS SHALL CONSIST OF BIODEGRADABLE FIBERS STUFFED INTO A PHOTO-DEGRADABLE OPEN WEAVE NETTING. THEY SHALL BE DESIGNED TO ALLOW WATER TO PASS THROUGH THE FIBERS; TO TRAP SUSPENDED SEDIMENT; INCREASE FILTRATION RATES; AND TO SLOW RUNOFF;
4. FIBER ROLLS SHALL BE PLACED SUCH THAT THEY OVERLAP AND FOLLOW THE CONTOUR LINES OF THE SLOPE ON WHICH THEY ARE PLACED.
5. FIBER ROLLS SHALL BE INSPECTED PERIODICALLY THROUGHOUT THE COURSE OF CONSTRUCTION, ONCE AFTER EACH RAINFALL EVENT, AND ONCE EVERY 24 HOURS DURING EXTENDED RAINFALL EVENTS. ANY SPLIT, TORN, UNRAVELED OR SLUMPING FIBER ROLLS SHALL BE REPAIRED OR REPLACED IMMEDIATELY.

NOTE: PORTIONS ARE EXAGGERATED FOR CLARITY

NOTE: SLASH WILL BE REMOVED FROM THE PERMETER AND WILL BE HAND PLACED THROUGHOUT THE LEVEL AREA TO GROUND UP OR SLOW THE RUNOFF VELOCITIES

ROAD BMP RESOURCES

DESCRIPTION

Listed below are some of the resource materials for Road BMPs that are available for landowners.

2006. California Department of Fish and Game. Part X - Upslope Erosion Inventory and Sediment Control Guidance, California Salmonid Stream Habitat Restoration Manual.

Available at:

California Department of Fish and Game
Inland Fisheries Division
ATTN: Salmonid Habitat Restoration Coordinator
1416 Ninth Street, Sacramento, CA 95814 (916) 654-5997
or
www.dfg.ca.gov/fish/resources/habitatmanual.asp

2003. California Department of Transportation (CALTRANS). Storm Water Quality Handbooks – Construction Site Best Management Practices (BMPs) Manual.

Available at:

www.dot.ca.gov/hq/construc/stormwater/CSBMPM_303_Final.pdf

2009. California Stormwater Quality Association (CASQA). California Stormwater BMP Handbook.

Available at:

California Stormwater Quality Association
PO Box 2105
Menlo Park, CA 94026
or
www.cabmphandbooks.com

2004. FishNet 4C. Guidelines for Protecting Aquatic Habitat and Salmon Fisheries for County Road Maintenance.

Available at:

3820 Cypress Dr., Suite 11
Petaluma, CA 94954 Phone: 707.762.1336
or
http://fishnet.marin.org/projects_roads_manual.html

2002. Five Counties Salmon Conservation Program. A Water Quality and Stream Habitat Protection Manual for County Road Maintenance.

Available at:

www.5counties.org/Projects/FinalGeneralProjectPages/RoadsManual800.htm

1996. US Forest Service. A Guide for Road Closure and Obliteration In the Forest Service. Technology and Development Program. Publication: 9677 1205.

Available at:

www.fs.fed.us/eng/pubs/pdfimage/96771205.pdf

2014. Weaver W.E., Wepner E. and Hagens D.K. Handbook for Forest, Ranch, and Rural Roads. Mendocino County Resource Conservation District.

Available at:

Mendocino County Resource Conservation District
404 Orchard Avenue, Ukiah, CA 95482 (707) 468-9223

Or

http://mcrd.org/wp-content/uploads/Handbook_for_Forest_Ranch&Rural_Roads.pdf



Appendix E: References

Appendix E: References

1. Humboldt County Web GIS. (2018, May). Humboldt County Planning and Building Department. Retrieved from <http://webgis.co.humboldt.ca.us/HCEGIS2.o/>
2. State of California, Department of Forestry and Fire Protection. (2018, January). *California Forest Practice Rules: Title 14, California code of regulations, chapters 4, 4.5 and 10 with the Z'Berg Nejedley Forest Practice Act, the Professional Foresters law, and the Registration of Professional Foresters Rules*. Sacramento, CA: The California Department of Forestry and Fire Protection.
3. California Natural Diversity Database (CNDDDB) Maps and Data. (2018). California Department of Fish and Wildlife. Retrieved from <https://www.wildlife.ca.gov/Data/CNDDDB/Maps-and-Data#43018408-cnddb-in-bios>
4. State of California, North Coast Regional Water Quality Control Board. (2015, August). *Order No. R1-2015-0023: Waiver of Waste Discharge Requirements and General Water Quality Certification*. Retrieved from https://www.waterboards.ca.gov/northcoast/board_decisions/adopted_orders/pdf/2015/15_0023_Cannabis_Order.pdf
5. State of California, State Water Resources Control Board. (2017, October). *Cannabis Cultivation Policy: Principles and Guidelines for Cannabis Cultivation*. Retrieved from https://www.waterboards.ca.gov/board_decisions/adopted_orders/resolutions/2017/final_cannabis_policy_with_att_a.pdf
6. State of California, State Water Resources Control Board. (2017, October). *Order No. WQ 2017-0023-DWQ: General Waste Discharge Requirements and Waiver of Waste Discharge Requirements for Discharges of Waste Associated with Cannabis Cultivation Activities*. Retrieved from https://www.waterboards.ca.gov/water_issues/programs/cannabis/docs/finaladoptedcango101717.pdf
7. State of California, California Department of Transportation, Division of Environmental Analysis, Stormwater Program. (2017, May). CTSW-RT-17-314.18.1: *Construction Site Best Management Practices (BMP) Manual*. Retrieved from <http://www.dot.ca.gov/hq/construc/stormwater/CSBMP-May-2017-Final.pdf>
8. Weaver, W.E., Weppner, E.M. and Hagans, D.K. (2015, April). *Handbook for Forest, Ranch and Rural Roads: A Guide for Planning, Designing, Constructing, Reconstructing, Upgrading, Maintaining and Closing Wildland Roads*. Ukiah, California: Mendocino County Conservation Resource District.
9. Web Soil Survey. (May, 2018). United States Department of Agriculture, Natural Resources Conservation Services. Retrieved from <https://websoilsurvey.sc.egov.usda.gov/App/WebSoilSurvey.aspx>

10. PRISM Climate Data. (May, 2018). Northwest Alliance for Computational Science and Engineering based at Oregon State University. Retrieved from <http://prism.oregonstate.edu/>
11. Google Earth V 6.2.2.6613 (May, 2018).

Appendix F: Water Use Records

Appendix F: Water Diversion, Storage, and Use

SWRCB Cannabis Cultivation Waste Discharge Regulatory Program
 Site Management Plan
 Water Diversion, Storage, and Use

Name: Lost Coast Lady farms, LLC (Marina)
 APN: 105-131-005 & 105-131-006
 Year: 2017

Total surface water diversion by source and month (gallons)

| Source | Jan | Feb | March | April | May | June | July | Aug | Sept | Oct | Nov | Dec | Total |
|--------------------|-------|-------|-------|-------|-----|------|------|-----|------|-----|-----|-----|-------|
| Point of Diversion | 3,000 | 3,500 | 0 | 0 | 0 | 0 | 0 | 0 | 0 | 0 | 0 | 0 | 6,500 |
| | | | | | | | | | | | | | |
| | | | | | | | | | | | | | |
| | | | | | | | | | | | | | |
| | | | | | | | | | | | | | 6,500 |

Water input to storage by source and month (gallons)

| Source | Jan | Feb | March | April | May | June | July | Aug | Sept | Oct | Nov | Dec | Total |
|-----------------|-------|-------|-------|-------|-----|------|------|-----|------|-----|-----|-----|-------|
| Tanks - Springs | 3,000 | 3,500 | 0 | 0 | 0 | 0 | 0 | 0 | 0 | 0 | 0 | 0 | 6,500 |
| | | | | | | | | | | | | | |
| | | | | | | | | | | | | | |
| | | | | | | | | | | | | | |
| | | | | | | | | | | | | | 6,500 |

Water use by source and month (gallons)

| Use-Source | Jan | Feb | March | April | May | June | July | Aug | Sept | Oct | Nov | Dec | Total |
|----------------------|-------|-------|-------|-------|-------|-------|--------|--------|--------|-------|-------|-------|---------|
| Domestic - Diversion | 3,300 | 3,300 | 3,300 | 3,300 | 3,300 | 3,300 | 3,500 | 3,500 | 3,300 | 3,300 | 3,300 | 3,300 | 40,000 |
| Cannabis - Diversion | - | - | - | - | 4,500 | 7,500 | 12,500 | 15,000 | 20,000 | - | - | - | 59,500 |
| Cannabis - Storage | | | | | | | | 6,500 | | | | | 6,500 |
| | | | | | | | | | | | | | |
| | | | | | | | | | | | | | 0 |
| | | | | | | | | | | | | | 106,000 |

*Note: data is an approximation and is subject to change upon further analysis.
 NorthPoint Consulting

Appendix G: Fertilizer, Pesticide, Herbicide, and Rodenticide Product List and Records

Appendix G: FERTILIZER, PESTICIDE, HERBICIDE, AND RODENTICIDE PRODUCT LIST AND RECORDS

| Type | Brand | N-P-K | Total Nitrogen (lbs) Applied* | Total Phosphorous (lbs) Applied* | |
|---------------------------------|---------------------------------|---------|-------------------------------|----------------------------------|-----------|
| Growing Medium/Soil | Greenfield's Potting Soil | N/A | - | - | |
| Fertilizer, Amendment, Additive | Azomite Micronized | 0-0-0.2 | 0 | 0 | |
| | Bat Guano - Primal Harvest | 0-11-0 | 0 | 88 | |
| | Chicken Pellets | 3-2-3 | 4.8 | 3.2 | |
| | Down to Earth Liquid Bone | 0-12-0 | 0 | 3 | |
| | Dr. Earth - Flower Girl | 1-9-2 | 10 | 90 | |
| | Pacific Pearl Oyster Shell | N/A | - | - | |
| Pesticide/Herbicide | Sparetime Supply Seaweed Powder | 1-0-18 | 0.2 | 0 | |
| | Actinovate | N/A | - | - | |
| | Diatomaceous Earth | N/A | - | - | |
| | Dr. Zyme | N/A | - | - | |
| | Green Cure | N/A | - | - | |
| | Serenade | N/A | - | - | |
| | | | | 15 lbs | 184.2 lbs |

*Applied during 2017

Appendix H: Monthly BPTC Monitoring and Maintenance Records

Appendix H: Monthly BPTC Monitoring and Maintenance Records

Monitoring Data Sheet for SWRCB Cannabis Regulatory Program
(BPTC Effectiveness Monitoring)

Inspector(s): _____ Date: _____

Owner: _____ APN: _____

Inspection Period (Circle) < Oct 15, < Dec 15, 0.5 in/day or 1 in/7 days

Other: _____

| Map Point | BPTC | *Condition: G/M/R | Comment |
|-----------|------|----------------------|---------|
| | | | |
| | | | |
| | | | |
| | | | |
| | | | |
| | | | |
| | | | |
| | | | |
| | | | |
| | | | |

* **G** - Good Condition (working as designed), **M** - Maintenance (needs maintenance to work properly), **R** - Replacement (needs to be reconstructed)

*Site Management Plan for Lost Coast Lady, LLC.
In fulfillment of the SWRCB General Waste Discharge Requirements and Waiver of Waste Discharge
Requirements for Discharges of Waste Associated with Cultivation Activities
Order WQ 2017-0023-DWQ & NCRWQCB Order No. 2015-0023*

Appendix I: Monthly pH and Turbidity Monitoring Records

Appendix I: Monthly pH and Turbidity Monitoring Records

Monitoring Data Sheet for SWRCB Cannabis Regulatory Program
(pH and Turbidity Monitoring)

Inspector(s): _____ Date: _____

Owner: _____ APN: _____

Turbidity: Conduct sampling once per month when precipitation exceeds 0.25 in./day or when stormwater is generated on site. Monitor every month until winterization procedures are complete.

pH: Conduct sampling once per month when precipitation is forecasted to exceed 0.25in./day.

| Date | Inspection Period (0.25 in./day or generation of stormwater) | Turbidity (NTU) | pH | Comments |
|------|---|--------------------|----|----------|
| | | | | |
| | | | | |
| | | | | |
| | | | | |
| | | | | |
| | | | | |
| | | | | |
| | | | | |
| | | | | |
| | | | | |

*Site Management Plan for Lost Coat Lady, LLC.
In fulfillment of the SWRCB General Waste Discharge Requirements and Waiver of Waste Discharge Requirements for Discharges of Waste Associated with Cultivation Activities
Order WQ 2017-0023-DWQ & NCRWQCB Order No. 2015-0023*

| Date | Inspection Period (0.25 in./day or generation of stormwater) | Turbidity (NTU) | pH | Comments |
|------|---|--------------------|----|----------|
| | | | | |
| | | | | |
| | | | | |
| | | | | |
| | | | | |
| | | | | |

*Site Management Plan for Lost Coat Lady, LLC.
 In fulfillment of the SWRCB General Waste Discharge Requirements and Waiver of Waste Discharge
 Requirements for Discharges of Waste Associated with Cultivation Activities
 Order WQ 2017-0023-DWQ & NCRWQCB Order No. 2015-0023*