

CHANGE ORDER

OWNER'S REPRESENTATIVE - Humboldt County Public Works • 1106 Second Street • Eureka, CA 95501 •
Ph. (707) 445-7493 Fax 445-7409

PROJECT:	HUMBOLDT COUNTY JUVENILE HALL REPLACEMENT FACILITY
	2006 Harrison Ave., Eureka, CA 95501
	Project No. 170212

SURETY: Construction Contract Takeover	WESTERN SURETY CO.
	C/O: Nancy Stangel 151 North Franklin Street, 17th Floor Chicago, IL 60606

CHANGE ORDER NO:	10
Date:	10/16/2020
Original Completion Date:	8/16/2018
Current Completion Date:	10/31/2020
Revised Completion Date:	11/03/2020
Page:	1 of 2
Cc:	

DESCRIPTION of CHANGE:

CP No.	Description	Days	Amount
112.0	Work necessary to connect the trap primers to power.	0	\$ 1,470.22
116.0	Abnormal Inclement Weather Delays.	3	\$ 0
118.1	Asbestos Abatement at Probation Building.	0	\$ 22,651.11
119.0	All work to make the necessary modifications to the penthouse design to direct water away from the penthouse as described in LOI 43.0.	0	\$ 13,513.77
120.0	Work to remove skylight and curb, and infill skylight opening at the Probation Department Roof per RFI 510.0 Response.	0	\$ 1,010.42
122.0	All work to install stainless steel data faceplates in lieu of white data faceplates to match the stainless steel electrical faceplates.	0	\$ 551.44
TOTAL		3	\$ 39,196.96

ADJUSTMENT of CONTRACT SUM

Original Contract Sum:	\$ 15,338,000.00
Prior Adjustments:	\$ 172,230.60
Contract Sum Prior to This Change:	\$ 15,510,230.60
Adjustment for This Change:	\$ 39,196.96
Revised Contract Sum:	\$ 15,549,427.56

ADJUSTMENT of CONTRACT TIME

Takeover Orig. Completion Date:	8/30/2020
Prior Adjustments (days):	62
Completion Date Prior to This Change:	10/31/2020
Adjustment for This Change (days):	3
Revised Completion Date:	11/03/2020

Western agrees to make the above-described changes in accordance with the terms hereof. This Change Order and the above-referenced amount covers and includes full compensation and all schedule impacts to Western, and to the Completion Contractor (Hal Hays Construction, Inc.) and its subcontractors, of any tier, for all costs, impacts, damages, and/or claims associated with this Change Order, including, without limitation, all claims for additional adjustments to Contract Price and Contract Time arising from or related to this Change Order. Western represents and acknowledges that it reserves no rights with respect to any costs, damages, delays, impacts, or other claims associated with or arising from this Change Order, and further, Western agrees and represents that Western, the Completion Contractor (Hal Hays Construction, Inc.) and its subcontractors, of any tier, have no other or further claims for costs, damages, delays and/or impacts arising from the changes described above that are not full resolved and released through this Change Order.

Continued on
next page

ARCHITECT

Recommended by:

Deven Carter

Digitally signed by Deven Carter
DN: C=US, E=carter@nmrdesign.com, O=NMR
Architects, CN=Deven Carter
Date: 2020.10.20 14:49:39-07'00'

Date

OWNER'S REPRESENTATIVE

Recommended by:



2021-10-18

Date

WESTERN SURETY CO.

Accepted by:

Patrick Weller

Digitally signed by Patrick Weller
DN: C=US, E=pweller@sheld.com, O=JS Held, OU=Surety,
CN=Patrick Weller
Reason: Authorized Representative
Date: 2020.10.20 11:11:45-07'00'

Date

OWNER

Approved by:

Public Works Director

Date

COST PROPOSAL 112.0



06/05/2020

TJ Glenn
Humboldt County
1106 2nd Street
Eureka, CA 95501

**Re: Humboldt County Juvenile Hall Replacement Facility
Project No. 170212**

Subject: Cost Proposal 112.0 Trap Primers

Dear TJ,

We recommend approving Cost Proposal 112.0 submitted for \$1,470.22 with no adjustment of contract time. The scope of work in the cost proposal is consistent with the direction provided in RFI response 267.0 .

Regards,

Deven Carter, Architect
Nichols, Melburg & Rossetto Architects
530-222-3300 / carter@nmrdesign.com

Department of Public Works Representative Use Only

COST PROPOSAL RESPONSE:

- Cost Proposal approved as identified above.
- Cost Proposal rejected as identified above.
- Cost Proposal approved as identified below.
- Cost Proposal rejected as identified below.

Initial: JK Date: 06/09/2020

Representative's Remarks:

COST PROPOSAL

OWNER'S REPRESENTATIVE - Humboldt County Public Works • 1106 Second Street • Eureka, CA 95501 •
Ph. (707) 445-7493 Fax 445-7409

PROJECT:	HUMBOLDT COUNTY JUVENILE HALL REPLACEMENT FACILITY 2006 Harrison Ave., Eureka, CA 95501 Project No. 170212
From:	
SURETY: Construction Contract Takeover	WESTERN SURETY CO. C/O: Nancy Stangel PO Box 5077 Sioux Falls, SD 57117-5077

COST PROPOSAL NO:	112
Date:	5/11/2020
RFCP No:	
RFI No.:	267.0
LOI No.:	
Adjustment of Contract Sum:	\$1,470.22
Adjustment of Contract Time (Calendar Days):	

SUBJECT: Trap primer power per RFI 267.0
INSTRUCTIONS:

- 1) Complete this form by providing (a) all information required above, (b) the amount and justification base on the Contract Schedule for an adjustment of Contract Time, (c) the proposed adjustment of Contract Sum.
- 2) Attach detailed cost breakdowns for all materials, wages and salaries, and fringe benefits and payroll taxes.
- 3) The Fee shall be computed on the cost of Extra Work only; and shall constitute full compensation for all costs and expenses directly and indirectly related to the subject change.

DESCRIPTION OF CHANGE: (Include justification of adjustment in Contract Time based upon the Contract Schedule)

Cost Proposal for the changed scope of work is required by the Project Architect's response to RFI 267.0, which gives direction to connect power to electronic trap primers in the Juvenile Hall building.

Surety is forwarding this proposal in its capacity as Surety and it is not assuming any obligations or liabilities beyond those set forth in the Bonds. Surety has not verified or certified any of the information contained herein

Submitted By: **Patrick Weller** Digitally signed by Patrick Weller
DN: C=US, E=pweller@jsheld.com, O=J.S. Held, CN=Patrick Weller
Reason: Authorized Representative
Date: 2020.05.12 09:16:34-07'00' **5/12/2020**
Western Surety Co. Name Date

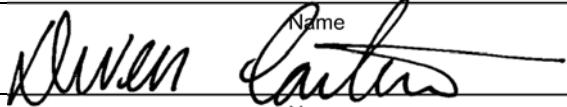
Reviewed By:  **6/5/2020**
Architect Name Date

Reviewed By: _____
Public Works Name Date



11 May 2020

Mr. Jeff Smith
Humboldt County Department of Public Works
1106 Second Street
Eureka, CA 95501

HHCI Letter No.: 16135-CP#112.0

Sent via Email:
jeff@lendersconstructionservices.com

Project: HHCI Job #16135 - Humboldt County Juvenile Hall Replacement Facility, Project #170212

Subject: Trap Primer Power per RFI 267.0

Dear Mr. Smith,

Hal Hays Construction Inc. (HHCI) is in receipt of the Architect's response to RFI 267.0 to connect power to electronic trap primers in the new Juvenile Hall building. The electrical plans do not show any power requirements for these trap primers nor does the panel schedule show any circuits for this. Our review of this request indicates that the work changes the requirements of the Contract and is a change in our scope of work. Pursuant to Specification Section 01-35-00, Modification Procedures, of our contract, this letter shall serve as our written request that a Change Order be issued for this extra work.

This change to our contract is an increase of \$1,470.22. This proposal is for acceptance within seven days and is subject to change and/or escalation thereafter.

Please reference HHCI CP#112.0 in all future correspondence regarding this matter. Please advise as soon as possible how we are to proceed. If there are any questions, please let me know.

Sincerely,

Karun Mani

Digitally signed by Karun Mani
DN: C=US, E=kmani@halhays.com,
O="Hal Hays Construction, Inc.",
OU=Operations, CN=Karun Mani
Date: 2020.05.10 13:28:57-07'00'

HAL HAYS CONSTRUCTION, INC.

Karun Mani – Major Programs Manager

Encl: Cost Proposal CP 112.0 Cover Sheet
HHCI Backup Documents
RFI 267.0 response

SUBCONTRACTOR CHANGE ORDER REQUEST FORM

SUBCONTRACTORS NAME: Valu Group Enterprises Inc.		DATE 05/06/2020	
HHCI SUBCONTRACT # 16135-47	PROJECT NAME Eureka Juvenile Hall	COR # Revised 4	
CHANGE ORDER SUBJECT Trap Primers	RFP SECTION	RFP PARAGRAPH	
CHANGE SCOPE OF WORK: (Describe RFP requirements and change; attach sketch if necessary) After Scope of Work Walk with Plumber Contractor on 05/06/2020: Connect 8 Trap Primers, supplied by plumbing contractor to nearest 120V Receptable Circuit.			
REASON FOR CHANGE: Trap Primers not shown on electrical prints nor on any panel schedule.			
PRICE BREAKDOWN:			
	Sub total	Mark up %	Total
Labor	\$ 992:00	5%	\$ 1041:60
Material	\$ 235:20		\$ 235:20
Equipment	\$ 51:25		\$ 51:25
2nd Tier Subcontractor	\$ -		\$ -
TOTALS	\$ 1278:45		\$ 1328:05
SUBMITTED BY: (SUBCONTRACTOR'S AUTHORIZED PERSONNEL) - Signature 			
*** FOR HHCI USE ONLY- COMMENTS **			
Design Build Manager: _____ (if applicable)			
Project Manager: _____			

SUBCONTRACTOR INSTRUCTIONS FOR PREPARING A CHANGE ORDER REQUEST

All Subcontract change order requests are required to be submitted to the Contractor's Representative. Requests must clearly state the conditions and scope of the change and shall be accompanied by a breakdown of cost, as indicated. Lump sum costs will not be accepted in the breakdown of direct cost. The total cost for labor, material and equipment rental for each item shall be transferred to the corresponding item on the front of this form. The Subcontractor shall not proceed with any of the work included in the change order request prior to the receipt of an executed Change Order. If Subcontractor does proceed with additional work, doing so at their own risk.

Subcontract No: 16135-47 Date: _____

BREAKDOWN OF DIRECT COSTS

SELF PERFORMED WORK	QTY	Measure of unit	MATERIAL		LABOR			EQUIPMENT		
			Unit Cost	Total Cost	Unit Cost	Fringes	Total Cost	Days	Rate	Total
Power to Trap	8	each	\$29.40	\$235.20	130.20		\$ 1041.60	1	\$51.25	\$ 51.25
Primers				\$ -			\$ -			\$ -
				\$ -			\$ -			\$ -
				\$ -			\$ -			\$ -
				\$ -			\$ -			\$ -
				\$ -			\$ -			\$ -
				\$ -			\$ -			\$ -
				\$ -			\$ -			\$ -
				\$ -			\$ -			\$ -
				\$ -			\$ -			\$ -
				\$ -			\$ -			\$ -
TOTAL-SELF PERFORMED				\$235.20			\$ 1041.60	Total		\$ 51.25
										TOTAL SELF PERFORM \$ 1328.05

2ND TIER WORK	QTY	Measure of unit	MATERIAL		LABOR			EQUIPMENT		
			Unit Cost	Total Cost	Unit Cost	Fringes	Total Cost	Days	Rate	Total
	5			\$ -			\$ -			\$ -
				\$ -			\$ -			\$ -
				\$ -			\$ -			\$ -
				\$ -			\$ -			\$ -
				\$ -			\$ -			\$ -
				\$ -			\$ -			\$ -
				\$ -			\$ -			\$ -
				\$ -			\$ -			\$ -
				\$ -			\$ -			\$ -
				\$ -			\$ -			\$ -
TOTAL-2ND TIER WORK				\$ -			\$ -	Total		\$ -
										TOTAL 2ND TIER \$ -

GRAND TOTAL \$1328.05

REQUEST FOR INFORMATION

OWNER'S REPRESENTATIVE - Humboldt County Public Works • 1106 Second Street • Eureka, CA 95501 •
Ph. (707) 445-7493 Fax 445-7409

PROJECT:	HUMBOLDT COUNTY JUVENILE HALL REPLACEMENT FACILITY
	2006 Harrison Ave., Eureka, CA 95501
	Project No. 170212
CONTRACTOR:	Hal Hays Construction, Inc.
	8850 Old Oregon Trail Redding, CA 96002
	Ph. 951-788-0703 x160
	Fx. 951-289-7112

REQUEST FOR INFORMATION NO:	267.0
Date:	02/25/20
Due Date:	03/03/20
Drawing Ref. No.:	M3.1
Specification Section:	
Cc:	

TRANSMITTAL RECORD	Date Sent	Date Rec'd.
Contractor to Project Administrator	02/25/20	02/25/20
Project Administrator to Architect / Engineer	02/25/20	
Project Admin. To DPW		

TRANSMITTAL RECORD	Date Sent	Date Rec'd.
Architect to Project Administrator	02/27/20	02/27/20
Engineer to Project Admin.		
Project Administrator to Contractor	02/28/20	

INFORMATION REQUESTED:

Per plan sheet M3.1. Plumbing contractor is to install Trap Primers in these location. Room 203,205,326,329,333, and room 601. The trap primers being install need 120 volts to operate. The trap primers are not shown on electrical prints. Please advise panel and circuit (or circuits) of power source.

Date: 02/25/2020 Signature: Shubham Goyal

REPLY:

Trap primers are a low current draw device. Connect each trap primer to the nearest 120V receptacle circuit.

Date: 02/25/2020 Signature: Ken Rubitsky Entity: LP Consulting Engineers

Information can be found in Contract Documents: Drawing Sheet No. _____ Spec. Section _____

ATTACHMENT:

--

NOTE: You are authorized to proceed with the work identified in the reply to this RFI on the assumption that no change in the Contract amount or completion date is required. If the RFI involves a change in the work affecting your contract amount or completion date, notify the Architect and Owner representative immediately.

COST PROPOSAL 116.0

COST PROPOSAL

OWNER'S REPRESENTATIVE - Humboldt County Public Works • 1106 Second Street • Eureka, CA 95501 •
Ph. (707) 445-7493 Fax 445-7409

PROJECT:	HUMBOLDT COUNTY JUVENILE HALL REPLACEMENT FACILITY 2006 Harrison Ave., Eureka, CA 95501 Project No. 170212
From:	
SURETY: Construction Contract Takeover	WESTERN SURETY CO. C/O: Nancy Stangel 151 North Franklin St, 17th Floor Chicago, IL 60606

COST PROPOSAL NO:	116
Date:	8/6/2020
RFCP No:	
RFI No.:	29.1
LOI No.:	
Adjustment of Contract Sum:	\$0.00
Adjustment of Contract Time (Calendar Days):	3 days

SUBJECT: Adverse Weather Delays**INSTRUCTIONS:**

- 1) Complete this form by providing (a) all information required above, (b) the amount and justification base on the Contract Schedule for an adjustment of Contract Time, (c) the proposed adjustment of Contract Sum.
- 2) Attach detailed cost breakdowns for all materials, wages and salaries, and fringe benefits and payroll taxes.
- 3) The Fee shall be computed on the cost of Extra Work only; and shall constitute full compensation for all costs and expenses directly and indirectly related to the subject change.

DESCRIPTION OF CHANGE: (Include justification of adjustment in Contract Time based upon the Contract Schedule)

Cost Proposal for the changed scope of work is required due to the adverse weather delays to the project per Specification Section 01-32-16, paragraph 1.5.A.20. Please see attached HHCI letter dated August 6, 2020 for further information.

Surety is forwarding this proposal in its capacity as Surety and it is not assuming any obligations or liabilities beyond those set forth in the Bonds. Surety has not verified or certified any of the information contained herein

Submitted By: Patrick Weller Digitally signed by Patrick Weller
DN: C=US, E=pweller@jsheld.com, O=JS Heki, OU=Surety, CN=Patrick Weller
Reason: Authorized Representative
Date: 2020.08.07 09:54:37-0700

Western Surety Co. _____ Name _____ Date _____

Reviewed By: _____ Name _____ Date _____

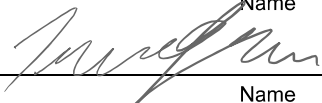
Reviewed By:  Name _____ Date 8/28/2020

Public Works _____ Name _____ Date _____



August 6 2020

Mr. Jeff Smith
 Humboldt County Department of Public Works
 1106 Second Street
 Eureka, CA 95501

HHCI Letter No.: 16135-CP # 116.0

Sent via Email
jeff@lendersconstructionservices.com

Project: #170212 HHCI Job #16135-Humboldt County Juvenile Hall Replacement Facility,

Subject: Request for Time extensions due to Adverse weather delays

Dear Mr. Smith,

The intent of this letter is to notify the county of Hal Hays Construction, Inc.'s request of **3 non-compensable calendar days** to be added to the milestone date. The following Cost Proposal listed and detailed below make up the time extension requested.

Specification Section 01-32-16, paragraph 1.5.A.20, allows for Adverse Weather Days when the precipitation exceeds 0.1 inches based on NOAA data that exceed the average number of days per month. The chart below shows the days that meet that requirement. RFI #29.0 and RFI 29.1 provided the average number of days per month with precipitation higher than 0.1 in based on NOAA data.

Date	May-20	
	Days Exceeding 0.10in of Rainfall	Additional Days Requested Total
1		
2	0.73*	
3		
4		
5		
6		
7		

8		
9		
10		
11	0.19	
12	0.38	
13		
14	0.24	
15		
16	0.47	
17	1.00	
18	0.27	
19		
20		
21		
22		
23		
24		
25		
26		
27		
28		
29		
30	1.38	
31		
Total Per Month	8	
Average Days of Precipitation (NOAA/RFI #29.1)	5	
Additional Days Requested Per Month	3	
Additional Days Requested Total		3

*Even though the precipitation event on May 2nd fell on a non-working day, since the average days of precipitation in May is taken over 31 days and work resumed on May 4th (Due to the covid-19 shutdown), HHCI is still owed 3 non-compensable days by considering it as a weighted average.

Our review of these conditions indicates that the extra work in these three items exceeds the requirements of the Contract and is a change in our scope of work. Pursuant to Specification

Section 01-35-00, Modification Procedures, of our contract, this letter shall serve as our written request that a Change Order be issued for a time extension for these items. A total extension time of Three (3) calendar days to our milestone contract completion date is requested. If there are any questions, please let me know.

Please reference HHCI COR #116.0 in all future correspondence regarding this matter. Please advise as soon as possible how we are to proceed. If there are any questions, please let me know.

Sincerely,

Karun Mani

Digitally signed by Karun Mani
DN: cn=US,
E=kmani@halhays.com, O="Hal
Hays Construction, Inc.",
OU=Operations, CN=Karun Mani
Date: 2020.06.06 15:07:22-07'00'

Karun Mani

Major Programs Manager

Hal Hays Construction Inc.

Explanation of the Preliminary Monthly Climate Data (F6) Product

These data are preliminary and have not undergone final quality control by the National Climatic Data Center (NCDC). Therefore, these data are subject to revision. Final and certified climate data can be accessed at the NCDC - <http://www.ncdc.noaa.gov>.

WFO Monthly/Daily Climate Data

000

CXUS56 KEKA 041654

CF6EKA

PRELIMINARY LOCAL CLIMATOLOGICAL DATA (WS FORM: F-6)

STATION: EUREKA CA

MONTH: MAY

YEAR: 2020

LATITUDE: 40 47 N

LONGITUDE: 124 10 W

TEMPERATURE IN F:					:PCPN:			SNOW:	WIND		:SUNSHINE:			SKY	:PK WND			
1	2	3	4	5	6A	6B	7	8	9	10	11	12	13	14	15	16	17	18
DY	MAX	MIN	AVG	DEP	HDD	CDD	WTR	SNW	DPTH	SPD	SPD	DIR	MIN	PSBL	S-S	WX	SPD	DR
1	66	43	55	3	10	0	0.00	0.0	0	5.0	14	270	M	M	5		15	M
2	65	47	56	4	9	0	0.73	0.0	0	4.5	14	270	M	M	8		22	M
3	60	43	52	-1	13	0	0.00	0.0	0	5.4	14	350	M	M	2		15	M
4	63	43	53	0	12	0	0.00	0.0	0	4.5	12	300	M	M	4		12	M
5	64	46	55	2	10	0	T	0.0	0	5.0	16	250	M	M	7		21	M
6	60	48	54	1	11	0	T	0.0	0	8.8	16	20	M	M	0		21	20
7	63	43	53	0	12	0	0.00	0.0	0	3.7	10	340	M	M	1		11	M
8	61	48	55	2	10	0	0.00	0.0	0	3.7	7	10	M	M	8	1	9	M
9	62	51	57	4	8	0	0.00	0.0	0	4.5	12	330	M	M	7	1	10	M
10	60	52	56	3	9	0	0.00	0.0	0	5.1	12	270	M	M	7		13	M
11	67	49	58	5	7	0	0.19	0.0	0	9.0	14	170	M	M	8		28	170
12	61	53	57	3	8	0	0.38	0.0	0	8.7	14	240	M	M	8		23	220
13	61	54	58	4	7	0	0.05	0.0	0	6.4	14	270	M	M	10		17	M
14	62	51	57	3	8	0	0.24	0.0	0	4.3	10	310	M	M	7		14	M
15	63	47	55	1	10	0	0.00	0.0	0	3.2	8	270	M	M	8		11	M
16	62	52	57	3	8	0	0.47	0.0	0	4.7	13	270	M	M	10		18	270
17	67	50	59	5	6	0	1.00	0.0	0	5.5	13	180	M	M	8		22	170
18	61	50	56	2	9	0	0.27	0.0	0	4.6	10	270	M	M	9		14	M
19	61	49	55	1	10	0	0.02	0.0	0	5.8	14	350	M	M	8		15	M
20	62	54	58	4	7	0	0.00	0.0	0	8.5	13	330	M	M	7		17	330
21	62	49	56	2	9	0	0.00	0.0	0	6.8	13	350	M	M	7		22	10
22	61	47	54	0	11	0	0.00	0.0	0	9.1	15	20	M	M	1		23	10
23	61	45	53	-2	12	0	0.00	0.0	0	5.3	12	350	M	M	0		18	350

24	62	50	56	1	9	0	0.00	0.0	0	4.2	10	10	M	M	2	15	M	
25	62	50	56	1	9	0	0.00	0.0	0	5.4	12	360	M	M	6	1	16	M
26	61	53	57	2	8	0	0.00	0.0	0	4.3	8	10	M	M	9	1	12	M
27	61	53	57	2	8	0	0.00	0.0	0	4.3	7	350	M	M	9	1	12	M
28	62	55	59	4	6	0	0.00	0.0	0	3.8	8	0	M	M	8	1	10	0
29	61	54	58	3	7	0	T	0.0	0	5.2	9	360	M	M	10	1	13	M
30	55	52	54	-1	11	0	1.38	0.0	0	3.0	6	330	M	M	10	13	14	M
31	61	52	57	2	8	0	0.00	0.0	0	3.7	12	360	M	M	8		13	M

```
=====
SM 1920 1533          282  0  4.73      0.0 166.0          M      202
=====
```

```
=====
AV 61.9 49.5          5.4 FASTST  M      M      7      MAX(MPH)
MISC ----> # 16 250          # 28 170
=====
```

NOTES:

LAST OF SEVERAL OCCURRENCES

COLUMN 17 PEAK WIND IN M.P.H.

PRELIMINARY LOCAL CLIMATOLOGICAL DATA (WS FORM: F-6) , PAGE 2

STATION: EUREKA CA

MONTH: MAY

YEAR: 2020

LATITUDE: 40 47 N

LONGITUDE: 124 10 W

[TEMPERATURE DATA]

[PRECIPITATION DATA]

SYMBOLS USED IN COLUMN 16

AVERAGE MONTHLY: 55.7 TOTAL FOR MONTH: 4.73
 DPTR FM NORMAL: 1.9 DPTR FM NORMAL: 2.95
 HIGHEST: 67 ON 17,11 GRTST 24HR 1.38 ON 30-30
 LOWEST: 43 ON 7, 4

SNOW, ICE PELLETS, HAIL
 TOTAL MONTH: 0.0 INCH
 GRTST 24HR 0.0
 GRTST DEPTH: 0

1 = FOG OR MIST
 2 = FOG REDUCING VISIBILITY
 TO 1/4 MILE OR LESS
 3 = THUNDER
 4 = ICE PELLETS
 5 = HAIL
 6 = FREEZING RAIN OR DRIZZLE
 7 = DUSTSTORM OR SANDSTORM:
 VSBY 1/2 MILE OR LESS
 8 = SMOKE OR HAZE
 9 = BLOWING SNOW
 X = TORNADO

[NO. OF DAYS WITH]

[WEATHER - DAYS WITH]

MAX 32 OR BELOW: 0 0.01 INCH OR MORE: 10
 MAX 90 OR ABOVE: 0 0.10 INCH OR MORE: 8
 MIN 32 OR BELOW: 0 0.50 INCH OR MORE: 3
 MIN 0 OR BELOW: 0 1.00 INCH OR MORE: 2

[HDD (BASE 65)]

TOTAL THIS MO. 282 CLEAR (SCALE 0-3) 6
 DPTR FM NORMAL -65 PTCLDY (SCALE 4-7) 15
 TOTAL FM JUL 1 3906 CLOUDY (SCALE 8-10) 10
 DPTR FM NORMAL -262

[CDD (BASE 65)]

TOTAL THIS MO. 0

DPTR FM NORMAL 0

TOTAL FM JAN 1 0

DPTR FM NORMAL 0

[PRESSURE DATA]

HIGHEST SLP 30.36 ON 6

LOWEST SLP 29.68 ON 17

[REMARKS]

#FINAL-05-20#

REQUEST FOR INFORMATION

OWNER'S REPRESENTATIVE - Humboldt County Public Works • 1106 Second Street • Eureka, CA 95501 •
Ph. (707) 445-7493 Fax 445-7409

PROJECT:	HUMBOLDT COUNTY JUVENILE HALL REPLACEMENT FACILITY
	2006 Harrison Ave., Eureka, CA 95501
	Project No. 170212
CONTRACTOR:	Hal Hays Construction, Inc.
	8850 Old Oregon Trail Redding, CA 96002
	Ph. 951-788-0703 x160
	Fx. 951-289-7112

REQUEST FOR INFORMATION NO:	29.1
Date:	08/16/17
Due Date:	08/18/17
Drawing Ref. No.:	
Specification Section:	01-32-16
Cc:	

TRANSMITTAL RECORD	Date Sent	Date Rec'd.
Contractor to Project Administrator	08/16/17	08/16/17
Project Administrator to Architect / Engineer		
Project Admin. To DPW		

TRANSMITTAL RECORD	Date Sent	Date Rec'd.
Architect to Project Administrator		
Engineer to Project Admin.		
Project Administrator to Contractor	09/13/17	

INFORMATION REQUESTED:

Per specification section 01 32 16 paragraph 1.5A 20, the adverse weather days anticipated each month shall be based on historical information from NOAA data. We have contacted NOAA to get this information but they were unable to provide it. Please advise.

Date: 08/16/2017 Signature: Jay Mulligan

REPLY:

Supplemental Information:
See attached data from the NOAA

Date: 09/13/2017 Signature: Jeff Smith Entity: LCS

Information can be found in Contract Documents: Drawing Sheet No. _____ Spec. Section _____

ATTACHMENT:

Att #1 - AVERAGE PRECIPITATION DAYS DATA - NOAA

NOTE: You are authorized to proceed with the work identified in the reply to this RFI on the assumption that no change in the Contract amount or completion date is required. If the RFI involves a change in the work affecting your contract amount or completion date, notify the Architect and Owner representative immediately.

AVERAGE PRECIPITATION DAYS DATA - NOAA
EUREKA, CA 1886-2006
Days with 0.10 inch or more of Rainfall

Month	JAN	FEB	MAR	APR	MAY	JUN	JUL	AUG	SEP	OCT	NOV	DEC	ANNUAL
Avg Days of Precipitation	12	10	10	7	5	2	0	1	2	5	9	11	75

COST PROPOSAL 118.1



08/18/2020

TJ Glenn
Humboldt County
1106 2nd Street
Eureka, CA 95501

**Re: Humboldt County Juvenile Hall Replacement Facility
Project No. 170212**

Subject: Cost Proposal 118.1 Haz Mat Abatement

Dear TJ,

We recommend approving Cost Proposal 118.1 submitted for \$22,651.11, with no adjustment of contract time. The required back-up for adjustment of contract time is not provided in the proposal. The scope of work in the cost proposal is consistent with the direction provided by the County.

Regards,

Deven Carter, Architect
Nichols, Melburg & Rossetto Architects
530-222-3300 / carter@nmrdesign.com

Department of Public Works Representative Use Only

COST PROPOSAL RESPONSE:

- Cost Proposal approved as identified above.
- Cost Proposal rejected as identified above.
- Cost Proposal approved as identified below.
- Cost Proposal rejected as identified below.

Initial: JR Date: 8/19/2020

Representative's Remarks:

COST PROPOSAL

OWNER'S REPRESENTATIVE - Humboldt County Public Works • 1106 Second Street • Eureka, CA 95501 •
Ph. (707) 445-7493 Fax 445-7409

PROJECT:	HUMBOLDT COUNTY JUVENILE HALL REPLACEMENT FACILITY 2006 Harrison Ave., Eureka, CA 95501 Project No. 170212
From:	
SURETY: Construction Contract Takeover	WESTERN SURETY CO. C/O: Nancy Stangel 151 North Franklin St, 17 th Floor Chicago, IL 60606

COST PROPOSAL NO:	118.1
Date:	8/6/2020
RFCP No:	
RFI No.:	
LOI No.:	
Adjustment of Contract Sum:	\$22,651.11
Adjustment of Contract Time (Calendar Days):	TBD

SUBJECT: Probation Building Asbestos Abatement

INSTRUCTIONS:

- 1) Complete this form by providing (a) all information required above, (b) the amount and justification base on the Contract Schedule for an adjustment of Contract Time, (c) the proposed adjustment of Contract Sum.
- 2) Attach detailed cost breakdowns for all materials, wages and salaries, and fringe benefits and payroll taxes.
- 3) The Fee shall be computed on the cost of Extra Work only; and shall constitute full compensation for all costs and expenses directly and indirectly related to the subject change.

DESCRIPTION OF CHANGE: (Include justification of adjustment in Contract Time based upon the Contract Schedule)

Cost Proposal for the changed scope of work is required by asbestos abatement work per walk through with County on July 29, 2020. The changes included in this cost proposal are for asbestos abatement including, but not limited to:

1. Skylights in rooms 207 & 209; exterior stucco outside Lobby 217 & rooms 218, 210, 205 & south-west stairwell; 2 pipe elbows (1 each in corridor 105 & outside room 212)
2. Abatement of drywall with rubber base mastic in rooms 210, 211, 220, 221, 225, 231 & 218

Please note that this Cost Proposal only covers asbestos abatement for already exposed and known areas of abatement in the Probation Building, excluding Rooms 208, 204, 203 and 113. This proposal does not cover any additional abatement that might be required based on response to RFI 511 Flooring demo. Additionally, Western/HHCI is not responsible for any additional abatement for unknown locations that might need to be abated which are not included below. This Cost Proposal also does not include any testing fees or air sampling costs. Lead paint abatement is also excluded.

~~Western/HHCI reserves all rights to supplement CP 118.1 with a corresponding Time Impact Analysis (TIA) for any/all delays arising due to this change in scope.~~ REFER TO SPECIFICATIONS SECTION 01 32 16

Surety is forwarding this proposal in its capacity as Surety and it is not assuming any obligations or liabilities beyond those set forth in the Bonds. Surety has not verified or certified any of the information contained herein

Submitted By: Patrick Weller Name: Patrick Weller Date: 2020.08.07 09:58:31-07'00'
Western Surety Co. Name: Deven Carter Date: 2020.08.18 10:08:38-07'00'

Reviewed By: Deven Carter Name: Deven Carter Date: 2020.08.18 10:08:38-07'00'

Architect

Name

Date

Reviewed By:
Public Works

[Handwritten Signature]
Name

8/19/2020
Date



6 August 2020

Mr. Jeff Smith
Humboldt County Department of Public Works
1106 Second Street
Eureka, CA 95501

HHCI Letter No.: 16135-CP#118.1

Sent via Email:
jeff@lendersconstructionservices.com

Project: HHCI Job #16135 - Humboldt County Juvenile Hall Replacement Facility, Project #170212

Subject: Probation Building Asbestos Abatement

Dear Mr. Smith,

Hal Hays Construction Inc. (HHCI) is hereby submitting Cost Proposal 118.1 for asbestos abatement as pointed out by the County's Hazmat consultant Zindar Brunelle during a walk through with HHCI and the County on July 29, 2020. Please note that this Cost Proposal only covers asbestos abatement for already exposed and known areas of abatement in the Probation Building, excluding Rooms 208, 204, 203 and 113. This proposal does not cover any additional abatement that might be required based on response to RFI 511 Flooring demo. Additionally, HHCI is not responsible for any additional abatement for unknown locations that might need to be abated which are not included below. This Cost Proposal also does not include any testing fees or air sampling costs. Lead paint abatement is also excluded.

The abatement included in this Cost Proposal 118.1 is including but not limited to the below:

1. Skylights in rooms 207 & 209; exterior stucco outside Lobby 217 & rooms 218, 210, 205 & south-west stairwell; 2 pipe elbows (1 each in corridor 105 & outside room 212)
2. Abatement of drywall with rubber base mastic in rooms 210, 211, 220, 221, 225, 231 & 218

This change to our contract is an increase of \$22,651.11. This proposal is for acceptance within seven days and is subject to change and/or escalation thereafter.

HHCI also reserves all rights to supplement CP 118.1 with a corresponding Time Impact Analysis (TIA) for any/all delays arising due to this change in scope.

Please reference HHCI CP#118.1 in all future correspondence regarding this matter. Please advise as soon as possible how we are to proceed. If there are any questions, please let me know.

6 August 2020
Page 2 of 2

Sincerely,



HAL HAYS CONSTRUCTION, INC.
Karun Mani – Major Programs Manager

Encl: Cost Proposal CP 118.1 Cover Sheet
HHCI Backup Documents

Infinity Abatement Services

19215 Snowburst Ct. Redding Ca. 96003
Phone (530)605-8850 Fax (530)222-8080
Calif. License #883918 DOSH #100 DIR#10000032461



Proposal

To: Hal Hays Construction Inc.

Reference: Humboldt Probation Additional Work COR #3- 1st and 2nd floors Probation Administration Offices

Infinity Abatement Services will remove and dispose of the following materials from Misc. materials Identified need for abatement-

- Remove and dispose of all Sheetrock materials/trim from the Interior well of Skylights in rooms 108/109 (\$1750.00)
- Remove and dispose of Exterior Overhang Stucco from the Main entryway (approx.. 115 sq ft)
- Remove and dispose of Exterior Overhang Stucco from from the East side where meets Juvenile Hall building (approx. 40 sq ft)
- Remove and dispose of Exterior Overhang Stucco from the West side at 2 separate areas (approx.. 40 sq ft and 120 sq ft each)
- Remove 2 TSI elbows as needed in Admin offices hallway (\$350.00)

Labor- \$13,920.00

(Travel, lodging, work comp., Prevailing asbestos wages, work comp, bid quote)

Materials and equipment, rental- \$4010.00

(All abatement materials i.e., bags, rags, plastic sheeting, respirators, cleaning supplies, filters, personal air samples, bags, PPE, Tape, Portable shower, neg air machines, vacuums, truck, gas to haul materials/equipment to and from Redding, Scissor Lift rental, delivery and Pick up))

Disposal costs/Hauling of all Asbestos wastes to be disposed at Anderson Landfill \$1720.00

Labor-\$13,920.00

Materials and Equipment-\$4,010.00

Waste disposal fees- \$1,720.00

Price \$19,650.00

*Price includes Asbestos prevailing wage rates, disposal, notification, insurance, and personal air sampling.

*All workers will have current Medical exam and asbestos/lead training.

*All local, state and federal laws will be followed

*Owner to supply power and water

* Includes EPA and OSHA notifications and fees

*Exclusions- final/area air sampling, replacement of materials removed, possible duct tape damage to wall surfaces.

Joe Nixt

Owner

7/30/2020

Infinity Abatement Services

19215 Snowburst Ct. Redding Ca. 96003
Phone (530)605-8850 Fax (530)222-8080
Calif. License #883918 DOSH #100 DIR#10000032461



Proposal

To: Hal Hays Construction Inc.

Reference: Humboldt Probation Clean Up 1st and 2nd floors
probation Administration Offices

Infinity Abatement Services will visually clean all rooms and items of dusts on the 1st and 2nd floors of the Main Admin building to include the South/West Stairway. Cleaning will be done using Misc. containments so as to accommodate ongoing construction work. Work being performed due to misc. asbestos containing construction materials were removed without containments.

IAS will remove the remaining baseboard mastics on the West walls as needed and square up any Sheetrock that was disturbed as needed for others to replace properly.

Labor- \$25,950.00

(Travel, lodging, work comp., Prevailing asbestos wages, work comp, bid quote)

Materials and equipment- \$2,960.00

(All abatement materials i.e., bags, rags, plastic sheeting, respirators, cleaning supplies, filters, personal air samples, bags,

PPE, Tape, Portable shower, neg air machines, vacuums, truck, gas to haul materials/equipment to and from Redding)

Disposal costs/Hauling of all Asbestos wastes to be disposed at Anderson Landfill \$1640.00

Labor-\$25,950.00

Materials and Equipment-\$2960.00

Waste disposal fees- \$1640.00

Price ~~\$30,550.00~~ \$3,000 (only for abatement for floor mastic in rooms called out for on the 2nd floor)

*Price includes Asbestos prevailing wage rates, disposal, notification, insurance, and personal air sampling.

*All workers will have current Medical exam and asbestos/lead training.

*All local, state and federal laws will be followed

*Owner to supply power and water

* Includes EPA and OSHA notifications and fees

*Exclusions- final/area air sampling, replacement of materials removed, possible duct tape damage to wall surfaces.

Joe Nixt

Owner

7/30/2020

COST PROPOSAL 119.0



08/11/2020

TJ Glenn
Humboldt County
1106 2nd Street
Eureka, CA 95501

**Re: Humboldt County Juvenile Hall Replacement Facility
Project No. 170212**

Subject: Cost Proposal 119.0 - Wing walls at Penthouse

Dear TJ,

We recommend approving Cost Proposal 119.0 submitted for \$13,513.77 with no adjustment of contract time. The scope of work in the cost proposal is consistent with the direction provided in LOI 43.0.

Regards,

Deven Carter, Architect
Nichols, Melburg & Rossetto Architects
530-222-3300 / carter@nmrdesign.com

Department of Public Works Representative Use Only

COST PROPOSAL RESPONSE:

- Cost Proposal approved as identified above.
- Cost Proposal rejected as identified above.
- Cost Proposal approved as identified below.
- Cost Proposal rejected as identified below.

Initial: DC Date: 08/18/2020

Representative's Remarks:

COST PROPOSAL

OWNER'S REPRESENTATIVE - Humboldt County Public Works • 1106 Second Street • Eureka, CA 95501 •
Ph. (707) 445-7493 Fax 445-7409

PROJECT:	HUMBOLDT COUNTY JUVENILE HALL REPLACEMENT FACILITY 2006 Harrison Ave., Eureka, CA 95501 Project No. 170212
From:	
SURETY: Construction Contract Takeover	WESTERN SURETY CO. C/O: Nancy Stangel 151 North Franklin St, 17 th Floor Chicago, IL 60606

COST PROPOSAL NO:	119.0
Date:	8/6/2020
RFCP No:	
RFI No.:	
LOI No.:	
Adjustment of Contract Sum:	\$13,513.77
Adjustment of Contract Time (Calendar Days):	0

SUBJECT: LOI 43 Roof Changes**INSTRUCTIONS:**

- 1) Complete this form by providing (a) all information required above, (b) the amount and justification base on the Contract Schedule for an adjustment of Contract Time, (c) the proposed adjustment of Contract Sum.
- 2) Attach detailed cost breakdowns for all materials, wages and salaries, and fringe benefits and payroll taxes.
- 3) The Fee shall be computed on the cost of Extra Work only; and shall constitute full compensation for all costs and expenses directly and indirectly related to the subject change.

DESCRIPTION OF CHANGE: (Include justification of adjustment in Contract Time based upon the Contract Schedule)

Cost Proposal for the changed scope of work is required by the LOI 43 Roof Changes. The changes included in this cost proposal are including, but not limited to:

1. Add wing walls in Penthouse 3
2. Frame curbs in Penthouse 1A and 3.

Surety is forwarding this proposal in its capacity as Surety and it is not assuming any obligations or liabilities beyond those set forth in the Bonds. Surety has not verified or certified any of the information contained herein

Submitted By: Patrick Weller Digitally signed by Patrick Weller
DN: C=US, E=pweller@sheld.com, O=JS Held, OU=Surety, CN=Patrick Weller
Reason: Authorized Representative
Date: 2020.08.07 10:05:27-0700

Western Surety Co. Name _____ Date _____

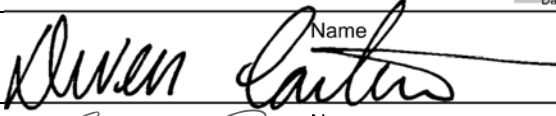
Reviewed By:  Name _____ Date 8/11/2020

Architect Name _____ Date _____

Reviewed By:  Name _____ Date 08/18/2020

Public Works Name _____ Date _____



6 August 2020

Mr. Jeff Smith
Humboldt County Department of Public Works
1106 Second Street
Eureka, CA 95501

HHCI Letter No.: 16135-CP#119.0

Sent via Email:
jeff@lendersconstructionservices.com

Project: HHCI Job #16135 - Humboldt County Juvenile Hall Replacement Facility, Project #170212

Subject: LOI 43 Roof Changes

Dear Mr. Smith,

Hal Hays Construction Inc. (HHCI) is in receipt of LOI 43 Roof Changes. Our review of this response indicates that the work changes the requirements of the Contract and is a change in our scope of work. Pursuant to Specification Section 01-35-00, Modification Procedures, of our contract, this letter shall serve as our written request that a Change Order be issued for this extra work.

The changes on LOI 43 and our CP 119.0 includes, but is not limited to the below:

1. Add wing walls in Penthouse 3.
2. Frame curbs for Penthouse 1A and 3.

This change to our contract is an increase of \$13,513.77. This proposal is for acceptance within seven days and is subject to change and/or escalation thereafter.

Please reference HHCI CP#119.0 in all future correspondence regarding this matter. Please advise as soon as possible how we are to proceed. If there are any questions, please let me know.

Sincerely,

Karun Mani

Digitally signed by Karun Mani
DN: C=US,
E=kmani@halhays.com, O="Hal
Hays Construction, Inc.",
OU=Operations, CN=Karun Mani
Date: 2020.08.06 18:47:21-07'00'

HAL HAYS CONSTRUCTION, INC.
Karun Mani – Major Programs Manager

Encl: Cost Proposal CP 119.0 Cover Sheet
HHCI Backup Documents



865 Commerce St. Suite #1
 Redding, CA. 96002
 530-605-3017
 dcrain@dc-builder.net
 Lic # 885397

CLIENT		Estimate	
Hal Hays Construction Inc 4181 Lathem Street Riverside, CA 92501		Date	8/4/2020
		Estimate #	312709
		Project	Frame/ Drywall
Item	Description	Total	
WORK SCOPE	<p>-Construct 25.88 sqft of steel stud wall for outside roof Penthouse on new Juvenile Detention Center building</p> <p>-Construct 55.55 sqft of steel stud curb for outside roof Penthouse on new Juvenile Detention Center building</p> <p>-Install 325.72 sqft of DensShield panels with only a tape joint and skim coat on all seams for outside roof Penthouse on new Juvenile Detention Center building</p> <p>Additional Notes:</p> <p>DC Construction is only responsible for the debris created by our company. DC Construction is not responsible for any demo clean up done by others. All additional work beyond scope said within this proposal will be subject to what is called a "Change Order" and will signed as an agreement prior to work being commenced. General contractor is responsible for calling for inspections needed to sign off on work.</p>	8,888.66	
<i>Estimate is valid for 30 days</i>		Total	\$8,888.66
ACCEPTANCE (Signature)		Date	

ARK DESIGN CONSTRUCTION & ROOFING INC.

STATE LICENSE #632117

Attachment: Change Order #10

P.O. BOX 868
 PALO CEDRO, CA 96073
 Phone (530) 547-3890 Fax (530) 547-4170

TO: Hal Hays Construction, Inc.
4181 Latham St.
Riverside, CA 92501

PHONE	FAX	Email	Date
(951) 788-0703			8/5/2020
CONTRACT OR PROPOSAL NUMBER (IF ANY)			Subcontract # 16135-41
JOB NAME AND LOCATION			
Humboldt County Juvenile Hall 2002 Harrison Ave. Eureka, CA			

We hereby agree to the following change(s) or additional work specified below:

Change Order #3
 Install Metal Wall Panel On 2 Wing Walls To Penthouse # 3

Labor	\$2,000.00
Materials	\$1,000.00
P&O 15%	\$450.00
Total	\$3,450.00

NOTE: This change Order becomes part of and in conformance with the existing contract:

WE AGREE hereby to make the change(s) specified above at this price:	\$3,450.00
--	------------

Date of agreement	8/5/2020	Previous Contract Amount:	
-------------------	----------	---------------------------	--

Authorized Signature		Revised Contract Total:	
----------------------	--	-------------------------	--

(CONTRACTOR OR AGENT)

ACCEPTED-The above prices and specifications of this change order are hereby accepted. All all work to be performed under the same terms in the original contract unless otherwise stipulated.

Authorized Signature	
OWNER OR AGENT	
Date Accepted	

LETTER of INSTRUCTION

OWNER'S REPRESENTATIVE - Humboldt County Public Works • 1106 Second Street • Eureka, CA 95501 •
Ph. (707) 445-7493 Fax 445-7409

PROJECT:	HUMBOLDT COUNTY JUVENILE HALL REPLACEMENT FACILITY	LETTER of INSTRUCTION NO:	43.0
	2006 Harrison Ave., Eureka, CA 95501	Due Date:	
	Project No. 170212	Date:	2/3/2020
TO:		RFI No:	
CONTRACTOR:	Hal Hays Construction, Inc.	Cc:	
	8850 Old Oregon Trail Redding, CA 96002		
	Ph. 951-788-0703 x160		
	Fx. 951-289-7112		

SUBJECT: WINDOW SILL

The following is an interpretation or clarification of the Contract Documents. It is consistent with the Contract Documents. This Letter of Instruction authorizes no change in the contract amount or completion date.

INTERPRETATION or CLARIFICATION:

41.0-1

Refer to drawing A131, "LOW ROOF PLAN." Add walls, curbs and scuppers at Penthouse 3 as indicated on the attached sketch.

41.0-2

Refer to drawing A131, "LOW ROOF PLAN." Add curbs and scuppers at Penthouse 1A as indicated on the attached sketch.

41.0-3

Refer to drawing A131, "LOW ROOF PLAN," Reduce clearance between mechanical equipment in penthouse 3.

Purpose of this LOI:

1. To adjust the penthouse design to direct rain water from the penthouse as requested by the County.
2. To clarify the minimum allowable distance between the package units in penthouse 3 as requested by the Contractor.

ATTACHMENT:

sk 42.0-1,

Issued By: Deven Carter Project Architect 2/3/2020
Name Title Date



COST PROPOSAL 120.0



08/14/2020

TJ Glenn
Humboldt County
1106 2nd Street
Eureka, CA 95501

**Re: Humboldt County Juvenile Hall Replacement Facility
Project No. 170212**

Subject: Cost Proposal 120.0 - Probation Infill

Dear TJ,

We recommend approving Cost Proposal 120.0 submitted for \$1,010.42 with no adjustment of contract time. The scope of work in the cost proposal is consistent with the direction provided in RFI response 510.

Regards,

Deven Carter, Architect
Nichols, Melburg & Rossetto Architects
530-222-3300 / carter@nmrdesign.com

Department of Public Works Representative Use Only

COST PROPOSAL RESPONSE:

- Cost Proposal approved as identified above.
- Cost Proposal rejected as identified above.
- Cost Proposal approved as identified below.
- Cost Proposal rejected as identified below.

Initial: VG Date: 08/25/2020

Representative's Remarks:

COST PROPOSAL

OWNER'S REPRESENTATIVE - Humboldt County Public Works • 1106 Second Street • Eureka, CA 95501 •
Ph. (707) 445-7493 Fax 445-7409

PROJECT:	HUMBOLDT COUNTY JUVENILE HALL REPLACEMENT FACILITY 2006 Harrison Ave., Eureka, CA 95501 Project No. 170212
From:	
SURETY: Construction Contract Takeover	WESTERN SURETY CO. C/O: Nancy Stangel 151 North Franklin St, 17 th Floor Chicago, IL 60606

COST PROPOSAL NO:	120.0
Date:	8/13/2020
RFCP No:	
RFI No.:	510
LOI No.:	
Adjustment of Contract Sum:	\$1,010.42
Adjustment of Contract Time (Calendar Days):	0

SUBJECT: Probation Building Skylight Infill per RFI 510**INSTRUCTIONS:**

- 1) Complete this form by providing (a) all information required above, (b) the amount and justification base on the Contract Schedule for an adjustment of Contract Time, (c) the proposed adjustment of Contract Sum.
- 2) Attach detailed cost breakdowns for all materials, wages and salaries, and fringe benefits and payroll taxes.
- 3) The Fee shall be computed on the cost of Extra Work only; and shall constitute full compensation for all costs and expenses directly and indirectly related to the subject change.

DESCRIPTION OF CHANGE: (Include justification of adjustment in Contract Time based upon the Contract Schedule)

Cost Proposal for the changed scope of work is required by the RFI 510. The changes included in this cost proposal are including, but not limited to:

1. Infill skylight openings in roof in Rooms 207 and 209.

Surety is forwarding this proposal in its capacity as Surety and it is not assuming any obligations or liabilities beyond those set forth in the Bonds. Surety has not verified or certified any of the information contained herein

Submitted By: _____	Patrick Weller	<small>Digitally signed by Patrick Weller DN: C=US, E=pweller@sheld.com, O=JS Held, OU=Surety, CN=Patrick Weller Reason: Authorized Representative Date: 2020.08.13 12:07:28-07'00'</small>
Western Surety Co.	Name	Date
Reviewed By: _____	Deven Carter	<small>Digitally signed by Deven Carter DN: C=US, E=carter@nmrdesign.com, O=NMR Architects, CN=Deven Carter Date: 2020.08.14 14:35:59-07'00'</small>
Architect	Name	Date
Reviewed By: _____		08/25/2020
Public Works	Name	Date



13 August 2020

Mr. Jeff Smith
Humboldt County Department of Public Works
1106 Second Street
Eureka, CA 95501

HHCI Letter No.: 16135-CP#120.0

Sent via Email:
jeff@lendersconstructionservices.com

Project: HHCI Job #16135 - Humboldt County Juvenile Hall Replacement Facility, Project #170212

Subject: Infill Skylights in Probation Building per RFI 510.0

Dear Mr. Smith,

Hal Hays Construction Inc. (HHCI) is in receipt of RFI 510 Probation Building Skylights. Our review of this response indicates that the work changes the requirements of the Contract and is a change in our scope of work. Pursuant to Specification Section 01-35-00, Modification Procedures, of our contract, this letter shall serve as our written request that a Change Order be issued for this extra work.

The changes on per CP 120.0 includes, but is not limited to the below:

1. Infill roof skylight opening in Rooms 207 and 209.

This change to our contract is an increase of \$1,010.42. This proposal is for acceptance within seven days and is subject to change and/or escalation thereafter.

Please reference HHCI CP#120.0 in all future correspondence regarding this matter. Please advise as soon as possible how we are to proceed. If there are any questions, please let me know.

Sincerely,

Karun Mani
Digitally signed by Karun Mani
DN: C=US,
E=kmani@halhays.com, O="Hal
Hays Construction, Inc.",
OU=Operations, CN=Karun Mani
Date: 2020.08.13 11:54:34-07'00'

HAL HAYS CONSTRUCTION, INC.
Karun Mani – Major Programs Manager

Encl: Cost Proposal CP 120.0 Cover Sheet
HHCI Backup Documents



865 Commerce St. Suite #1
 Redding, CA. 96002
 530-605-3017
 dcrain@dc-builder.net
 Lic # 885397

CLIENT		Estimate	
Hal Hays Construction Inc 4181 Lathem Street Riverside, CA 92501		Date	8/6/2020
		Estimate #	312711
		Project	Skylights
Item	Description	Total	
WORK SCOPE	Remove 2 existing skylights from roof and dispose, in-fill opening with new rafters and hangers to support new roof materials. Refer to RFI 510.0 dated 07/09/2020	922.56	
<i>Estimate is valid for 30 days</i>		Total	\$922.56
ACCEPTANCE (Signature)		Date	

REQUEST FOR INFORMATION

OWNER'S REPRESENTATIVE - Humboldt County Public Works • 1106 Second Street • Eureka, CA 95501 •
Ph. (707) 445-7493 Fax 445-7409

PROJECT:	HUMBOLDT COUNTY JUVENILE HALL REPLACEMENT FACILITY
	2006 Harrison Ave., Eureka, CA 95501
	Project No. 170212
CONTRACTOR:	Hal Hays Construction, Inc.
	8850 Old Oregon Trail Redding, CA 96002
	Ph. 951-788-0703 x160
	Fx. 951-289-7112

REQUEST FOR INFORMATION NO:	510.0
Date:	07/09/20
Due Date:	07/16/20
Drawing Ref. No.:	B-M2.2
Specification Section:	
Cc:	

TRANSMITTAL RECORD	Date Sent	Date Rec'd.
Contractor to Project Administrator	07/09/20	07/09/20
Project Administrator to Architect / Engineer	07/09/20	
Project Admin. To DPW		

TRANSMITTAL RECORD	Date Sent	Date Rec'd.
Architect to Project Administrator	07/16/20	
Engineer to Project Admin.		
Project Administrator to Contractor	07/17/20	

INFORMATION REQUESTED:

There is one skylight each in room P207 & P209 which are not shown on Plans. Both these skylights are in conflict with the new HVAC ducting as shown on B-M2.2 Please advise if these skylights are to be removed & Please advise if they have to be covered with plywood sheathing on top of the roof. Also, please advise if any lighting requirements are needed for room P207 & P209

Date: 07/09/2020 Signature: Pavan Nanikalva

REPLY:

Remove skylight and curb at roof. Infill opening at roof. Existing lighting and switching in room P207 and room P209 to remain.

Date: 07/16/2020 Signature: Deven Carter Entity: NMR Architects

Information can be found in Contract Documents: Drawing Sheet No. _____ Spec. Section _____

ATTACHMENT:

--

NOTE: You are authorized to proceed with the work identified in the reply to this RFI on the assumption that no change in the Contract amount or completion date is required. If the RFI involves a change in the work affecting your contract amount or completion date, notify the Architect and Owner representative immediately.

COST PROPOSAL 122.0



08/14/2020

TJ Glenn
Humboldt County
1106 2nd Street
Eureka, CA 95501

**Re: Humboldt County Juvenile Hall Replacement Facility
Project No. 170212**

Subject: Cost Proposal 122.0 – Stainless Faceplates

Dear TJ,

We recommend approving Cost Proposal 122.0 submitted for \$551.44 with no adjustment of contract time. The scope of work in the cost proposal is consistent with the County's request for stainless steel data faceplates to match the stainless steel electrical faceplates.

Regards,

Deven Carter, Architect
Nichols, Melburg & Rossetto Architects
530-222-3300 / carter@nmrdesign.com

Department of Public Works Representative Use Only

COST PROPOSAL RESPONSE:

- Cost Proposal approved as identified above.
- Cost Proposal rejected as identified above.
- Cost Proposal approved as identified below.
- Cost Proposal rejected as identified below.

Initial: JG Date: 08/29/2020

Representative's Remarks:

COST PROPOSAL

OWNER'S REPRESENTATIVE - Humboldt County Public Works • 1106 Second Street • Eureka, CA 95501 •
Ph. (707) 445-7493 Fax 445-7409

PROJECT:	HUMBOLDT COUNTY JUVENILE HALL REPLACEMENT FACILITY 2006 Harrison Ave., Eureka, CA 95501 Project No. 170212
From:	
SURETY: Construction Contract Takeover	WESTERN SURETY CO. C/O: Nancy Stangel 151 North Franklin St, 17 th Floor Chicago, IL 60606

COST PROPOSAL NO:	122.0
Date:	8/13/2020
RFCP No:	
RFI No.:	
LOI No.:	
Adjustment of Contract Sum:	\$551.44
Adjustment of Contract Time (Calendar Days):	0

SUBJECT: Switch out data faceplates to Stainless Steel Finish**INSTRUCTIONS:**

- 1) Complete this form by providing (a) all information required above, (b) the amount and justification base on the Contract Schedule for an adjustment of Contract Time, (c) the proposed adjustment of Contract Sum.
- 2) Attach detailed cost breakdowns for all materials, wages and salaries, and fringe benefits and payroll taxes.
- 3) The Fee shall be computed on the cost of Extra Work only; and shall constitute full compensation for all costs and expenses directly and indirectly related to the subject change.

DESCRIPTION OF CHANGE: (Include justification of adjustment in Contract Time based upon the Contract Schedule)

Cost Proposal for the changed scope of work is per the County Architect's request. Per Specification Section 27 30 00 para 2.7B (attached) and approved submittal 69.0 (attached), the data faceplates are called out to be a White finish. CP 122.0 is for the additional cost in material to furnish stainless steel faceplates for the new Juvenile Hall building.

Surety is forwarding this proposal in its capacity as Surety and it is not assuming any obligations or liabilities beyond those set forth in the Bonds. Surety has not verified or certified any of the information contained herein

Submitted By:	Patrick Weller	<small>Digitally signed by Patrick Weller DN: C=US, E=pweller@jsheld.com, O=JS Held, OU=Surety, CN=Patrick Weller Reason: Authorized Representative Date: 2020.08.14 11:14:19-07'00'</small>
Western Surety Co.	Name	Date
Reviewed By:	Deven Carter	<small>Digitally signed by Deven Carter DN: C=US, E=carter@nmrdesign.com, O=NMR Architects, CN=Deven Carter Date: 2020.08.14 14:36:27-07'00'</small>
Architect	Name	Date
Reviewed By:		08/25/2020
Public Works	Name	Date



13 August 2020

Mr. Jeff Smith
Humboldt County Department of Public Works
1106 Second Street
Eureka, CA 95501

HHCI Letter No.: 16135-CP#122.0

Sent via Email:
jeff@lendersconstructionservices.com

Project: HHCI Job #16135 - Humboldt County Juvenile Hall Replacement Facility, Project #170212

Subject: Data Faceplates

Dear Mr. Smith,

Please see attached CP 122.0 to switch the data faceplates per the County Architect's request to a stainless steel finish. Per Specification Section 27 30 00 para 2.7B (attached) and approved submittal 69.0 (attached), the data faceplates are called out to be a White finish. Pursuant to Specification Section 01-35-00, Modification Procedures, of our contract, this letter shall serve as our written request that a Change Order be issued for this extra work.

This change to our contract is an increase of \$551.44. This proposal is for acceptance within seven days and is subject to change and/or escalation thereafter.

Please reference HHCI CP#122.0 in all future correspondence regarding this matter. Please advise as soon as possible how we are to proceed. If there are any questions, please let me know.

Sincerely,

Karun Mani
Digitally signed by Karun Mani
DN: C=US,
E=kmani@halhays.com, O="Hal
Hays Construction, Inc.",
OU=Operations, CN=Karun Mani
Date: 2020.08.14 08:04:39-07'00'

HAL HAYS CONSTRUCTION, INC.
Karun Mani – Major Programs Manager

Encl: Cost Proposal CP 122.0 Cover Sheet
HHCI Backup Documents

PM Karun Mani
 Phone 951-205-3343
 Email kmani@halhays.com



Hal Hays Construction Inc.
 4181 Latham Street
 Riverside, CA 92501
 (951) 788-0703 Phone
 (951) 788-1517 Fax

HHCI Project No:	16135
Cost Proposal:	122
HHCI Proposal:	
LOI Number:	
Date:	13-Aug-2020

Project:	Humboldt County Juvenile Hall Replacement Facility		
Contract #:	170212		
Subject:	Data Faceplates		
Agency:	Humboldt County	CM:	Jeff Smith
		Phone:	(707) 496-9998
		Email:	jeff@lendersconstructionservices.com

Item No.	Description	UNIT	UOM	Labor		Material		Equipment		Subcontractor		Totals
				Cost	Total	Cost	Total	Cost	Total	Cost	Total	
Data Faceplates												
1	World Telecom											
Add	Switch data face plate to stainless steel in lieu of white per submittal 09	1	LS							\$	\$27.46	\$ 527.46
Deduct	10% Subcontractor OH&P	1	LS							\$	(47.95)	\$ (47.95)
										\$	-	\$ -
										\$	-	\$ -
										\$	-	\$ -
SUBTOTALS:										\$	-	\$ 479.51

Mark-Up on Labor	15.0%	\$0.00
Mark-Up on Materials & Equipment	15.0%	\$0.00
Mark-Up on Subcontractors (Incl. Sub mark-up)	15.0%	\$71.93
Grand Total of Change Order Request		\$551.44

--

 1819 Keystone Court Redding, CA 96003 P. 530-223-9753 F. 530-223-9186	Date:	8/12/2020
	Change Order #:	Humboldt County Juvenile WTS CO-004 (Stainless Steel Faceplates)
	Project Name:	Humboldt County Juvenile Hall Replacement Facility
	Attention:	Hal Hays Construction Inc.
	Reference:	Request has been made to switch out current approved white faceplates with Stainless Steel Faceplates

DISCRIPTION OF MATERIAL	QTY.	UNIT COST	EXT. COST	LABOR UNIT	LABOR EXT.	NOTES
			\$ -	0	0	
			\$ -		0.00	
Credit			\$ -		0.00	
Panduit - Mini-Com Executive Series 4-Port Faceplate (CFPE4WHY)	-59	\$ 1.85	\$ (109.15)	0.00	0.00	
Add			\$ -		0.00	
Panduit - Mini-Com Stainless Steel 4-Port Faceplate (CFPL4SY)	59	\$ 8.95	\$ 528.05	0.00	0.00	
			\$ -		0.00	
SUBTOTAL			\$ 418.90		0.00	

MATERIAL COST	\$ 418.90				
CONSUMABLES	\$ -	0.00% of labor			% of Labor
TOTAL MATERIAL	\$ 418.90				100%
MATERIAL TAX	\$ 35.61	8.50%			0%
SHIPPING	\$ -				0%
	\$ -				100%
TOTAL MATERIAL COST:	\$ 454.51		Cost		
TECHNICIAN	\$ -		RATE: \$ -		
INSTALLER	\$ -		RATE: \$ -		
	\$ -		RATE: \$ -		
OVERTIME BURDEN	\$ -		OT %: 0.00%		
PER DIEM	\$ -		PER DAY: \$ -		
HOTEL	\$ -		PER DAY: \$ -		
TRAVEL TIME	\$ -		HRS: 0		
SUBTOTAL	\$ -				DURATION BY TECHS: 2
DOCUMENTATION/As-Builts	\$ 25.00				0 HOURS
ADMINISTRATIVE COSTS	\$ -				0.00 DAYS
	\$ -				0.00 WEEKS
TOTAL LABOR COST:	\$ 25.00				
CLEAN-UP	\$ -	0.00% of labor			
SAFETY MEETINGS	\$ -	0.00% of labor			
Other	\$ -				
TOTAL DIRECT COST:	\$ -				
SUBCONTRACTOR -					
SUBCONTRACTOR -					
TOTAL SUBCONTRACTOR:					
TOTAL COST:	\$ 479.51				

COST ANALYSIS:		
0.00%	DIRECT COST MARKUP	\$0.00
10.00%	LABOR MARK UP	\$2.50
10.00%	MATERIAL MARK UP	\$45.45
10.00%	TOTAL MARK UP:	\$47.95
	TOTAL COST:	\$479.51

TOTAL CHANGE ORDER VALUE:	\$527.46
----------------------------------	-----------------

WT&S Contact:
 Todd Westlund
 Office: 530-223-9753
 FAX: 530-223-9186
 Email: todd@wtands.com

TERMS

The impact of this change includes only those items which can be identified at this time. However, should it be determined at a later date that we are experiencing identifiable cost impacts or time delays beyond our control due to this scope change or because of multiple scope changes, delays, or other causes, World Telecom & Surveillance, Inc. reserves the right to submit those costs and time extensions at that time. This proposal is based upon current material pricing and we reserve the right to adjust the proposed amount at the award of contract due to unforeseen circumstances in valuations of said materials. We reserve the right to correct this quote for errors and omissions. This quote covers direct costs only and we reserve the right to claim for impact and consequential costs.

This price is good for acceptance within 30 days from the date of receipt. We will supply and install all materials, labor and equipment as per your instructions.

ACCEPTANCE OF PROPOSAL TERMS

The above prices, specifications and conditions are satisfactory and are hereby accepted. You are authorized to do the work as specified.

This quote is only valid for 60 days from the date of proposal.

Date of acceptance: _____ Signature _____

A. Each Voice, Data & Voice/Data shall be provided with the components as described in coordination with electrical drawings.

B. Faceplate Outlets

1. 4-Port, white, Panduit #CFPE4WHY (Executive Series)
2. 6-Port, white, Panduit #CFPE6WHY (Executive Series)
3. Blank Snapin, Panduit #CMBWHY

C. Data Port

1. Category 6, RJ-45, Yellow.
2. Panduit #CJ688TPYL-Yellow

D. Voice Port

1. Category 3, RJ-11, Ivory.
2. Panduit #CJ66UEIY.

E. Wall Phone Outlet

1. Allen TEL #AT219-4-15.

2.8 OPEN WALL MOUNT RACK

- A. CPI Rack 19" wall mount 4' x 18" deep, Chatsworth #11807718-Black
- B. Vertical wire managers for wall mount rack, Ortonics Inc. #OR-VO-84-T3FTE-Black.

2.9 STANDING RELAY RACK

- A. 19 inch rack, Chatsworth #55053-703, Black

2.10 VERTICAL WIRE MANAGERS

- A. Panduit #PRV8-manager
- B. Panduit #PRD8-Door

2.11 HORIZONTAL WIRE MANAGERS

- A. B-Line (2RU) #SB7171933CFB, Black
- B. B-Line (4RU) #SB7171946CFB, Black

2.12 BLANK SPACER PANELS

- A. Panduit #CPAF1BLY, Black

2.13 PATCH PANELS

- A. 72 Port Angled Panels, Jack, Snapin, Panduit #CPPA72FMWBLY-Black
- B. 48 Port Angled Panels, Jack Snapin, Panduit #CPPA48FMWBLY-Black
- C. 24 Port Angled Panels, Jack, Snapin, Panduit #CPPA24FMWBLY-Black

2.14 CAT 6 JACKS

SUBMITTAL TRANSMITTAL

OWNER'S REPRESENTATIVE - Humboldt County Public Works, 1106 Second Street • Eureka, California 95501
Phone (707) 445-7493 Fax (707) 445-7409

PROJECT:	HUMBOLDT COUNTY JUVENILE HALL REPLACEMENT FACILITY	SUBMITTAL NO:	69.0
	2006 Harrison Ave., Eureka, CA 95501	Specification Section:	27-30-00
	Project No. 170212	Date:	06/19/17
FROM:		Drawing Ref. No.:	
CONTRACTOR:	Hal Hays Construction, Inc.	Subcontractor/Supplier:	Stephens Electric
	8850 Old Oregon Trail, Redding, CA 96002	Page No.:	
	Ph. 951-788-0703 x160	Cc:	
	Fx. 951-289-7112		

TRANSMITTAL RECORD	Date Sent	Date Rec'd	Quantity				Review Code
			Product Data	Shop Drawing	Sample	Other	
Contractor to Project Administrator	06/19/17	06/19/17	X				1. No Exceptions Taken 2. Implement Exceptions Noted 3. Revise And Resubmit 4. Rejected 5. Cancelled
Proj. Admin to Architect/Engineer	06/20/17		X				
Architect/Engineer to Administrator	06/23/17		x				
Architect to Engineer	06/20/17	06/20/17	X				
Engineer to Architect	06/21/17		X				
Project Administrator to Contractor	06/26/17		X				

REVIEW ACTION:

1	2	3	4	5	Drawing/Item	Dated	Description
✓					1	06/19/17	Telecom Copper Distribution

Owner/ Inspector Remarks:

Engineer/Consultant:

NOTE: Notations do not authorize changes to the contract amount or completion date. If you are authorized to proceed with the work identified in this submittal, it is assumed that no change in Contract amount or completion date is required. If the submittal involves a change in the work affecting your contract amount or completion date, notify the Architect and Owner representative immediately.



**COUNTY OF HUMBOLDT
 JUVENILE HALL REPLACEMENT FACILITY
 EUREKA, CA
 CONTRACT No. 170212
 HAL HAYS JOB No. 16135**

**Submittal Number: 69.0
 Specification Section: 27-30-00
 Telecom Cooper Distribution**

I certify that all materials, products, field dimensions, adjacent construction Work and coordination of information that are to be incorporated into the work have been reviewed in detail and are approved to be in conformance with the contract requirements, except as otherwise stated below.

Signature: Jay Mulligan
 Print Name: Jay Mulligan

Date: 06/19/2017
 Title: Project Manager

LP Consulting Engineers, Inc.		
<input checked="" type="checkbox"/> NO EXCEPTIONS TAKEN	<input type="checkbox"/> MAKE CORRECTIONS NOTED	<input type="checkbox"/> SUBMIT SPECIFIED ITEMS
<input type="checkbox"/> REJECTED	<input type="checkbox"/> REVISE & RESUBMIT	<input type="checkbox"/> SEE ATTACHED LETTER
DATE: 6/21/2017	BY: Ken Rubitsky	
<small>CORRECTIONS OR COMMENTS MADE ON THE SHOP DRAWINGS DURING THIS REVIEW DO NOT RELIEVE CONTRACTOR FROM COMPLIANCE WITH REQUIREMENTS OF THE DRAWINGS AND SPECIFICATIONS. THIS CHECK IS ONLY FOR REVIEW OF GENERAL CONFORMANCE WITH THE DESIGN CONCEPT OF THE PROJECT AND GENERAL COMPLIANCE WITH THE INFORMATION GIVEN IN THE CONTRACT DOCUMENTS. THE CONTRACTOR IS RESPONSIBLE FOR CONFIRMING AND CORRELATING ALL QUANTITIES AND DIMENSIONS, SELECTING FABRICATION PROCESSES AND TECHNIQUES OF OTHER SATISFACTORY CONSTRUCTION, COORDINATING HIS WORK WITH THAT OF ALL OTHER TRADES AND PERFORMING HIS WORK IN A SAFE AND SATISFACTORY MANNER.</small>		



World Telecom & Surveillance, Inc.

"Where Integrity and Affordability Come First"

Humboldt County Juvenile Hall Replacement Facility

Product Submittal for:

27 30 00 Telecommunication Copper Distribution

PROJECT NAME AND ADDRESS

Humboldt Juvenile Hall
Humboldt County Juvenile Hall
Eureka, CA

OWNER

County of Humboldt
1106 Second St.
Eureka, CA 95501

GENERAL CONTRACTOR

Hal Hays Construction, Inc.
4181 Latham Street
Riverside, CA 92501

COMMUNICATIONS CONTRACTOR

World Telecom & Surveillance, Inc.
1819 Keystone Court
Redding, California 96003

May 17, 2017

Submittal Prepared By: Stephanie Shafer
World Telecom & Surveillance, Inc ▪ 1819 Keystone Court ▪ Redding, CA 96003
Contact: Stephanie Shafer ▪ Phone: (530) 223-9753 ▪ Fax: (530) 223-9186

HUMBOLDT COUNTY JUVENILE HALL REPLACEMENT FACILITY INDEX SHEET



**WORLD
TELECOM &
SURVEILLANCE INC.**

273000 - TELECOMMUNICATION COPPER DISTRIBUTION

MANUFACTURER - DESCRIPTION	PART NUMBER	NOTE
Comtran Cable - OSP 24 AWG 50-Pair Riser Cat 3 Communication Cable	DS33572	
General Cable - Category 6, 4-pair, Yellow	7133802	6NP4P24-YL-S-GCC-PV
General Cable - Category 3, 4-pair, Gray	2133017	3NP4P24-GY-P-GCC-PV
Panduit - Cat 6 Jacks, Black	CJ688TPBL	
Panduit - Cat 6 Jacks, Yellow	CJ688TPYL	
Panduit - Cat 3 Jacks	CJ66UEIY	
Allen Tel - Wall Phone Jack	AT219-4-15	
Panduit - Mini-Com Executive Series 4-port Faceplate	CFPE4WHY	
Panduit - Mini-Com High Density Modular Patch Panel	CPPA72FMWBLY	
Panduit - Rack Blank Filler Panel	CPAF1BLY	
Panduit - Vertical Cable Manager	PRV8	
Panduit - Vertical Cable Manager Dual Hinged Doors	PRD8	
CPI - Standard Floor Rack	55053-703	
CPI - Universal Cable Runway	10250-712	
CPI - Channel Rack-to-Runway Mounting Plate	10595-712	
CPI - Wall Angle Support Kit	11421-712	
B-line - Horizontal Wire Manager	SB7171933CFB	
B-line - Horizontal Wire Manager	SB7171946CFB	
Belden - 250 Pair Bix Block	A0270164	
Belden - 300 Pair Bix Block	A0340836	
Belden - 25-Pair Bix Connector, 5-Pair Markings	A0266828	
Belden - 25-Pair Bix Connector, 4-Pair Markings	A0393146	
Belden - Distribution Ring	A0270168	
Wiremond Legrand - Rack Mount Surge Protector	R5BZ-15	
Cablofil - Cable Tray, 4x12x120L, Black	CF105/300BL	
Arlington - Loops	TL25	
Arlington - Loops	TL50	
Shaxon Industries - 5' Cat6 Patch Cord with Boots, Yellow	UL624M805YL-7F	
Shaxon Industries - 7' Cat6 Patch Cord with Boots, Yellow	UL724M807YL-7F	

Mini-Com® Executive Series Faceplates

PANDUIT
SPECIFICATION SHEET

specifications

Faceplates shall be available in 1, 2, 4, and 6-port single gang and 10-port double gang with label and label cover for easy identification. Each faceplate shall accept Mini-Com® Modules for UTP, STP, fiber optic, and audio/video that snap in and out. Executive Series faceplates shall have a raised profile for an aesthetic appearance.



technical information

Mounting options:	Screw holes with retention tabs, spaced for single and double gang openings; compatible with Panduit wall board adapters
Packaging:	Supplied with two or four 1" long, #6 – 32 slotted head screws, labels and label covers; faceplates packaged one per bag, ten per box

key features and benefits

Modular	Accepts all Mini-Com® Modules which snap in and out for easy moves, adds, and changes
Identification	Includes built-in label pocket for easy identification
Various port densities	Provides design flexibility
Slotted screw holes	Allows faceplate to be adjusted to ensure proper alignment

applications

Mini-Com® Executive Series Faceplates are compatible with standard size single gang and double gang junction boxes. Faceplates can also be mounted to wallboard adapters and raceway mounting brackets. When using executive series faceplates with Panduit surface raceway, color matching is guaranteed. Labeling of executive series

faceplates is easy with enclosed write-on labels, or with Panduit computer printable labels. If labels are not needed, matching screw covers can be used to conceal the screws and will mount flush with the faceplate for a clean look.

Single Gang Faceplates

1-port:	CFPE1IWY*
2-port:	CFPE2IWY*
4-port:	CFPE4IWY*
6-port[^]:	CFPE6IWY*

Label Options for Single Gang Faceplates

Laser/ink jet:	C195X040Y1J
Panther™ LS8E:	C195X040Y1C

Double Gang Faceplates

10-port:	CFPE10IW-2GY*
-----------------	---------------

Label Options for Double Gang Faceplates

Laser/ink jet:	C288X040Y1J
Panther™ LS8E:	C288X040Y1C

Wall Board Adapters

Single gang:	MWBA1
Double gang:	MWBA-2G

Accessories

Replacement label and screw cover (single gang): EFPK-XY

Replacement label and screw cover (double gang): EFPK102G-XY

Screw cover: CSCIW-X*

*For other colors, replace suffix IW (Off White) with EI (Electric Ivory), WH (White), or IG (International Gray).

[^]6-port, single gang faceplates must be installed on a 1.9" wide (or wider) electrical back box.

Mini-Com® Executive Series Faceplates

single gang faceplates

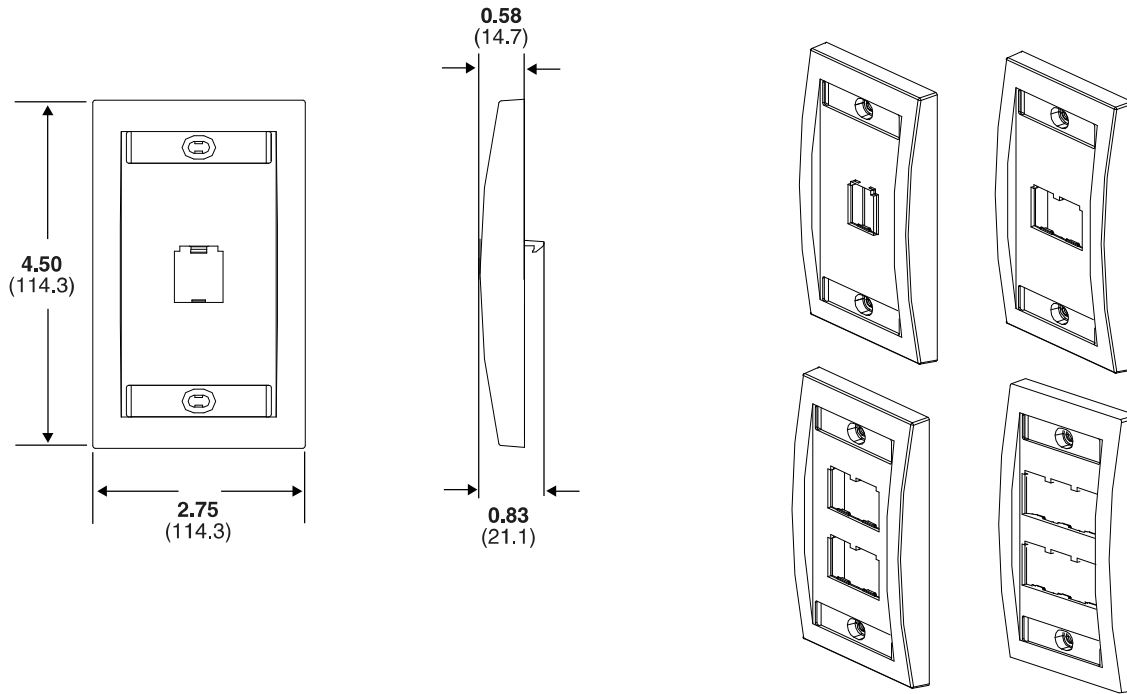

double gang faceplates

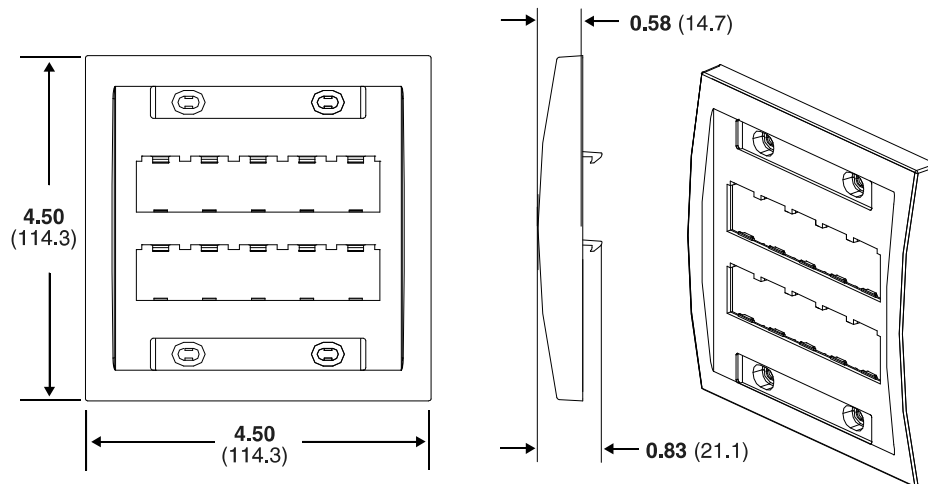

Dimensions are in inches (Dimensions in parentheses are metric)

WORLDWIDE SUBSIDIARIES AND SALES OFFICES

PANDUIT CANADA
Markham, Ontario
cs-cdn@panduit.com
Phone: 800.777.3300

PANDUIT EUROPE LTD.
London, UK
cs-emea@panduit.com
Phone: 44.20.8601.7200

PANDUIT SINGAPORE PTE. LTD.
Republic of Singapore
cs-ap@panduit.com
Phone: 65.6305.7575

PANDUIT JAPAN
Tokyo, Japan
cs-japan@panduit.com
Phone: 81.3.6863.6000

PANDUIT LATIN AMERICA
Guadalajara, Mexico
cs-la@panduit.com
Phone: 52.33.3777.6000

PANDUIT AUSTRALIA PTY. LTD.
Victoria, Australia
cs-aus@panduit.com
Phone: 61.3.9794.9020

For a copy of Panduit product warranties, log on to www.panduit.com/warranty

For more information

Visit us at www.panduit.com

Contact Customer Service by email: cs@panduit.com
or by phone: 800.777.3300 and reference OTSP21

PANDUIT®

©2015 Panduit Corp.
ALL RIGHTS RESERVED.

WW-OTSP21
5/2015