

Site Management Plan

Green With Envy

000 Burr Valley Road Dinsmore, CA 95526

APNs: 210-131-015, 210-131-017, 210-131-018

1_12CC429133

By: ETA Humboldt

Prepared by Vanessa Valare

09/02/2021

Purpose

This Site Management Plan (SMP) has been prepared on behalf of the cannabis cultivator for the Humboldt County property identified as assessor parcel numbers 210-131-015, 210-131-017, and 210-131-018, by agreement and in response to the State Water Resources Control Board Cannabis Cultivation Policy (Cannabis Policy), in congruence with General Waste Discharge Requirements for Discharges of Waste Associated with Cannabis Cultivation Activities (General Order). The General Order implements the Cannabis Policy requirements, specifically those requirements that address waste discharges associated with cannabis cultivation activities. Dischargers covered under the General Order are subject to the requirements of the Cannabis Policy in its entirety. The Cannabis Policy provides a statewide tiered approach for permitting discharges and threatened discharges of waste from cannabis cultivation and associated activities, establishes a personal use exemption standard, and provides conditional exemption criteria for activities with a low threat to water quality.

Tier Designation

Tiers are defined by the amount of disturbed area. Tier 1 outdoor commercial cultivation activities disturb an area equal to or greater than 2,000 square feet and less than 1 acre (43,560 square feet). Tier 2 outdoor commercial cultivation activities disturb an area equal to or greater than 1 acre. Risk designation for Tier 1 and Tier 2 enrollees under the Cannabis Policy is based on the slope of disturbed areas and the proximity to a surface water body. Characterization is based on the risk designation summarized in Table 1 below.

Thorough assessment of the project area including roads, disturbed areas, legacy features, and cultivation areas put this enrollment into the classification of **Tier 1, Low Risk**.

Scope of Report

Tier 1 and Tier 2 cannabis cultivators are required to submit and implement a Site Management Plan that describes how they are complying with the Requirements listed in Attachment A. Cannabis cultivators within the North Coast Regional Water Quality Control Board jurisdiction are required to submit and implement Site Management Plans that describe how the Requirements are implemented property-wide, to include legacy activities. The Discharger shall ensure that all site operating personnel are familiar with the contents of the General Order and all technical reports prepared for the property. A copy of the General Order, and technical reports required by the General Order, shall be kept at the cultivation site.

Methods

The methods used to develop this SMP include both field and office components. The office component consisted of aerial photography review and interpretation, existing USGS quad map review, GIS mapping of field data, review of on-site photography points, streamflow calculations, general planning, and information gathered from the cannabis cultivator and/or landowner. The field component included mapping of all access roads, vehicle parking areas, Waters of the State, stream crossings, drainage features, cultivation sites, buildings, disturbed areas, and all other relevant site features within the project area and surrounding areas (as feasible). Cultivation areas, associated facilities, roads, and other developed and/or disturbed areas were assessed for discharges and related controllable water quality factors from the activities listed in the General Order.

General Site Information

Discharger: Green With Envy, LLC

Landowner: PCH Management Group

GPS: 210-131-015 40.4159, -123.5988 210-131-017 40.4160, -123.6035 210-131-018-40.4153, -123.6011

Location: 5188 Burr Valley Rd. Dinsmore, CA 95526

Parcel Numbers: 210-131-015, 210-131-017, 210-131-018

Parcel Size: 80 acres combined (parcel -015= 40-acres, parcel 017= 20-acres parcel -018= 20-acres)

Cumulative Disturbed Area: approx. 41,000ft²

Cultivation Area and Type: 36,150ft² Outdoor Light Deprivation

Tier Level: 1

Risk Level: Low

1. Site Characteristics

1.1 General

These three parcels combined equal to 80 acres of evergreen forest, mixed forest and grassland. Total disturbed area is approx. 41,000 square feet. Total current cultivation area is 36,150ft²

The applicant is dedicated to minimizing any negative impact to the rural community and natural environment surrounding this parcel. The applicant has owned and maintained the land for over 30 years and is committed to operating his business in an environmentally responsible manner. This would include eliminating light pollution, noise pollution, or any other adverse effect to neighbors. The applicant adheres to BMP in protecting the environment and works closely with county and state agencies to keep in compliance and run a safe clean farm. The applicant's business functions with great regard for the ecosystem in which it operates.

- A. The applicant's plans are to use the natural prime ag soils and only organic amendments to fortify the soil as needed.
- B. Soil samples will be taken and analyzed to ensure proper balance of nutrients are being used.
- C. Branches harvested during fuel reduction are composted and eventually used in swales, pathways, and remediation buffers to prevent nutrient runoff, reduce soil temperature, store carbon, and promote a healthy soil microbial community.
- D. Soil fertility is closely monitored to prevent excess use of fertilizers.
- E. Only organic products are used in the cultivation of cannabis.
- F. Cultivated soils are cover cropped and mulched in the off season to enhance soil fertility

and eliminate runoff; and

- G. The entire site is monitored to identify and correct any potential sources of environmental degradation and maintain a protective riparian buffer

1.2 APN: 210-131-015 Structures currently on Site

Structures on the property relevant to the cultivation process on this parcel include:

Greenhouse A- 2,360 ft² of light deprivation cultivation

Greenhouse B- 2,096 ft² of light deprivation cultivation

Greenhouse C- 960 ft² of light deprivation cultivation

Greenhouse D- 1,296 ft² of light deprivation cultivation

Greenhouse E- 1,728 ft² of light deprivation cultivation

Greenhouse F- 1,200 ft² of light deprivation cultivation

Greenhouse G- 803 ft² of light deprivation cultivation

Greenhouse H- 803 ft² of light deprivation cultivation

Greenhouse I- 803 ft² of light deprivation cultivation

Greenhouse J- 950 ft² of light deprivation cultivation

Greenhouse K- 1,012 ft² of light deprivation cultivation

Greenhouse L- 1,012 ft² of light deprivation cultivation

Greenhouse M- 1,012 ft² of light deprivation cultivation

Greenhouse N- 720 ft² of light deprivation cultivation

Greenhouse O- 545 ft² of light deprivation cultivation

Greenhouse P- 480 ft² of light deprivation cultivation

1.2 APN: 210-131-017 Structures currently on Site

Existing Structures on the property relevant to the cultivation process on this parcel include:

Greenhouse 1- 3,840ft² of light deprivation cultivation

Greenhouse 2- 3,840ft² of light deprivation cultivation

Greenhouse 3- 2,320ft² of light deprivation cultivation

Connex Container- 8' X 20' AG storage

Connex Container- 8' X 20' AG storage

Connex Container- 8' X 20' Fertilizer/Pesticide Storage

Processing Building- 1,400ft² drying/processing/Nursery

1.2 APN: 210-131-018 Structures currently on Site

Existing Structures on the property relevant to the cultivation process on this parcel include:

Greenhouse 1- 1,674 ft² of Light Deprivation Cultivation.

Greenhouse 2- 1,674 ft² of light deprivation cultivation.

Greenhouse 3- 1,674 ft² of light deprivation cultivation.

Greenhouse 4- 1,674 ft² of light deprivation cultivation.

Greenhouse 5- 1,674 ft² of light deprivation cultivation.

Residence- 2,000ft² place of residence

Drying/Processing Building- 2,000ft² space for drying and processing of harvested cannabis

Storage Containers- 2 qty. 160ft storage containers for misc. storage

Propagation Area 1- 560ft² of propagation space for Vegetative Plants

Propagation Area 2- 480ft² of propagation space for Vegetative Plants

Pesticide and Nutrient Storage- 160ft² storage area

1.3 Access Roads

The site is located on Burr Valley Rd. in the Bridgeville Area. Personal driveway is shared with no additional neighbors. To access property from Eureka CA, via Highway 101:

Take Highway 101 south for 19.9 miles to the State Highway 36 exit. (exit 685 E). Turn left onto State highway 36. Follow State highway 36 .35.3 miles to Burr Valley Rd. Turn right onto Burr Valley Rd. Follow Burr Valley Road for 2.4 mi. Destination will be on the left.

1.4 Stream Crossings

There is one (1) Class II watercourse, Dairy Creek, which is Tributary to the Little Van Duzen River on parcel 210-131-015. There are three (3) unnamed Class III watercourses that flow into Dairy Creek on the parcel. There are two (2) watercourse crossings on parcel 210-131-015. There is one (1) unnamed watercourse which flows into Dairy Creek on parcel 210-131-017. There are no watercourse crossings on this parcel. There are three (3) unnamed Class III watercourses that flow into Dairy Creek on parcel 210-131-018. There are two (2) watercourse crossings on this parcel.

1.5 Electricity

Power for these parcels is currently provided by a 25KW Generator. There is another 25kw generator on site for back-up, and several small Honda generators that are used for smaller purposes such as greenhouse fans when large generator isn't needed. Applicant plans to add a solar system to shift this project's energy use to a more environmentally friendly power system as soon as their budget allows. Applicant estimates that they will be able to switch to solar power by 2026.

1.5.1 Artificial Lighting

Propagation greenhouses use a small amount of supplemental lighting. Two sets of String lights with 10-23w bulbs each for a total of 460w for each greenhouse.

1.6 Species of Concern

The following species that have been recorded within the quadrat (Dinsmore)

Foothill Yellow-Legged Frog

Northern Goshawk

Flammulated Owl

Northern Spotted Owl

Willow Flycatcher

Steelhead- Northern California DPS

Summer Run Steelhead Trout

Wawond Riffle Beetle

Sonoma Tree Vole

North American Porcupine

Western Pond Turtle

2. Cultivation Plan

2.1 Cultivation Areas on 210-131-015

The following areas are designated for cultivation activities:

- Sixteen (16) existing flowering greenhouses totaling 17,780ft².
- Total current cultivation area is 17,780 square feet.

2.1a Cultivation Areas on 210-131-017

The following areas are designated for cultivation activities:

- Three (3) existing flowering greenhouses totaling 10,000ft².

- Three (3) Connex Containers (8' x 20') used to store pesticides/nutrients, refuse and recycling.
- One (1) drying/processing building (20' X 70')

2.1b Cultivation Areas on 210-131-018

The following areas are designated for cultivation activities:

- Five (5) existing flowering greenhouses for a total of 8,370ft²
- Three (3) Connex Containers (8' X 20' used to Store pesticides/Nutrients and Secured Harvest area for harvested Cannabis
- Processing Building- 2,000ft² drying/processing building (40' X 50')

2.2 Harvesting

Cannabis will be harvested using gloves and clean tools. All cannabis will be hung to dry on-site in the drying rooms on parcels 210-131-017, and 210-131-018. A dehumidifier and fans as well as will be added to the drying areas. Cannabis will be dried for 10-21 days on lines in this area depending on weather. The rooms will have proper ventilation, fans, and dehumidifiers to maintain proper environment. Moldy cannabis will be removed and destroyed using county and state approved procedures for holding and destroying unwanted product.

Cannabis trimming will occur as cannabis becomes ready from curing process. Using a processing center for trimming would be the ideal scenario in the future. Until then, trimming will physically take place in the drying areas with plenty of ventilation and fresh air or outside when weather permits. The applicant plans to trim the cannabis them self by hand with the aid of a trim machine. If needed they will hire independent contractors with processor's licenses to help. Processed cannabis will be bagged into turkey bags or sealed bags to be held until a distributor is ready. The trim or remaining leaves from processed cannabis, will be bagged into brown lawn bags and into contractor bags to be stored until needed, sold, or destroyed in the legal manner.

2.2.1 Employees/Contract Workers

The applicant intends to do all the work themselves, however if the need arises for help independent contractors will be hired to help in their respective fields. Employees/contractors will have access to parking, spacious work zone, clean supplies for task, hand washing areas with soap, and a portable toilet. All areas will be kept clean and in good condition. All employees/contractors will have access to personal safety equipment to meet the needs of the job for example, face mask, gloves, Tyvek suits, safety glasses, rubber boot covers etc. For the purposes of this document the term "employee" will refer to all people working on site. Additionally, the following practices will be implemented and only employ persons for hire as allowable by law. At all times workers shall have access to safe drinking water, toilets, and washing facilities. Applicant has created a Worker Safety Practices outline as follows:

Safety protocols will be implemented to protect the health and safety of employees. All employees shall be provided with adequate safety training relevant to their specific job functions, which may include:

- 1) Employee accident reporting
- 2) Security breach
- 3) Fire prevention
- 4) Materials handling policies
- 5) Use of protective clothing such as long sleeve shirts, brimmed hats, and sunglasses.

Each garden site and or processing area have the following emergency equipment:

- 1) Personal protective equipment including gloves and respiratory protection are provided where necessary
- 2) Fire extinguisher
- 3) First Aid Kit
- 4) Snake Bite/Bee Sting Kit
- 5) Eye Washing Kit

Comply with all applicable federal, state, and local laws and regulations governing California Agricultural Employers, which may include federal and state wage and hour laws, CAL/OSHA, OSHA, California Agricultural Labor Relations Act, and the Humboldt County Code (including the Building Code).

2.3 Monthly Cultivation Site Activities

Table 1: Monthly Cultivation Site Activities

Month	Activities
January	Finish processing of fall harvest, trimming and storage. Plan new year. Mow cover crop. Check greenhouses for issues/fix. Check water lines, tanks and all equipment for repairs or damages. Make plan for repairs.
February	Work on trenches/and holes for plants and layer more compost in beds. Treat compost if necessary. Finishing processing last year's crop if necessary.
March	Get clones from other permitted grow operation. Transplant and move into garage with seedlings. Amend beds, fix fences, service equipment, make plan for independent contractors such as painting, fence building, greenhouse fixing, etc.
April	Amend and start turning beds, prepare soil and supplies for greenhouse plants. Add nematodes compost for pest prevention. Mid- April move first round of plants to greenhouses. Weed whacking, mowing, and brush cleanup.

May	Spray with preventive sulfur. Treat with biodynamic preparations for pest control and mold control. Greenhouse plants switched into flower using a blackout cover mid-late May. Double check all water systems for leaks and clogs. Put out sound sensors for rodents.
June	Hay put over each trench for water retention and erosion prevention. Regular feeding schedule of compost teas adhered to. Pests are dealt with as they arise with oils, nematodes and predator mites from compost. Procure next round of plants from licensed nursery.
July	Harvest greenhouses, replant with new clones from a permitted nursery. Treat plants with preventive measures. Harvested flowers to hang in garage, then to be cured and hand trimmed per processing plan.
August	Finish processing July's harvest. Monitor water supply, check lines and all areas for insect/ animal disturbance.
September	Prepare for Harvest. Clean and prepare lines and drying spaces in drying areas. Clean all supplies and purchase new items needed. Harvest, cure and trim cannabis.
October	Harvest greenhouses and process as outlined above. Pull all root-balls, pack hay and cover crop seeds on beds. Pull drip system. Check all equipment and tools for leaks and damages before storing for winter. Store all supplies possible, cleanup site.
November	Winterize water system, greenhouses, and sheds. Clean up drying rooms remove all lines and debris. Put away all supplies i.e., fans, dehumidifiers. Continue processing cannabis as outlined above.
December	Start amendments for winter. Prep all water and water storage system for shut down. Clean all garden implements. Put all left over supplies away. Driveway fixing, other farm/garden maintenance.

3. Water

3.1 Source and System

The irrigation water source for this operation is rainwater catchment system consisting of three offstream rainwater catchment reservoirs. Two of the offstream reservoirs are located on 210-131-018, (179,532-gallon and 230,400-gallon) and one reservoir (250,000-gallon) is located on parcel 210-131-017. Total capacity of rainwater catchment reservoirs is 659,932-gallons. Cultivation Site on 210-131-015 will use approx. 163,538-gallons of water per year. Cultivation site on 210-131-017 will use approx. 93,802-gallons of water per year. Cultivation site on 210-131-018 will use approx. 76,900-gallons of water per year. Total irrigation water use for the combined projects is approximately 334,240-gallons per year. There is a spring labeled domestic use only spring on the map, used for domestic purposes only. Domestic water use is estimated to be approx. 74,500 gallons per year for entire property.

3.2 Storage

There are a total of eleven (11) HDPE water storage tanks (8 Irrigation tanks and 3 domestic use tanks) on this property. There are three (3) 3,000-gallon HDPE water storage tanks, three

(3) 2,500-gallon HDPE water storage tanks, one (1) 2,600-gallon HDPE water storage tank, and one (1) 1,200-GALLON HDPE water storage tank filled from the rainwater catchment reservoirs for irrigation use. There are three (3) 3,000-gallon HDPE tanks filled from the Domestic Spring for domestic water use. Domestic use tanks are filled by gravity from Domestic Spring. Irrigation Water storage tanks will be filled by pump from rainwater catchment reservoirs. There is also a 22,000-gallon Water Storage Bladder that is reserved for firefighting use. Applicant is proposing to add eight (8) 5,000-gallon, two (2) 1,500-gallon, and three (3) 1,200-gallon HDPE water storage tanks to increase water Storage.

3.3 Use

The water is used for onsite irrigation and foliar spraying. The irrigation systems employed include drip irrigation and hand watering. Domestic water is used for handwashing stations, drinking water, and for the residence.

3.4 Conservation Methods Employed

Water use is monitored. Rice hay is utilized on surface of garden beds to reduce evaporative water loss.

3.5 System Maintenance

Entire water system including manifolds and fittings are inspected weekly for leaks, and drip system is inspected daily for leaks and damage.

4. Erosion and Sedimentation

4.1 Points of Concern

There are two culverts and a rock for that need to be upgraded to appropriate sizing to handle 100-year storm flow concerns, and there is a spillway at one of the ponds that needs to be upgraded. All points of concern have been notified for on CDFW Lake and Streambed Alteration Agreement in progress.

4.2 Soil Management

The soil used onsite consists of a premixed soil blend in combination with coco coir. Soil deficiencies are determined by testing the soil, observation of the crop health and comparison of crop yields. Soils on site are reused and amended, rather than disposed of. This site has no problems with soil erosion.

4.3. Maintenance

Some of the soil conservation measures employed include the use of firebreaks, the encouragement of winter cover crops and general maintenance of the wildlife habitat.

5. Fertilizers, Herbicides and Pest Management

The applicant will follow best organic operation practices. Fertilizers, amendments, or other agro-chemicals will be stored in dedicated locations within the first-floor garage of the residence. All fertilizers or other regulated and non-regulated agro-chemicals shall be stored within covered areas with secondary containment. Fertilizers, potting soils, compost, and other soils and soil amendments are currently stored in structures on the property in a manner in which they will not

enter or be transported into surface waters and so that nutrients or other pollutants will not be leached into groundwater. Fertilizers and soil amendments are applied and used per the manufacturers guidelines. Cultivation areas are currently maintained so as to prevent nutrients from leaving the site during the growing season and post-harvest.

5.1 Herbicides/Weed Control

Biological, physical, and cultural methods of weed control are employed. Hand-pulling weeds and weed eating are the primary methods used onsite for weed reduction.

5.1.2 Storage

Herbicides and fertilizers present on site will be stored in a shed or container with a locked door

5.2 Pest Management

This Pest Management Plan was prepared to comply with California Department of Food and Agriculture requirements for CalCannabis cultivation licensing. This plan describes various pest management options that the applicant will employ depending on conditions and circumstances. All pesticides and practices used will comply with California Department of Pesticide Regulation and the Humboldt County Agricultural Commissioner's enforcement the use and sale of pesticides under Divisions 6 and 7 of the California Food and Agricultural Code, and Title 3 of the California Code of Regulations. The use of pesticide products is consistent with product labeling and all products on the property are to be currently stored in closed structures to ensure that they do not enter or are released into surface or ground waters.

The applicant will be utilizing proper crop spacing, using proper nutrient levels and pH balance to minimize the spread of insects. The applicant will choose plant strains with genetics that have resistance to pest. Timing crop planting will also be utilized.

If deemed beneficial, the applicant will utilize lady bugs to control mite infestations, or any other predator insect that is approved for use.

The applicant will be utilizing chemicals as a preventative. The chemicals will be applied as a foliar spray. All products are OMRI listed and are organic.

Product Name	Active Ingredients
Neem Oil	Azadirachtin
Micro-ionized Sulfur	Sulfur
Green Cleaner	Soybean Oil, Sodium Lauryl Sulfate, Citric Acid, Isopropanol Alcohol

5.2.2 Storage

All chemicals shall be stored and handled according to the manufacturers recommendation and as outlined by the CDFA or any other best practices as outlined by a cannabis licensing bureau.

Pesticides, fungicides, and other biocides on site will be stored in a container or shed with a locked door.

6. Petroleum, Gas and Oil

6.1 Use

Petrol products will be used in a generator on site for emergency back-up power artificial lighting, fans, dehumidifiers, and other electric devices associated with the cultivation process.

6.2 Storage

The petroleum products will be stored in approved containers in a covered shed with containment devices in place.

7. Waste

7.1.1 Cultivation Waste

CERCC (Clean Energy Resource Conservation Commission) requires that the project comply with the California Integrated Waste Management Act (CIWMA). In addition to cannabis waste, which is regulated by CERCC, the CIWMA requires that the project manage recycling of commercial solid waste and organic waste. The following project policies are regulated by local and state requirements:

A. All cannabis waste shall be stored in a secure waste receptacle, or secured area, and disposed of in accordance with local and state regulations. "Secure waste receptacle" or "secured area" means that physical access to the receptacle or area is restricted to the licensee and its employees, or the local agency, or waste hauler franchised or contracted by a local agency.

B. Public access to the designated cannabis waste receptacle or area shall be strictly prohibited.

C. All commercial solid waste shall be stored separately from cannabis waste in disposal bins secure from wildlife and watershed discharge, divided out from trash and recyclables, and disposed in accordance local and state regulations.

D. All hazardous waste regulated by the Integrated Pest Management Plan shall be dispose of properly utilizing protocols within that plan in compliance with all local and state regulations.

7.1.2 Tracking, Records, and Inspections

CERCC requires that the project comply with the Track-and-Trace System and local requirements. The following policies shall be implemented to ensure compliance with the local and state requirements:

7.1.2 Tracking, Records, and Inspections (Continued)

A. In addition to all other tracking requirements, disposal of cannabis waste shall use the Track-and-Trace System with documentation to ensure cannabis waste is identified, weighed, and tracked while on premises and when disposed.

B. All cannabis plant material identified as cannabis waste shall be reported in the Track-and-Trace System made within three (3) business days of the change in disposition from cannabis plant material into cannabis waste scheduled for destruction or disposal.

C. Review of on-site cannabis, Track-and-Trace System records, cannabis waste, commercial waste, and any other records shall be available for CDFA (California Dept of Food and Agriculture) inspection or their designated representative. Inspections shall occur at standard business hours from 8:00am to 5:00pm. Prior notice for inspections is not required by the inspecting agency.

D. No person shall interfere with, obstruct, or impede inspection, investigation or audit. This includes, but is not limited to, the following actions: Denying the department access to the licensed premises. Providing false or misleading statements. Providing false, falsified, fraudulent or misleading documents and records, and failing to provide records, reports, and other supporting documents.

E. Accurate and comprehensive records shall be maintained on-site for seven (7) years regarding cannabis waste which are subject to CDFA inspection that account for, reconcile, and evidence all activity related to the generation or disposition of cannabis waste.

7.1.3 Internal Waste Management Policies

The following waste management policies shall be implemented to ensure compliance with the local and state regulations, as well as CIWMA, CERCC and, CWMP (Cannabis Waste Management Plan):

A. The CWMP shall always be retained onsite. **B.** Each new laborer that comes onto the site shall be provided with a copy of the CWMP and it shall be their responsibility to read the CWMP.

C. The operator shall instruct all laborers as to the location and proper disposal of cannabis waste.

D. The operator shall monitor the process of waste management and reuse of cannabis waste to ensure compliance with the CWMP, local requirements, Integrated Waste Management Act, and CERCC.

E. The operator shall ensure that all supporting documentation which demonstrates compliance with the CWMP is provided to the local or state enforcement agency upon request or when required.

F. Waste reduction and recycling strategies shall be periodically reviewed.

G. Every effort shall be made to use to reduce the amount of cannabis waste sent to landfills by on-site composting and reuse.

H. Any person hauling away cannabis waste shall notify the operator of the materials, location of disposal, and provide written record.

I. The waste hauler shall track the total amount of cannabis waste leaving the project by weight or by volume and supply the operator with copies of tickets or detailed receipts from all loads of cannabis waste removed from the site

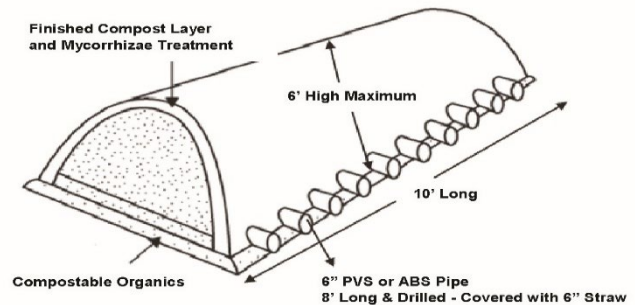
7.1.4 On Site Cultivation Waste Disposal

The CWMP identifies one or more of the following approved methods for cannabis waste and organic waste according to the CIWMA, CERCC and, CWMP:

On-premises disposal of cannabis and organic waste: Composting cannabis waste shall comply with title 14 of the California Code of Regulations Division 7 Chapter 3.1 (commencing with Section 17850) by one or more of the following methods:

Passive Aerated Static Pile: a composting process that is similar to the aerated static pile except that the air source may or may not be controlled.

Land Application: final deposition of compostable material shall be spread on-site land (i.e., compost used within gardens).



7.2 Trash

Rubbish is stored in a secure area in the garage and is removed monthly. Solid waste is hauled to an approved county location.

The CWMP identifies one or more of the following methods for managing solid waste and recyclables according to the CIWMA, CERCC and, CWMP: self-haul refuse and recycling to approved county location.

Recology Eel River
965 Riverwalk Drive
Fortuna, CA 95540

7.3 Domestic Wastewater

Portable toilets are utilized for handling domestic wastewater. Portable toilets are cleaned regularly by septic disposal company.

7.4 Hazardous Waste

Gasoline and propane are stored on site for heating and power supply. All fuels are stored in approved storage containers. Diesel and gasoline are stored in covered area with containment device. All fertilizers, soil amendments, and pesticides used on site are stored indoors in approved containers. Bleach and alcohol are used on site to clean small hand tools typically these products would be stored in office areas in one-gallon bottles or smaller. Other household sanitizers may be used in kitchen and bathrooms. Small equipment and generator oil may be changed on site if said procedure will be completed over containment devices to prevent spillage.

Monitoring Plan

Cannabis cultivators shall regularly inspect and maintain the condition of access roads, access road drainage features, and watercourse crossings. At a minimum, cannabis cultivators shall perform inspections prior to the onset of fall and winter precipitation and following storm events that produce

at least 0.5 in/day or 1.0 inch/7 days of precipitation. Cannabis cultivators are required to perform all of the following maintenance:

- Remove any wood debris that may restrict flow in a culvert.
- Remove sediment that impacts access road or drainage feature performance.
- Place any removed sediment in a location outside the riparian setbacks and stabilize the sediment.
- Maintain records of access road and drainage feature maintenance for annual reporting.

Cannabis cultivator that are operating in areas that are, or may become, inaccessible during winter months due to extreme weather such as snow, road closures, seasonal access roads to the property, or any other such conditions shall make additional efforts to enhance winterization measures in the absence of monitoring during storm events.

Monitoring Requirements

(Tier 2, Low Risk, < 1 acre of cultivation)

Monitoring Requirement	Description
Winterization Measures Implemented	Report winterization procedures implemented, any outstanding measures, and the schedule for completion.
Tier Status Confirmation	Report any changes in the tier status.
Third Party Identification	Report any change in third party status as appropriate.

Annual Reporting

Annual Reports shall be submitted to the North Coast Regional Water Quality Control Board by March 1st following the year being monitored. The first Annual Report for this enrollment shall be submitted by March 1st, 2020 and report on monitoring done during the 2019 calendar year. Annual reporting is required each subsequent year of enrollment.

General Recommendations

- Frequent use of un-surfaced roads should be avoided, particularly when road surfaces are soft/saturated.

- Existing or newly installed road surface drainage structures such as water bars, rolling dips, ditch relief culverts, and intentionally in/out-sloped segments of road shall be maintained to ensure continued function of capturing and draining surface runoff.
- All culverts should be inspected regularly during the winter months to check for plugging, blockage, or other issues.
-
- All generators and petroleum powered pumps shall be located out of riparian setbacks, and are required to have spill trays or secondary containment placed underneath them when using, fueling, or changing oil on them to prevent the potential for leeching, seepage or spillage of petroleum products. All spill trays and containment structures require cover from precipitation. See BMPs: See BMPs: Generator, Fuel, Oil Management and General Recommendations - Petroleum products and hazardous materials specifications.
- Keep and use absorbent materials designated for spill containment and spill cleanup equipment on-site for use in an accidental spill of fertilizers, petroleum products, and hazardous materials.
- Fertilizer, soil amendments, and pesticide use it to be recorded in such a manner that cumulative annual totals are recorded for annual reporting.
- Store in-use fertilizers in a small storage container, such as a tote or deck box, adjacent to the mixing tanks. For the winter period, store fertilizers in enclosed structures with concrete or wooden floors. Do not store fertilizers and flammable petroleum fuels in the same storage structure or area.
- All water storage tanks shall be located out of riparian setbacks.
- Water use shall be designed and metered such that water used for the irrigation of cannabis will be recorded separately from domestic use. Water use for the irrigation of cannabis is to be recorded monthly for annual reporting.
- Install float valves, or implement another equivalent system, on all applicable water storage and transfer tanks to prevent unnecessary water diversion and the overflowing of water tanks.
- Ensure lids are secured on all water storage tanks to prevent wildlife from becoming entrapped within the tank.

Winterization

- Any exposed soils or disturbed land resulting from summer operations or winterization activities shall be seeded with native grass seed and mulched with weed free straw and/or wood chips.

- All disturbed ground and exposed soils around the pond will be treated with erosion control measures including: seeding with native grass seed, mulching with weed free straw and/or wood chips, and installing erosion control measures such as straw wattles, and jute netting.
- All existing culvert inlets shall be cleared of any potential obstructions.
- All fertilizers and petroleum products will be completely sealed and placed in the Storage Structures.
- The chemical toilet will be removed from the property until need resumes the following cultivation season.
- Water storage tank lids shall be appropriately closed to prevent the access of wildlife.
- All refuse/trash shall be removed and disposed of appropriately.
- All inorganic material capable of being transported by wind or rain shall be secured and stored appropriately.
- Any exposed soils resulting from winterization activities shall be seeded and straw mulched.

8. Appendix

8.1 Best Practical Treatment or Control Measures

BMP procedure measures to be implemented

- List of record keeping, monitoring, and other measures needed for compliance.
- Install flow meters for Install flow meters water use and record water use weekly.
- Use log pages and provide additional documentation as needed.
- Record water use.
- Read flow meters weekly and record irrigation use by water source.
- Use log pages provide additional documentation as needed.
- Wet weather road inspection.
- Inspect road during wet weather annually.
- Observe water and sediment discharge.
- Document observations, apply corrective measures to prevent erosion as needed based on observations.
- Pre and post season inspection, conduct self- assessment twice annually.
- Use log pages provide additional documentation as needed.
- Keep chemical storage and use logs
- List chemicals stored onsite and information about quantities used and frequency applied.
- Record annual fertilizer and amendment use.

Pre-season Self-Assessment (to be completed after March and before April 15 each year)

Person Reporting: _____

Date: _____

Yes No

All stockpiles, soil amendments, pesticides, and fertilizers have remained properly stored and/or contained and have not discharged from their storage/containment facility(ies).

Comments:

Yes No

Implemented erosion and sediment controls have remained in place and functioning throughout the winter wet weather period, preventing sediment and turbid stormwater from discharging to surface water bodies.

Comments:

Yes No

All access roads appear to be in good condition and drainage structures have been effective in preventing road surface and fill material from discharging to any surface water bodies.

Comments:

Yes No

Watercourse crossing structures remain functioning throughout the winter wet weather period and there is no evidence of crossings being plugged, overtopped, and/or discharging sediment or fill material. Comments:

Yes No

All water containment structures/ponds/dams have remained effective and in good condition.

Additional Findings: Please describe pre-winter BMPs applied to the site including location and methods (attach additional pages as necessary):

_____ **Comments:**

Post-Season Self-Assessment (to be completed by October 15th each year)

Person Reporting: _____

Date: _____

Yes N/A

All stockpiles, soil amendments, pesticides, and fertilizers have been properly stored and/or protected per Best Management Practices (BMPs).

Comments

Yes N/A

Erosion and sediment controls have been properly installed and are functioning, and all areas of exposed soil have been stabilized in preparation for the winter wet weather period. Comments

Yes N/A

Drainage structures (waterbars/rolling dips) have been installed and are functioning on all access roads, and all access roads intended for use during the winter wet weather period have been weatherproofed. Comments

Yes N/A

Watercourse crossing structures have been correctly installed/maintained, all fill material/exposed soil has been stabilized, and are free of debris that could plug crossings over the winter wet weather period. Comments

Yes N/A

All trash/refuse has been cleaned up where it cannot pass into or be transported into any water body and empty/used containers have been properly disposed per manufacturer's instructions. Comments

Yes N/A

All water containment/storage ponds/dams have been inspected and appear to be in good, stable condition.

Additional Findings/Comments:

8.3 Emergency Contact Information

Green With Envy, LLC shall visibly post and maintain an emergency contacts list which will include at a minimum:

- 1. Managerial and property owner contact(s):**
- 2. Property Owner/Manager- Matt Grace (310) 486-3635**
- 3. Emergency responder contact(s):**

- a. EMERGENCY CALL 911**

**Site Address: 5188 Burr Valley Rd. Dinsmore CA
95526**

- b. Nonemergency Sheriff: (707) 445-7251**

- 4. Hazardous Material/Poison control contact(s):**

- a. EMERGENCY CALL 911**

**Site Address: 5188 Burr Valley Rd. Dinsmore, CA
95526**

- b. Poison Control Centers 1-800-222-1222**

- c. Humboldt County HazMat: (707) 445-6215**

- d. Humboldt County Ag Dept: (707) 441-5260**

BMP: Winterization and Interim Treatments for Erosion Control

• Roads

- Existing or newly installed road surface drainage structures such as water bars, rolling dips, ditch relief culverts, and intentionally in/out-sloped segments of road shall be maintained to ensure continued function of capturing and draining surface runoff.
- Hand tool kick-outs (lead out ditch) for existing wheel rut, surface run-off confinement.
- Temporary waterbar/cross-wattles installed on road/trail sections of concentrating surface runoff.
- Clean existing DRC inlets, outlets, and contributing ditch lines of current and potential blockage debris by hand.
- Hand place energy dissipating rock/small woody debris at DRC outlets where erosion is occurring.
- Wattles/straw bales placed at road runoff delivery sites.
- Touch-up with hand tools of existing surface drainage structures (kick-outs, rolling dips, and waterbars).
- Seed and straw un-used, or to be abandoned, road surfaces where erosion is occurring.
- Frequent use of un-surfaced roads should be avoided, particularly when road surfaces are soft/saturated.

• Crossings

- Clean inlets, outlets, and channels above of current and potential blockage debris by hand.
- Hand place energy dissipating rock/SWD at DRC outlets.
- Hand placement of rock armor around culvert inlets.
- Installation of wattles along the outboard road edge of out-sloped crossing with direct delivery of road surface runoff is occurring.
- Hand placement of rock on crossing fill faces where erosion is/may occur as a result of poor crossing construction.

• Cultivation Areas

- Use hand tools to capture cultivation related soils that are not contained (soil from post-harvest plant removal, soil/planter removal, general spillage).
- Treat beds, pots, new soil storage piles, spent soil piles, and soil disposal piles with cover crops for soil stability and potentially nitrogen fixing/soil amendment.
- Bagged potting soil should be covered.
- Install staked wattles or an earthen berm around cultivation soils piles prior to the winter period, annually.
- Any soil amendment, fertilizer, herbicide, or pesticide that is not 100% sealed should be stored under cover.
- Cultivation sites with poor or concentrating drainage can have wattles or bales installed prior to winter to help prevent sediment and nutrients from leaving the site.
- Plastic netting shall be disposed of or stored where it is inaccessible to wildlife.
- Tarps/dep covers shall be stored so they cannot be blown away.
- General waste from growing season gathered up and disposed of.
- Exposed soil surfaces in the cultivation area, as well as graded fill slopes should be seeded, strawed, mulched, jute netted as needed.

• General Areas

- Remove all refuse prior to leaving property for the season.
- Back fill pit toilets to be abandoned.

BMP: General Recommendations

- **Fertilizers, soil amendments, and pesticides**
 - Fertilizer, soil amendments, and pesticide use it to be recorded in such a manner that cumulative annual totals are recorded for annual reporting.
 - Store in-use fertilizers in a securable storage container, such as a tote or deck box, adjacent to the mixing tanks.

- **Petroleum products and hazardous materials**
 - Utilize spill trays/containment structures and cover over the containment when using, fueling, changing oil on portable generators or petroleum powered water pumps to prevent the potential for leeching, seepage or spillage of petroleum products.
 - It is recommended that all petroleum products and other chemicals are registered with the California Environmental Reporting System (CERS) to satisfy future licensing requirements.

- **Water storage and Use**
 - Water use shall be designed and metered such that water used for the irrigation of cannabis will be recorded separately from domestic use. Water use for the irrigation of cannabis is to be recorded monthly for annual reporting.
 - Ensure lids are secured on all water storage tanks to prevent wildlife from becoming entrapped within the tank.
 - Install float valves, or implement another equivalent system, on all applicable water storage and transfer tanks to prevent unnecessary water diversion and the overflowing of water tanks.

BMP: General Operations BMPs

- If operations require moving of equipment across a flowing stream, such operations shall be conducted without causing a prolonged visible increase in stream turbidity. For repeated crossings, the operator shall install a bridge, culvert, or rock-lined crossing.
- During construction in flowing water, which can transport sediment downstream, the flow shall be diverted around the work area by pipe, pumping, temporary diversion channel or other suitable means. When any dam or artificial obstruction is being constructed, maintained, or placed in operation, sufficient water shall at all times be allowed to pass downstream to maintain fish life below the dam. Equipment may be operated in the channel of flowing live streams only as necessary to construct the described construction.
- Disturbance or removal of vegetation shall not exceed the minimum necessary to complete operations. The disturbed portion of any stream channel shall be restored to as near their original condition as possible. Restoration shall include the mulching of stripped or exposed dirt areas at crossing sites prior to the end of the work period.
- Structures and associated materials not designed to withstand high seasonal flow shall be removed to areas above the high-water mark before such flows occur.
- No debris, soil, silt, sand, bark, slash, sawdust, rubbish, cement or concrete washing, oil or petroleum products, or other organic or earthen material from any logging, construction, or associated activity of whatever nature shall be allowed to enter into or be placed where it may be washed by rainfall or runoff into waters of the State. When operations are completed, any excess materials or debris shall be removed from the work area. No rubbish shall be deposited within 150 feet of the high-water mark of any stream.

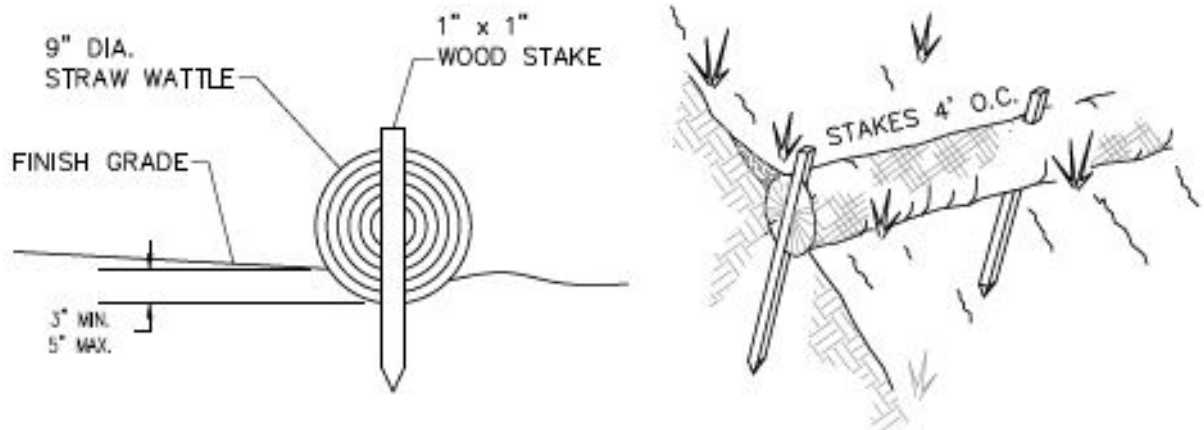
BMP: General Erosion Control

- Timing for soil stabilization measures within the 100 feet of a watercourse or lake: For areas disturbed from May 1 through October 15, treatment shall be completed prior to the start of any rain that causes overland flow across or along the disturbed surface. For areas disturbed from October 16 through April 30, treatment shall be completed prior to any day for which a chance of rain of 30 percent or greater is forecast by the National Weather Service or within 10 days, whichever is earlier.
- Within 100 feet of a watercourse or lake, the traveled surface of logging roads shall be treated to prevent waterborne transport of sediment and concentration of runoff that results from operations. Treatment may consist of, but not limited to, rocking, out sloping, rolling dips, cross drains, water bars, slope stabilization measures, or other practices appropriate to site-specific conditions.
- The treatment for other disturbed areas within 100 feet of a watercourse or lake, including: (A) areas exceeding 100 contiguous square feet where operations have exposed bare soil, (B) approaches to road watercourse crossings out to 100 feet or the nearest drainage facility, whichever is farthest, (C) road cut banks and fills, and (D) any other area of disturbed soil that threatens to discharge sediment into waters in amounts deleterious to the quality and beneficial uses of water, shall be grass seeded and mulched with straw or fine slash. Grass seed shall be applied at a rate exceeding 100 pounds per acre. Straw mulch shall be applied in amounts sufficient to provide at least 2- 4-inch depth of straw with minimum 90% coverage. Slash may be substituted for straw mulch provided the depth, texture, and ground contact are equivalent to at least 2 – 4 inches of straw mulch. Any treated area that has been subject to reuse or has less than 90% surface cover shall be treated again prior to the end of operations.
- Within 100 feet of a watercourse or lake, where the undisturbed natural ground cover cannot effectively protect beneficial uses of water from operations, the ground shall be treated with slope stabilization measures described in #3 above per timing described in #1 above.
- Side cast or fill material extending more than 20 feet in slope distance from the outside edge of a landing which has access to a watercourse or lake shall be treated with slope stabilization measures described in #3 above. Timing shall occur per #1 above unless outside 100 feet of a watercourse or lake, in which completion date is October 15.
- All roads shall have drainage and/or drainage collection and storage facilities installed as soon as practical following operations and prior to either (1) the start of any rain which causes overland flow across or along the disturbed surface within 100 feet of a watercourse or lake protection, or (2) any day with a National Weather Service forecast of a chance of rain of 30 percent or more, a flash flood warning, or a flash flood watch.

BMP: General Erosion Control (Cont.)

- Erosion control and sediment detention devices and materials shall be incorporated into the cleanup/restoration work design and installed prior to the end of project work and before the beginning of the rainy season. Any continuing, approved project work conducted after October 15 shall have erosion control works completed up-to-date and daily.
- Erosion control materials shall be, at minimum, stored on-site at all times during approved project work between May 1 and October 15.
- Approved project work within the 5-year flood plain shall not begin until all temporary erosion controls (straw bales or silt fences that are effectively keyed-in) are installed downslope of cleanup/restoration activities.
- Non-invasive, non-persistent grass species (e.g., barley grass) may be used for their temporary erosion control benefits to stabilize disturbed slopes and prevent exposure of disturbed soils to rainfall.
- Upon work completion, all exposed soil present in and around the cleanup/restoration sites shall be stabilized within 7 days.
- Soils exposed by cleanup/restoration operations shall be seeded and mulched to prevent sediment runoff and transport.
- Straw Wattles (if used) shall be installed with 18 or 24-inch wood stakes at four feet on center. The ends of adjacent straw wattles shall be abutted to each other snugly or overlapped by six inches. Wattles shall be installed so that the wattle is in firm contact with the ground surface.

BMP: General Erosion Control (Cont.)

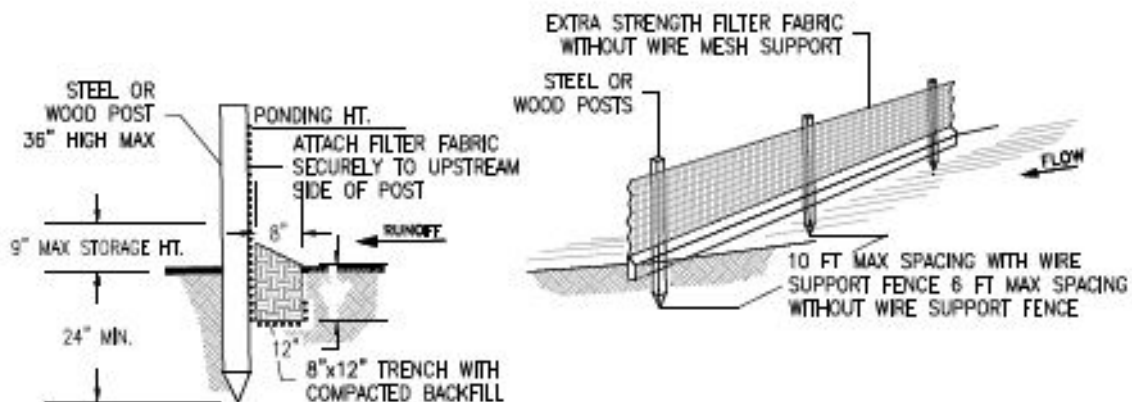


STRAW WATTLE NOTES:

1. STRAW WATTLES SHALL BE INSTALLED WITH 18 OR 24 INCH WOOD STAKES AT FOUR FEET ON CENTER. THE ENDS OF ADJACENT STRAW WATTLES SHALL BE ABUTTED TO EACH OTHER SNUGLY OR OVERLAPPED BY SIX INCHES.
2. STRAW ROLL INSTALLATION REQUIRES THE PLACEMENT AND SECURE STAKING OF THE ROLL IN A TRENCH, 3"-5" DEEP. RUNOFF MUST NOT BE ALLOWED TO RUN UNDER OR AROUND THE ROLL.

STRAW WATTLE INSTALLATION DETAIL

NTS



SILT FENCE NOTES:

1. THE CONTRACTOR SHALL INSPECT AND REPAIR FENCE AFTER EACH STORM EVENT.
2. CONTRACTOR SHALL REMOVE SEDIMENT AS NECESSARY. REMOVED SEDIMENT SHALL BE DEPOSITED TO AN AREA THAT WILL NOT CONTRIBUTE SEDIMENT OFF-SITE AND IN AN AREA THAT CAN BE PERMANENTLY STABILIZED.
3. SILT FENCE SHALL BE PLACED ON SLOPE CONTOURS TO MAXIMIZE PONDING EFFICIENCY.

SILT FENCE DETAILS

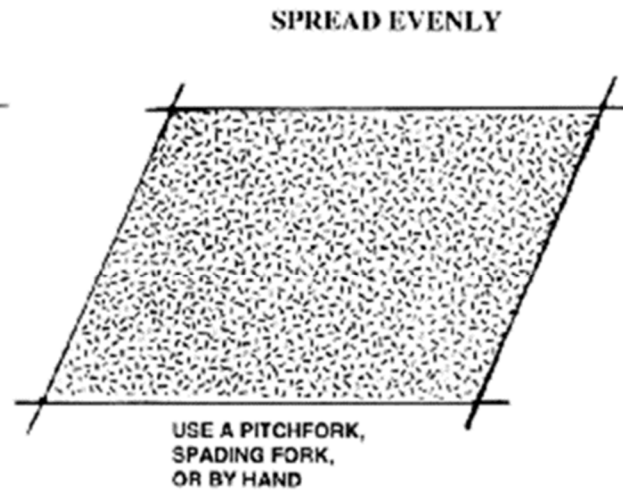
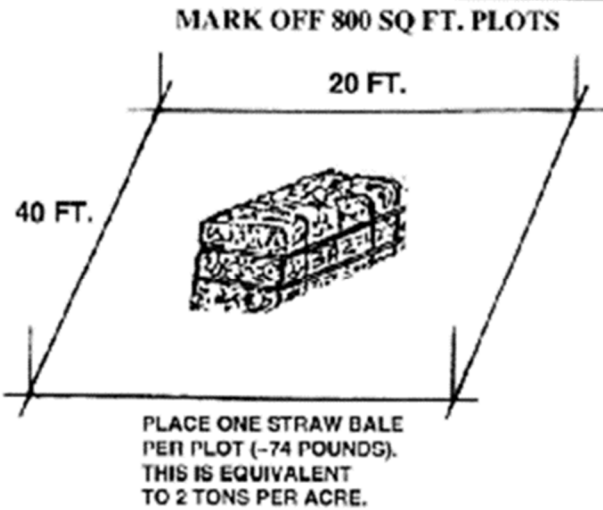
NTS

BMP: General Erosion Control (Cont.)

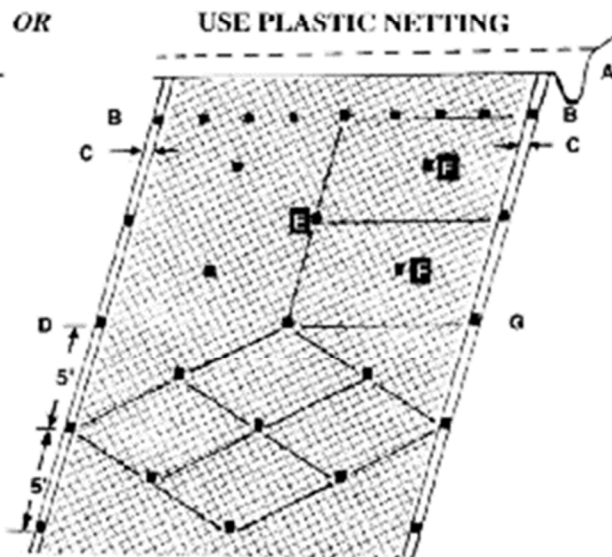
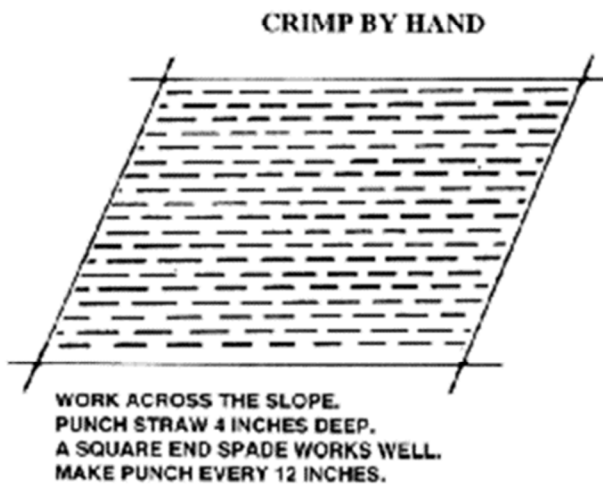


BMP: General Erosion Control (Cont.)

SPREAD THE STRAW



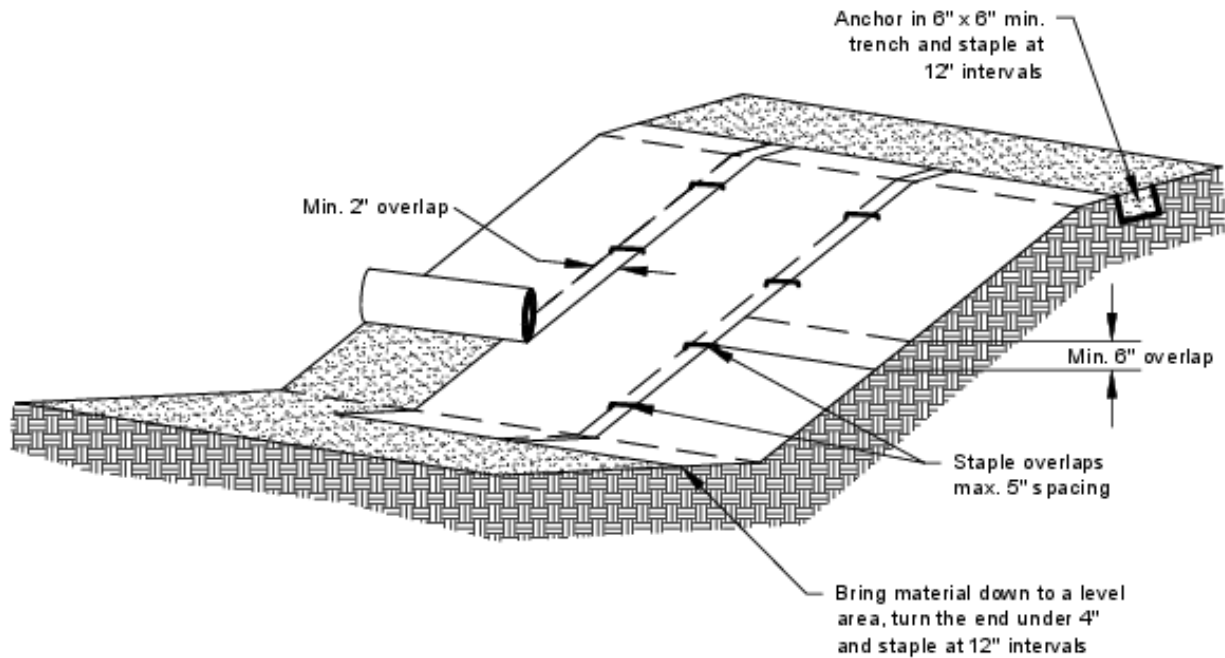
ANCHOR THE STRAW



- A. LAY BIRD CONTROL NETTING OR SIMILAR MATTING IN STRIPS DOWN THE SLOPE OVER THE STRAW. BURY UPPER END IN 6-8 INCH DEEP AND WIDE TRENCH.. MOST NETTING COMES IN 14 TO 17 FT. WIDE ROLLS.
- B. SECURE THE UPPER END WITH STAKES EVERY 2 FEET.
- C. OVERLAP SEAMS ON EACH SIDE 4-5 INCHES.
- D. SECURE SEAMS WITH STAKES EVERY 5 FEET.
- E. STAKE DOWN THE CENTER EVERY 5 FEET.

- F. STAKE MIDDLES TO CREATE DIAMOND PAT TERN THAT PROVIDES STAKES SPACED 4-5 FEET APART.
 - G. USE POINTED 1X2 INCH STAKES 8 TO 9 INCHES LONG. LEAVE 1 TO 2 INCH TOP ABOVE NETTING, OR USE "U" SHAPED METAL PINS AT LEAST 9 INCHES LONG.
- NOTE: WHEN JOINING TWO STRIPS, OVERLAP UPPER STRIP 3 FEET OVER LOWER STRIP AND SECURE WITH STAKES EVERY 2 FEET LIKE IN "B" ABOVE

BMP: General Erosion Control (Cont.)



Notes:

1. Slope surface shall be smooth before placement for proper soil contact.
2. Stapling pattern as per manufacturer's recommendations.
3. Do not stretch blankets/matting tight - allow the rolls to mold to any irregularities.
4. For slopes less than 3H:1V, rolls may be placed in horizontal strips.
5. If there is a berm at the top of the slope, anchor upslope of the berm.
6. Lime, fertilize, and seed before installation. Planting of shrubs, trees, etc. should occur after installation.

NOT TO SCALE



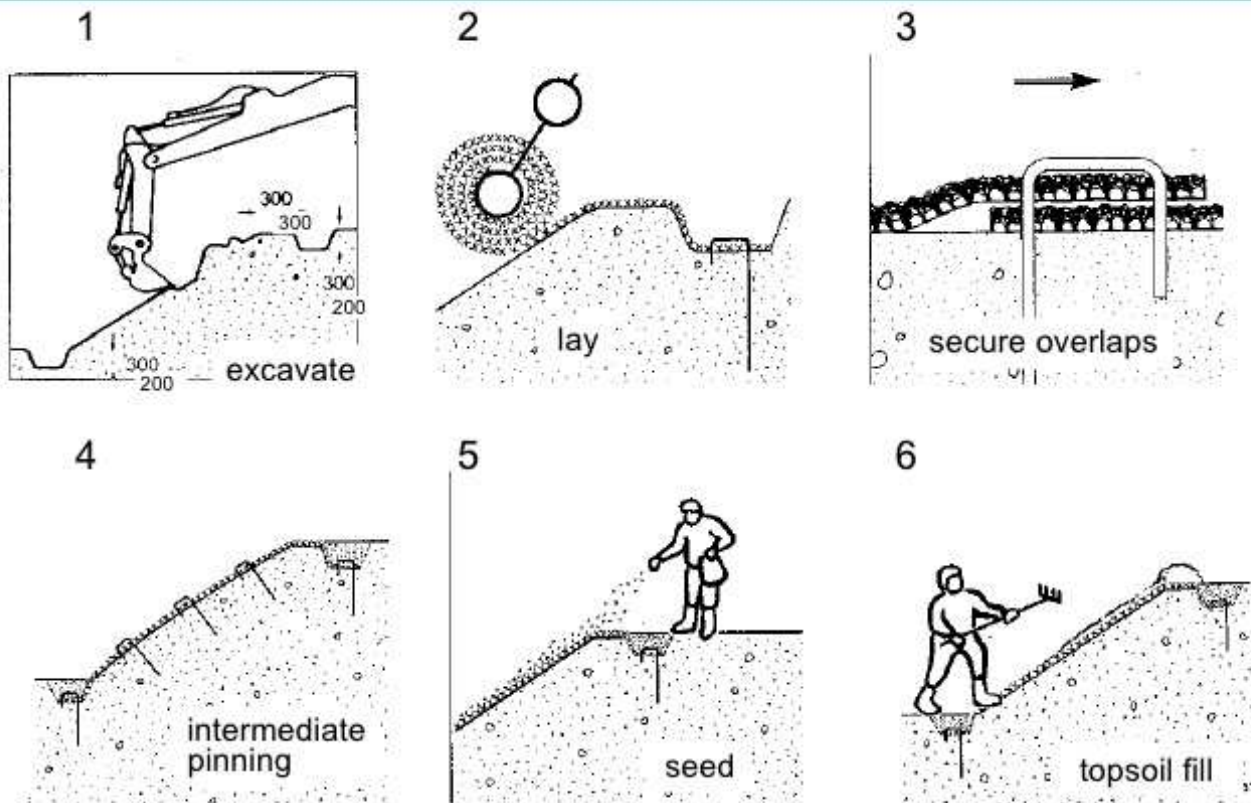
DEPARTMENT OF
ECOLOGY
State of Washington

Slope Installation

Revised June 2018

Please see <http://www.ecy.wa.gov/copyright.html> for copyright notice including permissions, limitation of liability, and disclaimer.

Installation of a geosynthetics mat - Enkamat



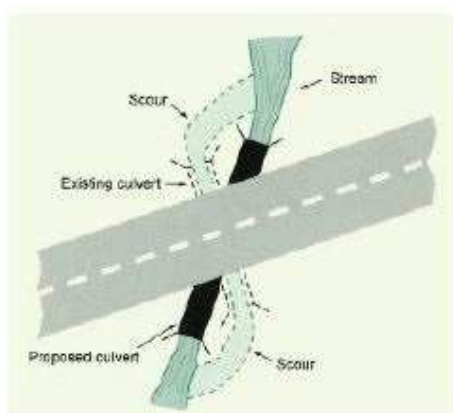
BMP: General Erosion Control (Cont.)

TABLE 34. Guidelines for erosion and sediment control application

Timing of application	Technique	Portion of road and construction area treated
Erosion control during construction	Hydromulching, hydroseeding	Road fill slopes, cut slopes, bare soil areas
	Dry seeding	Road fill slopes, cut slopes, bare soil areas
	Wood chip, straw, Excelsior or tackified mulch	Road fill slopes, cut slopes, bare soil areas
	Straw wattles	Road fill slopes and cut slopes
	Gravel surfacing	Road, landing and turnout surfaces
	Dust palliative	Road surfaces
	Minimize disturbance (soil and vegetation)	All areas peripheral to construction
Sediment control during construction	Sediment basin	Roadside ditches, turnouts and small stream crossings
	Sediment traps (e.g., silt fences, straw bales barriers, woody debris barriers)	Road fill slopes, cutbanks, bare soil areas and ditches
	Straw bale dams	Ditches and small streams
	Sumps and water pumps	Stream channels and stream crossings
	Streamflow diversions (e.g., temporary culverts, flex pipe, etc.)	Stream channels and stream crossings
	Surface diversion and dispersion devices (pipes, ditches, etc.)	All disturbed bare soil areas
Permanent erosion control	Road shaping	Road and landing surfaces
	Gravel surfacing	Road, landing and turnout surfaces
	Bituminous or asphalt surfacing	Road surface
	Rolling dips	Road surface
	Ditch relief culverts	Roadbed and road fill
	Downspouts and berm drains	Road fill slopes
	Waterbars	Road and landing surfaces
	Berms	Road surface and roadside areas
	Ditches	Road and landing surfaces
	Riprap	Road fill slopes, stream crossing fills, cutbanks, stream and lake banks
	Soil bioengineering	Road fill slopes, cut slopes, stream crossings, streambanks
Tree planting	Road fill slopes, cutbanks, bare soil areas, stream crossings, streambanks	

BMP: Permanent Culvert Crossing

- New culvert installations shall be sized to accommodate flows associated with a 100-year storm event.
- If the new culvert is replacing a poorly installed old culvert, the crossing may need to be abandoned to the following standard:
 - When fills are removed they shall be excavated to form a channel that is as close as feasible to natural watercourse grade and orientation, and that is wider than the natural channel.
 - Excavated banks shall be laid back to a 2:1 (50%) or natural slope.
- New culverts shall be placed at stream gradient, or have downspouts, or have energy dissipaters at outfall.
 - Align culverts with the natural stream channel orientation to ensure proper function, prevent bank erosion, and minimize debris plugging. See Figure 97 below.
 - Place culverts at the base of the fill and at the grade of the original streambed or install a downspout past the base of the fill. Downspouts should only be installed if there are no other options.
 - Culverts should be set slightly below the original stream grade so that the water drops several inches as it enters the pipe.
 - Culvert beds should be composed of rock-free soil or gravel, evenly distributed under the length of the pipe.
 - Compact the base and sidewall material before placing the pipe in its bed.
 - Lay the pipe on a well-compacted base. Poor basal compaction will cause settling or deflection in the pipe and can result in separation at a coupling or rupture in the pipe wall.
 - Backfill material should be free of rocks, limbs, or other debris that could dent or puncture the pipe or allow water to seep around the pipe.
 - Cover one end of the culvert pipe, then the other end. Once the ends are secure, cover the center.
 - Tamp and compact backfill material throughout the entire process, using water as necessary for compaction.
 - Backfill compacting will be done in 0.5 – 1.0 foot lifts until 1/3 of the diameter of the culvert has been covered.
 - Push layers of fill over the crossing to achieve the final design road grade, road fill above the culvert should be no less than one-third to one-half the culvert diameter at any point on the drivable surface.
- Critical dips shall be installed on culvert crossings to eliminate diversion potential. Refer to Figure 84 below.
- Road approaches to crossings shall be treated out to the first drainage structure (i.e. waterbar, rolling dip, or hydrologic divide) to prevent transport of sediment.
- Road surfaces and ditches shall be disconnected from streams and stream crossings to the greatest extent feasible. Ditches and road surfaces that cannot be feasibly disconnected from streams or stream crossings shall be treated to reduce sediment transport to streams.
- If downspouts are used, they shall be secured to the culvert outlet and shall be secure on fill slopes.
- Culverts shall be long enough so that road fill does not extend or slough past the culvert ends.
- Inlet of culverts, and associate fill, shall be protected with appropriate measures that extend at least as high as the top of the culvert.
- Outlet of culverts shall be armored with rock if road fill sloughing into channel can occur.
- Armor inlets and outlets with rock, or mulch and seed with grass as needed (not all stream crossings need to be armored).
- Where debris loads could endanger the crossing, a debris catchment structure shall be constructed upstream of the culvert inlet.
- Bank and channel armoring may occur, when appropriate, to provide channel and bank stabilization.



HANDBOOK FOR FOREST, RANCH AND RURAL ROADS

FIGURE 97. Culvert alignment should be in relation to the stream and not the road. It is important that the stream enters and leaves the culvert in a relatively straight horizontal alignment so streamflow does not have to turn to enter the inlet or discharge into a bank as it exits. This figure shows a redesigned culvert installation that replaces the bending alignment that previously existed. Channel turns at the inlet increase plugging potential because wood going through the turn will not align with the inlet. Similarly, channel turns at the inlet and outlet are often accompanied by scour against the channel banks (Wisconsin Transportation Information Center, 2004).

BMP: Permanent Culvert Crossing Design (Critical Dip and Hydrologic Disconnect Placement)

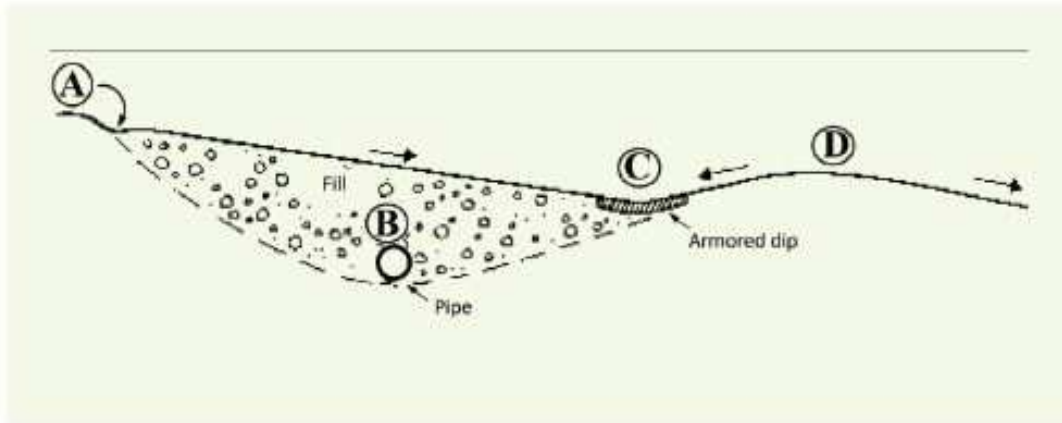
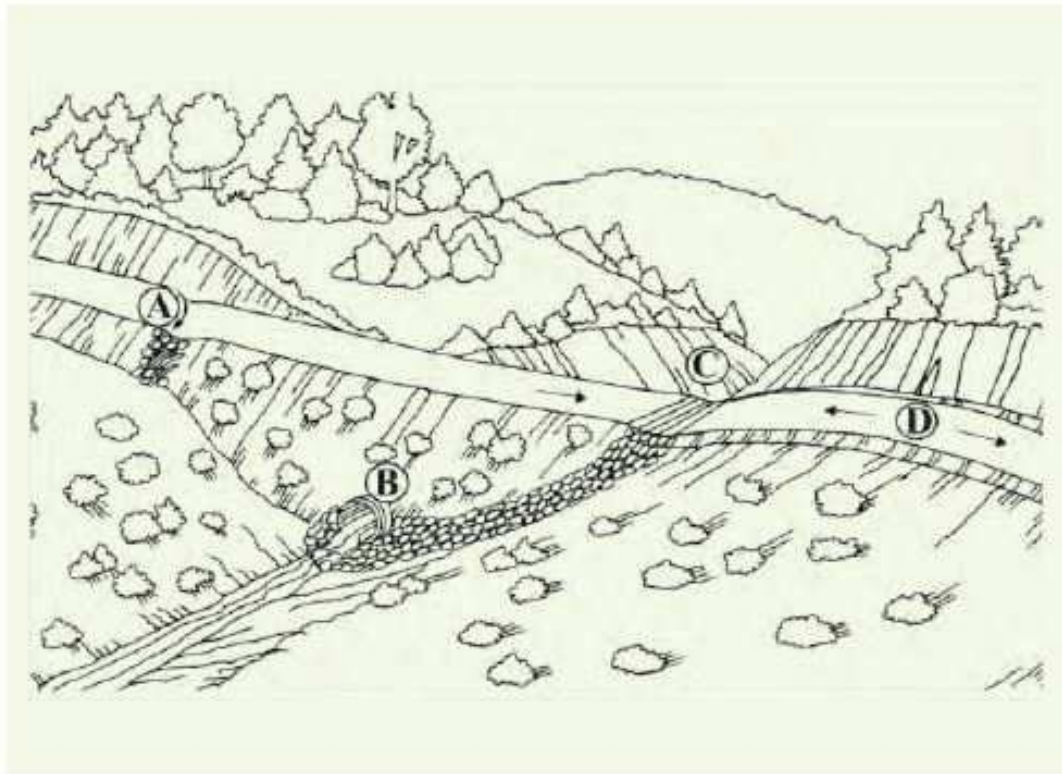
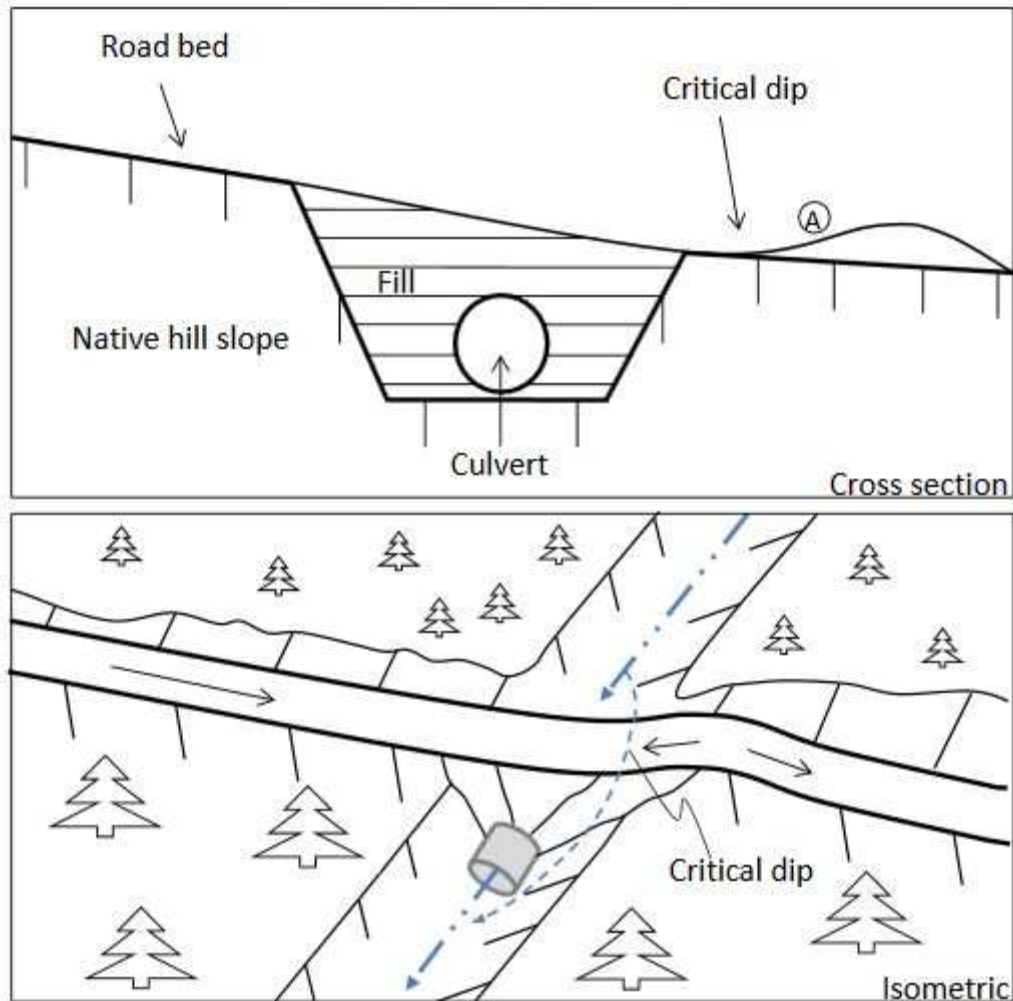


FIGURE 84. *Critical dips or dipped crossing fills should be centered near a stream crossing's down-road hinge line, not over the centerline of the crossing where overtopping could cause washout or severe erosion of the fill. If the stream crossing culvert (B) plugs, water will pond behind the fill until reaching the critical dip or low point in the crossing (C) and flowing back down into the natural stream channel. The down-road ditch must be plugged to prevent streamflow from diverting down the ditch line. For extra protection in this sketch, riprap armor has been placed at the critical dip outfall and extending downslope to the stream channel. This is only required or suggested on stream crossings where the culvert is highly likely to plug and the crossing fill overtopped. The dip at the hinge line is usually sufficient to limit erosional damage during an overtopping event. Road surface and ditch runoff is disconnected from the stream crossing by installing a rolling dip and ditch relief culvert just up-road from the crossing (A) (Keller and Sherar, 2003).*

BMP: Permanent Culvert Crossing Design (Critical Dip)

Typical Critical Dip Design for Stream Crossings with Diversion Potential



Critical Dip Construction:

1. Critical dip will be constructed on the lower side of crossing.
2. Critical dip will extend from the cutbank to the outside edge of the road surface. Be sure to fill inboard ditch, if present.
3. Critical dip will have a reverse grade (A) from cutbank to outside edge of road to ensure flow will not divert outside of crossing.
4. The rise in the reverse grade will be carried for about 10 to 20 feet and then return to original slope.
5. The transition from axis of bottom, through rising grade, to falling grade, will be in the road distance of at least 15 to 30 feet.
6. Critical dips are usually built perpendicular to the road surface to ensure that flow is directed back into the stream channel.

BMP: Permanent Culvert Crossing Design (Culvert Orientation)

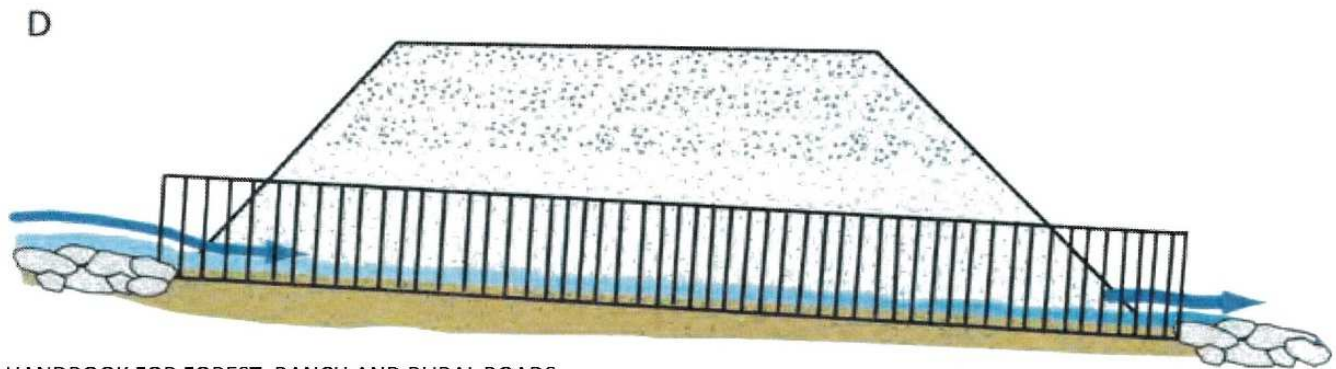
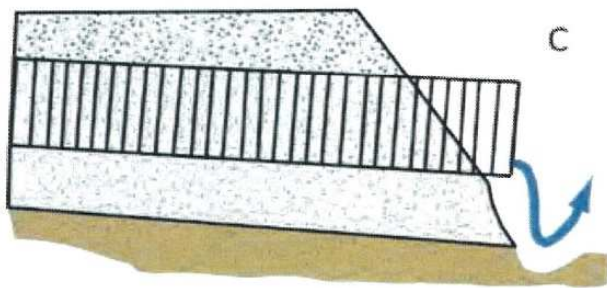
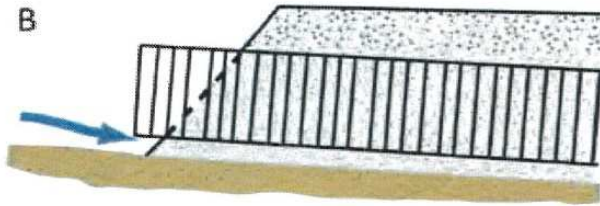
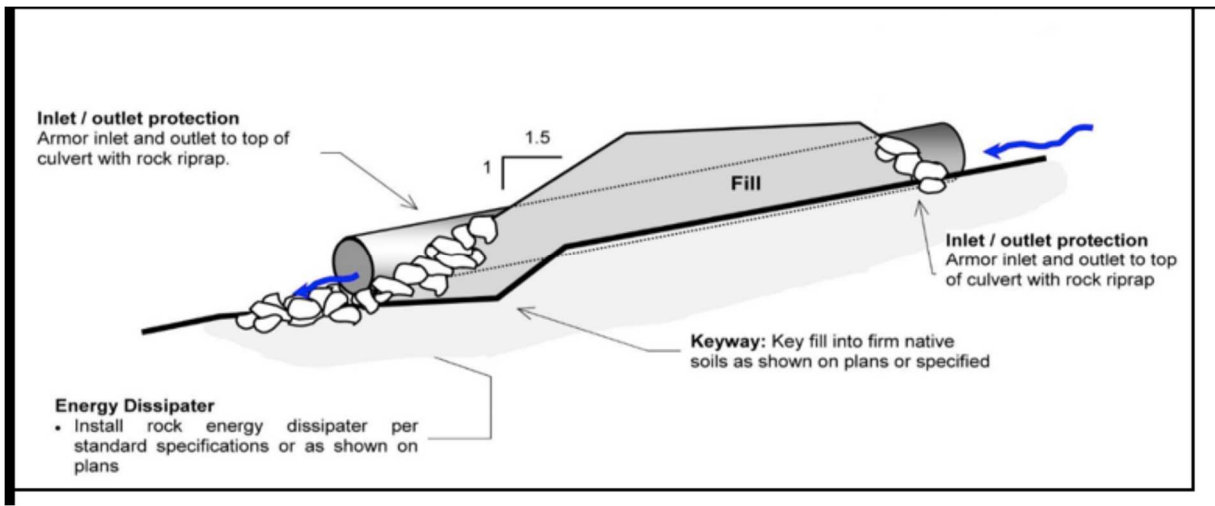
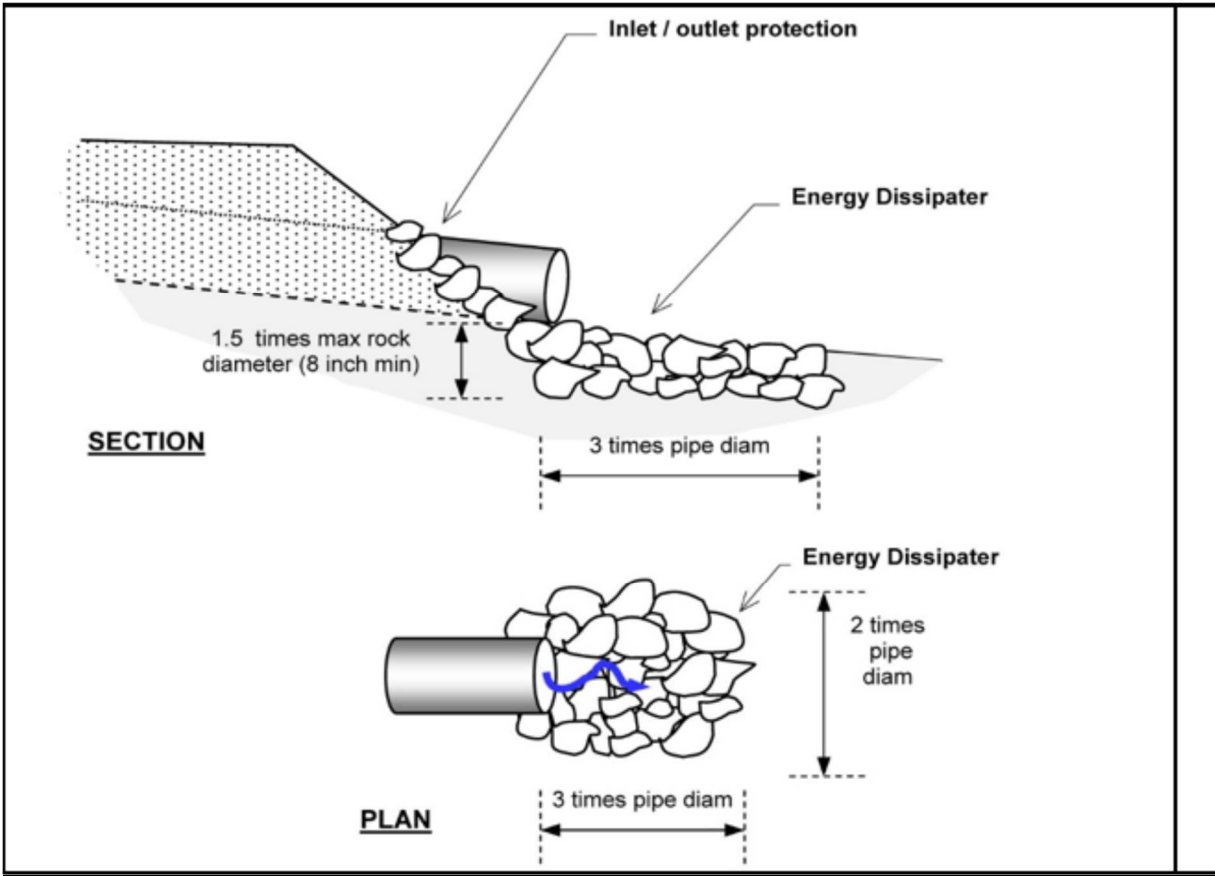


FIGURE 155. Proper culvert installation involves correct culvert orientation, setting the pipe slightly below the bed of the original stream, and backfilling and compacting the fill as it is placed over the culvert. Installing the inlet too low in the stream (A) can lead to culvert plugging, yet if set too high (B) flow can undercut the inlet. If the culvert is placed too high in the fill (C), flow at the outfall will erode the fill. Placed correctly (D), the culvert is set slightly below the original stream grade and protected with armor at the inlet and outlet. Culverts installed in fish-bearing stream channels must be inset into the streambed sufficiently (>25% embedded) to have a natural gravel bottom throughout the culvert (Modified from: MDSL, 1991).

BMP: Permanent Culvert Crossing Design (Inlet and Outlet Armoring)



Riprap installed to protect the inlet and outlet of a stream crossing culvert from erosion or for energy dissipation should be keyed into the natural channel bed and banks to an approximate depth of about 1.5x the maximum rock thickness. Riprap should be placed at least up to the top of the culvert at both the inlet and outlet to protect them from splash erosion and to trap any sediment eroded from the newly constructed fill slope above.

BMP: Permanent Culvert Crossing Design (Inlet and Outlet Armoring) Cont.

- Inlets of culverts and associate fills shall be protected with rock armoring that extends at least as high as the top of the culvert.
- Outlets of culverts shall be provided a rock energy dissipater at the outfall of the culvert.
- Outlets of culverts and associate fills shall be protected with rock armoring that extends at least as high as the top of the culvert if road fill sloughing into channel can occur.
- Prior to inlet and outlet rocking, the inlet and outlets shall be prepared. Preparation will include removal of vegetation and stored materials from the inlet and outlet.
- Inlets may require construction of an inlet basin.
- Slopes at the outlet should be shaped to a 2:1 or natural slope prior to placing rock armor.
- Rock used at culvert inlets and outlets should be a matrix of various sized rocks and rip-rap that range from a 3" dia. to a 2' dia.
- The largest rocks should be places at the base of the culvert or fill. Incrementally smaller rocks shall be placed over the larger rocks at the armoring extend up the slope. Voids and spaces shall be back filled with smaller gravels and rocks.

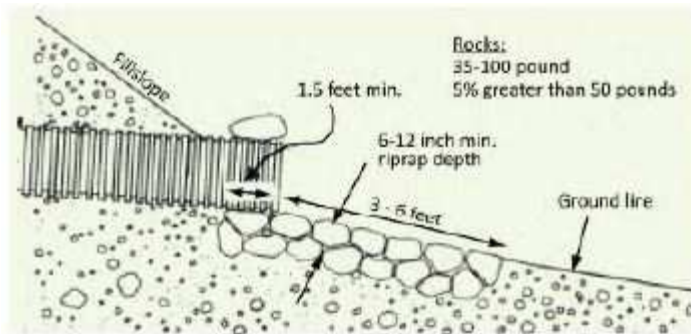


FIGURE 107A. Riprap armor at culvert outlet (Modified from: Keller et al., 2011).

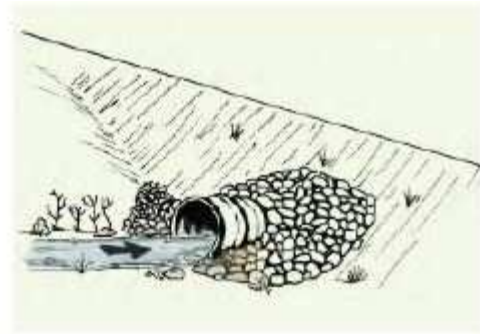


FIGURE 107B. Riprap armor at culvert inlet (Keller and Sherar, 2003).

HANDBOOK FOR FOREST, RANCH AND RURAL ROADS

BMP: Stream Bank Armoring (Riprap)

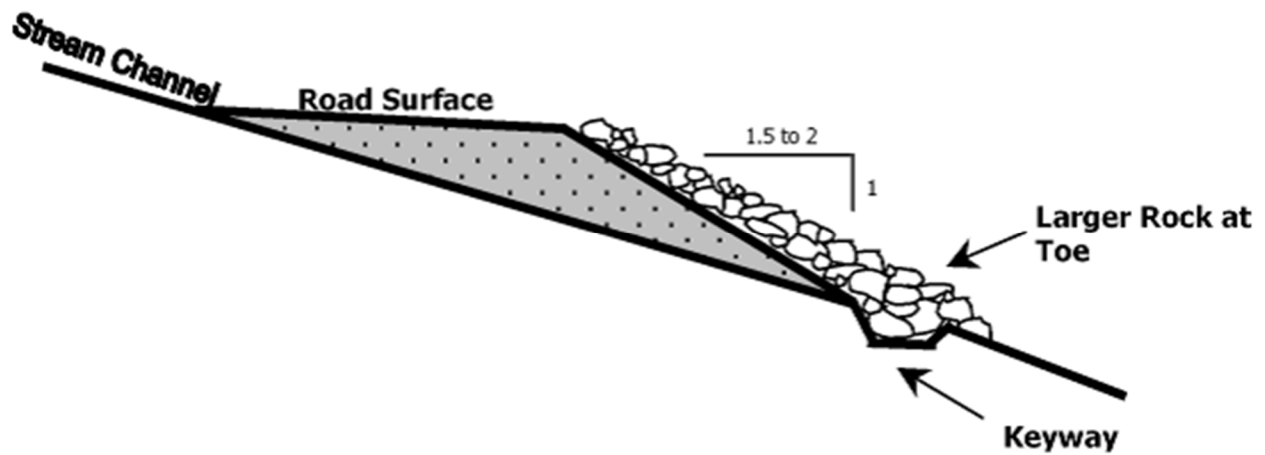
- Riprap should be installed on top of geotextile fabric or a clean mixture of coarse gravel and sand.
- The riprap should be keyed into the streambed and extend below the maximum expected scour depth with an adequately sized key base width at a thickness of a minimum of 2x the median (D50) rock diameter with the largest stone sizes placed at the base of the riprap structure.
- The armor should be set into the streambank so it does not significantly protrude into, or constrict, the natural channel, or otherwise reduce channel capacity.
- The riprap should extend along the length of unstable or over steepened bank and up the bank sufficiently to encompass the existing bank instability and/or design flood elevations.

BMP: Rocked Ford

- Rocked fords are drainage structures designed to carry watercourses across roads where culvert crossings are not feasible or un-necessary.
- In channel constructed fords shall be of appropriate material that shall withstand erosion by expected velocities and placed in a U-shaped channel to create a drivable crossing.
 - The road shall dip into and out of the rocked ford to minimize diversion potential. Construct a broad rolling dip across the roadbed, centered at the crossing, which is large enough to contain the expected 100-yr flood discharge while preventing flood flow from diverting down the road or around the rock armor.
- The road surface at the ford shall be constructed with clean rock. The rock shall be applied to a minimum depth of 6 inches.
 - A range of interlocking rock armor sizes should be selected and sized so that peak flows will not pluck or transport the armor off the roadbed or the sloping fill face of the armored fill.
- The ford's outlet shall be rock armored to resist downcutting and erosion.
 - *Excavate the keyway and armored area* - Excavate a two to three-foot-deep "bed" into the dipped road surface and adjacent fillslope (to place the rock in) that extends from approximately the middle of the road, across the outer half of the road, and down the outboard road fill to where the base of the fill meets the natural channel. At the base of the fill, excavate a keyway trench extending across the channel bed.
 - *Armor the basal keyway* - Put aside the largest rock armoring to create the buttresses. Use the largest rock armor to fill the basal trench and create a buttress at the base of the fill. This should have a "U" shape to it and it will define the outlet where flow leaves the armored fill and enters the natural channel.
 - *Armor the fill* - Backfill the fill face with the remaining rock armor making sure the final armor is unsorted and well placed, the armor is two coarse-rock layers in thickness, and the armored area on the fill face also has a "U" shape that will accommodate the largest expected flow.
 - *Armor the top of the fill* - Install a second trenched buttress for large rock at the break-in-slope between the outboard road edge and the top of the fill face.
- If water is expected during the time of use, an adequately sized pipe shall be installed to handle the flow if present (min. 6 inch).
 - The pipe shall be laid over the rocked ford surface.
 - The inlet should be at grade with the upstream flow.
 - The outlet shall drain onto the outlet armoring of the rocked ford.
 - A layer of clean rock/gravel shall be installed over the pipe to establish the running surface of the truck road.
 - Following use, the temporary pipe shall be removed and the placed rock/gravel shall be graded out of the ford and used on the approaches.
 - No significant alteration to the bed and bank of the stream shall occur.
- Road approaches to rocked fords shall be rock surfaced out to the first drainage structure (i.e. waterbar) or hydrologic divide to prevent transport of sediment using rock.
- Bank and channel armoring may occur when appropriate to provide channel and bank stabilization.
- Road approach rock and rock ford armoring shall be reapplied following use as needed to maintain a permanent crossing.

BMP: Rocked Ford (Cont.)

FORD: A large dip is graded into the road at the axis of the stream channel. The outside fill face is dished out to form a spillway with large rock. On large watercourses, rock is keyed several feet into firm native soils. The road surface is rocked with 6" of minus rock.



BMP: Armored Ford [Fill]

- Armored fords are drainage structures designed to carry watercourses across roads.
- Armored fords shall have a U-shaped channel to create a drivable crossing.
 - The road shall dip into and out of the armored ford to minimize diversion potential. Construct a broad rolling dip across the roadbed, centered at the crossing, which is large enough to contain the expected 100-yr flood discharge while preventing flood flow from diverting down the road or around the rock armor.
- The road surface at the armored ford shall utilize native soils.
- The ford's inlet shall be rock armored if a threat of head cutting exists.
 - *Excavate the keyway* - Excavate a one to three-foot-deep "bed" into the inboard edge of the road
 - *Armor the basal keyway* – place various sized rock in the constructed keyway to prevent head cutting. Use the largest rock armor to fill the keyway trench and create a buttress along the inboard edge of the road. This should have a "U" shape to it and it will define the inlet where flow leaves the natural channel and enters the road.
- The ford's outlet shall be rock armored to resist downcutting and erosion.
 - *Excavate the keyway and armored area* - Excavate a two to three-foot-deep "bed" into the dipped road surface and adjacent fillslope (to place the rock in) that extends from approximately the middle of the road, across the outer half of the road, and down the outboard road fill to where the base of the fill meets the natural channel. At the base of the fill, excavate a keyway trench extending across the channel bed.
 - *Armor the basal keyway* - Put aside the largest rock armoring to create the buttresses. Use the largest rock armor to fill the basal trench and create a buttress at the base of the fill. This should have a "U" shape to it and it will define the outlet where flow leaves the armored fill and enters the natural channel.
 - *Armor the fill* - Backfill the fill face with the remaining rock armor making sure the final armor is unsorted and well placed, the armor is two coarse-rock layers in thickness, and the armored area on the fill face also has a "U" shape that will accommodate the largest expected flow.
 - *Armor the top of the fill* - Install a second trenched buttress for large rock at the break-in-slope between the outboard road edge and the top of the fill face.
- If water is expected during the time of use, an adequately sized pipe shall be installed to handle the flow if present (min. 6 inch).
 - The pipe shall be laid over the armored ford surface.
 - The inlet should be at grade with the upstream flow.
 - The outlet shall drain onto the outlet armoring of the rock armored ford.
 - A layer of clean native shall be installed over the pipe to establish the running surface of the truck road.
 - Following use, the temporary pipe shall be removed and the placed native soil shall be removed and drifted along the approaches.
 - No significant alteration to the bed and bank of the stream shall occur.
- Road approaches to armored fords shall be treated with seed and straw mulch out to the first drainage structure (i.e. waterbar) or hydrologic divide to prevent transport of sediment pursuant to Item 18, Section II.
- Bank and channel armoring may occur when appropriate to provide channel and bank stabilization.
- Armored ford armoring shall be reapplied following use as needed to maintain a permanent crossing.

BMP: Armored Ford [Fill] (Cont.)



FIGURE 120. This armored fill crossing of a steep, ephemeral stream was constructed to provide a low maintenance crossing. The crossing has been deeply dipped to reduce the volume of road fill and to eliminate the potential for stream diversion. The fill slope has been heavily armored through the axis of the crossing to contain flood flows and prevent down-cutting. Armored fills cannot be used on fish bearing streams.

HANDBOOK FOR FOREST, RANCH AND RURAL ROADS

BMP: Armored Ford [Fill] (Cont.)



FIGURE 121D. Well graded rock armor is then backfilled into the structure and spread across the breadth of the U-shaped stream crossing, and about one-third the way up the roadbed, so that streamflow will only flow over or come in contact with resistant armor material. The armor must be spread and compacted across the design width of the expected flood flow channel width so peak flows will not flank the armored structure.



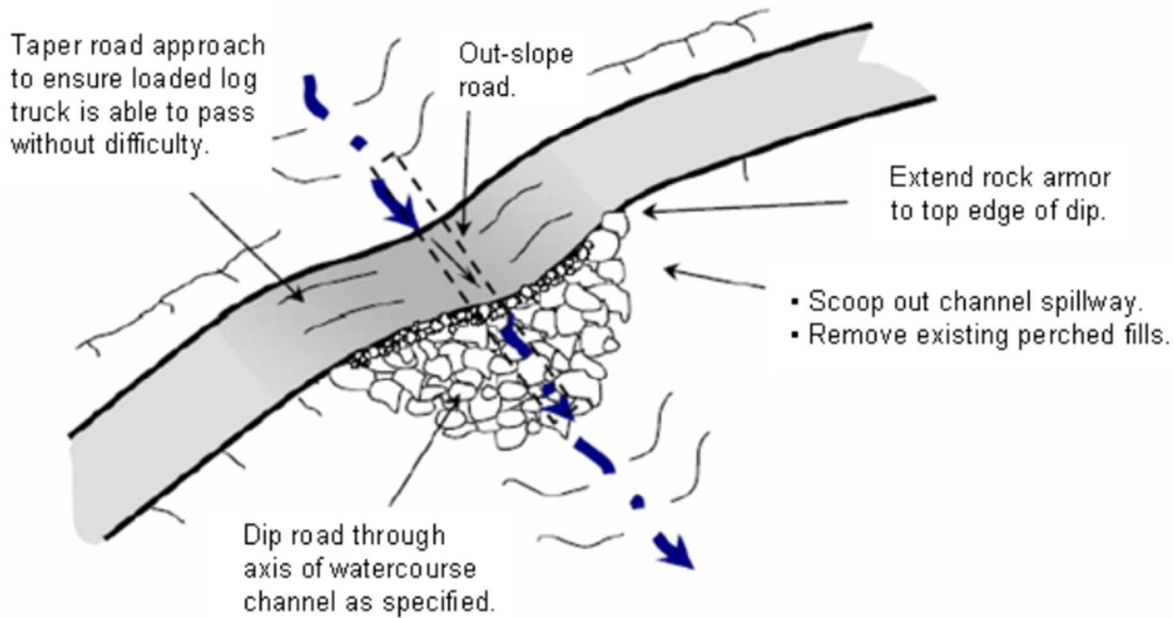
FIGURE 121E. Two weeks after this armored fill was constructed, a storm flow event occurred and the structure maintained its function and integrity. The road approaches had not yet been compacted or surfaced with road rock.



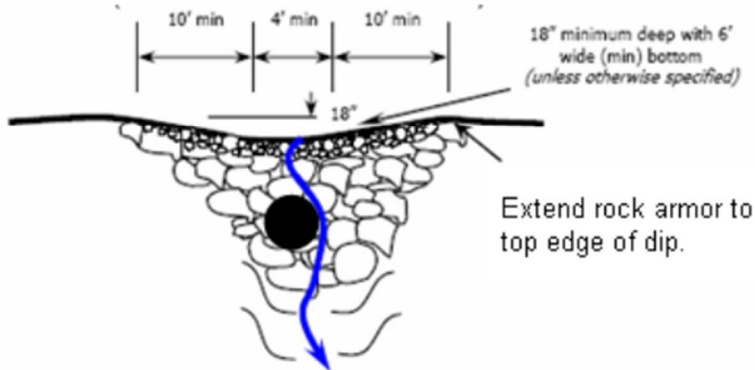
FIGURE 121F. The same armored fill as it appeared after the first winter flood flows. No maintenance was required to reopen the road. It is also clear that no stream diversion is possible at this stream crossing site, and the volume of fill within the crossing has been reduced to the minimum amount needed to maintain a relatively smooth driving surface on this low volume road.

BMP: Vented Ford

Vented Ford

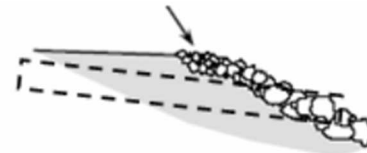


Dip area to accommodate a culvert sized for 100-year flow (minimum dimensions given below).



LIP

- Use smaller rock at lip of ford.
- Fill voids with smaller rock to prevent piping around the larger rock.



BMP: Crossing Abandonment

- When fills are removed they shall be excavated to form a channel that is as close as feasible to natural watercourse grade and orientation, and that is wider than the natural channel.
- Excavated banks shall be laid back to a 2:1 (50%) or natural slope.
- Temporary crossings shall be removed by November 15.
 - Any temporary culvert crossing left in after October 15 or installed between October 15 and May 1, shall be sized to accommodate the estimated 100-year flow.
- Bank and channel armoring may occur when appropriate to provide channel and bank stabilization.

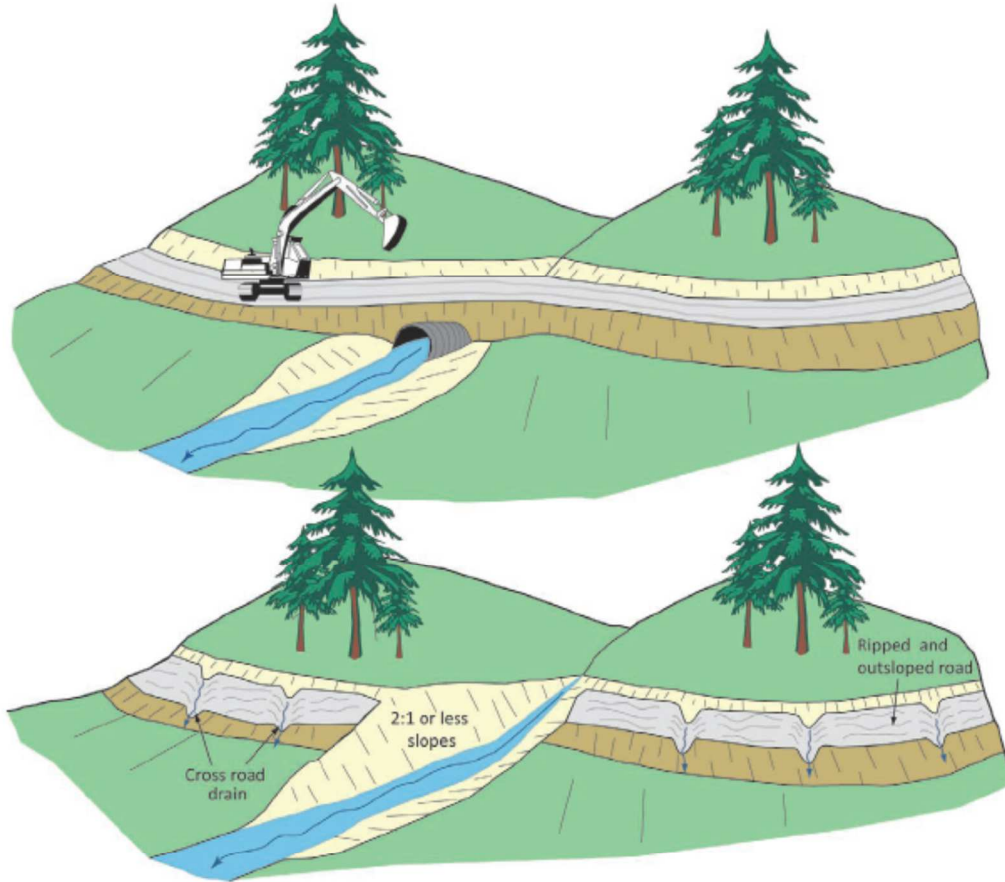


FIGURE 263. On roads that are to be closed (decommissioned), all stream crossing culverts and fills should be removed. Stream crossing excavations are best performed using an excavator. The original channel should be excavated and exhumed down to the former streambed, with a channel width equal or greater than the natural channel above and below the crossing. Sideslopes should be laid back to a stable angle, typically a 2:1 (50%) gradient, or less. Spoil can be endhauled off-site or stored on the road bench adjacent the crossing, provided it is placed and stabilized where it will not erode or fail and enter the stream.

BMP: Permanent Crossing Decommissioning (Cont.)

- Excavating and removing all fill materials placed in the stream channel when the crossing was originally built.
- Fill material should be excavated to recreate the original channel grade (slope) and orientation.
- The excavated channel bed should be as wide, or slightly wider than, the original watercourse channel.
 - This can be better determined by observing the channel width of the watercourse up slope of crossing to be removed at a point in which the crossing or any other disturbance has not affected the natural channel slope and width.
- If the channel sideslopes were disturbed, they should be graded (excavated) back to a stable angle (generally less than 50% (2:1)) to prevent slumping and soil movement.
- The bare soils should then be mulched, seeded, and planted to minimize erosion until vegetation can protect the surface.
- The approaching, hydrologically connected road segments should be cross-road drained to prevent road runoff from discharging across the freshly excavated channel sideslopes.

BMP: Rolling Dip Design and Placement

- Rolling dips are drainage structures designed to force surface water to be drained from the road surface.
- The road shall dip into, and rise out of, the rolling dip to eliminate the potential of road surface runoff to run further down road way.
- The rolling dip shall be constructed with clean native materials or rock surfaced where specified.
- The rolling dips outlet may be armored to resist down-cutting and erosion of the outboard road fill.
- Do not discharge rolling dips into any areas that show signs of instability or active landsliding.
- If the rolling dip is designed to divert both road surface and ditch runoff, block the down-road ditch with compacted fill in order to force all ditch flows through the trough (low point) of the rolling dip.

BMP: Rocked Rolling Dip Design and Placement

- Rocked rolling dips are drainage structures designed to carry known sources of surface water across road ways or from known persistently wet segments of road such as swales without defined watercourses or road segments with heavy bank/road seepage.
- The road shall dip into, and rise out of, the rocked rolling dip to minimize diversion potential.
- The rocked rolling dip shall be constructed with clean rock that is large enough to remain in place during peak flows. Rock size shall vary relative to the anticipated flow through the dip with larger rock used in location where greater flow is anticipated.
- The rocked rolling dips inlet and outlet shall be armored to resist down-cutting and erosion.
- The entire width of the rocked rolling dip shall be rock armored to a minimum of 5-feet from the centerline of the dipped portion of the rolling dip.
- If a keyway is necessary, the rocked rolling dip keyway at the base of the dip shall be of sufficient size, depth and length to support materials used in the rocked rolling dip construction back up to the road crossing interface.
- Do not discharge rolling dips into any areas that show signs of instability or active landsliding.
- If the rolling dip is designed to divert both road surface and ditch runoff, block the down-road ditch with compacted fill.
- The rolling dip should be designed as a broad feature ranging from 10-100 feet long so that it is drivable by most types of vehicular traffic and not significantly inhibit traffic and road use.

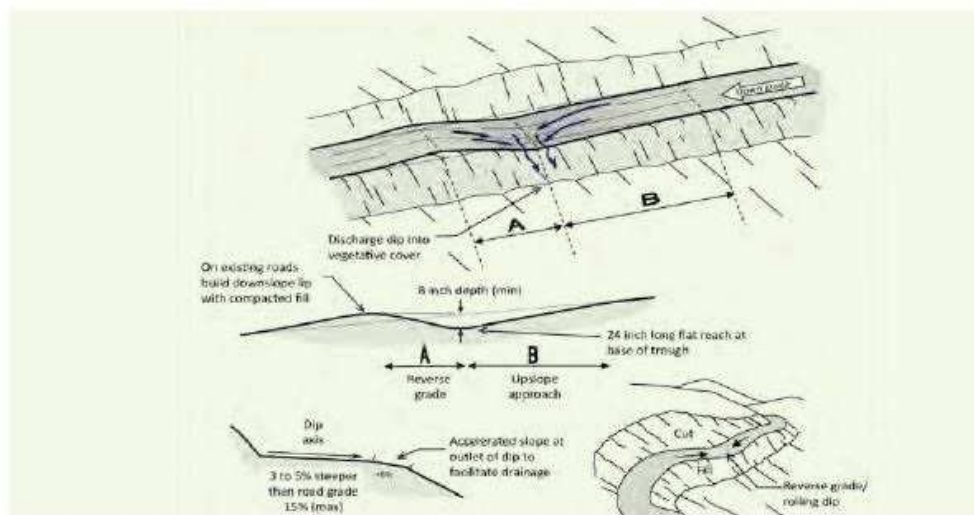
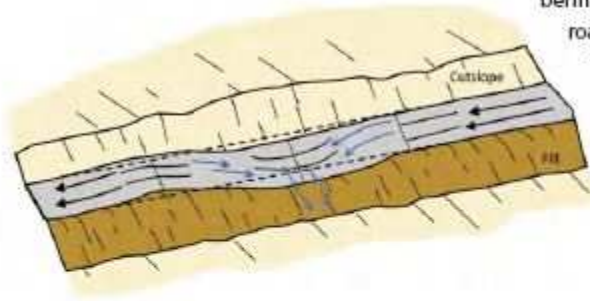


FIGURE 34. A classic Type I rolling dip, where the excavated up-road approach (B) to the rolling dip is several percent steeper than the approaching road and extends for 60 to 80 feet to the dip axis. The lower side of the structure reverses grade (A) over approximately 15 feet or more, and then falls down to rejoin the original road grade. The dip must be deep enough that it is not obliterated by normal grading, but not so deep that it is difficult to negotiate or a hazard to normal traffic. The outward cross-slope of the dip axis should be 3% to 5% greater than the up-road grade (B) so it will drain properly. The dip axis should be out-sloped sufficiently to be self-cleaning, without triggering excessive downcutting or sediment deposition in the dip axis (Modified from: Best, 2013).

HANDBOOK FOR FOREST, RANCH AND RURAL ROADS

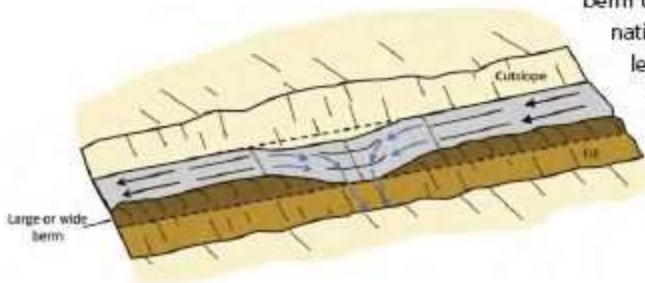
BMP: Rolling Dip Design and Placement (Types)

Type 1 Rolling Dip (Standard)



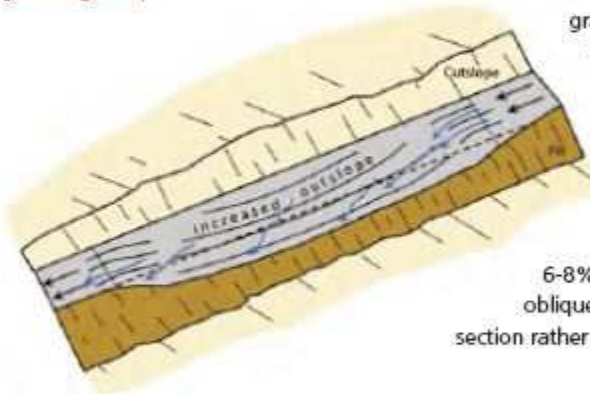
Type 1 rolling dips are used where road grades are less than about 12-14% and road runoff is not confined by a large through cut or berm. The axis of the dip should be perpendicular to the road alignment and sloped at 3-4% across the road tread. Steep roads will have longer and more abrupt dip dimensions to develop reverse grade through the dip axis. The road tread and/or the dip outlet can be rocked to protect against erosion, if needed.

Type 2 Rolling Dip (Through-cut or thick berm road reaches)



Type 2 rolling dips are constructed on roads up to 12-14% grade where there is a through cut up to 3 feet tall, or a wide or tall berm that otherwise blocks road drainage. The berm or native through cut material should be removed for the length of the dip, or at least through the axis of the dip, to the extent needed to provide for uninterrupted drainage onto the adjacent slope. The berm and slope material can be excavated and endhauled, or the material can be sidecast onto native slopes up to 45%, provided it will not enter a stream.

Type 3 Rolling Dip (Steep road grade)



Type 3 rolling dips are utilized where road grades are steeper than about 12% and it is not feasible to develop a reverse grade that will also allow passage of the design vehicle (steep road grades require more abrupt grade reversals that some vehicles may not be able to traverse without bottoming out).

Instead of relying on the dip's grade reversal to turn runoff off the roadbed, the road is built with an exaggerated outslope of 6-8% across the dip axis. Road runoff is deflected obliquely across the dip axis and is shed off the outsloped section rather than continuing down the steep road grade.

FIGURE 36. *Rolling dip types*

BMP: Rolling Dip Design and Placement

FIGURE 33A.

Rolling dip constructed on a rock surfaced rural road. The rolling dip represents a change-in-grade along the road alignment and acts to discharge water that has collected on, or is flowing down, the road surface. This road was recently converted from a high maintenance, insloped, ditched road to a low maintenance, outsloped road with rolling dips.



FIGURE 33B.

This side view of an outsloped road shows that the rolling dip does not have to be deep or abrupt to reverse road grade and effectively drain the road surface. This outsloped forest road has rolling dips that allow all traffic types to travel the route without changing speed.



BMP: Waterbar/Rolling Dip Combined with DRC



FIGURE 39.

Waterbars are often used to drain surface runoff from seasonal, unsurfaced roads. Because they are easily broken down by vehicles, waterbars are only used on unsurfaced roads where there is little or no wet weather traffic. In this photo, a waterbar and ditch relief culvert are used to drain all road surface and ditch runoff from the insloped road prism.

HANDBOOK FOR FOREST, RANCH AND RURAL ROADS

Diagram shows and discussed the use of a waterbar. However, a DRC combined with a rolling dip structure provides the same surface and ditch drainage for roads used year-round. Just as with the waterbar in the photo above, The DRC is installed just upslope from the rolling dip. This also creates a fail-safe should the DRC become plugged or overwhelmed.



FIGURE 238. Traffic and surface runoff from graveled roads often produces surface erosion, turbid runoff and fine sediment transport that can be delivered to streams. Where ditches can't be eliminated, sediment traps and roadside settling basins can be installed to capture and remove most of the eroded sediment. This settling basin has been constructed along the inside ditch just before a stream crossing culvert inlet (see arrow). Eroded sediment from the road and ditch are deposited in the basin before flow is released to the stream. Fine sediments have filled about 1/3 of this basin and vegetation is now growing. Sediment basins require periodic maintenance to maintain their storage capacity.

HANDBOOK FOR FOREST, RANCH AND RURAL ROADS

BMP: Road Outsloping



HANDBOOK FOR FOREST, RANCH, AND RURAL ROADS

FIGURE 29. Road shape changes as the road travels through the landscape. For example, an out-sloped road will have a steep or “banked” outslope through inside curves, a consistent outslope through straight reaches and a flat or slightly insloped shape as it goes through an outside curve. The road may have an outslope of 2-3% across the travel surface while the shoulder is more steeply outsloped to ensure runoff and sediment will leave the roadbed.

BMP: Steep Road Drainage Structures

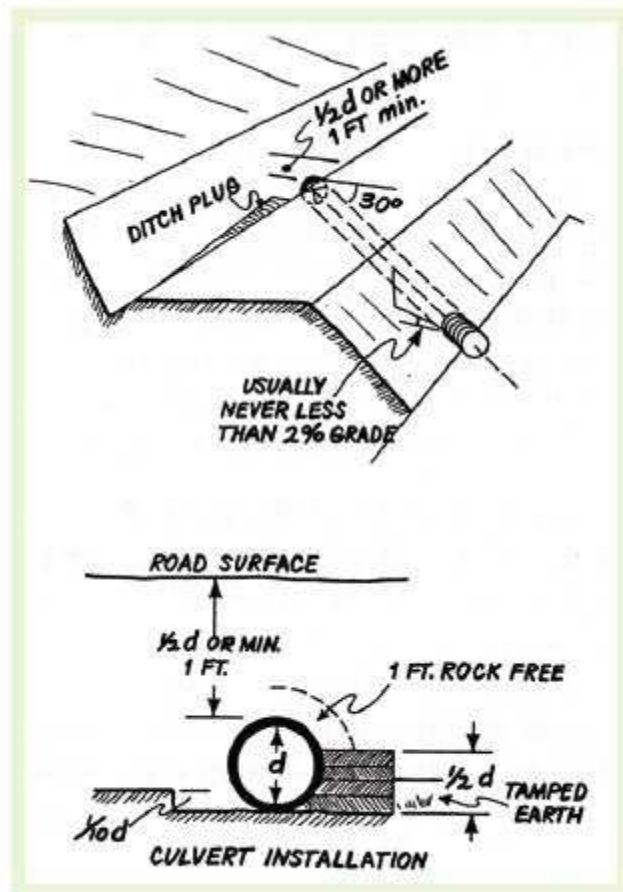


FIGURE 55. Steep roads that go straight up or down a hillside are very difficult to drain. This steep, fall line road developed a through cut cross section that was drained using lead out ditches to direct runoff off the road and onto the adjacent, vegetated hillside. The road was "outsloped" to drain runoff to the right side, and the lead out ditch was built slightly steeper than the road grade, to be self-cleaning. Four lead out ditches have been constructed at 100-foot intervals to the bottom of the hillside.

HANDBOOK FOR FOREST, RANCH AND RURAL ROADS

BMP: Ditch Relief Culvert

- Install ditch relief culverts at an oblique (typically 30 degree) angle to the road so that ditch flow does not have to make a sharp angle turn to enter the pipe. On low gradient roads (<5%), where ditch flow is slow, ditch relief culverts can be installed at right angles to the road.
- Install ditch relief culverts (DRC) to outlet at, and drain to, the base of the fill
- If it cannot be installed at the base of the fill, install the DRC with a grade steeper than the inboard ditch draining to the culvert inlet, and then install a downspout on the outlet to carry the culverted flow to the base of the fillslope or energy dissipater material at outlet to prevent erosion or the outboard road fill.
- Downspouts longer than 20 feet should be secured to the hillslope for stability.
- Ditch relief culverts should not carry excessive flow such that gulying occurs below the culvert outlet or such that erosion and down-cutting of the inboard ditch is occurring.
- Do not discharge flows from ditch relief culverts onto unstable areas or highly erodible hillslopes.
- If the ditch is on an insloped or crowned road, consider reshaping road outsloping to drain the road surface. The ditch and the ditch relief culvert would then convey only spring flow from the cutbank and hillslope runoff, and not turbid runoff from the road surface.



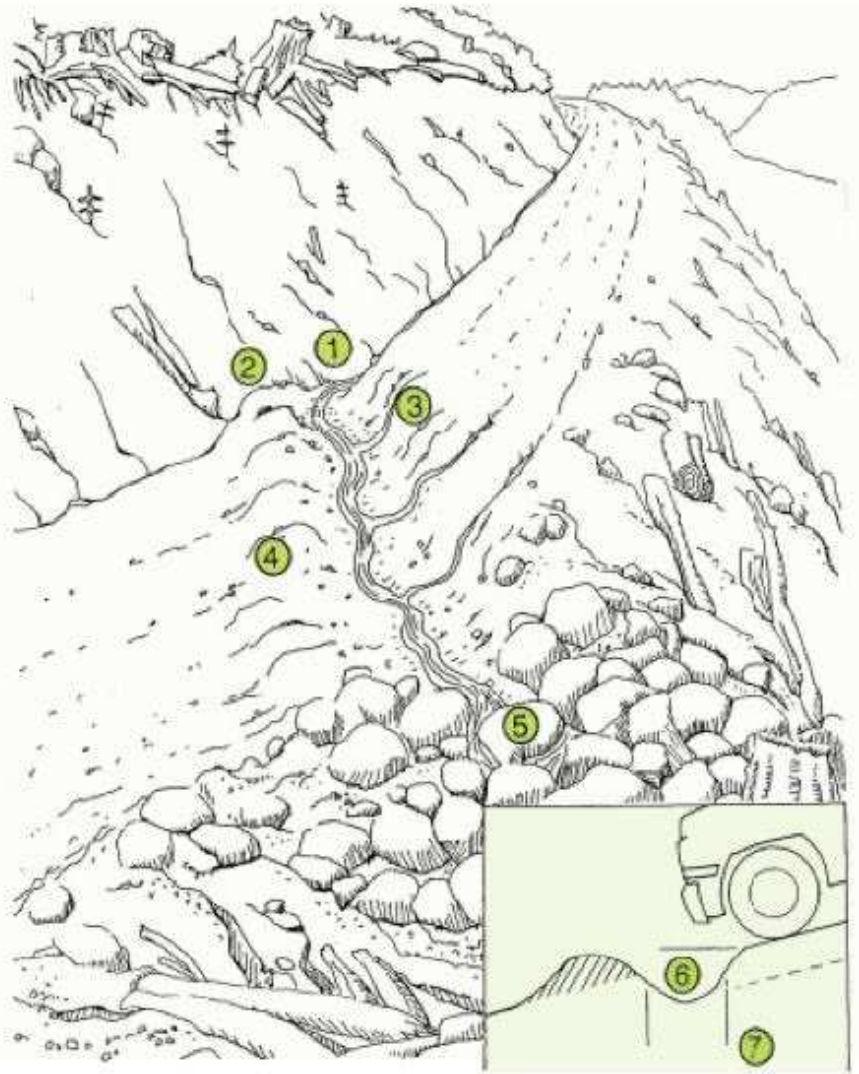
HANDBOOK FOR FOREST, RANCH AND RURAL ROADS

FIGURE 48. *The elements of a properly installed ditch relief culvert. The culvert is angled at about 30 degrees to the road alignment to help capture flow and prevent culvert plugging or erosion of the inlet area. It is set at the base of the fill (ideally) or with a grade slightly steeper than the grade of the contributing ditch (but never with a grade less than 2 percent) (USDA-SCS, 1983). At a minimum, the grade of the ditch relief culvert should be sufficient to prevent sediment accumulation at the inlet or deposition within the culvert itself (it should be self-cleaning) (USDA-SCS, 1983).*

BMP: Waterbar Construction

FIGURE 40. Waterbars are constructed on unsurfaced forest and ranch roads that will have little or no traffic during the wet season. The waterbar should be extended to the cutbank to intercept all ditch flow (1) and extend beyond the shoulder of the road. A berm (2) must block and prevent ditch flow from continuing down the road during flood flows. The excavated waterbar (3) should be constructed to be self-cleaning, typically with a 30° skew to the road alignment with the excavated material bermed on the downhill grade of the road (4). Water should always be discharged onto the downhill side on a stable slope protected by vegetation. Rock (shown in the figure) should not be necessary if waterbars are spaced close enough to prevent serious erosion. (5) The cross ditch depth (6) and width (7) must allow vehicle cross-over without destroying the function of the drain. Several alternate types of waterbars are possible, including one that drains only the road surface (not the ditch), and one that drains the road surface into the inside ditch (BCMF, 1991).

HANDBOOK FOR FOREST, RANCH, AND RURAL ROADS

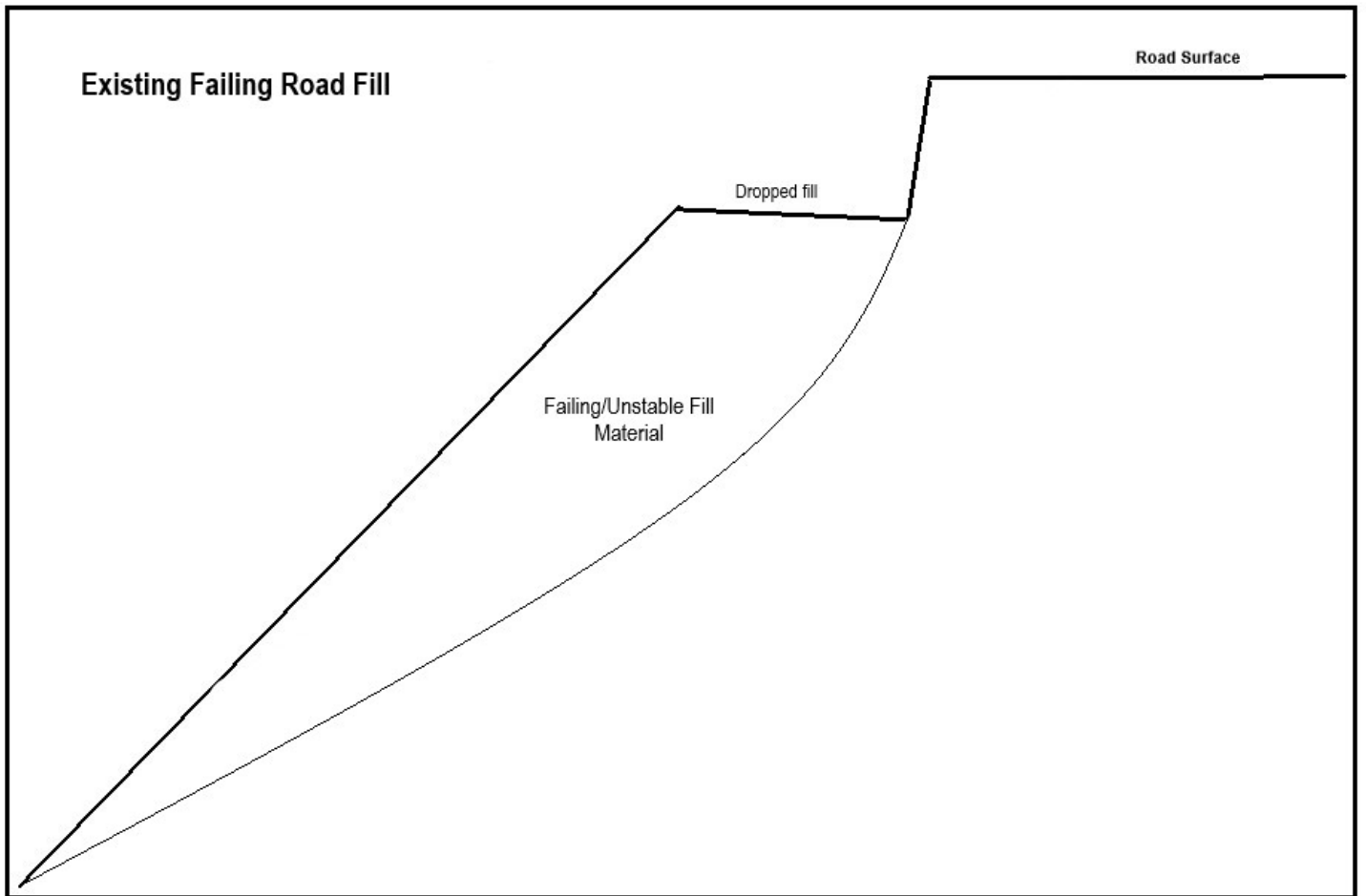


BMP: Unstable Fill Removal and Treatment

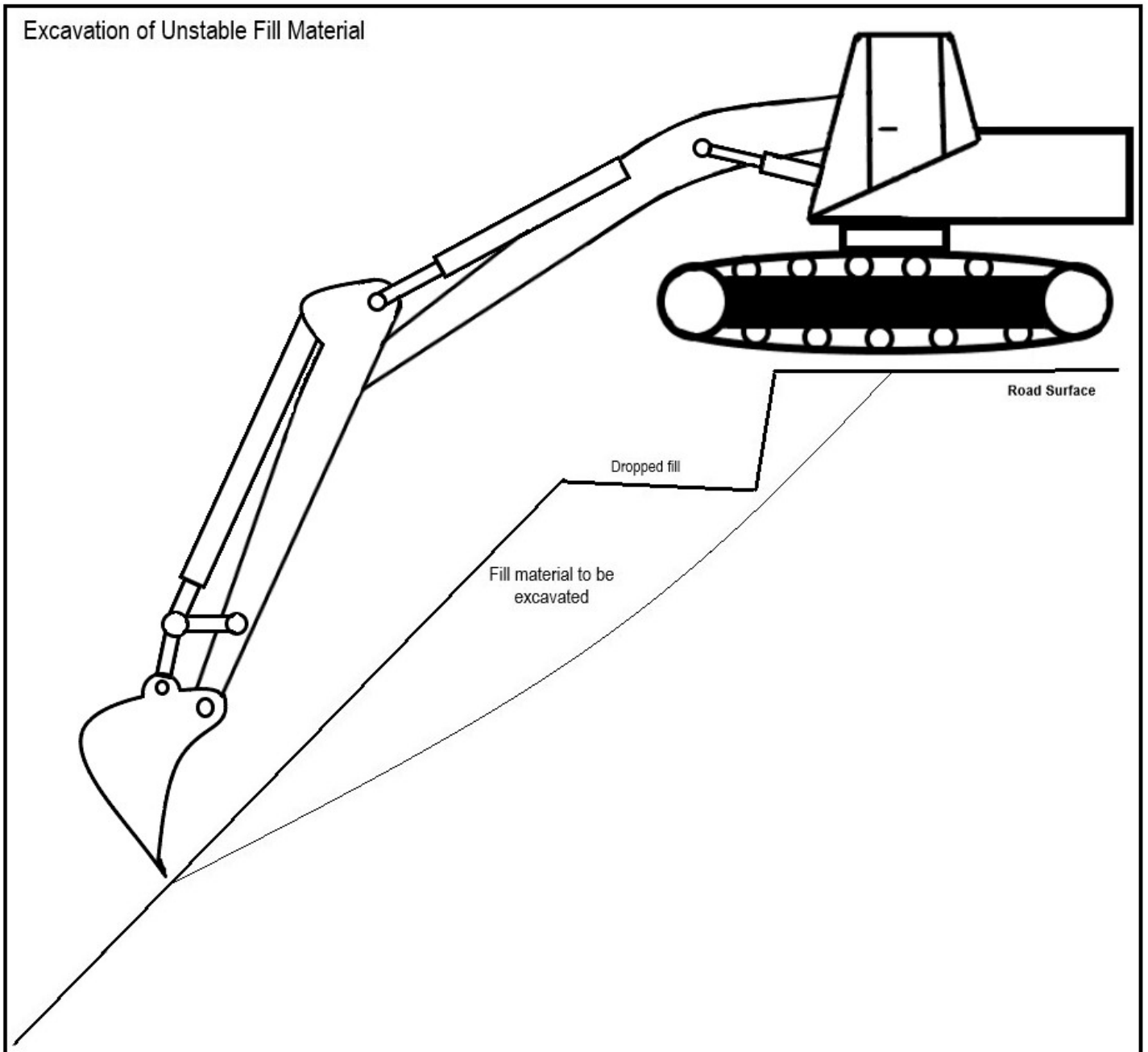


FIGURE 230. *The most cost-effective treatment for unstable fills along the outside of a forest, ranch or rural road is simply the direct excavation of the unstable material. If road width is too narrow, additional width can often be derived from cutting into the bank. The excavation should encompass the unstable fill materials, beginning at the inside crack or scarp, and extending out and down the fill slope as far as possible. For proper surface drainage, and to retrieve most of the unstable fill, the excavation should have a concave profile when completed. Typically, the bulk of the fill is within 20 to 25 feet of the outside edge of the road and is easily reached by a midsized excavator. Any remaining fill is likely to be small enough that it will not fail or travel far enough to reach the stream.*

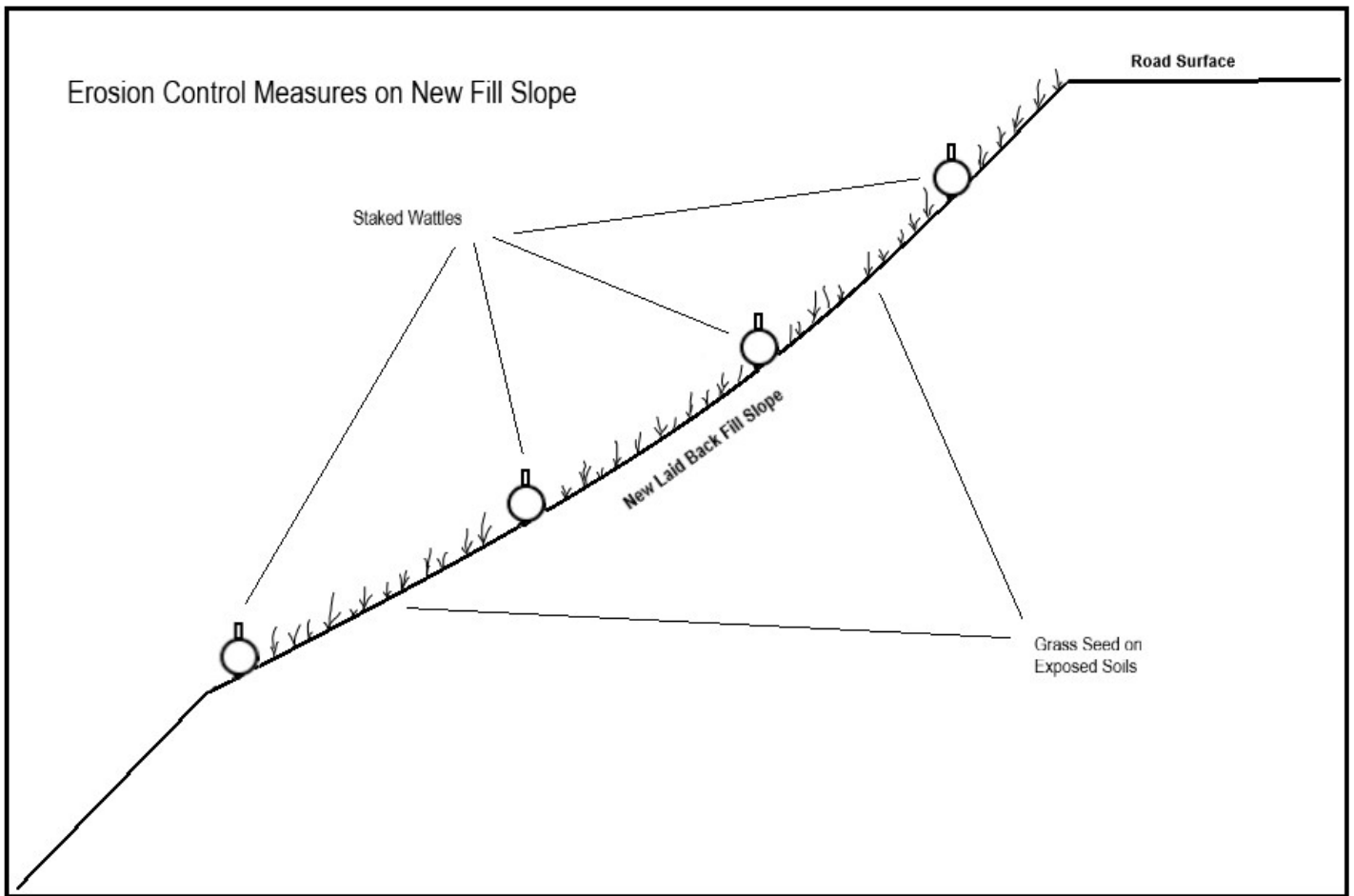
BMP: Unstable Fill Removal and Treatment



BMP: Unstable Fill Removal and Treatment



BMP: Unstable Fill Removal and Treatment



BMP: Rock Armor Cutbank



FIGURE 52. This wet and potentially unstable cut slope on a newly constructed road was stabilized using a buttress of large rock armor. To assure their effectiveness, rock buttresses and other retaining structures should be designed by a qualified engineer or engineering geologist.

HANDBOOK FOR FOREST, RANCH AND RURAL ROADS

BMP: Rip-Rap Size Class Table

TABLE 25. Standard classification and gradation of riprap by size of rock¹

Riprap size class	Median particle weight ²	Median particle diameter ² (in)	Minimum and maximum allowable particle size (in) ²						
			D ₁₅		D ₅₀		D ₈₅		D ₁₀₀
			Min	Max	Min	Max	Min	Max	Max
Class I	20 lb	6	3.7	5.2	5.7	6.9	7.8	9.2	12.0
Class II	60 lb	9	5.5	7.8	8.5	10.5	11.5	14.0	18.0
Class III	150 lb	12	7.3	10.5	11.5	14.0	15.5	18.5	24.0
Class IV	300 lb	15	9.2	13.0	14.5	17.5	19.5	23.0	30.0
Class V	¼ ton	18	11.0	15.5	17.0	20.5	23.5	27.5	36.0
Class VI	3/8 ton	21	13.0	18.5	20.0	24.0	27.5	32.5	42.0
Class VII	½ ton	24	14.5	21.0	23.0	27.5	31.0	37.0	48.0
Class VIII	1 ton	30	18.5	26.0	28.5	34.5	39.0	46.0	60.0
Class IX	2 ton	36	22.0	31.5	34.0	41.5	47.0	55.5	72.0
Class X	3 ton	42	25.5	36.5	40.0	48.5	54.5	64.5	84.0

¹Lagasse et al. (2006)

²Equivalent to spherical diameter

BMP: Storage Bladders

- Storage bladders shall be located and designed to minimize the potential for impacts due to rolling and/or failure. Storage bladders should be stored on flat slopes where stability will not be affected.
- Storage bladders shall be located to minimize the potential for water to flow into a watercourse in the event of a catastrophic failure.
- Bladders shall not be used unless the bladder is safely contained within a secondary containment system with sufficient capacity to capture 110 percent of a bladders maximum volume in the vent of bladder failure.
- Secondary containment is recommended in the form of a dirt berm, containment pit, combination of both, or impermeable material with skeletal support. The containment should be capable of holding 110 percent of the bladders volume.
- Secondary containment systems shall be of sufficient strength and stability to withstand the forces of released contents in the event of catastrophic bladder failure.
- Secondary containment systems that are exposed to precipitation shall be designed and maintained with sufficient capacity to accommodate precipitation and storm water inputs from a 25-year, 24-hour storm event.
- Bladders and containment systems shall be periodically inspected to ensure integrity.



This is an example of a containment pit which will assist in mitigating the impacts if this storage bladder failed.

BMP: Cultivation Site Restoration

- Remove all cultivation and associated materials from designated cultivation site.
 - This includes plant mass, root balls, potting containers, cultivation medium and any materials associated with the preparation, cultivation, and harvest of commercial cannabis.
 - Cultivation medium removed from the site shall be stored/disposed of in compliance with Order conditions related to spoils management.
- All disturbed and/or unstable slopes shall be stabilized and returned to pre-project conditions.
 - Slopes shall be contoured as close as feasible to natural grade and aspect.
 - Temporary erosion control shall be applied to prevent sediment run-off.
- Soil exposed as a result of project work, soil above rock riprap, and interstitial spaces between rocks shall be revegetated with native species by live planting, seed casting, or hydroseeding prior to the rainy season of the year work is completed.
 - Native plants characteristic of the local habitat shall be used for revegetation when implementing and maintaining cleanup/restoration work in riparian and other sensitive areas.
 - Native forbes and graminoids shall be planted to replace sediment stabilization, sediment filtration and nutrient filtration
 - Native trees and shrubs shall be planted to replace bank stabilization, inputs of large woody debris and temperature control within riparian areas.
 - Restoration of the quality/health of the riparian stand shall promote: 1) shade and microclimate controls; 2) delivery of wood to channels, 3) slope stability and erosion control, 4) ground cover, and 5) removal of excess nutrients.