

5/9/2017 9:07:19 AM

SUSPENDED GYP BOARD CEILING GENERAL NOTES

- 1. CONSTRUCTION, WORKMANSHIP AND MATERIAL SHALL CONFORM TO THE 2013 CALIFORNIA BUILDING STANDARD CODE (CBC 2013).
2. THE CONTRACTOR SHALL NOTIFY OSHPD AND THE REGISTERED DESIGN PROFESSIONAL (RDP) IN RESPONSIBLE CHARGE WHERE A CONFLICT OR DISCREPANCY OCCURS BETWEEN THE CONSTRUCTION DRAWINGS AND ANY OTHER PORTION OF THE CONSTRUCTION DOCUMENTS, FIELD CONDITIONS, OR WHERE ANY CONDITIONS ARISE NOT COVERED BY THESE DOCUMENTS WHEREIN WORK WILL NOT COMPLY WITH CODE REQUIREMENTS.
3. THE INTENT OF THE DRAWINGS AND SPECIFICATIONS IS TO CONSTRUCT THE HOSPITAL BUILDING IN ACCORDANCE WITH THE CALIFORNIA BUILDING STANDARD CODE, 2013 (CBC 2013). SHOULD ANY CONDITION DEVELOP NOT COVERED BY THE APPROVED CONSTRUCTION DOCUMENTS WHEREIN THE WORK WILL NOT COMPLY WITH CBC 2013, A CHANGE ORDER DETAILING AND SPECIFYING THE REQUIRED WORK SHALL BE SUBMITTED TO AND APPROVED BY OSHPD BEFORE PROCEEDINGS WITH THE WORK.
4. GALVANIZED METAL STUDS, TRACKS AND SHEET STEEL SHALL CONFORM TO ASTM A653-11 MATERIAL OR OTHER EQUIVALENT ASTM LISTED MATERIALS IN SECTION A2.1 OF THE AISI 300-07/02-10; NORTH AMERICAN SPECIFICATION FOR THE DESIGN OF COLD-FORMED STEEL STRUCTURAL MEMBERS WITH SUPPLEMENT 2, DATED 2010, WITH A MINIMUM YIELD STRENGTH OF 33 KSI FOR 43 MIL (18 GAGE) AND LIGHTER AND MINIMUM YIELD STRENGTH OF 50 KSI FOR HEAVIER GAGES.

METAL STUDS AND TRACKS SHALL BE OF SIZE, THICKNESS AND SECTION PROPERTIES SHOWN ON TABLES 1.1, 1-2 AND 1-3 OF THE AISI MANUAL, COLD-FORMED STEEL, DESIGN, 2008 EDITION. THE RDP IN RESPONSIBLE CHARGE SHALL OBTAIN OSHPD APPROVAL FOR ANY SUBSTITUTIONS.

5. ELECTRICAL METALLIC TUBE (EMT) SHALL BE ANSI C80.3/UL 797 CARBON STEEL WITH G90 GALVANIZING. EMT SHALL HAVE MINIMUM YIELD STRENGTH OF (Fy =) 30 KSI AND MINIMUM ULTIMATE STRENGTH OF (Fu =) 48 KSI.

6. THESE OPD REFER TO FASTENER TYPE AND SIZE BUT DO NOT SPECIFY OR ENDORSE A SPECIFIC MANUFACTURER. THE RDP IN RESPONSIBLE CHARGE SHALL SELECT A MANUFACTURER AND SELECTED FASTENER CAPACITIES SHALL MATCH OR EXCEED THE STRENGTHS LISTED HEREIN. THE FOLLOWING REQUIREMENTS SHALL ALSO BE MET:
a. SHEET METAL SCREWS SHALL COMPLY WITH ASTM C 1513-10, ASME B18.6.4-98 (R2005) AND ICC-ES AC 118 AND ALLOWABLE STRENGTH SHALL BE BASED ON INFORMATION PROVIDED IN CG1.31 AND CG1.32. PENETRATION OF SCREWS THROUGH JOINED MATERIAL SHALL NOT BE LESS THAN THREE EXPOSED THREADS.
b. WELDING SHALL BE IN ACCORDANCE WITH AWS D1.3 USING E60XX SERIES ELECTRODES. FIELD WELDING SHALL HAVE SPECIAL INSPECTION IN ACCORDANCE WITH 2013 CBC SECTION 1705A.2.

c. POST-INSTALLED ANCHORS (E.G. EXPANSION ANCHORS, SCREW ANCHORS AND POWER ACTUATED FASTENERS) SHALL HAVE SPECIAL INSPECTION AND TESTING IN ACCORDANCE WITH THE 2013 CBC SECTIONS 1705A.3 & 1913A.7. FOR QUALIFICATION, DESIGN AND USE OF POST-INSTALLED ANCHORS IN CONCRETE SEE THE 2013 CBC SECTIONS 1616A.1.19 AND 1908A.1.1. LISTING OF CURRENT ICC-ES EVALUATION REPORTS (OR REPORTS FROM OTHER TESTING AGENCIES ACCEPTABLE TO OSHPD) SHALL BE REQUIRED FOR FASTENER USED.
d. POWER-ACTUATED FASTENERS (PAF), POWDER DRIVEN FASTENERS (PDF), POWER DRIVEN PINS (PDP) AND SHOT PINS ALL REPRESENT THE SAME FASTENER AND WILL HEREAFTER BE REFERRED TO AS POWER ACTUATED FASTENERS (PAF). PAF SHALL SATISFY THE CURRENT AC308 ACCEPTANCE CRITERIA FOR FASTENERS POWER-DRIVEN INTO CONCRETE, STEEL AND MASONRY ELEMENTS AND THE 2013 CBC SECTIONS 1908A.1.1. LISTING OF CURRENT ICC-ES EVALUATION REPORTS (OR REPORTS FROM OTHER TESTING AGENCIES ACCEPTABLE TO OSHPD) SHALL BE REQUIRED FOR FASTENERS USED.

e. FOR PAF INSTALLED IN STEEL THE FASTENER PENETRATION SHALL HAVE THE ENTIRE POINTED END OF THE FASTENER DRIVEN THROUGH THE STEEL MEMBER, EXCEPT AS NOTED IN CURRENT REPORTS FROM TESTING AGENCIES ACCEPTABLE TO OSHPD.

Section Title : OSHPD STANDARD GYPSUM BOARD CEILING DETAILS OPD No.
Sheet Title : GYP-BOARD SUSPENDED CEILING PAGE 1 OF 5 CG0.00

05/11/2017 OPD-0003-13: Reviewed for Code Compliance by Karim Page 25 of 75

5/9/2017 9:07:20 AM

12. EXPANSION JOINTS, SEISMIC SEPARATIONS, AND PENETRATIONS

- a. EXPANSION JOINTS SHALL BE PROVIDED IN THE CEILING AT INTERSECTIONS OF CORRIDORS AND AT JUNCTIONS OF CORRIDORS WITH LOBBIES OR OTHER SIMILAR AREAS.
b. FOR CEILING AREAS EXCEEDING 2500 SQUARE FEET, A SEISMIC SEPARATION JOINT SHALL BE PROVIDED TO DIVIDE THE CEILING INTO AREAS NOT EXCEEDING 2500 SQ. FT.
c. PENETRATIONS THROUGH THE CEILING FOR SPRINKLER HEADS AND OTHER SIMILAR DEVICES THAT ARE NOT INTEGRALLY TIED TO THE CEILING SYSTEM IN THE LATERAL DIRECTION SHALL HAVE A TWO (2) INCH OVERSIZED RING, SLEEVE OR ADAPTER THROUGH THE CEILING TILE TO ALLOW FREE MOVEMENT OF ONE (1) INCH IN ALL HORIZONTAL DIRECTIONS. A FLEXIBLE SPRINKLER HOSE FITTING THAT CAN ACCOMMODATE ONE (1) INCH OF CEILING MOVEMENT SHALL BE PERMITTED TO BE USED IN LIEU OF THE OVERSIZED RING, SLEEVE OR ADAPTER. SUCH FLEXIBLE SPRINKLER HOSE SHALL BE ADEQUATELY SUPPORTED FROM SOFFIT SO AS NOT TO EXCEED THE MAXIMUM TRIBUTARY WEIGHT OF THE CEILING.

13. LATERAL FORCE BRACING
LATERAL FORCE BRACING IS REQUIRED IN ACCORDANCE WITH THIS SECTION FOR ALL CEILING AREAS, UNLESS EXCEPTED. LATERAL FORCE BRACING MAY BE OMITTED FOR SUSPENDED ACOUSTICAL CEILING SYSTEMS WITH A CEILING AREA OF 144 SQ. FT. OR LESS, WHEN PERIMETER SUPPORT ARE PROVIDED AND PERIMETER WALLS ARE DESIGNED TO CARRY THE CEILING LATERAL FORCES.

- a. PROVIDE LATERAL FORCE BRACING ASSEMBLIES CONSISTING OF A STRUT AND FOUR (4) #12 GAGE BRACING WIRES ORIENTED 90 DEGREES FROM EACH OTHER.
b. LATERAL FORCE BRACING ASSEMBLIES SHALL BE SPACED IN ACCORDANCE WITH CG2.20 THROUGH CG2.22 AND CG2.30 FROM EACH WALL AND AT THE EDGES OF ANY CHANGE OF ELEVATION OF THE CEILING.
c. THE SLOPE OF BRACING WIRES MAY BE FROM 10 TO 45 DEGREES BUT MAY NOT EXCEED 45 DEGREES FROM THE PLANE OF THE CEILING AND WIRES SHALL BE TAUT.
d. STRUTS SHALL BE ADEQUATE TO RESIST THE VERTICAL COMPONENT INDUCED BY THE BRACING WIRES, AND SHALL NOT BE MORE THAN 1 (HORIZONTAL) IN 6 (VERTICAL) OUT OF PLUMB.

14. ATTACHMENT OF HANGER AND BRACING WIRES:

- a. FASTEN #12 HANGER WIRES WITH NOT LESS THAN THREE (3) TIGHT TURNS IN 3 INCHES. HANGER WIRE LOOPS SHALL BE TIGHTLY WRAPPED AND SHARPLY BENT TO PREVENT ANY VERTICAL MOVEMENT OR ROTATION OF THE MEMBER WITHIN THE LOOPS.
b. FASTEN #12 BRACING WIRES WITH FOUR (4) TIGHT TURNS. MAKE ALL TIGHT TURNS WITHIN A DISTANCE OF 1 1/2" INCHES.
c. HANGER OR BRACING WIRE ANCHORED TO THE STRUCTURE SHOULD BE INSTALLED IN SUCH A MANNER THAT THE DIRECTION OF THE ANCHOR ALIGNS AS CLOSELY AS POSSIBLE WITH THE DIRECTION OF THE WIRE.
d. SEPARATE ALL CEILING HANGER AND BRACING WIRES AT LEAST SIX (6) INCHES FROM ALL UNBRACED DUCTS, PIPES CONDUITS, ETC.
e. HANGER WIRES SHALL NOT BE ATTACHED TO OR BEND AROUND INTERFERING MATERIAL OR EQUIPMENT. PROVIDE TRAPEZOID OR OTHER SUPPORT MEMBERS AT OBSTRUCTIONS TO TYPICAL HANGER SPACING. PROVIDE ADDITIONAL HANGERS, STRUTS OR BRACES AS REQUIRED AT ALL CEILING BREAKS, SOFFITS, OR DISCONTINUOUS AREAS.
f. HANGER WIRES THAT ARE MORE THAN 1 (HORIZONTAL) IN 6 (VERTICAL) OUT OF PLUMB SHALL REQUIRE PROJECT SPECIFIC DESIGN.
g. WHEN DRILLED-IN CONCRETE ANCHORS OR PAF ARE USED IN REINFORCED CONCRETE FOR HANGER WIRES, 1 OUT OF 10 WIREANCHOR ASSEMBLIES SHALL BE FIELD TESTED FOR 200 LBS. IN TENSION. WHEN DRILLED-IN CONCRETE ANCHORS ARE USED FOR BRACING WIRES, 1 OUT OF 2 WIRE ANCHOR ASSEMBLIES SHALL BE FIELD TESTED FOR 440 LBS. IN TENSION IN THE DIRECTION OF THE WIRE. PAF IN CONCRETE ARE NOT PERMITTED FOR BRACING WIRES.

Section Title : OSHPD STANDARD GYPSUM BOARD CEILING DETAILS OPD No.
Sheet Title : GYP-BOARD SUSPENDED CEILING PAGE 3 OF 5 CG0.02

05/11/2017 OPD-0003-13: Reviewed for Code Compliance by Karim Page 27 of 75

5/9/2017 9:07:20 AM

17. GYPSUM BOARD INSTALLATION SHALL COMPLY WITH ASTM C840-11:

- a. GYPSUM BOARD SHALL CONSIST OF SINGLE-PLY 1/2" OR 5/8" THICK IN ACCORDANCE WITH ASTM C111-10a.
b. GYPSUM BOARD SHALL BE INSTALLED PERPENDICULAR TO FURRING WITH SCREWS AT 12" ON CENTER MAXIMUM, IN ACCORDANCE WITH ASTM C840-11.
c. GYPSUM BOARD SHALL BE ATTACHED TO FURRING FRAMING WITH ASTM C1002-07 TYPE S (ASTM A568-11b GRADES 1015 TO 1022) SCREWS (NOT LESS THAN, NO. 6, WITH MAJOR DIAMETER NOT LESS THAN 0.136 IN).

Section Title : OSHPD STANDARD GYPSUM BOARD CEILING DETAILS OPD No.
Sheet Title : GYP-BOARD SUSPENDED CEILING PAGE 5 OF 5 CG0.04

05/11/2017 OPD-0003-13: Reviewed for Code Compliance by Karim Page 29 of 75

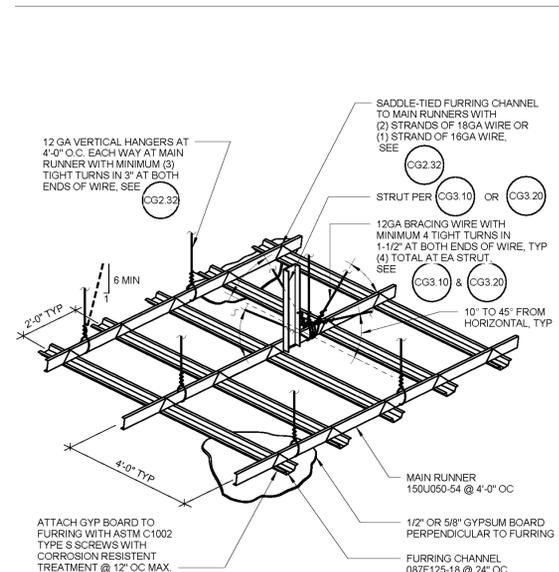

- NOTES:
1. SEE GENERAL NOTES #13 & #14 ON CG0.02
2. STRUTS SHALL NOT REPLACE HANGER WIRES
3. FOR CONDITIONS AT CORRIDOR SEE DRAWING NO. CG2.30
4. FOR MAIN RUNNER AND FURRING CHANNEL SPLICE CONNECTIONS, SEE CG2.31

Section Title : OSHPD STANDARD GYPSUM BOARD CEILING DETAILS OPD No.
Sheet Title : SUSPENDED CEILING BRACING ASSEMBLY CG2.10

05/11/2017 OPD-0003-13: Reviewed for Code Compliance by Karim Page 30 of 75

5/9/2017 9:07:19 AM

7. DESIGN CRITERIA

- a. BUILDING CODE, 2013 CALIFORNIA BUILDING CODE (2013 CBC), ASCE 7-10, AISI 300-07/02-10, AND ASTM C754-11, FOR LOAD COMBINATIONS, ALLOWABLE STRESS DESIGN SHALL BE IN ACCORDANCE WITH 2013 CBC SECTION 1605A.3.1.
b. FASTENER CAPACITIES TABLES WERE DEVELOPED BASED ON ICC REPORTS BY SEVERAL MANUFACTURERS.
c. THE DESIGN ASSUMES THAT BUILDING ELEMENTS AND SUPPORTS, TO WHICH THE COMPONENTS ADDRESSED IN THIS DOCUMENT ARE ANCHORED, HAVE SUFFICIENT CAPACITY TO CARRY THE LOADS IMPOSED BY THE COMPONENTS IN COMBINATION WITH ALL OTHER LOADS. EVALUATION OF THE CAPACITY OF THESE SUPPORTING BUILDING ELEMENTS IS BEYOND THE SCOPE OF THE OPD.
d. THIS OPD IS LIMITED TO CEILING ASSEMBLIES HAVING MAXIMUM DEAD WEIGHT OF 4 PSF, INCLUDING LIGHTING FIXTURES (LUMINAIRES) AND MECHANICAL SERVICES, EACH WEIGHING LESS THAN 56 LBS AND ATTACHED TO CEILING FRAMING SYSTEM. HEAVIER SYSTEM AND THOSE SUPPORTING LATERAL FORCES FROM PARTITION WALLS ARE OUTSIDE THE SCOPE OF THIS OPD AND WILL REQUIRE PROJECT SPECIFIC DESIGN.

8. THE RDP IN RESPONSIBLE CHARGE SHALL VERIFY THE FIRE RESISTANCE AND ACOUSTICAL RATINGS FOR ALL CEILING ASSEMBLIES.

- 9. "CEILING WIRE" SHALL CONFORM WITH GALVANIZED SOFT ANNEALED MILD STEEL WIRE AS DEFINED IN ASTM A641 (CLASS 1 COATING) WITH 70 KSI MINIMUM TENSILE STRENGTH.
a. FOUR (4) TWISTS OF WIRE WITHIN 1 5/8" DEVELOPS THE ALLOWABLE LOAD FOR THE WIRE.
b. THREE (3) TWISTS WITHIN 3" MAY BE USED TO DEVELOP THE MAXIMUM 50% OF ALLOWABLE LOAD.

10. SUSPENSION SYSTEM COMPONENTS SHALL COMPLY WITH ASTM C754
a. MAIN RUNNERS SHALL CONSIST OF 18 GAGE 1-1/2" COLD ROLLED U-CHEANNEL 150U050-54 SPACED AT 4'-0" OC MAX. MAIN RUNNERS SHALL BE SUPPORTED BY HANGER WIRES AT 4'-0" OC MAX AND WITHIN 6" FROM EA END.

b. FURRING CHANNEL SHALL CONSIST OF 25 GAGE 7/8" (HAT) FURRING CHANNELS (087F125-18) AT 2'-0" OC MAX. FURRING CHANNELS SHALL BE SADDLE TIED TO MAIN RUNNERS WITH 16 GAGE TIE WIRE OR A DOUBLE STRAND OF 18 GAGE TIE WIRE.
c. MAIN RUNNERS SHALL BE SPLICED BY LAPPING IN ACCORDANCE WITH CG2.31.
d. FURRING CHANNELS SHALL BE SPLICED BY LAPPING IN ACCORDANCE WITH CG2.31.

e. MAIN RUNNERS AND FURRING CHANNELS ALONG WITH THEIR SPLICES, INTERSECTION CONNECTORS, AND EXPANSION DEVICES SHALL BE DESIGNED AND CONSTRUCTED TO CARRY A MEAN ULTIMATE TEST LOAD OF NOT LESS THAN 270 LBS. IN COMPRESSION & TENSION.
f. HANGER AND BRACING WIRES SHALL BE #12 GAGE (0.106" DIAMETER), SOFT ANNEALED, AND GALVANIZED STEEL WIRES WITH CLASS 1 COATING. THEY MAY BE USED FOR UP TO AND INCLUDING 4'-0" x 4'-0" GRID SPACINGS ALONG AND ATTACHED TO MAIN RUNNERS. SPLICES ARE NOT PERMITTED IN ANY HANGER WIRE.

g. WIRE HANGERS SHALL BE SADDLE-TIED AROUND MAIN RUNNERS SO AS TO PREVENT TURNING OR TWISTING OF THE MEMBER.

11. SUSPENSION SYSTEM INSTALLATION SHALL COMPLY WITH ASTM C754

- a. CEILING GRID MEMBERS SHALL BE ATTACHED TO TWO (2) ADJACENT WALLS. MAIN RUNNERS AND FURRING CHANNEL SHALL BE AT LEAST 1 INCH CLEAR OF OTHER WALL. IF WALLS RUN DIAGONAL TO THE CEILING GRID SYSTEM RUNNERS, ONE END OF MAIN RUNNER AND FURRING SHOULD BE FREE WITH STANDARD CLEARANCES.
b. THE WIDTH OF THE PERIMETER SUPPORTING CLOSURE ANGLE SHALL BE NOT LESS THAN TWO (2) INCHES. USE OF ANGLES WITH SMALLER WIDTHS IN CONJUNCTION WITH PERIMETER CLIPS SHALL REQUIRE AN ALTERNATE METHOD OF COMPLIANCE WITH ADEQUATE JUSTIFICATION AND BE OUTSIDE THE SCOPE OF THIS OPD.

Section Title : OSHPD STANDARD GYPSUM BOARD CEILING DETAILS OPD No.
Sheet Title : GYP-BOARD SUSPENDED CEILING PAGE 2 OF 5 CG0.01

05/11/2017 OPD-0003-13: Reviewed for Code Compliance by Karim Page 26 of 75

5/9/2017 9:07:20 AM

15. CEILING FIXTURES, TERMINALS, AND DEVICES

- a. ALL LIGHT FIXTURES, AIR TERMINALS, GRILLS, OR OTHER DEVICES (REFERRED TO ALL BY COMMON TERM FIXTURES HEREAFTER) SHALL BE MOUNTED IN A MANNER THAT WILL NOT COMPROMISE CEILING PERFORMANCE.
b. ALL FIXTURES SHALL BE SUPPORTED DIRECTLY BY MAIN RUNNERS OR BY SUPPLEMENTAL FRAMING WHICH IS SUPPORTED BY MAIN RUNNERS AND POSITIVELY ATTACHED WITH SCREWS OR OTHER APPROVED CONNECTORS.
c. SURFACE MOUNTED FIXTURES SHALL BE ATTACHED TO A MAIN RUNNER WITH A POSITIVE CLAMPING DEVICE MADE OF MATERIAL WITH A MINIMUM OF 14 GAGE. ROTATIONAL SPRING CLAMPS DO NOT COMPLY.

d. ACCESS PANELS: ACCESS TO THE SPACE BETWEEN THE CEILING AND THE FLOOR OR ROOF ABOVE SHALL NOT BE ALLOWED. SMALL ACCESS PANELS FOR THE INSPECTION, ADJUSTMENT, OR REPAIR OF UTILITY SWITCHES, VALVES, SENSORS, ETC. MAY BE ALLOWED IF THE PANEL IS LESS THAN 300 SQUARE INCHES. SUCH PANELS SHALL ALSO HAVE A PERMANENT WARNING LABEL AS FOLLOWS:
WARNING: 1. DO NOT CLIMB, WALK, OR CRAWL ON THE GYPSUM BOARD CEILING.
2. DO NOT STORE OR STOW ANYTHING ON THE GYPSUM BOARD CEILING.

e. ALL LIGHT FIXTURES WEIGHING LESS THAN OR EQUAL TO 10 LB. SHALL HAVE ONE NO. 12 GAUGE SAFETY WIRE CONNECTED FROM FIXTURE HOUSING TO STRUCTURE ABOVE. IT IS NOT NECESSARY FOR THESE SAFETY WIRES TO BE TAUT.

f. ALL FIXTURES WEIGHING GREATER THAN 10 LB BUT LESS THAN OR EQUAL TO 56 LB. SHALL HAVE TWO NO. 12 GAUGE SAFETY WIRES CONNECTED FROM FIXTURE HOUSING TO STRUCTURE ABOVE. IT IS NOT NECESSARY FOR THESE SAFETY WIRES TO BE TAUT.

g. ALL FIXTURES WEIGHING GREATER THAN 56 LB. SHALL BE SUPPORTED DIRECTLY FROM STRUCTURE ABOVE BY APPROVED HANGERS.

h. PENDENT-HUNG FIXTURES SHALL BE SUPPORTED DIRECTLY FROM THE STRUCTURE ABOVE USING NO LESS THAN NO. 9-GAUGE WIRE OR AN APPROVED ALTERNATE SUPPORT. THE CEILING SUSPENSION SYSTEM SHALL NOT PROVIDE ANY DIRECT SUPPORT.

i. ALL RECESSED OR DROP-IN FIXTURES SHALL BE SUPPORTED DIRECTLY FROM FIXTURE HOUSING TO THE STRUCTURE ABOVE WITH A MINIMUM OF TWO NO. 12 GAUGE WIRES LOCATED AT DIAGONALLY OPPOSITE CORNERS. LEVELLING OR POSITIONING OF FIXTURES MAY BE PROVIDED BY CEILING GRID. FIXTURE SUPPORT WIRES MAY BE SLIGHTLY LOOSE TO ALLOW THE FIXTURE TO SEAT IN THE GRID SYSTEM. FIXTURES SHALL NOT BE SUPPORTED FROM MAIN RUNNERS OR FURRING CHANNELS IF THE WEIGHT OF THE FIXTURES CAUSES TOTAL DEAD LOAD TO EXCEED THE DEFLECTION CAPABILITY OF THE CEILING SUSPENSION SYSTEM.

16. CEILINGS THAT ARE PART OF A FIRE RATED ASSEMBLY: PROVIDE A DETAIL AND DESIGN NUMBER FOR RATED CEILING ASSEMBLIES FROM AN APPROVED TESTING AGENCY. THE COMPONENTS AND INSTALLATION DETAILS SHALL CONFORM IN EVERY RESPECT WITH THE LISTED DETAIL AND NUMBER. DETAILS SHALL CLEARLY DEPICT ALL COMPONENTS, INCLUDING INSULATION MATERIALS, FRAMING AND ATTACHMENT OF THE DESIGN, SO THAT THE ASSEMBLY CAN BE CONSTRUCTED AND INSPECTED ACCORDINGLY. POP RIVETS, SCREWS, OR OTHER ATTACHMENTS ARE NOT ACCEPTABLE UNLESS SPECIFICALLY DETAILED ON THE DRAWINGS AND APPROVED BY OSHPD.

Section Title : OSHPD STANDARD GYPSUM BOARD CEILING DETAILS OPD No.
Sheet Title : GYP-BOARD SUSPENDED CEILING PAGE 4 OF 5 CG0.03

05/11/2017 OPD-0003-13: Reviewed for Code Compliance by Karim Page 28 of 75

5/9/2017 9:07:21 AM

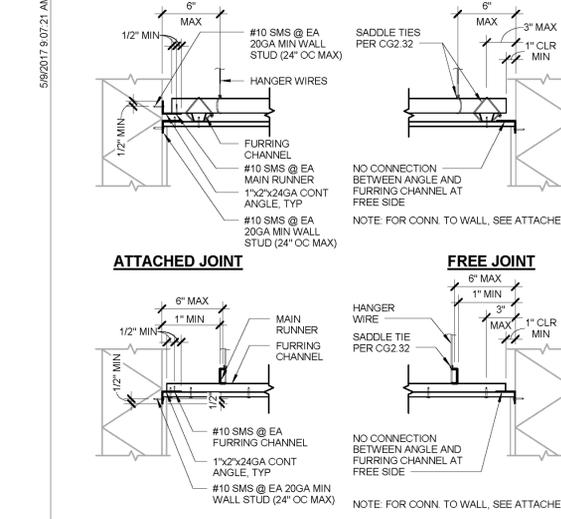

- NOTES:
1. PERIMETER WALLS SHALL BE DESIGNED TO CARRY TRIBUTARY LATERAL FORCES PER TABLE BELOW. RDP TO VERIFY RDP TO SPECIFY CONNECTION OF BACKING TO STUDS.
2. WHEN GYPSUM BOARD IS TO BE APPLIED TO BOTH CEILING AND WALLS, GYPSUM BOARD SHALL BE APPLIED FIRST TO THE CEILING AND THEN TO WALLS IN ACCORDANCE WITH ASTM C840.

Table with columns Sreq (lb) and Fp. Values: Sreq ≤ 1.15, 9.3 pif; 1.15 < Sreq ≤ 1.73, 14.0 pif; 1.73 < Sreq ≤ 2.50, 20.9 pif.

Section Title : OSHPD STANDARD GYPSUM BOARD CEILING DETAILS OPD No.
Sheet Title : CEILING PERIMETER CG2.30

05/11/2017 OPD-0003-13: Reviewed for Code Compliance by Karim Page 34 of 75

5/9/2017 9:07:20 AM

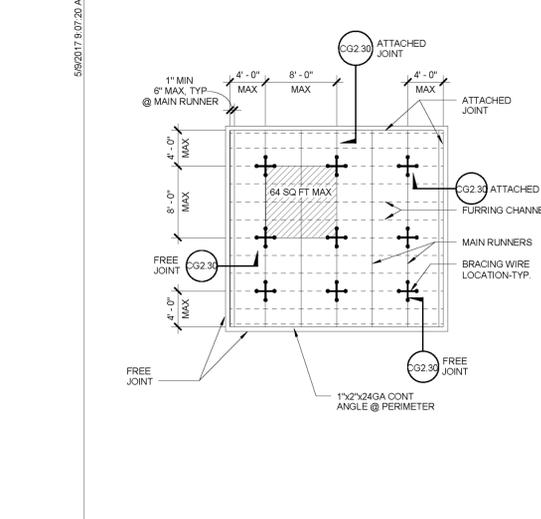

- NOTES:
1. BRACING WIRES AND COMP. STRUT SHALL OCCUR AT EVERY 64 SQ. FT. MAX. IN ROOMS OVER 64 SQ. FT.
2. RDP MAY ELECT TO SPECIFY TIGHTER SPACING BETWEEN BRACING WIRES AND COMP. STRUTS TO ALLOW SMALLER ANCHORS PER SCHEDULES ON SHEETS CG4.31 & CG6.80.

Section Title : OSHPD STANDARD GYPSUM BOARD CEILING DETAILS OPD No.
Sheet Title : TYPICAL CEILING PLAN FOR 17.3 < Sreq <= 2.50 AND z/h <= 1.0 CG2.20

05/11/2017 OPD-0003-13: Reviewed for Code Compliance by Karim Page 31 of 75

PROJECT MANAGEMENT

ALAMEIDA ARCHITECTURE

CONSTRUCTION MANAGEMENT

555 S. MAIN STREET, SUITE 2 SEBASTOPOL, CA 95472 (707) 824-1219 WWW.ALAMEIDA.COM



PROJECT TENANT IMPROVEMENTS FOR ECONOMIC DEVELOPMENT AND CHILD SUPPORT SERVICES

2420 6TH STREET EUREKA, CA



Table with columns No., Description, Date. Row 1: PLAN CHECK COMMENTS, 12/12/22.

SUSPENDED DRYWALL LAYOUT

Table with columns Project number, Date, Drawn by, Checked by. Values: 2108, 5/8/22, Author, Checker.

A-7.2

5/2/2023 4:54:58 PM

2019 CALIFORNIA GREEN BUILDING STANDARDS CODE
NONRESIDENTIAL MANDATORY MEASURES, SHEET 1 (January 2020, Includes August 2019 Supplement)

Y N/A RESPON PARTY ; YES NOT APPLICABLE RESPONSIBLE PARTY (i.e. ARCHITECT, ENGINEER, OWNER, CONTRACTOR, INSPECTOR ETC.)

PROJECT MANAGEMENT

ALAMEIDA ARCHITECTURE

CONSTRUCTION MANAGEMENT

555 S. MAIN STREET, SUITE 2
SEBASTOPOL, CA 95472
(707) 824-1219
WWW.ALAMEIDA.COM



PROJECT

TENANT IMPROVEMENTS FOR ECONOMIC DEVELOPMENT AND CHILD SUPPORT SERVICES

2420 6TH STREET
EUREKA, CA

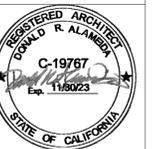

No. Description Date

1. PLAN CHECK COMMENTS 12/12/22

Table with 3 columns: No., Description, Date. Row 1: 1. PLAN CHECK COMMENTS 12/12/22

CAL GREEN CHECKLIST

Project number 2108
Date 5/8/22
Drawn by Author
Checked by Checker

CG-1

Scale

CHAPTER 3 GREEN BUILDING SECTION 301 GENERAL

301.1 SCOPE. Buildings shall be designed to include the green building measures specified as mandatory in the application checklists contained in this code.

301.3 NONRESIDENTIAL ADDITIONS AND ALTERATIONS. [BSC-CG] The provisions of individual sections of Chapter 3 apply to newly constructed buildings, building additions of 1,000 square feet or greater, and/or building alterations with a permit valuation of \$200,000 or above.

A code section will be designated by a banner to indicate where the code section only applies to newly constructed buildings [N] or to additions and/or alterations [A].

301.3.1 Nonresidential additions and alterations that cause updates to plumbing fixtures only:

Note: On and after January 1, 2014, certain commercial real property, as defined in Civil Code Section 1101.3, shall have its noncompliant plumbing fixtures replaced with appropriate water-conserving plumbing fixtures under specific circumstances.

301.3.2 Waste Diversion. The requirements of Section 5.408 shall be required for additions and alterations whenever a permit is required for work.

301.4 PUBLIC SCHOOLS AND COMMUNITY COLLEGES. (see GBSC)
301.5 HEALTH FACILITIES. (see GBSC)

SECTION 302 MIXED OCCUPANCY BUILDINGS

302.1 MIXED OCCUPANCY BUILDINGS. In mixed occupancy buildings, each portion of a building shall comply with the specific green building measures applicable to each specific occupancy.

SECTION 303 PHASED PROJECTS

303.1 PHASED PROJECTS. For shell buildings and others constructed for future tenant improvements, only those code measures relevant to the building components and systems considered to be new construction (or newly constructed) shall apply.

303.1.1 Initial Tenant Improvements. The provisions of this code shall apply only to the initial tenant improvements to a project. Subsequent tenant improvements shall comply with the scoping provisions in Section 301.3 non-residential additions and alterations.

ABBREVIATION DEFINITIONS:

- HCD Department of Housing and Community Development
BSC California Building Standards Commission
DSA-SS Division of the State Architect, Structural Safety
OSHPD Office of Statewide Health Planning and Development
LR Low Rise
HR High Rise
AA Additions and Alterations
N New

CHAPTER 5 NONRESIDENTIAL MANDATORY MEASURES

DIVISION 5.1 PLANNING AND DESIGN

SECTION 5.101 GENERAL

5.101.1 SCOPE. The provisions of this chapter outline planning, design and development methods that include environmentally responsible site selection, building design, building siting and development to protect, restore and enhance the environmental quality of the site and preserve the integrity of adjacent properties.

SECTION 5.102 DEFINITIONS

5.102.1 DEFINITIONS. The following terms are defined in Chapter 2 (and are included here for reference)

CUTOFF LUMINAIRES. Luminaires whose light distribution is such that the candela per 1000 lamp lumens does not numerically exceed 25 (2.5 percent) at an angle of 90 degrees above nadir, and 100 (10 percent) at a vertical angle of 90 degrees above nadir. This applies to all lateral angles around the luminaire.

LOW-EMITTING AND FUEL EFFICIENT VEHICLES.

- Eligible vehicles are limited to the following:
1. Zero emission vehicle (ZEV), including neighborhood electric vehicles (NEV), partial zero emission vehicle (PZEV), advanced technology PZEV (AT ZEV) or CNG fueled (original equipment manufacturer only) regulated under Health and Safety Code section 43800 and CCR, Title 13, Sections 1961 and 1962.
2. High-efficiency vehicles, regulated by U.S. EPA, bearing High-Occupancy Vehicle (HOV) car pool lane stickers issued by the Department of Motor Vehicles.

NEIGHBORHOOD ELECTRIC VEHICLE (NEV). A motor vehicle that meets the definition of "low-speed vehicle" either in Section 385.5 of the Vehicle Code or in 49CFR571.500 (as it existed on July 1, 2000), and is certified to zero-emission vehicle standards.

TENANT-OCCUPANTS. Building occupants who inhabit a building during its normal hours of operation as permanent occupants, such as employees, as distinguished from customers and other transient visitors.

VANPOOL VEHICLE. Eligible vehicles are limited to any motor vehicle, other than a motortruck or truck tractor, designed for carrying more than 10 but not more than 15 persons including the driver, which is maintained and used primarily for the nonprofit work-related transportation of adults for the purpose of ridesharing.

Note: Source: Vehicle Code, Division 1, Section 668

SECTION 5.106 SITE DEVELOPMENT

5.106.1 STORM WATER POLLUTION PREVENTION FOR PROJECTS THAT DISTURB LESS THAN ONE ACRE OF LAND.

Newly constructed projects and additions which disturb less than one acre of land, and are not part of a larger common plan of development or sale, shall prevent the pollution of storm water runoff from the construction activities through one or more of the following measures:

5.106.1.1 Local ordinance. Comply with a lawfully enacted storm water management and/or erosion control ordinance.

5.106.1.2 Best Management Practices (BMPs). Prevent the loss of soil through wind or water erosion by implementing an effective combination of erosion and sediment control and good housekeeping BMPs.

- 1. Soil loss BMPs that should be considered for implementation as appropriate for each project include, but are not limited to, the following:
a. Scheduling construction activity during dry weather, when possible.
b. Preservation of natural features, vegetation, soil, and buffers around surface waters.
c. Drainage swales or lined ditches to control stormwater flow.
d. Mulching or hydrosediment to stabilize disturbed soils.
e. Erosion control to protect slopes.
f. Protection of storm drain inlets (gravel bags or catch basin inlets).
g. Perimeter sediment control (perimeter silt fence, fiber rolls).
h. Sediment trap or sediment basin to retain sediment on site.
i. Stabilized construction exits.
j. Wind erosion control.
k. Other soil loss BMPs acceptable to the enforcing agency.
2. Good housekeeping BMPs to manage construction equipment, materials, non-stormwater discharges and wastes that should be considered for implementation as appropriate for each project include, but are not limited to, the following:
a. Dewatering activities.
b. Material handling and waste management.
c. Building materials stockpile management.
d. Management of washout areas (concrete, paints, stucco, etc.).
e. Control of vehicle/equipment fueling to contractor's staging area.
f. Vehicle and equipment cleaning performed off site.
g. Soil prevention and control.
h. Other housekeeping BMPs acceptable to the enforcing agency.

5.106.2 STORMWATER POLLUTION PREVENTION FOR PROJECTS THAT DISTURB ONE OR MORE ACRES OF LAND.

Projects that (1) disturb one acre or more of land, or (2) disturb less than one acre of land but are part of a larger common plan of development sale.

Note: Projects that (1) disturb one acre or more of land, or (2) disturb less than one acre of land but are part of the larger common plan of development or sale must comply with the post-construction stormwater management measures detailed in the applicable National Pollutant Discharge Elimination System (NPDES) General permit for Stormwater Discharges Associated with Construction and Land Disturbance Activities issued by the State Water Resources Control Board or the Lahontan Regional Water Quality Control Board (for projects in the Lake Tahoe Hydrologic Unit).

The NPDES permits require postconstruction runoff (post-project hydrology) to match the preconstruction runoff (pre-project hydrology) with the installation of postconstruction stormwater management measures.

Refer to the current applicable permits on the State Water Resources Control Board website at: www.waterboards.ca.gov/constructionstormwater. Consideration to the stormwater runoff management measures should be given during the initial design process for appropriate integration into site development.

5.106.4 BICYCLE PARKING. For buildings within the authority of California Building Standards Commission as specified in Section 103, comply with Section 5.106.4.1. For buildings within the authority of the Division of the State Architect pursuant to Section 105, comply with Section 5.106.4.2

5.106.4.1 Bicycle parking. [BSC-CG] Comply with Sections 5.106.4.1.1 and 5.106.4.1.2; or meet the applicable local ordinance, whichever is stricter.

5.106.4.1.1 Short-term bicycle parking. If the new project or an addition or alteration is anticipated to generate visitor traffic, provide permanently anchored bicycle racks within 200 feet of the visitors' entrance, readily visible to passers-by, for 5% of new visitor motorized vehicle parking spaces being added, with a minimum of one two-bike capacity rack.

5.106.4.1.2 Long-term bicycle parking. For new buildings with tenant spaces that have 10 or more tenant-occupants, provide secure bicycle parking for 5 percent of the tenant-occupant vehicular parking spaces with a minimum of one bicycle parking facility.

5.106.4.1.3 For additions or alterations that add 10 or more tenant-occupant vehicular parking spaces, provide secure bicycle parking for 5 percent of the tenant vehicular parking spaces being added, with a minimum of one bicycle parking facility.

5.106.4.1.4 For new shell buildings in phased projects provide secure bicycle parking for 5 percent of the anticipated tenant-occupant vehicular parking spaces with a minimum of one bicycle parking facility.

5.106.4.1.5 Acceptable bicycle parking facility for Sections 5.106.4.1.2, 5.106.4.1.3, and 5.106.4.1.4 shall be convenient from the street and shall meet one of the following:

- 1. Covered, lockable enclosures with permanently anchored racks for bicycles;
2. Lockable bicycle rooms with permanently anchored racks; or
3. Lockable, permanently anchored bicycle lockers.

Note: Additional information on recommended bicycle accommodations may be obtained from Sacramento Area Bicycle Advocates.

5.106.4.2 Bicycle parking. [DSA-SS] For public schools and community colleges, comply with Sections 5.106.4.2.1 and 5.106.4.2.2

5.106.4.2.1 Student bicycle parking. Provide permanently anchored bicycle racks conveniently accessed with a minimum of four two-bike capacity racks per new building.

5.106.4.2.2 Staff bicycle parking. Provide permanent, secure bicycle parking conveniently accessed with a minimum of two staff bicycle parking spaces per new building.

5.106.5.2 DESIGNATED PARKING FOR CLEAN AIR VEHICLES. In new projects or additions or alterations that add 10 or more vehicular parking spaces, provide designated parking for any combination of low-emitting, fuel-efficient and carpool/van pool vehicles as follows:

Table 5.106.5.2 - PARKING. Columns: TOTAL NUMBER OF PARKING SPACES, NUMBER OF REQUIRED SPACES. Rows: 0-9, 10-25, 26-50, 51-75, 76-100, 101-150, 151-200, 201 AND OVER (AT LEAST 8% OF TOTAL).

5.106.5.2.1 - Parking stall marking. Paint, in the paint used for stall striping, the following characters such that the lower edge of the last word aligns with the end of the stall striping and is visible beneath a parked vehicle: CLEAN AIR / VAN POOL / EV

Note: Vehicles bearing Clean Air Vehicle stickers from expired HOV lane programs may be considered eligible for designated parking spaces.

5.106.5.3 Electric vehicle (EV) charging. [N] Construction shall comply with Section 5.106.5.3.1 or Section 5.106.5.3.2 to facilitate future installation of electric vehicle supply equipment (EVSE). When EVSE(s) are installed, it shall be in accordance with the California Building Code, the California Electrical Code and as follows:

5.106.5.3.1 Single charging space requirements. [N] When only a single charging space is required per Table 5.106.5.3.3, a raceway is required to be installed at the time of construction and shall be installed in accordance with the California Electrical Code. Construction plans and specifications shall include, but are not limited to, the following:

- 1. The type and location of the EVSE.
2. A listed raceway capable of accommodating a 208/240-volt dedicated branch circuit.
3. The raceway shall not be less than trade size 1".
4. The raceway shall originate at a service panel or a subpanel serving the area, and shall terminate in close proximity to the proposed location of the charging equipment and listed suitable cabinet, box, enclosure or equivalent.
5. The service panel or subpanel shall have sufficient capacity to accommodate a minimum 40-ampere dedicated branch circuit for the future installation of the EVSE.

5.106.5.3.2 Multiple charging space requirements. [N] When multiple charging spaces are required per Table 5.106.5.3.3, raceway(s) is/are required to be installed at the time of construction and shall be installed in accordance with the California Electrical Code. Construction plans and specifications shall include, but are not limited to, the following:

- 1. The type and location of the EVSE.
2. The raceway(s) shall originate at a service panel or a subpanel(s) serving the area, and shall terminate in close proximity to the proposed location of the charging equipment and into listed suitable cabinet(s), box(es), enclosure(s) or equivalent.
3. Plan design shall be based upon 40-ampere minimum branch circuits.
4. Electrical calculations shall substantiate the design of the electrical system, to include the rating of equipment and any on-site distribution transformers and have sufficient capacity to simultaneously charge all required EVs at its full rated amperage.
5. The service panel or subpanel(s) shall have sufficient capacity to accommodate the required number of dedicated branch circuit(s) for the future installation of the EVSE.

5.106.5.3.3 EV charging space calculations. [N] Table 5.106.5.3.3 shall be used to determine if single or multiple charging space requirements apply for the future installation of EVSE.

Exceptions: On a case-by-case basis where the local enforcing agency has determined EV charging and infrastructure is not feasible based upon one or more of the following conditions:

- 1. Where there is insufficient electrical supply.
2. Where there is evidence available to the local enforcing agency substantiating that additional local utility infrastructure design requirements, directly related to the implementation of Section 5.106.5.3, may adversely impact the construction cost of the project.

Table 5.106.5.3.3. Columns: TOTAL NUMBER OF PARKING SPACES, NUMBER OF REQUIRED SPACES. Rows: 0-9, 10-25, 26-50, 51-75, 76-100, 101-150, 151-200, 201 AND OVER (8% of total).

1. Calculation for spaces shall be rounded up to the nearest whole number.

5.106.5.3.4 [N] Identification. The service panel or subpanel(s) circuit directory shall identify the reserved overcurrent protective device space(s) for future EV charging as "EV CAPABLE".

5.106.5.3.5 [N] Future charging spaces qualify as designated parking as described in Section 5.106.5.2 Designated parking for clean air vehicles.

5.106.8 LIGHT POLLUTION REDUCTION. [N.] Outdoor lighting systems shall be designed and installed to comply with the following:

- 1. The minimum requirements in the California Energy Code for Lighting Zones 0-4 as defined in Chapter 10, Section 10-114 of the California Administrative Code; and
2. Backlight (B) ratings as defined in IES TM-15-11 (shown in Table A-1 in Chapter 8);
3. Uplight and Glare ratings as defined in California Energy Code (shown in Tables 130.2-A and 130.2-B in Chapter 8) and
4. Allowable BUG ratings not exceeding those shown in Table 5.106.8. [N] or Comply with a local ordinance lawfully enacted pursuant to Section 101.7, whichever is more stringent.

Exceptions: [N]

- 1. Luminaires that qualify as exceptions in Section 140.7 of the California Energy Code.
2. Emergency lighting.
3. Building facade meeting the requirements in Table 140.7-B of the California Energy Code, Part 6.
4. Custom lighting features as allowed by the local enforcing agency, as permitted by Section 101.8 Alternate materials, designs and methods of construction.

Note: [N]
1. See also California Building Code, Chapter 12, Section 1205.6 for college campus lighting requirements for parking facilities and walkways.
2. Refer to Chapter 8 (Compliance Forms, Worksheets and Reference Material) for IES TM-15-11 Table A-1, California Energy Code Tables 130.2-A and 130.2-B.
3. Refer to the California Building Code for requirements for additions and alterations.

TABLE 5.106.8 [N] MAXIMUM ALLOWABLE BACKLIGHT, UPLIGHT AND GLARE (BUG) RATINGS

Table with 6 columns: ALLOWABLE RATING, LIGHTING ZONE L20, LIGHTING ZONE L21, LIGHTING ZONE L22, LIGHTING ZONE L23, LIGHTING ZONE L24. Rows include MAXIMUM ALLOWABLE BACKLIGHT RATING, MAXIMUM ALLOWABLE GLARE RATING (G), and For areas lighting - U.

1. IESNA Lighting Zones 0 and 5 are not applicable; refer to Lighting Zones as defined in the California Energy Code and Chapter 10 of the California Administrative Code.

2. For property lines that abut public walkways, bikeways, plazas and parking lots, the property line may be considered to be 5 feet beyond the actual property line for purpose of determining compliance with this section.

3. If the nearest property line is less than or equal to two mounting heights from the back hemisphere of the luminaire distribution, the applicable reduced Backlight rating shall be met.

4. General lighting luminaires in areas such as outdoor parking, sales or storage lots shall meet these reduced ratings. Decorative luminaires located in these areas shall meet U-value limits for "all other outdoor lighting".

5. If the nearest property line is less than or equal to two mounting heights from the front hemisphere of the luminaire distribution, the applicable reduced Glare rating shall be met.

5.106.10 GRADING AND PAVING. Construction plans shall indicate how site grading or a drainage system will manage all surface water flows to keep water from entering buildings. Examples of methods to manage surface water include, but are not limited to, the following:

- 1. Swales.
2. Water collection and disposal systems.
3. French drains.
4. Water retention gardens.
5. Other water measures which keep surface water away from buildings and aid in groundwater recharge.
Exception: Additions and alterations not altering the drainage path.

5.106.12 SHADE TREES [DSA-SS]. Shade Trees shall be planted to comply with Sections 5.106.12.1, 5.106.12.2, and 5.106.12.3. Percentages shown shall be measured at noon on the summer solstice.

5.106.12.1 Surface parking areas. Shade tree plantings, minimum #10 container size or equal, shall be installed to provide shade over 50 percent of the parking area within 15 years.

Exceptions: The surface parking area covered by solar photovoltaic shade structures, or shade structures, with roofing materials that comply with Table A5.106.11.2.2 in Appendix A5, are not included in the total area calculations.

5.106.12.2 Landscape areas. Shade tree plantings, minimum #10 container size or equal shall be installed to provide shade of 20% of the landscape area within 15 years.

Exceptions: Playfields for organized sport activity are not included in the total area calculation.

5.106.12.3. Hardscapes areas. Shade tree plantings, minimum #10 container size or equal shall be installed to provide shade over 20 percent of the hardscapes area within 15 years.

Exceptions: Walks, hardscapes areas covered by solar photovoltaic shade structures, and hardscapes areas covered by shade structures with roofing materials that comply with Table A5.106.11.2.2 in Appendix A5, are not included in the total area calculation.

DIVISION 5.2 ENERGY EFFICIENCY

SECTION 5.201 GENERAL

5.201.1 Scope [BSC-CG]. California Energy Code [DSA-SS]. For the purposes of mandatory energy efficiency standards in this code, the California Energy Commission will continue to adopt mandatory building standards.

DIVISION 5.3 WATER EFFICIENCY AND CONSERVATION

SECTION 5.301 GENERAL

5.301.1 Scope. The provisions of this chapter shall establish the means of conserving water use indoors, outdoors and in wastewater conveyance.

SECTION 5.302 DEFINITIONS

5.302.1 Definitions. The following terms are defined in Chapter 2 (and are included here for reference)

EVAPOTRANSPIRATION ADJUSTMENT FACTOR (ETA) [DSA-SS]. An adjustment factor when applied to reference evapotranspiration that adjusts for plant factors and irrigation efficiency, which as two major influences on the amount of water that needs to be applied to the landscape.

FOOTPRINT AREA [DSA-SS]. The total area of the furthest exterior wall of the structure projected to natural grade, not including exterior areas such as stairs, covered walkways, patios and decks.

METERING FAUCET. A self-closing faucet that dispenses a specific volume of water for each actuation cycle. The volume or cycle duration can be fixed or adjustable.

GRAYWATER. Pursuant to Health and Safety Code Section 17922.12, "graywater" means untreated wastewater that has not been contaminated by any toilet discharge, has not been affected by infectious, contaminated, or unhealthy body wastes, and does not present a threat from contamination by unhealthful processing, manufacturing, or operating wastes. "Graywater" includes, but is not limited to wastewater from bathtubs, showers, bathroom washbasins, clothes washing machines and laundry tubs, but does not include waste water from kitchen sinks or dishwashers.

MODEL WATER EFFICIENT LANDSCAPE ORDINANCE (MWELO). The California ordinance regulating landscape design, installation and maintenance practices that will ensure commercial, multifamily and other developer installed landscapes greater than 2500 square feet meet an irrigation water budget developed based on landscaped area and climatological parameters.

MODEL WATER EFFICIENT LANDSCAPE ORDINANCE (MWELO). [HCD] The California model ordinance (California Code of Regulations, Title 23, Division 2, Chapter 2.7), regulating landscape design, installation and maintenance practices. Local agencies are required to adopt the updated MWELO, or adopt a local ordinance at least as effective as the MWELO.

POTABLE WATER. Water that is drinkable and meets the U.S. Environmental Protection Agency (EPA) Drinking Water Standards. See definition in the California Plumbing Code, Part 5.

POTABLE WATER [HCD] Water that is satisfactory for drinking, culinary, and domestic purposes, and meets the U.S. Environmental Protection Agency (EPA) Drinking Water Standards and the requirements of the Health Authority Having Jurisdiction.

RECYCLED WATER. Water which, as a result of treatment of waste, is suitable for a direct beneficial use or a controlled use that would not otherwise occur [Water Code Section 13050 (n)]. Simply put, recycled water is water treated to remove waste matter attaining a quality that is suitable to use the water again.

SUBMETER. A meter installed subordinate to a site meter. Usually used to measure water intended for one purpose, such as landscape irrigation. For the purposes of CALGreen, a dedicated meter may be considered a submeter.

WATER BUDGET. Is the estimated total landscape irrigation water use which shall not exceed the maximum allowed water allowance calculated in accordance with the Department of Water Resources Model Efficient Landscape Ordinance (MWELO).

SECTION 5.303 INDOOR WATER USE

5.303.1 METERS. Separate submeters or metering devices shall be installed for the uses described in Sections 503.1.1 and 503.1.2.

5.303.1.1 Buildings in excess of 50,000 square feet. Separate submeters shall be installed as follows:

- 1. For each individual leased, rented or other tenant space within the building projected to consume more than 100 gal/day (380 L/day), including, but not limited to, spaces used for laundry or cleaners, restaurant or food service, medical or dental office, laboratory, or beauty salon or barber shop.
2. Where separate submeters for individual building tenants are unfeasible, for water supplied to the following subsystems:
a. Makeup water for cooling towers where flow through is greater than 500 gpm (30 L/s).
b. Makeup water for evaporative coolers greater than 6 gpm (0.04 L/s).
c. Steam and hot water boilers with energy input more than 500,000 Btu/h (147 kW).

5.303.1.2 Excess consumption. A separate submeter or metering device shall be provided for any tenant within a new building or within an addition that is projected to consume more than 1,000 gal/day.

5.303.3 WATER CONSERVING PLUMBING FIXTURES AND FITTINGS. Plumbing fixtures (water closets and urinals) and fittings (faucets and showerheads) shall comply with the following:

5.303.3.1 Water Closets. The effective flush volume of all water closets shall not exceed 1.28 gallons per flush. Tank-type water closets shall be certified to the performance criteria of the U.S. EPA WaterSense Specification for Tank-Type toilets.

Note: The effective flush volume of dual flush toilets is defined as the composite, average flush volume of two reduced flushes and one full flush.

5.303.3.2 Urinals.
5.303.3.2.1 Wall-mounted Urinals. The effective flush volume of wall-mounted urinals shall not exceed 0.125 gallons per flush.
5.303.3.2.2 Floor-mounted Urinals. The effective flush volume of floor-mounted or other urinals shall not exceed 0.5 gallons per flush.

5.303.3.3 Showerheads. [BSC-CG]
5.303.3.3.1 Single showerhead. Showerheads shall have a maximum flow rate of not more than 1.8 gallons per minute at 80 psi. Showerheads shall be certified to the performance criteria of the U.S. EPA WaterSense Specification for Showerheads.

5.303.3.3.2 Multiple showerheads serving one shower. When a shower is served by more than one showerhead, the combined flow rate of all the showerheads and/or other shower outlets controlled by a single valve shall not exceed 1.8 gallons per minute at 80 psi, or the shower shall be designed to allow only one shower outlet to be in operation at a time.
Note: A hand-held shower shall be considered a showerhead.

5.303.3.3.3 Multiple showerheads serving one shower. When a shower is served by more than one showerhead, the combined flow rate of all the showerheads and/or other shower outlets controlled by a single valve shall not exceed 1.8 gallons per minute at 80 psi, or the shower shall be designed to allow only one shower outlet to be in operation at a time.
Note: A hand-held shower shall be considered a showerhead.

2019 CALIFORNIA GREEN BUILDING STANDARDS CODE
NONRESIDENTIAL MANDATORY MEASURES, SHEET 1 (January 2020, Includes August 2019 Supplement)

Y NA RESPON. PARTY
YES NOT APPLICABLE RESPONSIBLE PARTY (i.e. ARCHITECT, ENGINEER, OWNER, CONTRACTOR, INSPECTOR, ETC.)

Main table with columns for Y/NA/RESPON. PARTY and content for various sections including 5.303.3.4 Faucets and fountains, 5.407 WATER RESISTANCE AND MOISTURE MANAGEMENT, 5.408 CONSTRUCTION WASTE REDUCTION, DISPOSAL AND RECYCLING, 5.410.2 COMMISSIONING, and 5.410.4 TESTING AND ADJUSTING.

PROJECT MANAGEMENT
ALAMEIDA ARCHITECTURE
CONSTRUCTION MANAGEMENT
555 S. MAIN STREET, SUITE 2
SEBASTOPOL, CA 95472
(707) 824-1219
WWW.ALAMEIDA.COM



TENANT IMPROVEMENTS FOR ECONOMIC DEVELOPMENT AND CHILD SUPPORT SERVICES
2420 6TH STREET
EUREKA, CA

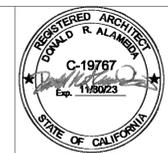

Table with 3 columns: No., Description, Date. Row 1: PLAN CHECK COMMENTS, 12/12/22.

CALGREEN CHECKLIST

Table with 3 columns: Project number, Date, Drawn by, Checked by. Values: 2108, 5/8/22, Author, Checker.

2019 CALIFORNIA GREEN BUILDING STANDARDS CODE
NONRESIDENTIAL MANDATORY MEASURES, SHEET 1 (January 2020, Includes August 2019 Supplement)

Table with 2 columns: Y, N/A RESPON. PARTY. Row 1: X, G.C.

5.504.4 FINISH MATERIAL POLLUTANT CONTROL. Finish materials shall comply with Sections 5.504.4.1 through 5.504.4.6.

- 5.504.4.1 Adhesives, sealants and caulks. Adhesives, sealants, and caulks used on the project shall meet the requirements of the following standards:
1. Adhesives, adhesive bonding primers, adhesive primers, sealants, sealant primers and caulks shall comply with local or regional air pollution control or air quality management district rules where applicable, or SCAGMD Rule 1168 VOC limits, as shown in Tables 5.504.4.1 and 5.504.4.2. Such products also shall comply with the Rule 1168 prohibition on the use of certain toxic compounds (chloroform, ethylene dichloride, methylene chloride, perchloroethylene and trichloroethylene), except for aerosol products as specified in subsection 2, below.
2. Aerosol adhesives, and smaller unit sizes of adhesives, and sealant or caulking compounds (in units of product, less packaging, which do not weigh more than one pound and do not consist of more than 16 fluid ounces) shall comply with statewide VOC standards and other requirements, including prohibitions on use of certain toxic compounds, of California Code of Regulations, Title 17, commencing with Section 94507.

TABLE 5.504.4.1 - ADHESIVE VOC LIMIT_{1,2}

Table with 2 columns: ARCHITECTURAL APPLICATIONS, CURRENT VOC LIMIT. Lists various adhesive types and their corresponding VOC limits.

- 1. IF AN ADHESIVE IS USED TO BOND DISSIMILAR SUBSTRATES TOGETHER, THE ADHESIVE WITH THE HIGHEST VOC CONTENT SHALL BE ALLOWED.
2. FOR ADDITIONAL INFORMATION REGARDING METHODS TO MEASURE THE VOC CONTENT SPECIFIED IN THIS TABLE, SEE SOUTH COAST AIR QUALITY MANAGEMENT DISTRICT RULE 1168, www.arb.ca.gov/DRDB/SCUR/HTMLR1168.PDF

TABLE 5.504.4.2 - SEALANT VOC LIMIT

Table with 2 columns: SEALANTS, CURRENT VOC LIMIT. Lists sealant types and their VOC limits.

NOTE: FOR ADDITIONAL INFORMATION REGARDING METHODS TO MEASURE THE VOC CONTENT SPECIFIED IN THESE TABLES, SEE SOUTH COAST AIR QUALITY MANAGEMENT DISTRICT RULE 1168.

5.504.4.3 Paints and coatings. Architectural paints and coatings shall comply with VOC limits in Table 1 of the ARB Architectural Coatings Suggested Control Measure, as shown in Table 5.504.4.3, unless more stringent local limits apply. The VOC content limit for coatings that do not meet the definitions for the specialty coatings categories listed in Table 5.504.4.3 shall be determined by classifying the coating as a Flat, Nonflat or Nonflat-High Gloss coating, based on its gloss, as defined in Subsections 4.21, 4.36 and 4.37 of the 2007 California Air Resources Board Suggested Control Measure, and the corresponding Flat, Nonflat or Nonflat-High Gloss VOC limit in Table 5.504.4.3 shall apply.

5.504.4.3.1 Aerosol Paints and coatings. Aerosol paints and coatings shall meet the PWMIR Limits for VOC in Section 94522(a)(3) and other requirements, including prohibitions on use of certain toxic compounds and ozone depleting substances, in Sections 94522(c)(2) and (d)(2) of California Code of Regulations, Title 17, commencing with Section 94520, and in areas under the jurisdiction of the Bay Area Air Quality Management District additionally comply with the percent VOC by weight of product limits of Regulation 8 Rule 49.

TABLE 5.504.4.3 - VOC CONTENT LIMITS FOR ARCHITECTURAL COATINGS_{1,2}

Table with 2 columns: COATING CATEGORY, CURRENT VOC LIMIT. Lists various coating types and their VOC limits.

- 1. GRAMS OF VOC PER LITER OF COATING, INCLUDING WATER & EXEMPT COMPOUNDS
2. THE SPECIFIED LIMITS REMAIN IN EFFECT UNLESS REVISED LIMITS ARE LISTED IN SUBSEQUENT COLUMNS IN THE TABLE.
3. VALUES IN THIS TABLE ARE DERIVED FROM THOSE SPECIFIED BY THE CALIFORNIA AIR RESOURCES BOARD, ARCHITECTURAL COATINGS SUGGESTED CONTROL MEASURE, FEB. 1, 2008. MORE INFORMATION IS AVAILABLE FROM THE AIR RESOURCES BOARD.

5.504.4.3.2 Verification. Verification of compliance with this section shall be provided at the request of the enforcing agency. Documentation may include, but is not limited to, the following:
1. Manufacturer's product specification
2. Field verification of on-site product containers

5.504.4.4 Carpet Systems. All carpet installed in the building interior shall meet at least one of the testing and product requirements:
1. Carpet and Rug Institute's Green Label Plus Program.
2. Compliant with the VOC-emission limits and testing requirements specified in the California Department of Public Health Standard Method for the Testing and Evaluation of Volatile Organic Chemical Emissions from Indoor Sources Using Environmental Chambers, Version 1.1, February 2010 (also known as CDPH Standard Method V1.1 or Specification 01350).
3. NSF/ANSI 140 at the Gold level or higher.
4. Scientific Certifications Systems Sustainable Choice; or
5. Compliant with the Collaborative for High Performance Schools California (2014 CA-CHPS) Criteria listed in the CHPS High Performance Product Database.

5.504.4.4.1 Carpet cushion. All carpet cushion installed in the building interior shall meet the requirements of the Carpet and Rug Institute Green Label program.

5.504.4.4.2 Carpet adhesive. All carpet adhesive shall meet the requirements of Table 5.504.4.1.

5.504.4.5 Composite wood products. Hardwood plywood, particleboard and medium density fiberboard composite wood products used on the interior or exterior of the buildings shall meet the requirements for formaldehyde as specified in ARB's Air Toxics Control Measure (ATCM) for Composite Wood (17 CCR 93120 et seq.). Those materials not exempted under the ATCM must meet the specified emission limits, as shown in Table 5.504.4.5.

5.504.4.5.3 Documentation. Verification of compliance with this section shall be provided as requested by the enforcing agency. Documentation shall include at least one of the following:

- 1. Product certifications and specifications.
2. Chain of custody certifications.
3. Product labeled and invoiced as meeting the Composite Wood Products regulation (see CCR, Title 17, Section 93120, et seq.).
4. Exterior grade products marked as meeting the PS-1 or PS-2 standards of the Engineered Wood Association, the Australian AS/NZS 2289 or European 636 3S standards.
5. Other methods acceptable to the enforcing agency.

Table with 2 columns: PRODUCT, CURRENT LIMIT. Lists formaldehyde emission limits for various products like plywood, particleboard, etc.

1. VALUES IN THIS TABLE ARE DERIVED FROM THOSE SPECIFIED BY THE CALIFORNIA AIR RESOURCES BOARD, AIR TOXICS CONTROL MEASURE FOR COMPOSITE WOOD AS TESTED IN ACCORDANCE WITH ASTM E 1333. FOR ADDITIONAL INFORMATION, SEE CALIFORNIA CODE OF REGULATIONS, TITLE 17, SECTIONS 93120 THROUGH 93120.12.
2. THIN MEDIUM DENSITY FIBERBOARD HAS A MAXIMUM THICKNESS OF 5/16 INCHES (8 MM).

5.504.4.6 Resilient flooring systems. For 80 percent of floor area receiving resilient flooring, installed resilient flooring shall meet at least one of the following:

- 1. Certified under the Resilient Floor Covering Institute (RFCI) FloorScore program;
2. Compliant with the VOC-emission limits and testing requirements specified in the California Department of Public Health's 2010 Standard Method for the Testing and Evaluation Chambers, Version 1.1, February 2010;
3. Compliant with the Collaborative for High Performance Schools California (2014 CA-CHPS) Criteria and listed in the CHPS High Performance Product Database; or
4. Products certified under UL GREENGUARD Gold (formerly the Greenguard Children's & Schools Program).

5.504.4.6.1 Verification of compliance. Documentation shall be provided verifying that resilient flooring materials meet the pollutant emission limits.

5.504.5.3 Filters. In mechanically ventilated buildings, provide regularly occupied areas of the building with air filtration media for outside and return air that provides at least a Minimum Efficiency Reporting Value (MERV) of 13. MERV 13 filters shall be installed prior to occupancy, and recommendations for maintenance with filters of the same value shall be included in the operation and maintenance manual.

5.504.5.3.1 Labeling. Installed filters shall be clearly labeled by the manufacturer indicating the MERV rating.

5.504.5.4 ENVIRONMENTAL TOBACCO SMOKE (ETS) CONTROL. Where outdoor areas are provided for smoking, prohibit smoking within 25 feet of building entries, outdoor air intakes and operable windows and within the building as already prohibited by other laws or regulations; or as enforced by ordinances, regulations or policies of any city, county, city and county, California Community College, campus of the California State University, or campus of the University of California, whichever are more stringent. When ordinances, regulations or policies are not in place, post signage to inform building occupants of the prohibitions.

SECTION 5.505 INDOOR MOISTURE CONTROL
5.505.1 INDOOR MOISTURE CONTROL. Buildings shall meet or exceed the provisions of California Building Code, CCB, Title 24, Part 2, Sections 1202 (Ventilation) and Chapter 14 (Exterior Walls). For additional measures, see Section 5.407.2 of this code.

SECTION 5.506 INDOOR AIR QUALITY
5.506.1 OUTSIDE AIR DELIVERY. For mechanically or naturally ventilated spaces in buildings, meet the minimum requirements of Section 120.1 (Requirements for Ventilation) of the California Energy Code, or the applicable local code, whichever is more stringent, and Division 1, Chapter 4 of CCR, Title 8.

5.506.2 CARBON DIOXIDE (CO2) MONITORING. For buildings or additions equipped with demand control ventilation, CO2 sensors and ventilation controls shall be specified and installed in accordance with the requirements of the California Energy Code, Section 120(c)(4).

SECTION 5.507 ENVIRONMENTAL COMFORT
5.507.4 ACOUSTICAL CONTROL. Employ building assemblies and components with Sound Transmission Class (STC) values determined in accordance with ASTM E 90 and ASTM E 413, or Outdoor-Indoor Sound Transmission Class (OITC) determined in accordance with ASTM E 1332, using either the prescriptive or performance method in Section 5.507.4.1 or 5.507.4.2.

Exception: Buildings with few or no occupants or where occupants are not likely to be affected by exterior noise, as determined by the enforcement authority, such as factories, stadiums, storage, enclosed parking structures and utility buildings.

Exception: [DSA-SS] For public schools and community colleges, the requirements of this section and all subsections apply only to new construction.

5.507.4.1 Exterior noise transmission, prescriptive method. Wall and roof-ceiling assemblies exposed to the noise source making up the building or addition envelope or altered envelope shall meet a composite STC rating of at least 50 or a composite OITC rating of no less than 40, with exterior windows of a minimum STC of 40 or OITC of 30 in the following locations:

- 1. Within the 65 CNEL noise contour of an airport.
Exception:
1. Lw or CNEL for military airports shall be determined by the facility Air Installation Compatible Land Use Zone (AICLUZ) plan.
2. Lw or CNEL for other airports and heliports for which a land use plan has not been developed shall be determined by the local general plan noise element.

2. Within the 65 CNEL or Lw noise contour of a freeway or expressway, railroad, industrial source or fixed-guideway source as determined by the Noise Element of the General Plan.

5.507.4.1.1 Noise exposure where noise contours are not readily available. Buildings exposed to a noise level of 65 dB Lw -1hr during any hour of operation shall have building, addition or alteration exterior wall and roof-ceiling assemblies exposed to the noise source meeting a composite STC rating of at least 45 (or OITC 35), with exterior windows of a minimum STC of 40 (or OITC 30).

5.507.4.2 Performance Method. For buildings located as defined in Section 5.507.4.1 or 5.507.4.1.1, wall and roof-ceiling assemblies exposed to the noise source making up the building or addition envelope or altered envelope shall be constructed to provide an interior noise environment attributable to exterior sources that does not exceed an hourly equivalent noise level (Leq-1hr) of 50 dBA in occupied areas during any hour of operation.

5.507.4.2.1 Site Features. Exterior features such as sound walls or earth berms may be utilized as appropriate to the building, addition or alteration project to mitigate sound migration to the interior.

5.507.4.2.2 Documentation of Compliance. An acoustical analysis documenting complying interior soundlevels shall be prepared by personnel approved by the architect or engineer of record.

5.507.4.3 Interior sound transmission. Wall and floor-ceiling assemblies separating tenant spaces and tenant spaces and public places shall have an STC of at least 40.
Note: Examples of assemblies and their various STC ratings may be found at the California Office of Noise Control: www.toolbox.org/PDF/CaseStudies/stc_ccc_ratings.pdf.

SECTION 5.508 OUTDOOR AIR QUALITY
5.508.1 Ozone depletion and greenhouse gas reductions. Installations of HVAC, refrigeration and fire suppression equipment shall comply with Sections 5.508.1.1 and 5.508.1.2.

5.508.1.1 Chlorofluorocarbons (CFCs). Install HVAC, refrigeration and fire suppression equipment that do not contain CFCs.

5.508.1.2 Halons. Install HVAC, refrigeration and fire suppression equipment that do not contain Halons.

5.508.2 Supermarket refrigerant leak reduction. New commercial refrigeration systems shall comply with the provisions of this section when installed in retail food stores 5,000 square feet or more conditioned area, and that utilize either refrigerated display cases, or walk-in coolers or freezers connected to remote compressor units or condensing units. The leak reduction measures apply to refrigeration systems containing high-global-warming potential (high-GWP) refrigerants with a GWP of 150 or greater. New refrigeration systems include both new facilities and the replacement of existing refrigeration systems in existing facilities.

Exception: Refrigeration systems containing low-global warming potential (low-GWP) refrigerant with a GWP value less than 150 are not subject to this section. Low-GWP refrigerants are nonozone-depleting refrigerants that include ammonia, carbon dioxide (CO2), and potentially other refrigerants.

Table with 2 columns: Y, N/A RESPON. PARTY. Row 1: X, G.C.

5.508.2.1 Refrigerant piping. Piping compliant with the California Mechanical Code shall be installed to be accessible for leak protection and repairs. Piping runs using threaded pipe, copper tubing with an outside diameter (OD) less than 1/4 inch, flared tubing connections and short radius elbows shall not be used in refrigerant systems except as noted below.

5.508.2.1.1 Threaded pipe. Threaded connections are permitted at the compressor rack.

5.508.2.1.2 Copper pipe. Copper tubing with an OD less than 1/4 inch may be used in systems with a refrigerant charge of 5 pounds or less.

5.508.2.1.2.1 Anchorage. One-fourth-inch OD tubing shall be securely clamped to a rigid base to keep vibration levels below 8 mils.

5.508.2.1.3 Flared tubing connections. Double-flared tubing connections may be used for pressure controls, valve pilot lines and oil.

Exception: Single-flared tubing connections may be used with a multilayer seal coated with industrial sealant suitable for use with refrigerants and tightened in accordance with manufacturer's recommendations.

5.508.2.1.4 Elbows. Short radius elbows are only permitted where space limitations prohibit use of long radius elbows.

5.508.2.2 Valves. Valves and fittings shall comply with the California Mechanical Code and as follows.

5.508.2.2.1 Pressure relief valves. For vessels containing high-GWP refrigerant, a rupture disc shall be installed between the outlet of the vessel and the inlet of the pressure relief valve.

5.508.2.2.1.1 Pressure detection. A pressure gauge, pressure transducer or other device shall be installed in the space between the rupture disc and the relief valve inlet to indicate a disc rupture or discharge of the relief valve.

5.508.2.2.2 Access valves. Only Schrader access valves with a brass or steel body are permitted for use.

5.508.2.2.2.1 Valve caps. For systems with a refrigerant charge of 5 pounds or more, valve caps shall be brass or steel and not plastic.

5.508.2.2.2.2 Seal caps. If designed for it, the cap shall have a neoprene O-ring in place.

5.508.2.2.2.2.1 Chain levers. Chain levers to fit or the stem are required for valves designed to have seal caps.

Exception: Valves with seal caps that are not removed from the valve during stem operation.

5.508.2.3 Refrigerated service cases. Refrigerated service cases holding food products containing vinegar and salt shall have evaporator coils of corrosion-resistant material, such as stainless steel, or be coated to prevent corrosion from these substances.

5.508.2.3.1 Coil coating. Consideration shall be given to the heat transfer efficiency of coil coating to maximize energy efficiency.

5.508.2.4 Refrigerant receivers. Refrigerant receivers with capacities greater than 200 pounds shall be fitted with a device that indicates the level of refrigerant in the receiver.

5.508.2.5 Pressure testing. The system shall be pressure tested during installation prior to evacuation and charging.

5.508.2.5.1 Minimum pressure. The system shall be charged with regulated dry nitrogen and appropriate tracer gas to bring system pressure up to 300 psig minimum.

5.508.2.5.2 Leaks. Check the system for leaks, repair any leaks, and retest for pressure using the same gauge.

5.508.2.5.3 Allowable pressure change. The system shall stand, unaltered, for 24 hours with no more than a +/- one pound pressure change from 300 psig, measured with the same gauge.

5.508.2.6 Evacuation. The system shall be evacuated after pressure testing and prior to charging.

5.508.2.6.1 First vacuum. Pull a system vacuum down to at least 1000 microns (+/- 50 microns), and hold for 30 minutes.

5.508.2.6.2 Second vacuum. Pull a second system vacuum to a minimum of 500 microns and hold for 30 minutes.

5.508.2.6.3 Third vacuum. Pull a third vacuum down to a minimum of 300 microns, and hold for 24 hours with a maximum drift of 100 microns over a 24-hour period.

CHAPTER 7 INSTALLER & SPECIAL INSPECTOR QUALIFICATIONS
702 QUALIFICATIONS
702.1 INSTALLER TRAINING. HVAC system installers shall be trained and certified in the proper installation of HVAC systems including ducts and equipment by a nationally or regionally recognized training or certification program. Uncertified persons may perform HVAC installations when under the direct supervision and responsibility of a person trained and certified to install HVAC systems or contractor licensed to install HVAC systems. Examples of acceptable HVAC training and certification programs include but are not limited to the following:

- 1. State certified apprenticeship programs.
2. Public utility training programs.
3. Training programs sponsored by trade, labor or statewide energy consulting or verification organizations.
4. Programs sponsored by manufacturing organizations.
5. Other programs acceptable to the enforcing agency.

702.2 SPECIAL INSPECTION [HCD]. When required by the enforcing agency, the owner or the responsible entity acting as the owner's agent shall employ one or more special inspectors to provide inspection or other duties necessary to substantiate compliance with this code. Special inspectors shall demonstrate competence to the satisfaction of the enforcing agency for the particular type of inspection or task to be performed. In addition to other certifications or qualifications acceptable to the enforcing agency, the following certifications or education may be considered by the enforcing agency when evaluating the qualifications of a special inspector:

- 1. Certification by a national or regional green building program or standard publisher.
2. Certification by a statewide energy consulting or verification organization, such as HERS raters, building performance contractors, and home energy auditors.
3. Successful completion of a third party apprentice training program in the appropriate trade.
4. Other programs acceptable to the enforcing agency.

Notes:
1. Special Inspectors shall be independent entities with no financial interest in the materials or the project they are inspecting for compliance with this code.
2. HERS raters are special inspectors certified by the California Energy Commission (CEC) to rate homes in California according to the Home Energy Rating System (HERS).

[BSC-CG] When required by the enforcing agency, the owner or the responsible entity acting as the owner's agent shall employ one or more special inspectors to provide inspection or other duties necessary to substantiate compliance with this code. Special inspectors shall demonstrate competence to the satisfaction of the enforcing agency for the particular type of inspection or task to be performed. In addition, the special inspector shall have a certification from a recognized state, national or international association, as determined by the local agency. The area of certification shall be closely related to the primary job function, as determined by the local agency.

Note: Special inspectors shall be independent entities with no financial interest in the materials or the project they are inspecting for compliance with this code.

703 VERIFICATIONS
703.1 DOCUMENTATION. Documentation used to show compliance with this code shall include but is not limited to, construction documents, plans, specifications, builder or installer certification, inspection reports, or other methods acceptable to the enforcing agency which demonstrate substantial performance. When specific documentation or special inspection is necessary to verify compliance, that method of compliance will be specified in the appropriate section or identified applicable checklist.



PROJECT

TENANT IMPROVEMENTS FOR ECONOMIC DEVELOPMENT AND CHILD SUPPORT SERVICES

2420 6TH STREET EUREKA, CA



CHAPTER 7 INSTALLER & SPECIAL INSPECTOR QUALIFICATIONS

702 QUALIFICATIONS
702.1 INSTALLER TRAINING. HVAC system installers shall be trained and certified in the proper installation of HVAC systems including ducts and equipment by a nationally or regionally recognized training or certification program. Uncertified persons may perform HVAC installations when under the direct supervision and responsibility of a person trained and certified to install HVAC systems or contractor licensed to install HVAC systems. Examples of acceptable HVAC training and certification programs include but are not limited to the following:

- 1. State certified apprenticeship programs.
2. Public utility training programs.
3. Training programs sponsored by trade, labor or statewide energy consulting or verification organizations.
4. Programs sponsored by manufacturing organizations.
5. Other programs acceptable to the enforcing agency.

702.2 SPECIAL INSPECTION [HCD]. When required by the enforcing agency, the owner or the responsible entity acting as the owner's agent shall employ one or more special inspectors to provide inspection or other duties necessary to substantiate compliance with this code. Special inspectors shall demonstrate competence to the satisfaction of the enforcing agency for the particular type of inspection or task to be performed. In addition to other certifications or qualifications acceptable to the enforcing agency, the following certifications or education may be considered by the enforcing agency when evaluating the qualifications of a special inspector:

- 1. Certification by a national or regional green building program or standard publisher.
2. Certification by a statewide energy consulting or verification organization, such as HERS raters, building performance contractors, and home energy auditors.
3. Successful completion of a third party apprentice training program in the appropriate trade.
4. Other programs acceptable to the enforcing agency.

Notes:
1. Special Inspectors shall be independent entities with no financial interest in the materials or the project they are inspecting for compliance with this code.
2. HERS raters are special inspectors certified by the California Energy Commission (CEC) to rate homes in California according to the Home Energy Rating System (HERS).

[BSC-CG] When required by the enforcing agency, the owner or the responsible entity acting as the owner's agent shall employ one or more special inspectors to provide inspection or other duties necessary to substantiate compliance with this code. Special inspectors shall demonstrate competence to the satisfaction of the enforcing agency for the particular type of inspection or task to be performed. In addition, the special inspector shall have a certification from a recognized state, national or international association, as determined by the local agency. The area of certification shall be closely related to the primary job function, as determined by the local agency.

Note: Special inspectors shall be independent entities with no financial interest in the materials or the project they are inspecting for compliance with this code.

703 VERIFICATIONS
703.1 DOCUMENTATION. Documentation used to show compliance with this code shall include but is not limited to, construction documents, plans, specifications, builder or installer certification, inspection reports, or other methods acceptable to the enforcing agency which demonstrate substantial performance. When specific documentation or special inspection is necessary to verify compliance, that method of compliance will be specified in the appropriate section or identified applicable checklist.

Table with 3 columns: No., Description, Date. Row 1: 1. PLAN CHECK COMMENTS, 12/12/22

CALGREN CHECKLIST

Table with 2 columns: Project number, Date, Drawn by, Checked by. Values: 2108, 5/8/22, Author, Checker

Indoor Lighting Mandatory Measures:

110.9 LIGHTING CONTROLS AND COMPONENTS
ALL LIGHTING CONTROL DEVICES AND SYSTEMS, AND ALL LIGHT SOURCES SHALL MEET THE APPLICABLE REQUIREMENTS OF 110.9.
110.12(c) DEMAND RESPONSIVE LIGHTING CONTROLS
LIGHTING CONTROLS IN NONRESIDENTIAL BUILDINGS >10,000 FT2 SHALL BE CAPABLE OF AUTOMATICALLY REDUCING LIGHTING POWER IN RESPONSE TO A DEMAND RESPONSE SIGNAL. GENERAL LIGHTING SHALL BE REDUCED PER TABLE 130.1-A. CONTROLS SHALL DEMONSTRATE A LIGHTING POWER REDUCTION OF AT LEAST 15% BELOW THE TOTAL INSTALLED LIGHTING POWER IN CONTROLLED SPACES.
130.0 GENERAL LUMINAIRE REQUIREMENTS
ALL LUMINAIRES SHALL BE FACTORY-LABELLED PER 130.0(c). ENERGY MANAGEMENT CONTROL SYSTEMS (EMCS) SHALL MEET REQUIREMENTS OF 130.0(e).
130.1(a) MANUAL AREA CONTROLS
EACH ROOM OR AREA WITH FLOOR-TO-CEILING WALLS IN THIS BUILDING SHALL HAVE LIGHTING CONTROLS THAT ALLOW LIGHTING TO BE MANUALLY TURNED ON AND OFF MANUALLY CONTROLLED SHALL:
1. BE READILY ACCESSIBLE
2. BE LOCATED IN THE SAME ENCLOSED AREA WITH THE LIGHTING IT CONTROLS.
3. PROVIDE SEPARATE CONTROL OF GENERAL, FLOOR, WALL, WINDOW CASE DISPLAY, ORNAMENTAL AND SPECIAL EFFECTS LIGHTING SO EACH TYPE CAN BE TURNED ON AND OFF SEPARATELY WITHOUT AFFECTING OTHER LIGHTING OR EQUIPMENT.
130.1(b) MULTILEVEL LIGHTING CONTROLS
GENERAL LIGHTING IN ALL ROOMS AND AREAS 100 FT2 OR GREATER AND WITH MORE THAN 0.5 WATTS PER FT2 OF LIGHTING LOAD SHALL HAVE MULTILEVEL CONTROLS THAT ALLOW LIGHT LEVELS TO BE ADJUSTED UP AND DOWN. CONTROLS SHALL PROVIDE NUMBER OF CONTROL STEPS AND UNIFORM LIGHT LEVELS PER TABLE 130.1-A.
130.1(c) SHUTOFF CONTROLS
ALL INSTALLED INDOOR LIGHTING SHALL BE EQUIPPED WITH CONTROLS TO AUTOMATICALLY REDUCE LIGHTING POWER WHEN SPACE IS TYPICALLY UNOCCUPIED.
130.1(c)(1) CONTROL REQUIREMENTS
ALL INSTALLED INDOOR LIGHTING SHALL HAVE ALL OF THE FOLLOWING:
A. CONTROL(S) CAPABLE OF AUTOMATICALLY SHUTTING OFF ALL LIGHTING IN THE SPACE WHEN TYPICALLY UNOCCUPIED (OCCUPANT SENSING CONTROL, AUTOMATIC TIME-SWITCH CONTROL, OR OTHER)
B. SEPARATE CONTROLS FOR LIGHTING ON EACH FLOOR (OTHER THAN STAIRWELLS)
C. SEPARATE CONTROLS FOR A SPACE ENCLOSED BY CEILING HEIGHT PARTITIONS NOT EXCEEDING 5,000 FT2
D. SEPARATE CONTROLS FOR GENERAL, DISPLAY, ORNAMENTAL, AND DISPLAY CASE LIGHTING
E. AUTOMATIC TIME-SWITCH CONTROLS MAY INCLUDE MANUAL-ON MODE
130.1(c)(2) COUNTDOWN TIMER SWITCHES
COUNTDOWN TIMER SWITCHES ONLY ALLOWED TO MEET SHUT-OFF REQUIREMENTS IN CLOSETS <70 FT2 AND SERVER AISLES IN SERVER ROOMS. MAXIMUM TIMER

Indoor Lighting Mandatory Measures:

130.1(c)(6) PARTIAL OR FULL-OFF OCCUPANT SENSORS
PROVIDE PARTIAL OR FULL-OFF OCCUPANT SENSORS, IN ADDITION TO SHUTOFF CONTROLS PER 130.1(c)(1) AND 130.1(c)(2), IN THE FOLLOWING SPACES:
• ASLE WAYS AND OPEN AREAS IN WAREHOUSES
• LIBRARY BOOK STACK AISLES
• CORRIDORS AND STAIRWELLS
130.1(d) AUTOMATIC DAYLIGHTING CONTROLS
ALL GENERAL LIGHTING IN THE FOLLOWING ZONES SHALL HAVE CONTROLS THAT AUTOMATICALLY ADJUST THE INSTALLED LIGHTING POWER UP AND DOWN TO KEEP TOTAL LIGHT LEVEL STABLE AS INCOMING DAYLIGHT CHANGES:
• PRIMARY SIDELIT DAYLIT ZONES
• SKYLIT DAYLIT ZONES
• COMBINED PRIMARY AND SECONDARY SIDELIT DAYLIT ZONES IN PARKING GARAGES
ALL DAYLIT ZONES MUST BE SHOWN ON PLANS.
NOTE: PARKING AREAS ON THE ROOF OF A PARKING STRUCTURE ARE NOT SKYLIT DAYLIT AREAS.
IN ADDITION, AUTOMATIC DAYLIGHTING CONTROLS SHALL PROVIDE SEPARATE CONTROL FOR LUMINAIRES IN EACH TYPE OF DAYLIT ZONE. LUMINAIRES THAT FALL IN BOTH SKYLIT AND SIDELIT DAYLIT ZONE SHALL BE CONTROLLED AS PART OF THE SKYLIT ZONE.
130.1(d)(3) THE AUTOMATIC DAYLIGHTING CONTROLS SHALL ACHIEVE ALL OF THE FOLLOWING:
A. ADJUST LIGHTING VIA CONTINUOUS DIMMING OR THE NUMBER OF CONTROL STEPS PROVIDED BY THE MULTILEVEL CONTROLS (FOR SPACES REQUIRED TO INSTALL MULTILEVEL CONTROLS UNDER SECTION 130.1(b)).
B. FOR EACH SPACE, ENSURE COMBINED ILLUMINANCE FROM CONTROLLED LIGHTING AND DAYLIGHT IS NOT LESS THAN ILLUMINANCE FROM CONTROLLED LIGHTING WHEN NO DAYLIGHT IS AVAILABLE
C. ENSURE THAT THE GENERAL LIGHTING POWER IN A DAYLIT ZONE SHALL BE REDUCED BY AT LEAST 65% WHEN DAYLIGHT ILLUMINANCE IN THAT ZONE IS GREATER THAN 150% OF DESIGN ILLUMINANCE RECEIVED FROM THE GENERAL LIGHTING SYSTEM AT FULL POWER (NOT APPLICABLE TO PARKING GARAGES).
D. (FOR PARKING GARAGES ONLY) ENSURE THAT WHEN ILLUMINANCE LEVELS MEASURED AT THE FARTHEST EDGE OF THE SECONDARY SIDELIT ZONE AWAY FROM GLAZING OR OPENING ARE GREATER THAN 150% OF THE ILLUMINANCE PROVIDED BY THE CONTROLLED LIGHTING WHEN NO DAYLIGHT IS AVAILABLE, THE CONTROLLED LIGHTING POWER CONSUMPTION IS ZERO.
130.1(d)(4) WHEN PHOTOSENSORS ARE LOCATED WITHIN THE DAYLIT ZONE, AT LEAST ONE PHOTOSENSOR SHALL BE LOCATED SO THAT IT IS NOT READILY ACCESSIBLE TO UNAUTHORIZED PERSONNEL.
130.1(d)(5) THE LOCATION WHERE CALIBRATION ADJUSTMENTS ARE MADE TO AUTOMATIC DAYLIGHTING CONTROLS SHALL BE READILY ACCESSIBLE TO AUTHORIZED PERSONNEL BUT MAY BE INSIDE A LOCKED CASE OR UNDER A COVER THAT REQUIRES A TOOL FOR ACCESS.

Indoor Lighting Mandatory Measures:

130.1(f) CONTROL INTERACTIONS
EACH LIGHTING CONTROL INSTALLED TO MEET 130.1 REQUIREMENTS SHALL INCORPORATE THE FUNCTIONS OF OTHER LIGHTING CONTROLS REQUIRED BY THIS SECTION.
1. FOR GENERAL LIGHTING, MANUAL AREA CONTROL SHALL PERMIT THE LEVEL OF LIGHT PROVIDED WHILE LIGHTING IS ON TO BE SET OR ADJUSTED BY CONTROLS SPECIFIED IN 130.1(b), (c), (d) and (e).
2. MANUAL AREA CONTROL SHALL PERMIT SHUTOFF CONTROL TO TURN THE LIGHTING DOWN OR OFF.
3. MULTILEVEL CONTROL SHALL PERMIT THE AUTOMATIC DAYLIGHTING CONTROL TO ADJUST ELECTRIC LIGHTING IN RESPONSE TO DAYLIGHT.
4. MULTILEVEL CONTROL SHALL PERMIT THE DEMAND RESPONSIVE (DR) CONTROL TO ADJUST LIGHTING DURING A DR EVENT THEN RETURN IT TO THE LEVEL SET BY THE CONTROL AFTER THE EVENT.
5. SHUTOFF CONTROL SHALL PERMIT THE MANUAL AREA CONTROL TO TURN THE LIGHTING ON.
6. AUTOMATIC DAYLIGHTING CONTROL SHALL PERMIT MULTILEVEL LIGHTING CONTROL TO ADJUST THE LIGHTING LEVEL.
7. FOR LIGHTING CONTROLLED BY MULTILEVEL LIGHTING CONTROLS AND OCCUPANT SENSING CONTROLS THAT PROVIDE AUTOMATIC ON/FUNCTION, CONTROLS SHALL PROVIDE A PARTIAL-ON FUNCTION THAT IS CAPABLE OF AUTOMATICALLY ACTIVATING BETWEEN 50-70% OF CONTROLLED LIGHTING POWER.

STATE OF CALIFORNIA
Indoor Lighting
CERTIFICATE OF COMPLIANCE
Project Name: County of Humboldt Tenant Improvements 2022 6th Street, Eureka
Project Address: 2022-09-16T16:18:43-04:00

Table with 6 columns: O1, O2, O3, O4, O5, O6. Rows include Area Description, Complete Building or Area Category Primary Function Area, Allowed Density (W/H^2), Area (ft^2), Allowed Wattage (Watts), Additional Allowance / Adjustment Area Category, PAF.

J. ADDITIONAL ALLOWANCE: AREA CATEGORY METHOD QUALIFYING LIGHTING SYSTEM
This section does not apply to this project.

K. TAILORED METHOD GENERAL LIGHTING POWER ALLOWANCE
This section does not apply to this project.

L. ADDITIONAL LIGHTING ALLOWANCE: TAILORED WALL DISPLAY
This section does not apply to this project.

M. ADDITIONAL LIGHTING ALLOWANCE: TAILORED FLOOR AND TASK LIGHTING
This section does not apply to this project.

N. ADDITIONAL LIGHTING ALLOWANCE: TAILORED ORNAMENTAL/SPECIAL EFFECTS
This section does not apply to this project.

O. ADDITIONAL LIGHTING ALLOWANCE: TAILORED VERY VALUABLE MERCHANDISE
This section does not apply to this project.

P. POWER ADJUSTMENT: LIGHTING CONTROL CREDIT (POWER ADJUSTMENT FACTOR (PAF))
This section does not apply to this project.

Registration Number: Generated Date/Time: Documentation Software: Energy Code Ace

STATE OF CALIFORNIA
Indoor Lighting
CERTIFICATE OF COMPLIANCE
Project Name: County of Humboldt Tenant Improvements 2022 6th Street, Eureka
Project Address: 2022-09-16T16:18:43-04:00

Q. RATED POWER REDUCTION COMPLIANCE FOR ALTERATIONS
This section does not apply to this project.

R. 80% LIGHTING POWER FOR ALL ALTERATIONS - CONTROLS EXCEPTIONS
This section does not apply to this project.

S. DAYLIGHT DESIGN POWER ADJUSTMENT FACTOR (PAF)
This section does not apply to this project.

T. DECLARATION OF REQUIRED CERTIFICATES OF INSTALLATION
Selections have been made based on information provided in this document. If any selection have been changed by permit applicant, an explanation should be included in Table E. Additional Remarks. These documents must be provided to the building inspector during construction and can be found online at https://www.energy.ca.gov/title24/2019standards/2019_compliance_documents/Nonresidential_Documents/NRC/

Form/Title
NRCI-LTI-01-E - Must be submitted for all buildings
NRCI-LTI-02-E - Must be submitted for a lighting control system, or for an Energy Management Control System (EMCS), to be recognized for compliance.

U. DECLARATION OF REQUIRED CERTIFICATES OF ACCEPTANCE
Selections have been made based on information provided in this document. If any selection have been changed by the permit applicant, an explanation should be included in Table E. Additional Remarks. These documents must be provided to the building inspector during construction and any with "A" in the form name must be completed through an Acceptance Test Technician Certification Provider (ATTCP). For more information visit: http://www.energy.ca.gov/title24/attcp/providers.html

Form/Title
NRCI-LTI-02-A - Must be submitted for occupancy sensors and automatic time switch controls.
NRCI-LTI-03-A - Must be submitted for automatic daylight controls.

STATE OF CALIFORNIA
Indoor Lighting
CERTIFICATE OF COMPLIANCE
Project Name: County of Humboldt Tenant Improvements 2022 6th Street, Eureka
Project Address: 2022-09-16T16:18:43-04:00

DOCUMENTATION AUTHOR'S DECLARATION STATEMENT
I certify that this Certificate of Compliance documentation is accurate and complete.

Documentation Author Name: DONALD ALAMEIDA
Company: Alameida Architecture
Address: 555 S. Main St. Suite 2
City/State/Zip: Sebastopol, CA 95472
Signature Date: 5/10/22
CEA/HERS Certification Identification (if applicable):
Phone: 707 824-1219

RESPONSIBLE PERSON'S DECLARATION STATEMENT
I certify the following under penalty of perjury, under the laws of the State of California:
1. The information provided on this Certificate of Compliance is true and correct.
2. I am eligible under Division 3 of the Business and Professions Code to accept responsibility for the building design or system design identified on this Certificate of Compliance (responsible design).
3. The energy features and performance specifications, materials, components, and manufacturer cut sheets for the building design or system design identified on this Certificate of Compliance conform to the requirements of Title 24, Part 1 and Part 6 of the California Code of Regulations.
4. The building design features or system design features identified on this Certificate of Compliance are consistent with the information provided on other applicable compliance documents, worksheets, calculations, plans and specifications submitted to the enforcement agency for approval with this building permit application.
5. I will ensure that a completed signed copy of this Certificate of Compliance shall be made available with the building permit(s) issued for the building, and made available to the enforcement agency for all applicable inspections. I understand that a completed signed copy of this Certificate of Compliance is required to be included with the documentation the building provides to the building owner at occupancy.

Responsible Designer Name: DONALD ALAMEIDA
Company: Alameida Architecture
Address: 555 S. Main St. Suite 2
City/State/Zip: Sebastopol, CA 95472
Signature Date: 5/10/22
Phone: 707 824-1219

Registration Number: Generated Date/Time: Documentation Software: Energy Code Ace
CA Building Energy Efficiency Standards - 2019 Nonresidential Compliance
Report Version: 2019.1.003
Schema Version: rev 20200601
Compliance ID: 67997
Report Generated: 2022-09-16 13:18:46

STATE OF CALIFORNIA
Indoor Lighting
CERTIFICATE OF COMPLIANCE
Project Name: County of Humboldt Tenant Improvements 2022 6th Street, Eureka
Project Address: 2022-09-16T16:18:43-04:00

Table with 4 columns: O1, O2, O3, O4. Rows include Project Location (city), Climate Zone, Occupancy Types Within Project (select all that apply).

B. PROJECT SCOPE
This table includes any lighting systems that are within the scope of the permit application and are demonstrating compliance using the prescriptive path outlined in §140.6 or §141.0b(2) for alterations.

Table with 5 columns: Scope of Work, Calculation Method, Area (ft^2), Calculation Method, Area (ft^2). Rows include My Project Consists of (check all that apply), New Lighting System, New Lighting System - Parking Garage, Altered Lighting System.

STATE OF CALIFORNIA
Indoor Lighting
CERTIFICATE OF COMPLIANCE
Project Name: County of Humboldt Tenant Improvements 2022 6th Street, Eureka
Project Address: 2022-09-16T16:18:43-04:00

C. COMPLIANCE RESULTS
If any cell on this table says "DOES NOT COMPLY" or "COMPLIES with Exceptional Conditions" refer to Table D, for guidance.

Table with 10 columns: O1, O2, O3, O4, O5, O6, O7, O8, O9, O10. Rows include Lighting in conditioned and unconditioned spaces must not be combined for compliance per §140.6(b)(1), Adjusted Lighting Power per §140.6(a) (Watts), Compliance Results.

D. EXCEPTIONAL CONDITIONS
This table is auto-filled with uneditable comments because of selections made or data entered in tables throughout the form. Track Lighting has been included in this project, details are provided in Table G.

E. ADDITIONAL REMARKS
This table includes remarks made by the permit applicant to the Authority Having Jurisdiction.

F. INDOOR LIGHTING FIXTURE SCHEDULE
This table includes all permanent designed lighting and all portable lighting in offices.

Table with 10 columns: O1, O2, O3, O4, O5, O6, O7, O8, O9, O10. Rows include Name or Item Tag, Complete Luminaire Description, Modular (Track) Fixture, Small Aperture & Color Change, Watts per luminaire^2, How is Wattage determined, Total Number of Luminaires, Excluded per §140.6(a)(3), Design Watts, Field Inspector Pass/Fail.

STATE OF CALIFORNIA
Indoor Lighting
CERTIFICATE OF COMPLIANCE
Project Name: County of Humboldt Tenant Improvements 2022 6th Street, Eureka
Project Address: 2022-09-16T16:18:43-04:00

Table with 10 columns: A, B, D, F, H, L, K, E. Rows include LED RETROFIT FOR (E) PARBOLIC LIGHTS, LED RETROFIT/RELOCATE EXISTING PARBOLIC, S14 LED PENDENT, LED RECESSED CAN LIGHT, 2x2 DIM LED, LED RING PENDENT, TRACK LIGHT FIXTURE SILO DYNAMIC, EXISTING FUTURE TO REMAIN.

*FOOTNOTE: Design Watts for small aperture and color changing luminaires which qualify per §140.6(a)(8) is adjusted to be 75% of their rated wattage. Table F automatically makes this adjustment, the permit applicant should enter full rated wattage in column 05.
*Authority Having Jurisdiction may ask for Luminaire cut sheets to confirm wattage used for compliance per §130.0(c). Wattage used must be the maximum rated for the luminaire, not the lamp.

G. MODULAR LIGHTING SYSTEMS
This table calculates wattage for modular lighting systems/track lighting fixtures indicated on Table F and transfers wattage to Table F.

Table with 4 columns: O1, O2, O3, O4. Rows include Name or Item Tag, Complete Track Description, Calculation Method per §130.0(c)(6), Track Wattage.

STATE OF CALIFORNIA
Indoor Lighting
CERTIFICATE OF COMPLIANCE
Project Name: County of Humboldt Tenant Improvements 2022 6th Street, Eureka
Project Address: 2022-09-16T16:18:43-04:00

Table with 2 columns: Number of luminaires in system, Rated Watts per luminaire. Rows include Total Watts, Linear ft of track or busway, Default W/L/F, Total Watts.

*FOOTNOTE: For power-over-Ethernet lighting systems, power provided to installed non-lighting devices may be subtracted from the total power rating of the power-over-Ethernet system.

H. INDOOR LIGHTING CONTROLS (Not including PAFs)
This table includes lighting controls for conditioned and unconditioned spaces. When a control having a "I" is shown, the notes section of this table provides more detail on how compliance is achieved. The lighting controls section of the Compliance Summary Table on the first page will show "DOES NOT COMPLY" if the notes are left blank.

Table with 3 columns: O1, O2, O3. Rows include Mandatory Demand Response §110.12(c), Shut-off controls §130.1(c), Field Inspector Pass/Fail.

Table with 12 columns: O4, O5, O6, O7, O8, O9, O10, O11, O12. Rows include Area Description, Complete Building or Area Category Primary Function Area, Area Controls §130.1(a), Multi-Level Controls §130.1(b), Shut-Off Controls §130.1(c), Primary/Sky lit Daylighting §130.1(d), Secondary Daylighting §130.6(d), Interlocked Systems §130.6(a)(1), Field Inspector Pass/Fail.

*NOTES: Controls with a "I" require a note in the space below explaining how compliance is achieved.
EX: Conference 1: Primary/SkyLight Daylighting. Exempt because less than 120 watts of general lighting; EXCEPTION 1 to §130.1(d)(2)

Registration Number: Generated Date/Time: Documentation Software: Energy Code Ace
CA Building Energy Efficiency Standards - 2019 Nonresidential Compliance
Report Version: 2019.1.003
Schema Version: rev 20200601
Compliance ID: 67997
Report Generated: 2022-09-16 13:18:46

PROJECT MANAGEMENT

ALAMEIDA ARCHITECTURE

CONSTRUCTION MANAGEMENT

555 S. MAIN STREET, SUITE 2
SEBASTOPOL, CA 95472
(707) 824-1219
WWW.ALAMEIDA.COM



PROJECT

TENANT IMPROVEMENTS FOR ECONOMIC DEVELOPMENT AND CHILD SUPPORT SERVICES

2420 6TH STREET
EUREKA, CA



Table with 3 columns: No., Description, Date. Row 1: PLAN CHECK COMMENTS, 12/1/22

Table with 3 columns: No., Description, Date. Multiple empty rows for plan check comments.

TITLE 24 INDOOR LIGHTING

Table with 2 columns: Project number, Date, Drawn by, Checked by. Values: 2108, 5/8/22, Author, Checker

T24-1

Scale

