

McKay Community Forest (existing)
 Phase 2 Property (proposed)



0 550 1,100
 Feet

Imagery: USDA-NAIP (2018)
 Date Printed: June 9, 2020

| | |
|--|--------------|
| <h2>McKay Community Forest</h2> | |
| Proposed Phase 2 Property Acquisition | Map 1 |

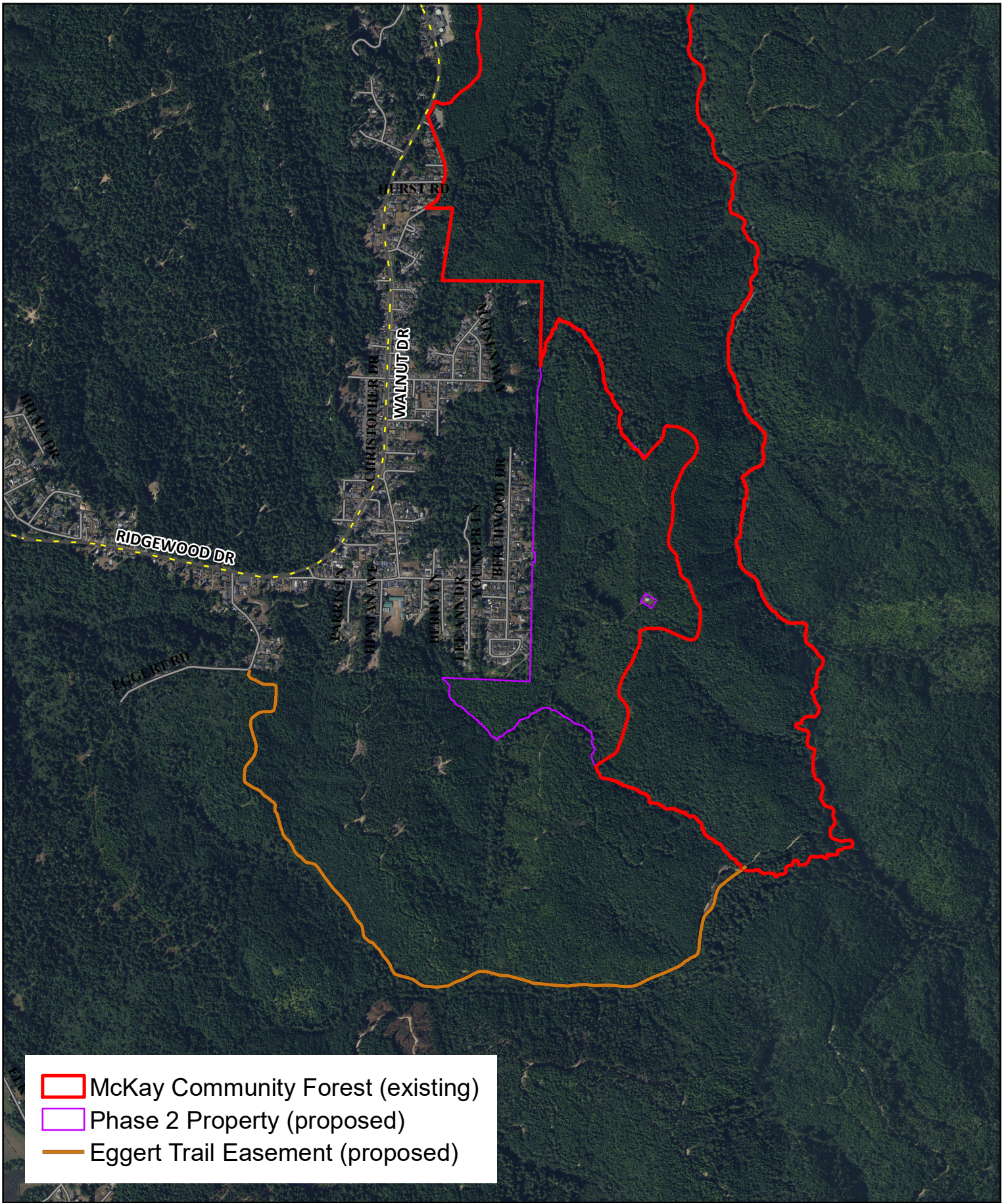

0 875 1,750
 Feet

Imagery: USDA-NAIP (2018)
 Date Printed: June 9, 2020

McKay Community Forest

| | |
|--|--------------|
| Proposed Phase 2 Property Acquisition and Eggert Connector Trail Easement | Map 2 |
|--|--------------|

- ▭ McKay Community Forest (existing)
- ▭ Phase 2 Property (proposed)
- Eggert Trail Easement (proposed)

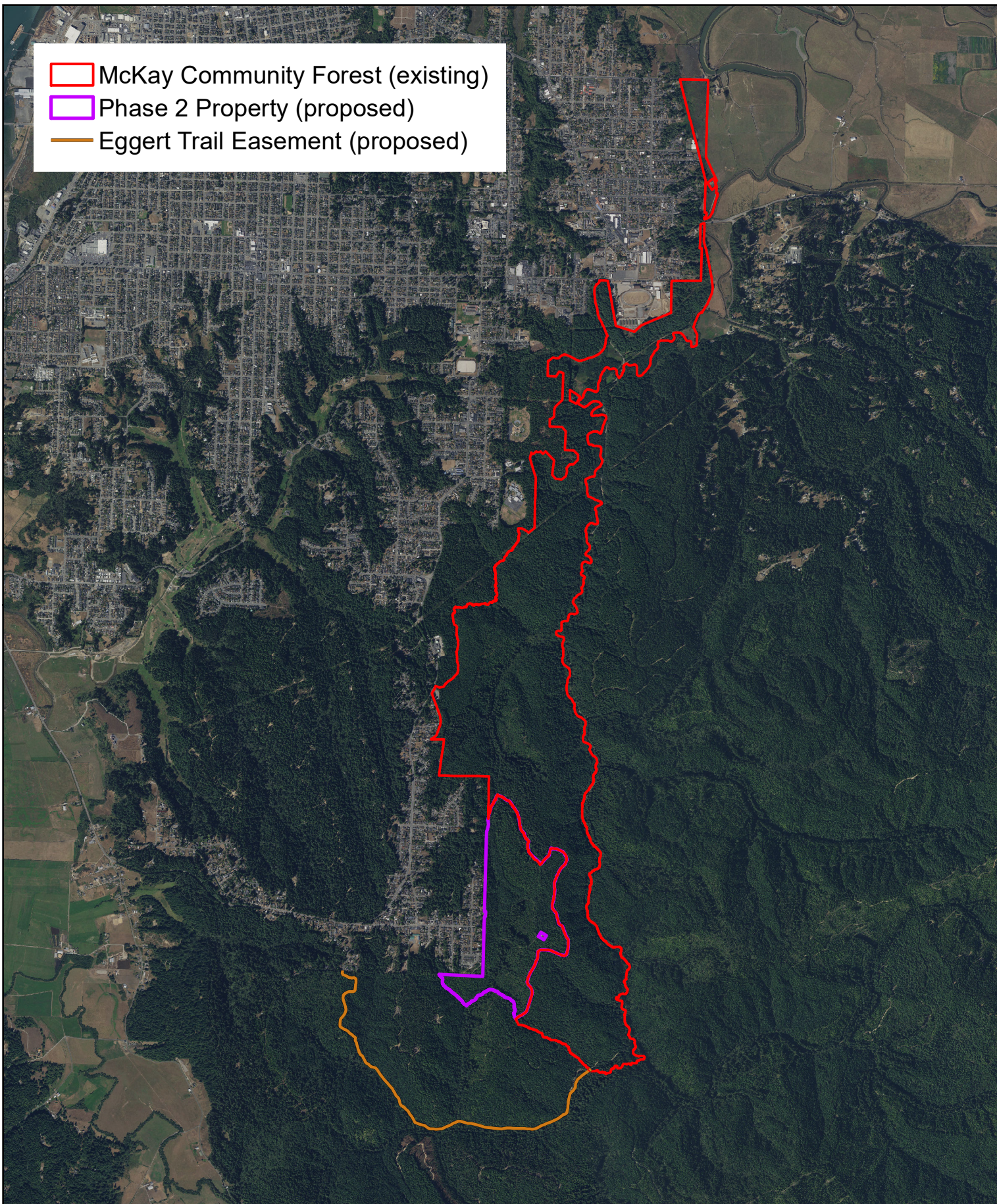

0 1,750 3,500
 Feet

Imagery: USDA-NAIP (2018)
 Date Printed: June 9, 2020



McKay Community Forest

**Proposed Phase 2 Property Acquisition and
 Eggert Trail Easement**

Map 3

Assessor's Map Bk. 303, Pg. 01
County of Humboldt, CA.

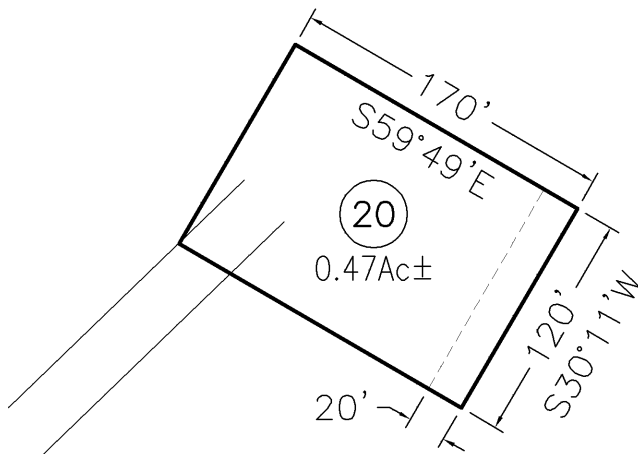
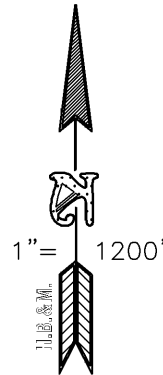

DETAIL "A"
SCALE: 1" = 100'

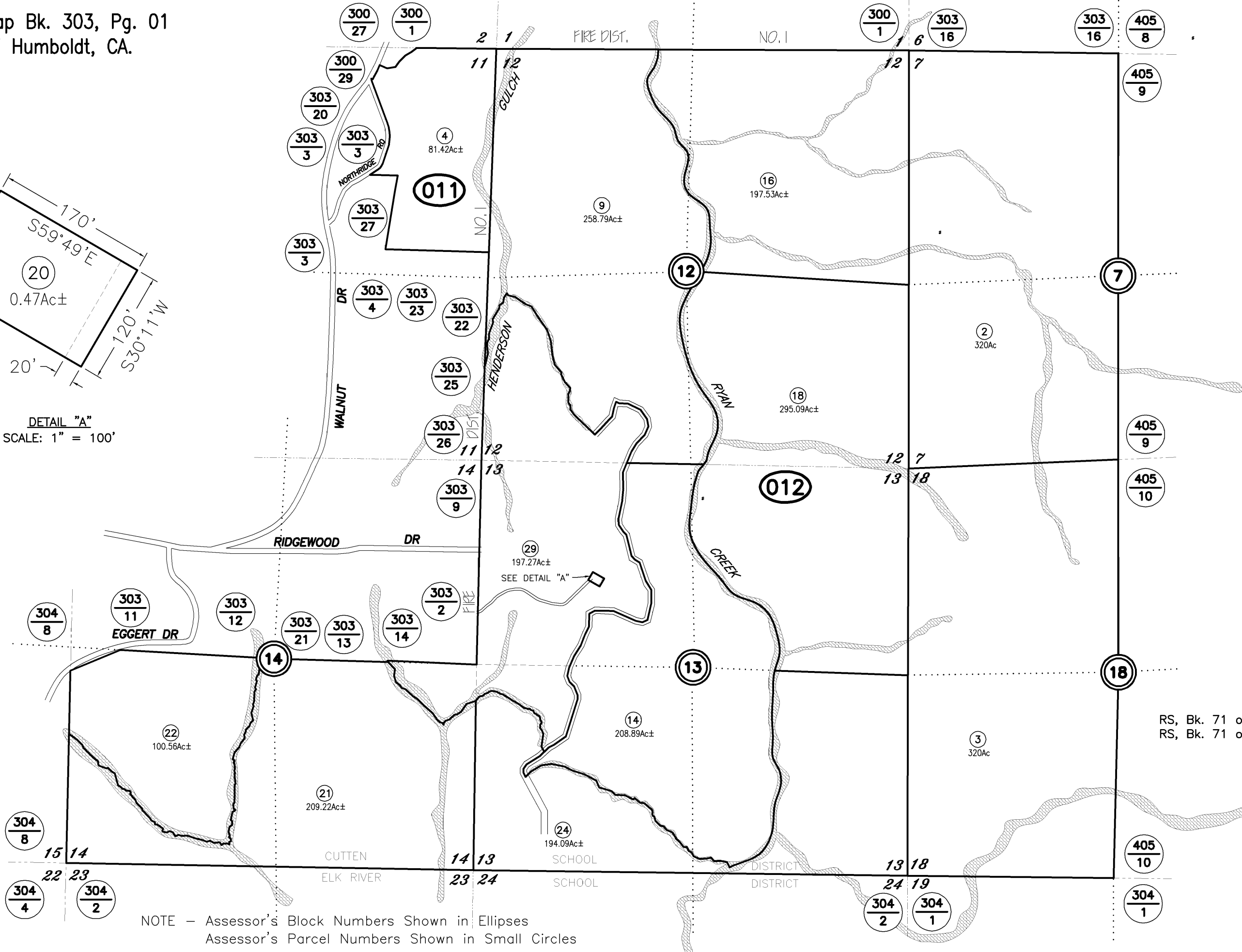

RS, Bk. 71 of Surveys, Pg. 44-50
RS, Bk. 71 of Surveys, Pg. 126

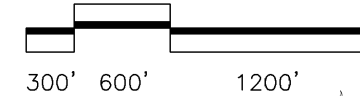

RD
June 15, 2018
RUSSELL DUTRA

NOTE - Assessor's Block Numbers Shown in Ellipses
Assessor's Parcel Numbers Shown in Small Circles

ASSESSOR'S PARCEL MAP

1. THIS MAP WAS PREPARED FOR ASSESSMENT PURPOSES ONLY. NO LIABILITY IS ASSUMED FOR THE ACCURACY OF THE DATA SHOWN.
2. THE ACCURACY OF THE DATA SHOWN.
3. ASSESSOR'S PARCELS MAY NOT COMPLY WITH LOCAL LOT-SPLIT OR BUILDING SITE ORDINANCES.

Ryan Conservation Tract on Green Diamond Lands (Phase 3 Conservation Easement)

