

AGREEMENT

This is an AGREEMENT made and entered into this 17th day
of January, 20 23, by and between the County of Humboldt, a
political subdivision of the State of California (hereinafter referred to as COUNTY)
and 6 Rivers Construction, Inc.,
a corporation organized and existing under the laws of the State of California,
hereinafter referred to as "CONTRACTOR".

Section 1 - SCOPE OF WORK

Contractor shall furnish all Labor, Tools and Materials and perform all the work for the:

**ROAD MAINTENANCE ON BALD HILLS ROAD (F4R300) PM 16.05-19.04
CONTRACT NO.: 321623**

in accordance with the contract documents referred to in Section 3 of this Agreement.

Section 2 - CONTRACT PRICE

County shall pay, and Contractor shall accept Contractor's Bid Prices, as shown on EXHIBIT "A" attached hereto and made a part hereof, as full compensation for furnishing all materials and for doing all the work contemplated and embraced in this Agreement; also for all loss or damage, arising out of the work aforesaid, or from the actions of the elements, or from any unforeseen difficulties or obstructions which may arise or be encountered in the prosecution of the work until its acceptance by County, and for all risks of every description connected with the work; also for all expenses incurred by or in consequence of the suspension or discontinuance of the work and for well and faithfully completing the work, and the whole thereof, in the manner and according to the Plans and Specifications, and the requirements of the Engineer.

Section 3 - CONTRACT DOCUMENTS

The complete contract between the parties hereto shall consist of the following, hereinafter referred to as the CONTRACT DOCUMENTS:

- Notice to Bidders
- Plans and Drawings
- Bid Form
- Bidder's Bond
- Performance Bond
- Payment Bond
- This Agreement
- Special Provisions

And, as published by the Department of Transportation, State of California, except as modified by the Special Provisions:

- Standard Plans - dated 2018
- Revised Standard Plans – dated 04-17-2020
- Standard Specifications - dated 2018
- Revised Standard Specifications Dated 04-17-2020
- Equipment Rental Rates in effect at the time the work is performed

And, as published by the California Department of Industrial Relations, and the California Business, Transportation and Housing Agency:

- General Prevailing Wage Rates
- Labor and Surcharge Rates

And any addenda to any of the above documents, all of which are on file in the office of the Director of Public Works of the County of Humboldt. Each of said CONTRACT DOCUMENTS is incorporated and made a part of this Agreement by the reference contained in this Section.

All rights and obligations of the County and the Contractor are fully set forth and described in the Contract Documents. All of the above named documents are intended to be complimentary, so that any work called for in one, and mentioned in the other is to be performed and executed the same as if mentioned in all said documents.

Section 4 - BEGINNING OF WORK

Following receipt and full execution and approval of the Contract Documents, and posting of the requisite Bonds as called for therein, the COUNTY will issue a "Notice to Proceed". Under no circumstances shall the CONTRACTOR enter upon the site of work until receipt of the "Notice to Proceed", or unless so authorized in writing by the COUNTY.

Section 5 - TIME OF COMPLETION

The work called for in this Agreement shall be commenced within forty-fifth (45) days of receipt of Notice to Proceed by COUNTY and shall be fully completed within a period of 30 working days beginning on the forty-fifth calendar day after the date of said approval of contract.

Section 6 - PREVAILING WAGE

Copies of the prevailing wage rates of per diem wages are on file in the Humboldt County Public Works office at 1106 Second Street, Eureka, California and are available to any interested person on request.

Section 7 - WORKERS' COMPENSATION

By my signature hereunder, as CONTRACTOR, I certify that I am aware of the provisions of Section 3700 of the Labor Code which requires every employer to be insured against liability for Workers' Compensation or to undertake self insurance in accordance with the provisions of that code, and I will comply with such provisions before commencing the performance of the work of this contract.

Section 8 - COMPLIANCE WITH LAWS

The Contractor agrees to comply with all local, state, and federal laws and regulations, including but not limited to the Americans With Disabilities Act. The Contractor further agrees to comply with any applicable federal, state or local licensing standards, any applicable accrediting standards, and any other applicable standards or criteria established locally or by the state or federal governments.

This agreement shall be governed by and construed in accordance with the laws of the State of California.

Section 9 - NOTICES

All notices shall be in writing and delivered in person or transmitted by mail. Notices required to be given to the COUNTY shall be addressed as follows:

Humboldt County Department of Public Works
1106 Second Street, Eureka, California, 95501

✓ Notices required to be given to CONTRACTOR shall be addressed as follows:

6 Rivers Construction Inc.
P.O. Box 1431
Hoopa Ca. 95546

IN WITNESS WHEREOF, The parties hereto have entered into this Agreement as of the date first above set forth.

COUNTY OF HUMBOLDT

BY 

(SEAL)

Director of Public Works
of the County of Humboldt,
State of California

ATTEST:

KATHY HAYES

Clerk of the Board of Supervisors
of the County of Humboldt,
State of California

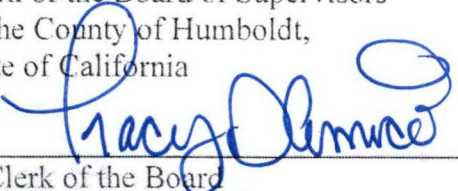
BY 
Clerk of the Board

Tracy Amico, Deputy

✓ CONTRACTOR

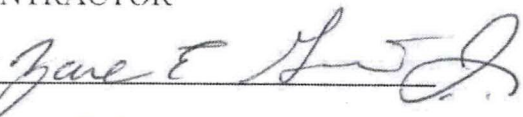
BY 
TITLE CEO

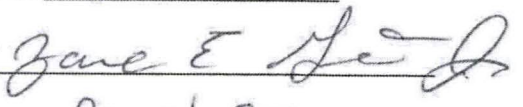
BY 
TITLE President

(Two Signatures Required For Corporation)

APPROVED AS TO FORM:

BY N / A
Deputy County Counsel

INSURANCE CERTIFICATES REVIEWED
AND APPROVED:

BY Phillips, Amanda
Digitally signed by Phillips,
Amanda
Date: 2023.01.04 08:26:41 -08'00'
Risk Manager

ADDENDUM No. 2
BID FORM (EXHIBIT A)
ROAD MAINTENANCE ON BALD HILLS ROAD (F4R300) PM 16.05-19.04
CONTRACT NO.: 321623

ITEM NO.	ITEM CODE	ITEM DESCRIPTION	UNIT	QTY	UNIT PRICE	TOTAL
1	120095	Construction Area Signs	EA	4	1000 -	4,000 -
2	120100	Traffic Control System	LS	1		20,000 -
3	130100	Job Site Management	LS	1		30,000 -
4	130300	Prepare Storm Water Pollution Prevention Plan	LS	1		2,500 -
5	130310	Rain Event Action Plan	EA	3	\$ 1,500.00	4,500 -
6	130320	Storm Water Sampling and Analysis	EA	3	1000	3,000 -
7	130330	Storm Water Annual Report	EA	1	\$ 2,000.00	2,000 -
8	210212	Dry Seed (SQFT)	SQFT	2,800	.20	560 -
9	210420	Straw	SQFT	2,800	.20	560 -
10	260203	F Class 2 Aggregate Base (CY)	CY	6,300	112 -	705,600 -
11	374002	Asphaltic Emulsion (Fog Seal Coat)	TON	20	900 -	18,000 -
12	374493	Polymer Asphaltic Emulsion (Seal Coat)	TON	123	1140 -	140,220 -
13	390132	Hot Mix Asphalt (Type A)	TON	135	222 -	29,970 -
14	665018	18" Corrugated Steel Pipe (.109" Thick)	LF	580	122 -	70,760 -
15	665024	24" Corrugated Steel Pipe (.109" Thick)	LF	60	184 -	11,040 -
16	723070	Rock Slope Protection (150 lb, Class III, Method B)	CY	14	214 -	2,996 -
17	999990	Mobilization (Includes TERO)	LS	1		62,279 -

NOTE: ITEM CODE LETTER DESIGNATION; S=SPECIALITY ITEM, F=FINAL PAY QUANTITY

BID TOTAL

1,107,985 -

Checked by
RD 8/2/2022

ACKNOWLEDGEMENT OF ADDENDA

ADDENDUM NO.

1
2

INITIAL

ZEC
ZEC

(Bidder's Signature)

CEO

(Title)



County of Humboldt
Department of Public Works
1106 Second Street
Eureka, CA 95501
TEL (707) 445-7377

ADDENDUM NO. 1
 (Issued July 19, 2022)

ROAD MAINTENANCE ON BALD HILLS ROAD (F4R300) PM 16.05-19.04
CONTRACT NO.: 321623

The Special Provisions are hereby modified in accordance with the following:

1. Add to section **26-1.04B**:

The aggregate shall have at least 50% crushed particles with at least one fractured face.

2. Replace section **14-4 Native American Concerns** "Reserved" with the following:

14-4A General

The following cultural mitigation measures will be incorporated in this project.

- A cultural monitor will conduct monitoring of construction activities to ensure protection of known sensitive areas and aid in identification of any suspected inadvertent discoveries.
- Should artifacts or archaeological features be exposed during project construction, work shall be immediately halted within a minimum 50-foot-radius of the discovery location (but may continue in other project areas) and the designated points of contact for Humboldt County Public Works and the Yurok Tribe shall be notified. The circumstances of the discovery shall be documented in part, by relying on witnesses including the construction foreman, who shall be held directly accountable for enforcing the stop work order and notifying the points of contact.
- Discovery of known or suspected Native American skeletal remains shall be handled in accordance with applicable laws.

The Contractor's operations are subject to the following constraints and mitigations:

I M P O R T A N T

This Addendum is being sent EMAIL/FAX. To indicate receipt of this Addendum please sign and send back to the Department of Public Works.

EMAIL: PWEngineering@co.humboldt.ca.us
or FAX: (707) 445-7409

Received by:

Gene E. Smith

Date

8-2-22

Company:

6 Rivers Construction Inc.

Pages

Received

3

Total Pages Sent 3

The project site is located in an area which is known to have historical, cultural, and archaeological significance. As such cultural monitors must be onsite whenever any ground disturbing activities are taking place. During the course of the work the Contractor must accommodate the cultural monitors including providing access, stopping work when inspections are necessary and protecting resources when directed.

14-4B SITE CONDITIONS

A. Coordination with the Inspector:

1. Contact the Inspector at least five (5) days in advance of any planned removal of historic fabric, demolition, or ground disturbance work. The Inspector will in turn notify the Yurok Tribe Cultural Monitor when such work is planned.
2. Contractor shall coordinate directly with the Inspector regarding Cultural monitoring. Any ensuing directives from the Yurok Tribe Cultural Monitor in relation to need for interruption of specific contractor work will be made through the Inspector.

B. Limit of Work

1. Contractor shall layout all planned removal, demolition, or ground disturbance work for review and approval prior to such work commencing.
2. Contractor shall avoid all removal, demolition, ground disturbance, and other destructive activities that may disturb historic fabric, artifacts, archaeological, cultural or natural resources until the Inspector gives approval to proceed.

C. Role of Yurok Tribe Cultural Monitor

1. Prior to the construction start date, but during the submittal period, Cultural Monitor will attempt to mark or identify, where certain historical fabric, cultural resources are to be documented, salvaged, or left in place on the building/structure/feature/site as identified in the construction documents. This by no means is meant to indicate that during the course of demolition, ground disturbance, or destructive activities, that the contractor is free to move forward without first obtaining permission to proceed from the Inspector, or that during the course of such actions, new or previously unknown areas will not be marked or identified by the archaeologist/cultural specialist.
2. During construction, Cultural Monitor will monitor all demolition, ground disturbance, or destructive activities.
3. Cultural Monitor will determine whether appropriate treatments such as handwork, will be necessary for certain demolition, ground disturbance, or destructive activities. Directives in relation to need for alteration of technique or interruption of specific contractor work will be given by the Inspector.

(Addendum No. 1)

D. Down Time

1. If unforeseen cultural/natural resources are uncovered during execution of the work, the Inspector will put work on hold at that specific location, and the Contractor will be redirected to other tasks. The Cultural Monitor will record and evaluate the find and implement avoidance, preservation, or recovery measures as appropriate compliance with environmental law and department resource directives prior to Inspector directing resumption of work at that specific location.
2. Contractor shall include in the project schedule, consideration of up to (not less than) five (5) calendar days down time for unforeseen conditions uncovered during execution of work that may require further resource analysis. Down time days must be approved by the Inspector.

14-4C PROTECTION OF EXISTING RESOURCES

A. Provide required protection, in areas identified on drawings, or as directed by the Inspector to maintain integrity of the resources to be protected during the course of the project.

14-4D PAYMENT

Full compensation for cultural monitors and monitoring activities will be covered by the Yurok Tribe.

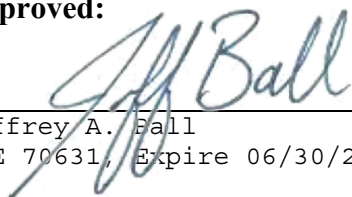
Approved:

Jeffrey A. Ball
RCE 70631, Expire 06/30/2023

7-19-2022

Date



County of Humboldt
Department of Public Works
1106 Second Street
Eureka, CA 95501
TEL (707) 445-7377

ADDENDUM NO. 2
 (Issued July 26, 2022)

ROAD MAINTENANCE ON BALD HILLS ROAD (F4R300) PM 16.05-19.04
CONTRACT NO.: 321623

The Project Plans and Special Provisions are hereby modified in accordance with the following:

1. Per section 2-1.28 of the Special Provisions, the attached forms are made available:
 - a. Yurok Tribe Labor Force Project Form
 - b. Indian Preference Certification
2. Section 37-4.02B of the Special Provisions is hereby modified by the following:
 Asphaltic emulsion for fog seal must be Grade CQS-1H. The supplier will include 10 tons of water with 10 tons of Grade CQS-1H for bid item #11, *Asphaltic Emulsion (Fog Seal Coat)*. The bid item #11 quantity shall be revised from 10 Tons to 20 Tons to account for the water required for the fog seal.
3. Replace Bid Form (Exhibit A) (page 32) with the revised bid form attached to this Addendum.
4. Replace sheet 2 of 3 of the project plans with the attached revised sheet (updated quantity table)

Approved:

Jeff Ball

7-26-2022

Jeffrey A. Ball
 RCE 70631, Expires 06/30/2023

Date

I M P O R T A N T

This Addendum is being sent EMAIL/FAX. To indicate receipt of this Addendum please sign and send back to the Department of Public Works.

EMAIL: PWEngineering@co.humboldt.ca.us
 or FAX: (707) 445-7409

Received by:

Zane E. [Signature]

Date

7-30-22

Company:

6 Rivers Construction Inc

Pages

Received

8

Total Pages Sent 8

TRIBAL EMPLOYMENT RIGHTS OFFICE

190 Klamath Blvd., P.O. Box 1027 Klamath, California 95548 (707) 482-1350 (707) 482-1377 Fax



Jobs in the private employment sector are an important resource on the Yurok Reservation, thus the Yurok Tribe is committed to securing such jobs for its Tribal members and local Indians as they become available. Furthermore, the Tribe helps drive the local economy and asks employers to use local goods and services when developing a project, with first preference given to qualified Indian-owned businesses and entrepreneurs.

Contractor Obligations:

As a contractor/subcontractor conducting business within the Yurok Tribe's Ancestral Territory, or with the Yurok Indian Housing Authority (YIHA), your specific obligations under the Tribal Employment Rights Ordinance (TERO), TERO Permit and Indian Preference Plan include the following:

1. Provide TERO with a precise listing of positions you will use on this project from the superintendent on down, and the number of each craft. Contractors/employees shall be required to hire and maintain as many local Tribal Members as apply for and are qualified for each craft or skill. The order of hiring shall be according to the Tribe's Hiring Preference Policy as follows:
 - Tier 1: Qualified Yurok Tribal Members
 - Tier 2: Spouses of Yurok Tribal Members
 - Tier 3: Other Indians of Federally recognized Tribes
 - Other qualified persons
2. Identification of Core/Key Employees. A Core/Key employee is an employee of a covered employer in a managerial or project supervisory position, or who performs an essential job function as identified on a case by case basis by TERO and prior to issuance of a TERO Permit.
3. The contracting and subcontracting preference shall be manifested through giving bidding preference to Indian-owned businesses. Indian Preference Applications and Certification are obtained through the TERO Office.
4. Inform TERO of all signatory trade unions to be involved in the project. TERO obligations have priority over union obligations by a contractor signatory to any trade unions. However, TERO will consider Indian workers of the trade unions in order for contractors to meet their hiring goals.
5. Notify TERO of all job vacancies. All available Indian applicants shall be considered first before any non-Indians are considered for employment and training. If no qualified Indians are available, TERO will provide a consent form to waive this obligation.

6. Employees referred by the TERO office will have preference in retention of employment from the beginning to the end of the project. Inform TERO of any lay-offs.

7. Before any TERO referral is terminated from the project you must inform TERO immediately to allow for informal counseling.

8. Allow on-site inspections by TERO representatives.

9. Provide copies of certified payroll reports to the TERO office upon request.

10. No work on the scheduled project will begin until all applicable agreements are signed and a TERO Permit has been issued. Failure to sign the required agreements shall serve as just cause for the contractor/subcontractor to be subject to sanction(s) as prescribed in the TERO Ordinance.

11. Any employer, contractor, subcontractor, or union who violates the TERO Ordinance or the rules, regulations, or orders promulgated by the TERO Officer or Council will be subject to penalties for such violations, including the maximum monetary civil penalty permitted under the Indian Civil Rights Act of 1968, 25 U.S.C. § 1302. Every day during which a violation exists shall be deemed a separate occurrence. (See the Yurok Tribe TERO Ordinance, Chapter 8, for Enforcement & Sanctions.)

Certification of Service:

I, Zane E Grant Jr, respectfully submit as evidence by my signature that I understand my obligations of Indian Preference hiring as a contractor conducting business on the Yurok Reservation or with the Yurok Indian Housing Authority. I attest to the fact that the TERO representative whose signature is found below did in fact explain these specific obligations and allowed for an opportunity to represent questions, comment or discussion on these requirements related to this agreement.

Zane E Grant Jr
6 Rivers Construction Inc CEO 8-2-22
Company/Contract Representative Position Date

6 Rivers Construction Inc
Company Name

TERO Representative Position Date

Labor Force Projection - Section A: Project Information

PROJECT: <i>Road Maintenance on BALD HILLS ROAD</i>			
EMPLOYER/SUPPLIER: <i>6 Rivers Construction Inc</i>			
MAILING ADDRESS: <i>PO Box 1431</i>	CITY: <i>Hoopa</i>	STATE: <i>Ca.</i>	ZIP: <i>95546</i>
E-MAIL: <i>6riversconstruction@gmail.com</i>	PHONE: <i>5305157563</i>	FAX: <i>5306255423</i>	CELL:
CONTACT PERSON: <i>Zane "Chip" Grant Jr</i>	PHONE: <i>530 515 7563</i>		
SCOPE OF WORK: <i>Replace culverts, Base Rock, chip seal</i>			
START DATE:		COMPLETION DATE:	
AMOUNT OF CONTRACT:		TERO FEE: 5% of Total Project Cost	

TERO Fee:

With respect to each project/contract or subcontract of \$5,000.00 or more, operating within the exterior boundaries of the Yurok Indian Reservation or with the Yurok Indian Housing Authority, the contractor shall pay a one time fee of 5% of the total project/contract costs (i.e. equipment, labor, materials and operations), and any increase of the contract/project or subcontract amount prior to commencing work. If the covered employer initially enters into a contract/project or subcontract of less than \$5,000.00, but subsequently increases costs, as a result in the total contract/project or subcontract amount of \$5,000.00 or more, the fee shall apply to the total amount including increases.

Checks are to be made payable to: YUROK TRIBE TERO.

Job Qualifications, Personnel Requirements & Cultural Traditions Requirement:

An employer may not use any job qualification criteria or personnel requirements which serve as barriers to the employment of Native Americans which are not required by business necessity. Any education &/or certification(s) required of TERO members for employment must also be provided for all employees of the covered employers within the same classification. The TERO Officer will review the job duties and may require the employer to eliminate the personnel requirements at issue. Employers shall also make reasonable accommodation to the tribal holidays and cultural traditions of Native workers.

Labor Force Projection - Section B: Work Force

Core/Key Employees:

Name	Position	Wage	Hire Date	Native: Y/N
Zane Grant Jr	Operator		2011	Y
Wally Marton	Operator		2011	Y
Zane Grant III	Labor		2020	Y
Dason Wilder	Driver		2011	Y
Robby Moon	Labor		2011	Y

Tribal Member Hiring:

The TERO representative shall establish and administer a Tribal hiring opportunity to assist employers in placing preferred employees in job positions. An employer may recruit and hire workers from whatever sources are available to them to achieve the same preference hiring goals, but is subject to inform the TERO representative. The employer may not employ a non-local Indian until the employer has given the TERO office 72 hours to locate and refer a qualified local Indian.

Positions needed for Project	# of Positions	Wage	Start Date/End Date

Contracting & Subcontracting:

The preference requirements contained in the TERO Ordinance shall be binding on all contractors and subcontractors, regardless of tier, and shall be deemed a part of all resulting subcontract specifications. The covered employer shall have the initial and primary responsibility for ensuring that all contractors and subcontractors comply with these requirements. TERO Certified Indian Firms that are qualified and come within 5% of the low bid, will be provided negotiated preference.

All Subcontractors must submit an Indian Preference Plan to be negotiated with TERO.

Labor Force Projection - Section C: Compliance

I declare that all the answers and statements are true, correct and complete to the best of my knowledge. I understand that untruthful or misleading answers are cause for denial of my application and may follow under the Yurok Tribe TERO Ordinance, Chapter 8:

Enforcement and Sanctions - A covered employer who violates this ordinance shall be subject to sanctions for such violations. Such sanctions shall be remedial in nature and shall be designed and intended to compel compliance, prevent future violation, or compensate injured parties and shall include, but not be limited to:

- Denial of right to commence or continue business or contracts inside the Yurok Indian Reservation, with a Tribal entity, or involving Tribal funds;
- Suspension of all operations inside the Reservation;
- Debarment or prohibition from engaging in commerce or contracts on Yurok lands;
- Payment of back pay and damages to compensate any injured party;
- An order to stop work until the provisions of the TERO ordinance are satisfied;
- An order to summarily remove employees hired in violation of the TERO Ordinance;
- An order requiring employment, promotion and training of Indians injured by the violation;
- An order mandating changes in procedures and policies necessary to eliminate or correct the violation;
- An order making any other provisions deemed by the Tribal Council and Tribal Court to alleviate, eliminate or compensate for any violation; and
- Imposition of monetary civil penalties for each violation. Each day during which a violation exists shall constitute a separate violation.

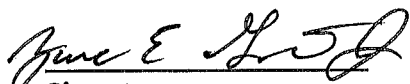
Signature

Zane E. Grant Jr
Print Name

CEO
Title

03-2-22
Date

Please submit application to: Yurok Tribe TERO P.O. Box 1027 Klamath, CA. 95548 or
msanchez@yuroktribe.nsn.us

**ADDENDUM No. 2
 BID FORM (EXHIBIT A)
 ROAD MAINTENANCE ON BALD HILLS ROAD (F4R300) PM 16.05-19.04
 CONTRACT NO.: 321623**

ITEM NO.	ITEM CODE	ITEM DESCRIPTION	UNIT	QTY	UNIT PRICE	TOTAL
1	120095	Construction Area Signs	EA	4		
2	120100	Traffic Control System	LS	1		
3	130100	Job Site Management	LS	1		
4	130300	Prepare Storm Water Pollution Prevention Plan	LS	1		
5	130310	Rain Event Action Plan	EA	3	\$ 1,500.00	
6	130320	Storm Water Sampling and Analysis	EA	3		
7	130330	Storm Water Annual Report	EA	1	\$ 2,000.00	
8	210212	Dry Seed (SQFT)	SQFT	2,800		
9	210420	Straw	SQFT	2,800		
10	260203	F Class 2 Aggregate Base (CY)	CY	6,300		
11	374002	Asphaltic Emulsion (Fog Seal Coat)	TON	20		
12	374493	Polymer Asphaltic Emulsion (Seal Coat)	TON	123		
13	390132	Hot Mix Asphalt (Type A)	TON	135		
14	665018	18" Corrugated Steel Pipe (.109" Thick)	LF	580		
15	665024	24" Corrugated Steel Pipe (.109" Thick)	LF	60		
16	723070	Rock Slope Protection (150 lb, Class III, Method B)	CY	14		
17	999990	Mobilization (Includes TERO)	LS	1		

NOTE: ITEM CODE LETTER DESIGNATION; S=SPECIALITY ITEM, F=FINAL PAY QUANTITY

BID TOTAL

ACKNOWLEDGEMENT OF ADDENDA

ADDENDUM NO. INITIAL
 _____ _____
 _____ _____
 _____ _____

(Bidder's Signature)

(Title)

ADDENDUM NO. 2

1 REVISED QUANTITY TABLE (BID ITEM NO. 11)



BAR IS ONE INCH ON ORIGINAL DRAWING IF NOT ONE INCH ON THIS SHEET, ADJUST SCALES ACCORDINGLY	ROAD NAME: BALD HILLS ROAD	DESIGN SECTION: ENGINEERING	COUNTY OF HUMBOLDT Attachment 2 DEPARTMENT OF PUBLIC WORKS	SHEET 2 OF 3
	ROAD NO.: F4R300	MILE POST: 16.05-19.04		
	AGREEMENT NO.: ER 4400(046)	DRAWN BY: MMS	BALD HILLS ROAD PM 16.05-19.04 MAINTENANCE PROJECT	
	CONTRACT NO.: 321623	REVIEWED BY: JAB	TRAFFIC CONTROL PLAN AND QUANTITIES	
	DRAWING FILE NAME: Bald_Hills_Rd_Design	APPROVED BY: TRS		
	PLOT DATE: 6/21/2022			

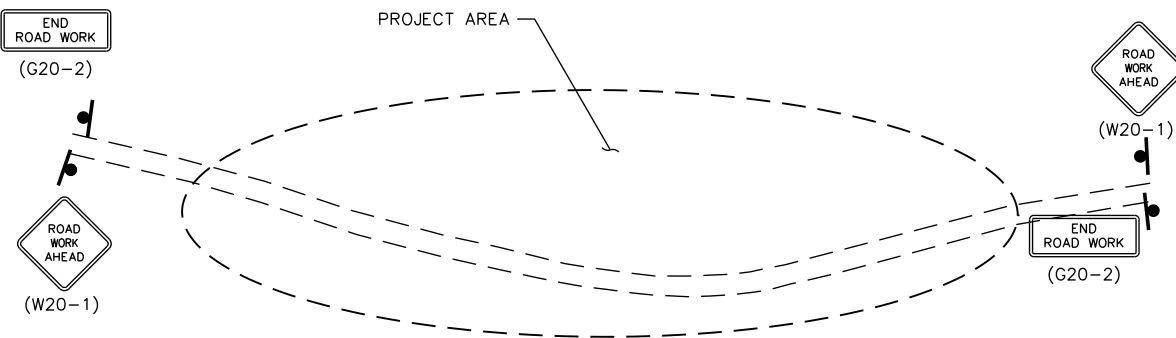

QUANTITIES

ITEM NO.	ITEM CODE	ITEM DESCRIPTION	UNIT	QUANTITY
1	120095	Construction Area Signs	EA	4
2	120100	Traffic Control System	LS	1
3	130100	Job Site Management	LS	1
4	130300	Prepare Storm Water Pollution Prevention Plan	LS	1
5	130310	Rain Event Action Plan	EA	3
6	130320	Storm Water Sampling and Analysis	EA	3
7	130330	Storm Water Annual Report	EA	1
8	210212	Dry Seed (SQFT)	SQFT	2,800
9	210420	Straw	SQFT	2,800
10	260203	F Class 2 Aggregate Base (CY)	CY	6,300
11	374002	Asphaltic Emulsion (Fog Seal Coat)	TON	20
12	374493	Polymer Asphaltic Emulsion (Seal Coat)	TON	123
13	390132	Hot Mix Asphalt (Type A)	TON	135
14	665018	18" Corrugated Steel Pipe (.109" Thick)	LF	580
15	665024	24" Corrugated Steel Pipe (.109" Thick)	LF	60
16	723070	Rock Slope Protection (150 lb, Class III, Method B) (CY)	CY	14
17	999990	Mobilization (Includes TERO)	LS	1

TYPICAL TRAFFIC CONTROL PLANS

SCALE: 1"=200'±

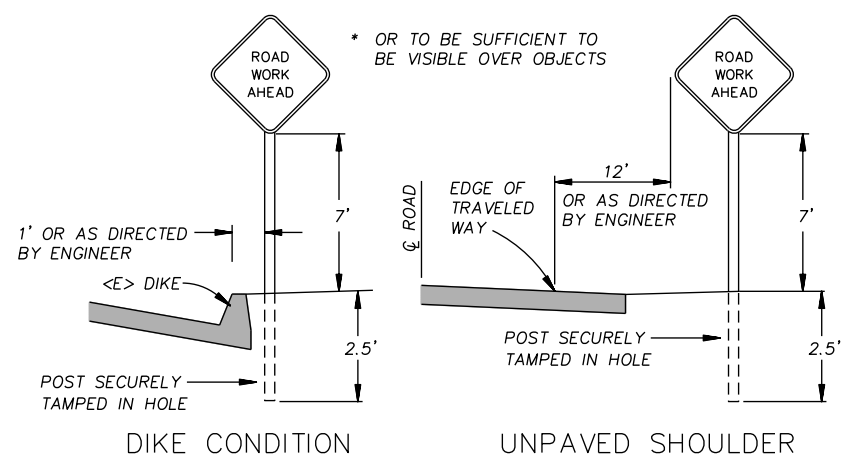

RURAL CONSTRUCTION AREA SIGN

- NOT TO SCALE -

NOTES

- SIGNS SHALL BE PLACED AS SHOWN ON PLAN, TABLE 1 & 2, AND/OR AS DIRECTED BY THE ENGINEER.
- FINAL PLACEMENT OF SIGNS SHALL BE APPROVED BY RESIDENT ENGINEER.
- ADDITIONAL PORTABLE SIGNS SHALL BE USED AS REQUIRED FOR OTHER ROADSIDE WORK.
- SEE CALTRANS STANDARD PLANS T13 FOR TRAFFIC CONTROL SYSTEM IF A SINGLE-LANE DETOUR IS DEEMED NECESSARY FOR CONSTRUCTION BY THE ENGINEER.
- IN ADDITION TO CONSTRUCTION AREA SIGNS AND WHEN DIRECTED BY THE RESIDENT ENGINEER, THE CONTRACTOR SHALL UTILIZE FLAGMEN AS NECESSARY TO DIRECT TRAFFIC.
- KEEP A MINIMUM OF 1 TRAFFIC LANE AT LEAST 10 FEET WIDE OPEN FOR TRAFFIC, EXCEPT THE FULL WIDTH OF THE TRAVELED WAY (18' MINIMUM) MUST BE OPEN WHEN CONSTRUCTION OPERATIONS ARE NOT ACTIVE OR AN APPROVED TRAFFIC CONTROL PLAN IS IN PLACE.
- WHEN DEVELOPING A DETOUR WITH A ONE-LANE, TWO-WAY TRAFFIC CONTROL SYSTEM, ADD A TRAFFIC TAPER TO BOTH ENDS OF THE DETOUR PER FIGURE 6C-3 OF THE CA MUTCD

CONSTRUCTION AREA SIGN SUMMARY

SIGN CODE	QTY	SIGN MESSAGE	PANEL SIZE	NUMBER & POST SIZE
G20-2	2	END ROAD WORK	36" x 18"	(1) 4" x 4"
W20-1	2	ROAD WORK AHEAD	36" x 36"	(1) 4" x 4"

COUNTY OF HUMBOLDT
DEPARTMENT OF PUBLIC WORKS
1106 SECOND STREET
EUREKA, CA 95501

CONTRACT CHANGE ORDER

CONTRACT CHANGE ORDER NUMBER	1	SUPL. NO.	
------------------------------	---	-----------	--

DATE PREPARED BY RESIDENT ENGINEER: October 27, 2023

PROJECT NAME: ROAD MAINTENANCE ON BALD HILLS ROAD P.M. 16.05-19.04

PROJECT NO. N/A CONTRACT NO. 321623

TO: 6 RIVERS CONSTRUCTION, INC., P.O. BOX 1431, HOOPA, CA 95546

YOU ARE HEREBY DIRECTED TO MAKE THE HEREIN DESCRIBED CHANGES FROM THE PLANS AND SPECIFICATIONS OR TO DO THE FOLLOWING DESCRIBED WORK NOT INCLUDED IN THE PLANS AND SPECIFICATIONS FOR THIS CONTRACT. NOTE THIS CHANGE ORDER IS NOT EFFECTIVE UNTIL APPROVED BY THE DIRECTOR OF PUBLIC WORKS

DESCRIPTION OF WORK TO BE DONE, ESTIMATE OF QUANTITIES, AND PRICES PAID. (SEGREGATE BETWEEN ADDITIONAL WORK AT CONTRACT PRICE, AGREED PRICE AND FORCE ACCOUNT.) UNLESS OTHERWISE STATED, RATES FOR RENTAL OF EQUIPMENT COVER ONLY SUCH TIME AS EQUIPMENT IS ACTUALLY USED AND NO ALLOWANCE WILL BE MADE FOR IDLE TIME. THE LAST PERCENTAGE SHOWN IS THE NET ACCUMULATED INCREASE OR DECREASE FROM THE ORIGINAL QUANTITY IN THE ENGINEER'S ESTIMATE.

EXTRA WORK AT AGREED PRICE

- 1a Remove and salvage cattle guard and backfill and compact disturbed area \$ 2,500.00
- 1b Remove and replace culverts at greater depths than shown on project plans \$ 5,810.32

For this work, the contractor shall receive and accept the agreed lump sum of **\$8,310.32**. This sum constitutes full and complete compensation for furnishing all labor, material, equipment, tools, and incidentals including all markups by reason of this change.

A determination of the delay in completion of the contract due to the work specified by Change Order No. 1 has been made in accordance with the provisions of Section 8-1.07, "Delays," of the Standard Specifications.

Four (4) working days shall be granted for the delay in controlling operations resulting from this change order.

ESTIMATED TOTAL INCREASE = \$ 8,310.32

BY REASON OF THIS CHANGE, THE CONTRACT TIME WILL BE INCREASED BY **4 DAYS**

SUBMITTED BY:

SIGNATURE <i>Angi Sorensen</i>	PRINT NAME AND TITLE ANGI SORENSEN, CONSTRUCTION ENGINEER	DATE <i>11-3-23</i>
-----------------------------------	--	------------------------

DIRECTOR APPROVAL BY:

SIGNATURE <i>Tom Mattson</i>	PRINT NAME AND TITLE TOM MATTSO, DIRECTOR OF PUBLIC WORKS	DATE <i>11/3/23</i>
---------------------------------	--	------------------------

WE, THE UNDERSIGNED CONTRACTOR, HAVE GIVEN CAREFUL CONSIDERATION TO THIS CHANGE PROPOSED AND AGREE, IF THIS PROPOSAL IS APPROVED, THAT WE WILL PROVIDE ALL EQUIPMENT, FURNISH ALL MATERIALS, EXCEPT AS MAY OTHERWISE BE NOTED ABOVE, AND PERFORM ALL SERVICES NECESSARY FOR THE WORK ABOVE SPECIFIED, AND WILL ACCEPT AS FULL PAYMENT, THEREFORE, THE PRICES SHOWN ABOVE. NOTE: IF YOU, THE CONTRACTOR, DO NOT SIGN ACCEPTANCE OF THIS ORDER, YOUR ATTENTION IS DIRECTED TO THE REQUIREMENTS OF THE SPECIFICATION AS TO PROCEEDING WITH THE ORDERED WORK AND FILING A WRITTEN PROTEST WITHIN THE TIME THEREIN SPECIFIED.

CONTRACTOR ACCEPTANCE BY:

SIGNATURE <i>Jane E. Grant Jr</i>	PRINT NAME AND TITLE Jane E. Grant Jr. owner	DATE <i>11/2/23</i>
--------------------------------------	---	------------------------

CONTRACT CHANGE ORDER NUMBER	2	SUPPL. NO.	
------------------------------	---	------------	--

DATE PREPARED BY RESIDENT ENGINEER: July 19, 2024

PROJECT NAME: ROAD MAINTENANCE ON BALD HILLS ROAD P.M. 16.05-19.04

PROJECT NO. N/A CONTRACT NO. 321623

TO: 6 RIVERS CONSTRUCTION, INC., P.O. BOX 1431, HOOPA, CA 95546

YOU ARE HEREBY DIRECTED TO MAKE THE HEREIN DESCRIBED CHANGES FROM THE PLANS AND SPECIFICATIONS OR TO DO THE FOLLOWING DESCRIBED WORK NOT INCLUDED IN THE PLANS AND SPECIFICATIONS FOR THIS CONTRACT. **NOTE THIS CHANGE ORDER IS NOT EFFECTIVE UNTIL APPROVED BY THE DIRECTOR OF PUBLIC WORKS**

DESCRIPTION OF WORK TO BE DONE, ESTIMATE OF QUANTITIES, AND PRICES PAID. (SEGREGATE BETWEEN ADDITIONAL WORK AT CONTRACT PRICE, AGREED PRICE AND FORCE ACCOUNT.) UNLESS OTHERWISE STATED, RATES FOR RENTAL OF EQUIPMENT COVER ONLY SUCH TIME AS EQUIPMENT IS ACTUALLY USED AND NO ALLOWANCE WILL BE MADE FOR IDLE TIME. THE LAST PERCENTAGE SHOWN IS THE NET ACCUMULATED INCREASE OR DECREASE FROM THE ORIGINAL QUANTITY IN THE ENGINEER'S ESTIMATE.

INCREASE IN CONTRACT ITEMS AT CONTRACT PRICES

ITEM NO. 10	CLASS 2 AGGREGATE BASE (CY)					
	235.0 CY	3.73%	@	\$ 112.00	/ CY	\$ 26,320.00
ITEM NO. 11	ASPHALTIC EMULSION (FOG SEAL COAT)					
	0.21 TN	1.05%	@	\$ 900.00	/ TN	\$ 189.00
ITEM NO. 13	HOT MIX ASPHALT (TYPE A)					
	114.69 TN	84.96%	@	\$ 222.00	/ TN	\$ 25,461.18
ITEM NO. 16	ROCK SLOPE PROTECTION (150 LB, CLASS III, METHOD B) (CY)					
	35.0 CY	250.00%	@	\$ 214.00	/ CY	\$ 7,490.00
TOTAL INCREASE =						\$ 59,460.18

No adjustment to contract unit price for Item No. 13, Hot Mix Asphalt (Type A), will be made in accordance with Section 9-1.06B, "Increases of More Than 25 Percent," of the Standard Specifications by reason of this change order.

DECREASE IN CONTRACT ITEMS AT CONTRACT PRICES

ITEM NO. 5	RAIN EVENT ACTION PLAN					
	-2 EA	-66.67%	@	\$ 1,500.00	/ EA	\$ (3,000.00)
ITEM NO. 6	STORM WATER SAMPLING AND ANALYSIS					
	-2 EA	-66.67%	@	\$ 1,000.00	/ EA	\$ (2,000.00)
ITEM NO. 8	DRY SEED (SQFT)					
	-2800 SF	-100.00%	@	\$ 0.20	/ SF	\$ (560.00)
ITEM NO. 12	POLYMER ASPHALTIC EMULSION (SEAL COAT)					
	-6.89 TN	-5.60%	@	\$ 1,140.00	/ TN	\$ (7,854.60)
ITEM NO. 14	18" CORRUGATED STEEL PIPE (0.109" THICK)					
	-117 LF	-20.17%	@	\$ 122.00	/ LF	\$ (14,274.00)
ITEM NO. 15	24" CORRUGATED STEEL PIPE (0.109" THICK)					
	-14 LF	-23.33%	@	\$ 184.00	/ LF	\$ (2,576.00)
TOTAL DECREASE =						\$ (30,264.60)

In accordance with Section 9-1.06D, "Eliminated Items," of the *Standard Specifications*, the adjustment due to the elimination of Item No. 8, Dry Seed (SQFT), is zero.

In accordance with Section 9-1.17D, Final Payment and Claims, of the Contract Special Provisions, grant the contractor twenty-six (26) working days, eliminating the overrun in contract time and providing for a full settlement of all claims for time on this contract.

ESTIMATED TOTAL INCREASE = \$ 29,195.58

BY REASON OF THIS CHANGE, THE CONTRACT TIME WILL BE INCREASED BY 26 WORKING DAYS

SUBMITTED BY:

SIGNATURE	PRINT NAME AND TITLE	DATE
	ANGI SORENSEN, CONSTRUCTION ENGINEER	

DIRECTOR APPROVAL BY:

SIGNATURE	PRINT NAME AND TITLE	DATE
	TOM MATTSON, DIRECTOR OF PUBLIC WORKS	

WE, THE UNDERSIGNED CONTRACTOR, HAVE GIVEN CAREFUL CONSIDERATION TO THIS CHANGE PROPOSED AND AGREE, IF THIS PROPOSAL IS APPROVED, THAT WE WILL PROVIDE ALL EQUIPMENT, FURNISH ALL MATERIALS, EXCEPT AS MAY OTHERWISE BE NOTED ABOVE, AND PERFORM ALL SERVICES NECESSARY FOR THE WORK ABOVE SPECIFIED, AND WILL ACCEPT AS FULL PAYMENT, THEREFORE, THE PRICES SHOWN ABOVE. **NOTE: IF YOU, THE CONTRACTOR, DO NOT SIGN ACCEPTANCE OF THIS ORDER, YOUR ATTENTION IS DIRECTED TO THE REQUIREMENTS OF THE SPECIFICATION AS TO PROCEEDING WITH THE ORDERED WORK AND FILING A WRITTEN PROTEST WITHIN THE TIME THEREIN SPECIFIED.**

CONTRACTOR ACCEPTANCE BY:

SIGNATURE	PRINT NAME AND TITLE	DATE