



Site Management Plan

(Tier 1, High Risk)

WDID- 1_12CC407765

Humboldt County
APN: 221-221-008

Prepared by:



165 South Fortuna Boulevard, Fortuna, CA 95540
707-725-1897 • fax 707-725-0972
trc@timberlandresource.com

4/19/2019

ENC 030

Arrangement of Document Contents

- Purpose
- Tier Designation
- Scope of Report
- Methods
- Property Description
- Project Description
- General Location Map
- Additional Project Permitting
- General Compliance Guide for Cannabis Cultivators
 - Land Development and Maintenance, Erosion Control, and Drainage Features
 - Cleanup, Restoration, and Mitigation
 - Stream Crossing Installation and Maintenance
 - Soil Disposal and Spoils Management
 - Riparian and Wetland Protection and Management
 - Water Storage and Use
 - Fertilizers, Pesticides, and Petroleum Products
 - Cultivation Related Waste
 - Refuse and Domestic Waste
 - Annual Winterization Measures
- Statement of Limitations
- Site Maps
- Implementation Schedule
- Mitigation Report tables
- Applicable BPTC's (BMP's)
- Monitoring Plan
- Attachments
- Applicable Technical Documents
 - Site Management Plan (SMP)
 - Disturbed Area Stabilization Plan (High Risk)
- Pictures

Purpose

This Site Management Plan (SMP) has been prepared on behalf of the cannabis cultivator for the Humboldt County property identified as assessor parcel numbers 221-221-008, by agreement and in response to the State Water Resources Control Board Cannabis Cultivation Policy (Cannabis Policy), in congruence with Order WQ 2017-0023-DWQ General Waste Discharge Requirements for Discharges of Waste Associated with Cannabis Cultivation Activities (General Order). The General Order implements the Cannabis Policy requirements, specifically those requirements that address waste discharges associated with cannabis cultivation activities. Cannabis cultivators covered under the General Order are subject to the requirements of the Cannabis Policy in its entirety. The Cannabis Policy provides a statewide tiered approach for permitting discharges and threatened discharges of waste from cannabis cultivation and associated activities, establishes a personal use exemption standard, and provides conditional exemption criteria for activities with a low threat to water quality.

Tier Designation

Tiers are defined by the amount of disturbed area. Tier 1 outdoor commercial cultivation activities disturb an area equal to or greater than 2,000 square feet and less than 1 acre (43,560 square feet). Tier 2 outdoor commercial cultivation activities disturb an area equal to or greater than 1 acre. Risk designation for Tier 1 and Tier 2 enrollees under the Cannabis Policy is based on the slope of disturbed areas and the proximity to a surface water body. Characterization is based on the risk designation summarized in Table 1 below.

Table 1: Summary of Risk Designation

Low Risk	Moderate Risk	High Risk
<ul style="list-style-type: none">No portion of the disturbed area is located on a slope greater than 30 percent, andAll of the disturbed area complies with the setback requirements.	<ul style="list-style-type: none">Any portion of the disturbed area is located on a slope greater than 30 percent, andAll of the disturbed area complies with the setback requirements.	<ul style="list-style-type: none">Any portion of the disturbed area is located within the setback requirements.

Thorough assessment of the project area including roads, disturbed areas, legacy features, and cultivation areas classify this enrollment into the **Tier 1, High Risk** designation.

Scope of Report

Tier 1 and Tier 2 cannabis cultivators are required to submit and implement a Site Management Plan that describes how they are complying with the Requirements listed in Attachment A. The description shall describe how all applicable Best Practicable Treatment or Control (BPTC) measures are implemented. Cannabis cultivators within the North Coast Regional Water Quality Control Board jurisdiction are required to submit and implement Site Management Plans that describe how the Requirements are implemented property-wide, to include legacy activities. The SMP includes an Implementation Schedule to achieve compliance, but all work must be completed by the onset of the Winter Period each year. Projects designated as Moderate Risk are also required to have a Site Erosion and Sediment Control (plan) to achieve the goal of minimizing the discharge of sediment off-site. Projects designated as High Risk are also required to have a Disturbed Area Stabilization Plan to achieve the goal of stabilizing the disturbed area to minimize the discharge of sediment off-site and comply with the setback requirements. The cannabis cultivator shall ensure that all site operating personnel are familiar with the contents of the General Order and all technical reports prepared for the property. Projects which have over one acre of cannabis cultivation (total canopy area) are also required to have a Nitrogen Management Plan to describe how nitrogen is stored, used, and applied to crops in a way that is protective of water quality. A copy of the General Order, and technical reports required by the General Order, shall be kept at the cultivation site. Electronic copies of these documents are acceptable. Either format of maintained documents kept on site must be immediately presentable upon request.

Methods

The methods used to develop this SMP include both field and office components. The office component consisted of aerial photography review and interpretation, existing USGS quad map review, GIS mapping of field data, review of on-site photography points, streamflow calculations, general planning, and information gathered from the cannabis cultivator and/or landowner. The field component included mapping of all access roads, vehicle parking areas, Waters of the State, stream crossings, drainage features, cultivation sites, buildings, disturbed areas, and all other relevant site features within the project area and surrounding areas (as feasible). Cultivation areas, associated facilities, roads, and other developed and/or disturbed areas were assessed for discharges and related controllable water quality factors from the activities listed in the General Order. The field assessment also included an evaluation and determination of compliance with all applicable BPTC's per Section 2 of the General Order.

Property Description

The property assessed consists of a 34-acre parcel located approximately 3.5 miles northwest of Briceland, California, at an elevation of approximately 800 feet above mean sea level. The property is located in Section 9, T4S, R2E, HB&M, Humboldt County, of the Ettersburg USGS 7.5' Quad. Blue Slide Creek flows southeast-northwest through the property, which is tributary to the Mattole River.

Project Description

Cannabis cultivation on the property consists of two 120' x 20' greenhouses, two 50' x 20' greenhouses, one 80' x 20' greenhouse, one 100' x 20' greenhouse, one 60' x 20' greenhouse, and one 40' x 20' nursery greenhouse, for a total, general cultivation area¹ of 12,400 ft². The cultivation areas are located within 27,820 ft² of disturbed area. There is a total of approximately 29,280 ft² of disturbed area on the property. This project being permitted by Humboldt County to cultivate to cultivate cannabis. This project was not previously enrolled in the North Coast Regional Water Quality Control Board Order No. R1-2015-0023. This project is being classified as Tier 1, High Risk.

Table 1: Cultivation Site Parameters.

Cultivation Area	Land Disturbance Area (ft ²)	General Cultivation Area ¹ (ft ²)	Adjoining Hillslopes (% Grade)
A	23,000	10,400	15 – 25%
B	3,670	2,000	15%
Totals:	27,820	12,400	

Table 2: Project Permitting


Additional Required Permits Related to Project, Type, and Status	
SIUR	Small Irrigation and Use Registration - Filed with Division of Water Rights #H500635
LSA-1600	Final Agreement from CDFW - Notification No. 1600-2016-0311-R1
401	Required
404	Required

¹ General cultivation area refers to definable areas or groupings of closely situated cannabis cultivation. This designation does not, in any way, reflect the actual cannabis canopy area permitted or present during the assessment of the project area.

Site Management Plan

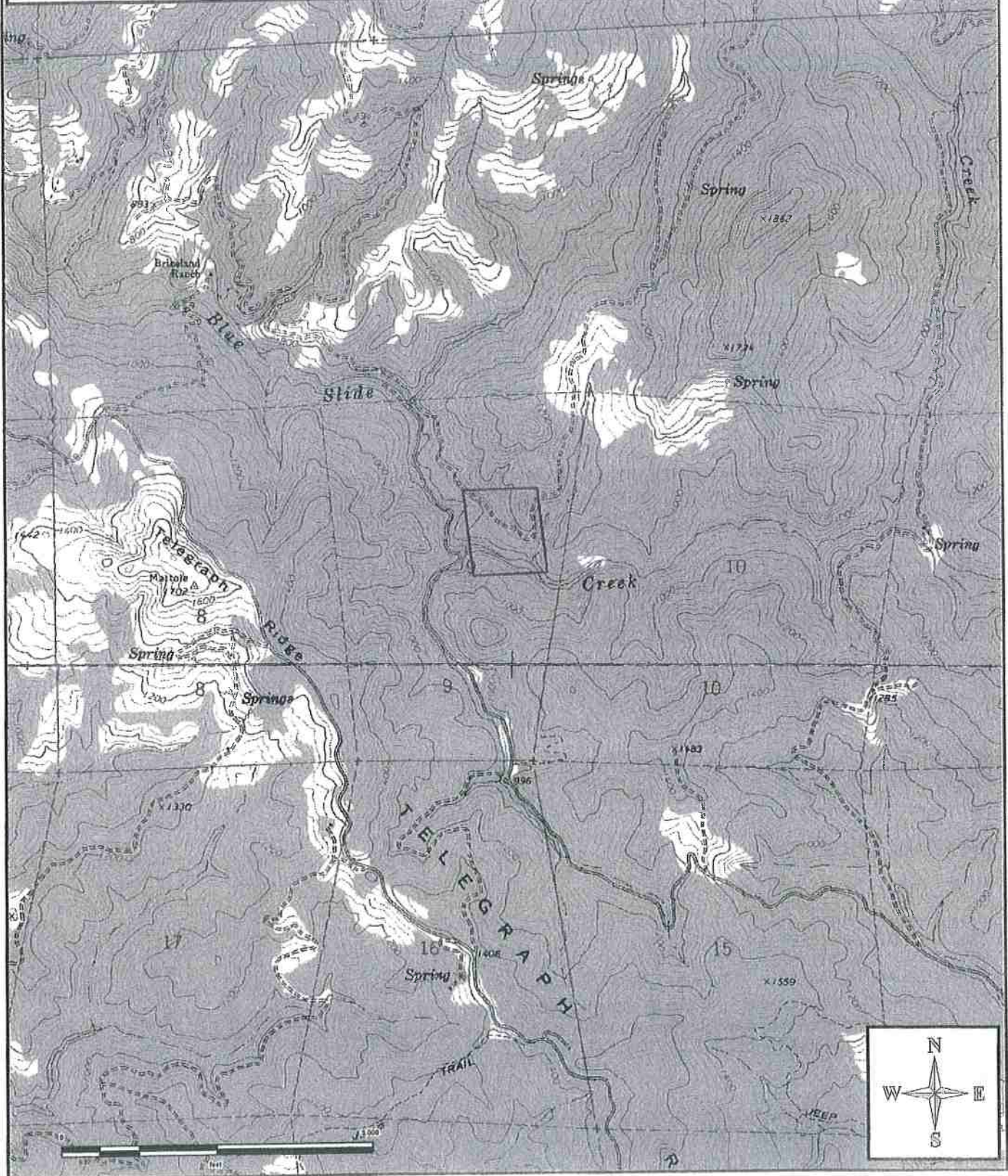
General Location Map [WDID - 1_12CC407765]



 Property Boundary

Located in Section 9, T4S, R2E, HB&M, Humboldt County, from the Ettersburg 7.5' USGS Quad Map

TRC - 430



Baseline Assessment of Requirements Related to Water Diversions and Waste Discharge for Cannabis Cultivation

This project is newly enrolled in the State Water Quality Control Board Order No. WQ 2017-0023-DWQ.

Land Development and Maintenance, Erosion Control, and Drainage Features

Project Compliance Y /N

Roads are being classified as "permanent" (roads appurtenant to the project being used year-round), "seasonal" (roads appurtenant to the project being used primarily during summer months), and "foot trail" (being used for regular or occasional access to features on the property).

Roads within the project area appear to have a moderate to low native rock component and, based on observations of surface erosion relative to current surface drainage break frequency, are being classified as having moderate erodibility. This classification will be utilized to determine surface/ditch-line drainage break frequency based on Table 19 of the Handbook for Forest Ranch and Rural Roads, 2014.

TABLE 19. Recommended maximum rolling dip and ditch relief culvert spacing, in feet, based on road gradient and soil erodibility ^{1, 2}

Soil erodibility	Road gradient (%) and drainage structure spacing (feet)				
	2-3	4-6	7-9	10-12	>12
High to moderate	250	100	130	115	100
Low	400	300	250	200	150

Currently, all roads on the property have native surfaces. Roads being classified as permanent shall be appropriately surfaced (crushed rock, lignin treatments, pavement, or chip-seal) to increase durability during winter use.

Roads assessed by TRC were found to be in inadequate condition with native surfacing and lack adequate rock surfacing and drainage features to allow surface/ditch-line water drainage. Crooked Prairie/West Fork Road (Sites 01 to Site 09) lacks adequate drainage features and a functioning ditch-line. This is resulting in concentrated road surface runoff eroding the road surface. Ditch flows are also jumping the inside ditch at this location. Runoff is either traveling down the road surface into the watercourse crossing at Site 01, or it is draining onto the property access road between Site 04 and 05 where it is eroding the access road (Site 11) and discharging into surface waters at Site 16. Wheel ruts were observed at two locations (Sites 06 & 19) on access roads on the date of the site visit.

No erosion was observed at any of the cultivation areas.

Controllable Sediment Delivery Sites (CSDS) were found on the property. Runoff and sediment from Sites 03, 04, 05, 06, 07, 08, & 09 are discharging into surface waters at the watercourse

crossing at Site 01. Runoff and sediment from Sites 05, 06, 07, 08, 09, 10, & 14 are discharging into surface waters at the head of a Class III watercourse at Site 15. Runoff and sediment from Sites 18 & 19 are discharging into surface waters at the head of a Class III watercourse at Site 20. See the Mitigation Report, Treatment Implementation Schedule, and Site Map to follow for site specific details.

No unstable areas were observed.

Cleanup, Restoration, and Mitigation:

Project Compliance Y/N

No revegetation besides seeding and mulching disturbed areas or sediment catchment sites are being prescribed.

Stream Crossing Installation and Maintenance:

Project Compliance Y/N

One watercourse crossing (Site 01) was identified during the assessment of the property. This crossings culvert shall be replaced as the existing culvert is undersized for a 100-year storm, damaged, installed incorrectly, and shotgunned. See the Mitigation Report, Treatment Implementation Schedule, and Site Map to follow for site specific details.

A Lake and Streambed Alteration Agreement (LSAA/1600) with California Department of Fish & Wildlife (CDFW) has been finalized as of the writing of this assessment for the use of the Point of Diversion but not proposed work on watercourse crossings. Work in watercourses at Site 01 will require a new LSAA/1600 with CDFW. Any additional guidelines, treatments, or restrictions set forth under the finalized Lake and Stream Agreement shall be followed.

Table 3: Stream Crossing Hydrology

Watershed Point Input Values						
ID_NUMBER	D_AREA (ac)	K_VALUE	ELEV_D (ft)	LENGTH (mi)	CMP_DIA (in)	
1	18	0.35	540	0.3	18	

Precipitation Depth-Duration-Frequency Values

Mean Annual Rainfall (in) =

50-Year Storm			100-Year Storm		
Time, Min	Depth (in)	Inch/hr.	Time, Min.	Depth (in)	Inch/hr.
10	0.400	2.40	10	0.614	3.68

ID#	Runoff Coef.	Altitude Index	Time of Concn.	24-hr. Rainfall Intensity	Mean Annual Rainfall	Drainage Area	Selected Discharge Method	Q 100	
	(K)	(1000's ft.)	(min)	(in/hr)	(in)	(ac)		(cfs)	(cfs)
1	0.35	0.0	3	3.68	51	18	RATIONAL	23	19

ID#	Existing Culvert (D)	Headwall (HW)	Selected HW/D	Discharge Method	Q100 (cfs)	Culvert Capacity (cfs)	Culvert is Undersized	Recommended Culvert Dia. (in)	Recommendation Based On
	(in)	(in)	(ratio)						
1	18	0	0.0	RATIONAL	23	6	TRUE	42	Q100

Soil Disposal and Spoils Management:Project Compliance Y/N

Currently, no spoils are present on the property. Any/all spoils generated through development or maintenance of roads, driveways, earthen fill pads, or other cleared or filled areas have not been sidecast in any location where they can enter or be transported to surface waters. Any/all future spoils generated as a result of any future construction projects that are to be stored on the property shall be done so in accordance with the BTPC.

Cultivation-related soils have been disposed of at Site 27, within the riparian setback of a Class II watercourse.

Riparian and Wetland Protection and Management:Project Compliance Y/N

Disturbed areas were identified as being within the riparian setbacks. The removal of cultivation-related wastes, spoils, and other related debris along with the application of erosion control measures described will lead to project compliance. See below. (Sites 12, 13, 15, 20, 24, 25, 26, 27, 28, 29, and Cultivation Area A & B.)

Sections of disturbed area and cultivation area associated with Cultivation Area A was found to be within the outer edges of the 150' riparian setbacks of Blue Slide Creek (Class I) and the 50' riparian setbacks of two Class III watercourses. This cultivation area is located along the edge of a geographic bench feature above Blue Slide Creek where slopes are gentle to moderate (5 – 25%) before reaching the edge of the bench feature where slopes immediately increase to steep slopes (100 – 130%). Riparian setbacks were measured along their actual distance from the edge of the bankfull stage of Blue Slide Creek. No evidence of sidecast fill material or erosion, and associated sediment discharge, associated with this cultivation area was found entering the watercourses. However, at Site 15, surface runoff from a cultivation area and a cultivation soil pile (Site 14) was found combining with concentrated road surface runoff from Site 10 and discharging into the head of a Class III watercourse. See Cultivation Area A on the attached Mitigation Report.

Sections of disturbed area and cultivation area associated with Cultivation Area B was found to be within the riparian setbacks of a Class III watercourse. The northwestern edges of the cultivation area are located within 40' – 45' feet of a Class III watercourse. No evidence of sidecast fill material, erosion and associated sediment discharge, or surface runoff associated with this cultivation area was found entering the watercourse. See Cultivation Area B on the attached Mitigation Report.

At Site 12, windblown and discarded cultivation-related wastes are located along the entire southern edge of the cultivation area (Cultivation Area A), within the riparian setbacks of Blue Slide Creek.

At Site 13, a 500-gallon fuel tank and portable generator is located within the riparian setback of Blue Slide Creek. At this site there is also an unused fuel tank that is being stored on the ground and a 55-gallon drum of used motor oil.

At Site 24, a pile of uncontained bagged refuse is within the riparian area.

At Site 25, a bag of refuse was drug here and torn open by scavenging wildlife within riparian area.

At Site 26, legacy refuse and cultivation-related poly-pipe associated with an unused surface water diversion is located within the watercourse.

At Site 27, an enclosed cargo van is located within the riparian setbacks of a Class II watercourse.

At Site 28, two unused generators and a pile of potting soils are located within the riparian setbacks of a Class II watercourse.

At Site 29, cultivation-related poly-pipe associated with an unused surface water diversion is located within the watercourse.

Table 4: Riparian and Wetland Protection and Management

Disturbed Area	Disturbance Area Distances and Riparian Setbacks				Disturbed Area Within Setbacks [ft ²]
	Class I [Setback: 150']	Class II or Wetland [Setback: 100']	Class III [Setback: 50']	Perennial Spring [Setback: 150']	
Cultivation Area A	120' – 150'		20'		1,855
Cultivation Area B			40' – 45'		345
				Total =	3,460

Water Storage and Use

Project Compliance Y /N

All water on the property is derived from a permitted surface water diversion located on the property. At present there are no metering devices in place to record water usage associated with the irrigation of cannabis. A metering device shall be installed in 2019 to record all water used for the irrigation of cannabis. Monthly water usage shall be recorded for annual reporting purposes.

Water is stored in two 20,000-gallon bladders, two 5,000-gallon tanks, two 3,500 tanks, two 3,000-gallon tanks, and one 1,000-gallon tank. Fertilizer mixing occurs in two 1550-gallon tanks. Multiple water storage tanks were found to have lids not in place to prevent access and entrapment of wildlife. Tank lids shall be kept closed at all times when access is not needed. Tanks that do not utilize lids shall be retrofitted to be enclosed from wildlife. Overflow prevention measures be installed on diversion infrastructure or water storage tanks to prevent the overflowing of tanks and unnecessary diversion of water resources when water storage infrastructure has filled. Water conservation measures such as drip line irrigation, morning or evening watering, and mulch or cover cropping of cultivated top soils shall also be implemented.

Fertilizers, Pesticides, and Petroleum Products:

Project Compliance Y /N

Fertilizers, potting soils, compost, and other soils and soil amendments are currently stored on the property in a manner in which they can enter or be transported into surface waters and leached into groundwater. Cultivation areas are currently not maintained so as to prevent nutrients from leaving the site during the growing season and post-harvest.

At Site 11, used and unused fertilizer containers are being stored in an uncontained manner around a mixing tank.

At Site 30, new and used fertilizer containers are being stored in an uncontained manner around a mixing tank. This mixing tank and associated fertilizers are also located within the 50' riparian setbacks of a watercourse.

At Site 14, a soil pile is being stored where runoff from the pile is combining with concentrated road surface runoff and discharging into the head of a Class III watercourse at Site 15.

Fertilizers and soil amendments are applied and used per the manufacturer's guidelines. The use of pesticide products is consistent with product labeling and all products on the property are to be currently stored in closed structures to ensure that they do not enter or are released into surface or ground waters.

Currently, bulk fuel storage or petroleum products are present on the property.

At Site 13, a 500-gallon fuel tank is used to fuel an adjacent portable generator. This fuel tank and portable generator lacks a sealed secondary containment tub, sufficient cover to prevent any precipitation from entering the secondary containment, and is located within the riparian setback of Blue Slide Creek. At this site there is also an unused fuel tank that is being stored on the ground and a 55-gallon drum of used motor oil.

At Site 23, a 500-gallon fuel tank is used to fuel an adjacent portable generator. This fuel tank and portable generator lacks secondary containment and cover to prevent any precipitation from entering the secondary containment.

At Site 28, a 500-gallon tank was used to fuel a portable and fixed generator. This fuel tank and associated generators are no longer used and located within riparian setbacks.

Small quantities of fuel and motor oil are stored within fuel canisters, or the original oil containers, in various areas around the property without secondary containment. Any/all fuel canisters and motor oil containers shall be stored in secondary containment (e.g. plastic totes or sealed metal boxes) while being stored long term or not in immediate use, wherever these materials are used anywhere on the property.

Any/all future petroleum products and other liquid chemicals, including but not limited to diesel, biodiesel, gasoline, and oils shall be stored so as to prevent their spillage, discharge, or seepage into receiving waters. Storage tanks and containers shall be of suitable material and construction to be compatible with the substance(s) stored and conditions of storage such as pressure and temperature. Above ground storage tanks and containers shall be provided with a secondary means of containment for the entire capacity of the largest single container and sufficient cover shall be provided to prevent any/all precipitation from entering said secondary containment vessel. Cannabis cultivators shall ensure that diked areas are sufficiently impervious to contain discharged chemicals. Cannabis cultivators shall implement spill prevention, control, and countermeasures (SPCC) and have appropriate cleanup materials available onsite if the volume of a fuel container is greater than 1,320 gallons. Underground storage tanks 110 gallons and larger shall be registered with the appropriate County department and comply with state and local requirements for leak detection, spill overflow, corrosion protection, and insurance coverage. On site storage of petroleum products, or other fuels used for commercial activities may require registration as hazardous materials through the California Environmental Reporting System (CERS). Additionally, any waste oil generated from commercial activities (generators) is considered by the state hazardous waste and requires addition reporting. This cannabis cultivator is advised to contact local agencies to find out if such reporting is applicable to currently operations.

Cultivation-Related Wastes:

Project Compliance Y /N

The removal of cultivation-related wastes, spoils, and other related debris will lead to project compliance. See below. (Sites 12, 16, 17, 26, 27, 28, 29, and Cultivation Area A & B.)

Some cultivation-related wastes, including, but not limited to, empty soil/soil amendment/fertilizer/pesticide bags and containers, empty plant pots or containers, dead or harvested plant waste, and spent growth medium, are stored at locations where they can enter or be blown into surface waters, or in a manner that could result in residues and pollutants within such materials to migrate or leach into surface water or groundwaters.

At Site 12, windblown and discarded cultivation-related wastes are located along the entire southern edge of the cultivation area (Cultivation Area A), within the riparian setbacks of Blue Slide Creek.

At Site 16, a utility trailer full of cultivation-related wastes and refuse is being stored where winds, concentrated runoff, and scavenging wildlife is accessing the wastes and scattering the wastes.

At Site 17, cultivation-related wastes are being stored in an uncontained manner around this general area in an uncontained manner.

At Site 26, cultivation-related poly-pipe associated with an unused surface water diversion is located within the watercourse.

At Site 27, an enclosed cargo van is located within the riparian setbacks of a Class II watercourse.

At Site 28, two unused generators and a pile of potting soils are located within the riparian setbacks of a Class II watercourse.

At Site 29, cultivation-related poly-pipe associated with an unused surface water diversion is located within the watercourse.

Monofilament (e.g. plastic trellis netting and fencing) was observed on the property during the assessment. All monofilament netting or fencing is banned for future use. All existing monofilament netting shall be collected, secured with other refuse, and disposed of properly at a waste disposal facility.

Organic cultivation-related wastes are collected from the cultivation areas and either disposed of properly with general waste, or composted or burned. The cannabis cultivator shall ensure that the locations where organic wastes are stored, composted, or burned are minimized in number and are sited outside of watercourse riparian areas and away from any form of surface runoff.

Non-organic cultivation-related wastes shall be stored in lidded trashcans and garbage bags adjacent to or in the residence, sheds, and cultivation areas and shall be disposed of regularly at a solid waste transfer station. The cannabis cultivator shall continue to gather and properly dispose of cultivation-related wastes and ensure that wastes are adequately contained from scavenging wildlife, and cannot be transported away from storage areas by wind or surface runoff.

Refuse and Domestic Waste:

Project Compliance Y /N

Garbage and refuse are stored on the property within lidded trash cans and garbage bags and are disposed of regularly at the nearest solid waste transfer station. The cannabis cultivator shall continue to gather and properly dispose of refuse and ensure that refuse is adequately contained from scavenging wildlife, and cannot be transported away from storage areas by wind or surface runoff.

At Site 16, a utility trailer full of cultivation-related wastes and refuse is being stored where winds, concentrated runoff, and scavenging wildlife is accessing the wastes and scattering the wastes. At Site 24, a pile of uncontained bagged refuse is within the riparian area. At Site 25, a bag of refuse was drug here and torn open by scavenging wildlife within riparian area.

At Site 26, legacy refuse is located within the watercourse.

Human waste is managed by an outhouse structure on site. This outhouse does not appear to be a threat to water quality and the cultivator intends to discontinue use of the outhouse once appropriate facilities are installed. The cannabis cultivator intends to obtain a permitted onsite wastewater treatment system and portable chemical toilets as needed during the cultivation season. It is the cannabis cultivator's responsibility to ensure compliance of such action with the Humboldt County Department of Environmental Health and Human Services.

Annual Winterization Measures


Winterization measures consist of general cleanup and winter-preparation activities that both prepare for, and utilize, anticipated, local winter weather.

- Any exposed soils resulting from winterization activities shall be seeded and straw mulched.
- Any/all areas of exposed soils in and around cultivation areas shall be seeded and straw mulched.
- All existing culvert inlets, interiors, and outlets shall be cleared of any existing or potential obstructions to include; debris upstream of the culvert such as sediment, loose, moveable rocks, and raftable, small, woody debris.
- Damage or wear resulting from vehicular use to road surfaces (such as rutting or wheel tracks) and/or road surfacing (such as rock) that would impair road surface drainage or drainage features (such as outsloping, waterbars, rolling dips, etc.) shall be repaired prior to the Winter Period.
- All existing surface drainage features and sediment capture features shall be maintained if needed to ensure continued function through the Winter Period.
- All fertilizers and petroleum products will be stored in an area located outside of riparian setbacks, completely sealed, placed in a secondary containment (liquids), and stored in a manner that prevents contact with precipitation and surface runoff.
- Chemical toilets will be removed from the property until need resumes the following cultivation season, or at a minimum serviced and left unused during periods when not in use.
- Water storage tank lids shall be appropriately closed to prevent the access of wildlife.
- All refuse/trash shall be removed and disposed of appropriately.
- All inorganic material capable of being transported by wind or rain shall be secured and stored appropriately.

**STATEMENT OF CONTINGENT AND LIMITING CONDITIONS CONCERNING
THE PREPARATION AND USE OF REPORTS ADDRESSING GENERAL
WASTE DISCHARGE REQUIREMENTS UNDER ORDER WQ 2017-0023-DWQ**

Prepared by Timberland Resource Consultants

1. This document has been prepared for the property within APN 221-221-008, in Humboldt County, for enrollment in the General Waste Discharge Order WQ 2017-0023-DWQ.
2. Timberland Resource Consultants does not assume any liability for the use or misuse of the information in this document.
3. The information is based upon conditions apparent to Timberland Resource Consultants at the time inspection(s) were conducted. Changes due to land use activities or environmental factors occurring after inspection, have not been considered in this document.
4. Maps, photos, and any other graphical information presented in this report are for illustrative purposes. Their scales are approximate, and they are not to be used for locating and establishing boundary lines.
5. The conditions presented in this document may differ from those made by others or from changes on the property occurring after inspections were conducted. Timberland Resource Consultants does not guarantee this work against such differences.
6. Timberland Resource Consultants did not conduct an investigation on a legal survey of the property.
7. Persons using this document are advised to contact Timberland Resource Consultants prior to such use.
8. Timberland Resource Consultants will not discuss this document or reproduce it for anyone other than the Client for which this document was prepared without authorization from the Client.



Forrest Hansen

Timberland Resource Consultants








Timberland
Resource
Consultants







Treatment Implementation Schedule

Unique Point	Proposed Work Completion Date
Site 01	Prior to 10/15/20 pending the approval of any required permits
Site 02	Prior to 10/15/20 pending the approval of any required permits
Site 03	Prior to 10/15/20
Site 04	Prior to 10/15/20
Site 05	Prior to 10/15/20
Site 06	Prior to 10/15/20
Site 07	Prior to 10/15/20
Site 08	Prior to 10/15/20
Site 09	Prior to 10/15/20
Site 10	Prior to 10/15/20
Site 11	Immediately
Site 12	Immediately
Site 13	Immediately
Site 14	Immediately
Site 15	Immediately
Site 16	Immediately
Site 17	Immediately
Site 18	Prior to 10/15/20
Site 19	Prior to 10/15/21
Site 20	Immediately
Site 21	Prior to 10/15/21
Site 22	Immediately
Site 23	Immediately
Site 24	Immediately
Site 25	Immediately
Site 26	Immediately
Site 27	Immediately
Site 28	Immediately
Site 29	Immediately
Site 30	Immediately
Cultivation Area A	Immediately
Cultivation Area B	Immediately
Water Storage and Use	Immediately
POD	Immediately

Site Management Plan

Site Map [WDID - 1_12CC407765]

-  Property Boundary
-  Disturbed Area within Riparian Setbacks
-  Cultivation Area
-  Riparian Setback Area
-  Disturbed Area

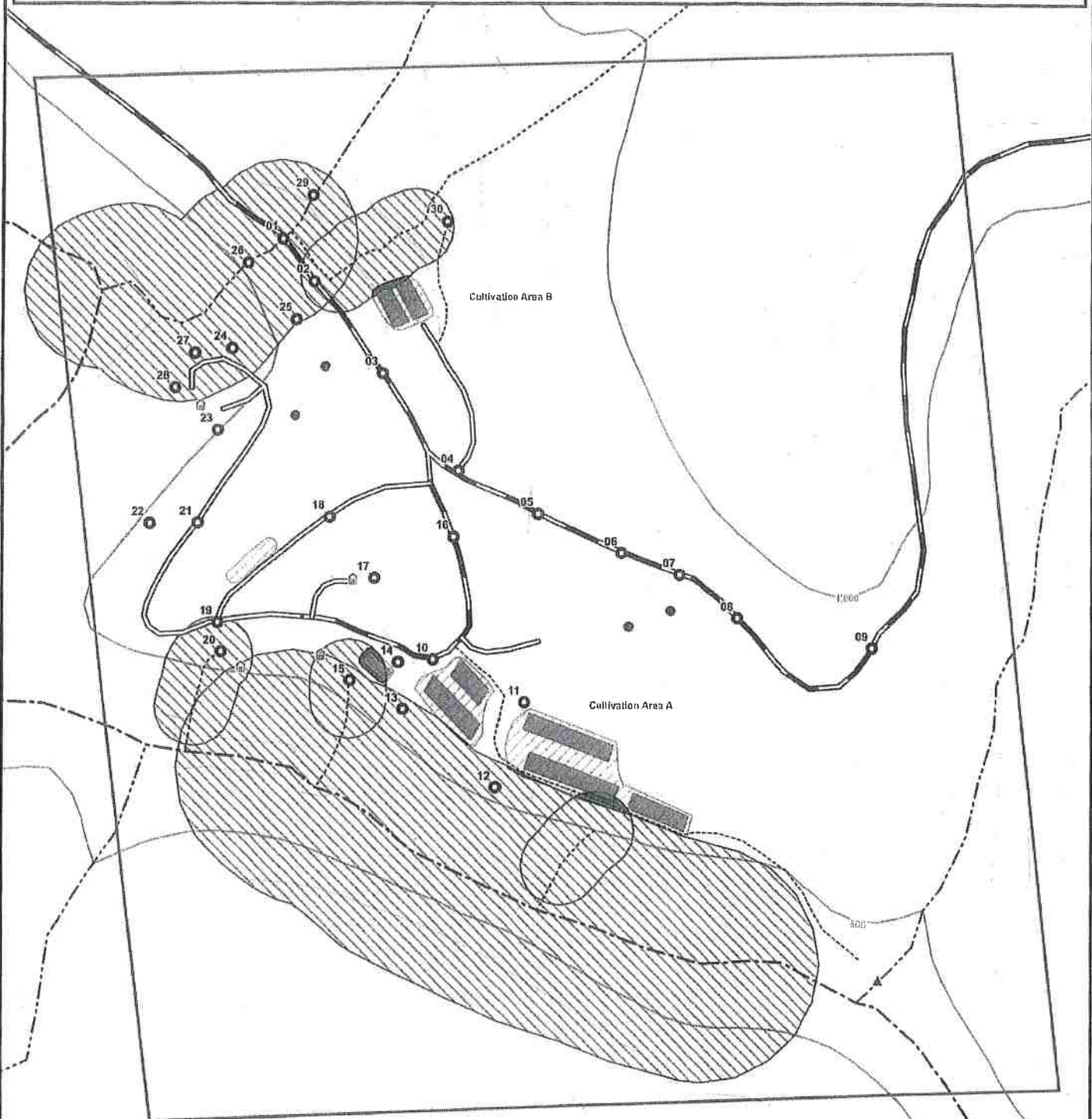
- Watercourses**
-  Class I
 -  Class II
 -  Class III
- Roads**
-  Permanent
 -  Seasonal Access
 -  Foot Trail

- Site**
-  Site
 -  POD
 -  Tank
 -  Bladder
 -  Structure








40' contour intervals
Map Date 4/5/2019




TRC - 430






Site Management Plan

Site Map [WDID - 1_12CC407765]

-  Property Boundary
-  Cultivation Area
-  Disturbed Area
-  Disturbed Area within Riparian Setbacks
-  Riparian Setback Area

- Watercourses
-  Class I
 -  Class II
 -  Class III

- Roads
-  Permanent
 -  Seasonal Access
 -  Foot Trail

-  Site
-  POD
-  Tank
-  Bladder
-  Structure



2016 NAIP DOQ
Map Date 4/5/2019

TRC - 430





SMP - Mitigation Report

WDID# - 1_12CC407765

Unique Point	Lat-Long NAD 83	Road Type	Mitigation Planned	Monitor	1600	Treatment Priority	Date Completed
Site 01	-123.961171 40.131731	Permanent	X	X	X	Prior to 10/15/20 pending the approval of any required permits	
<p>Current Condition: Class II watercourse crossing consisting of an 18-inch diameter corrugated metal pipe. The culvert is undersized, too short, not to grade, shotgunned, exposed in the road fill, and shows signs of overtopping. Concentrated road surface runoff from is also discharging into the watercourse via the inside ditch and outboard edge of the crossing. The outboard fillslope of the watercourse crossing is experiencing downcutting from the concentrated road surface runoff and from the Class III watercourse up grade that is jumping the inside ditch.</p>						<p>Prescribed Action: Upgrade the existing culvert with an 42" diameter culvert per attached BMPs: See Permanent Culvert Crossing, Permanent Culvert Crossing Design: Critical Dip and Hydrologic Disconnect Placement, Critical Dip, Culvert Orientation, Inlet and Outlet Armoring, General Operations BMPs, and General Erosion Control specifications.</p>	
Unique Point	Lat-Long NAD 83	Road Type	Mitigation Planned	Monitor	1600	Treatment Priority	Date Completed
Site 02	-123.961021 40.131584	Permanent	X	X	X	Prior to 10/15/20 pending the approval of any required permits	
<p>Current Condition: A Class III watercourse intercepts the road's inside ditch. There is no suitable location to re-align the watercourse into an original channel. There are signs of the watercourse jumping the shallow inside ditch onto the road surface and flows draining into the outlet of the watercourse crossing at Site 01, which is resulting in increased road surface erosion and the downcutting of the road's outboard fillslope at Site 01.</p>						<p>Prescribed Action: Install a rock-lined catchment basin where the Class III watercourse intercepts the inside ditch. This catchment basin shall be approximately 5' wide, as measured along the road shoulder, 4' deep, as measured in towards the cutbank, and approximately 3' deep and lined with clean 4" - 6" crushed angular rock. The inside ditch from the catchment basin to the inlet of the culvert at Site 01 shall be excavated and rock lined. The inside ditch shall be excavated to approximately 3' wide and 3' deep and rock-lined with clean 4" - 6" crushed angular rock.</p>	
Unique Point	Lat-Long NAD 83	Road Type	Mitigation Planned	Monitor	1600	Treatment Priority	Date Completed
Site 03	-123.960694 40.131266	Permanent	X	X	-	Prior to 10/15/20	
<p>Current Condition: A long, undrained, inside ditch is discharging into a Class III and Class II watercourse down grade.</p>						<p>Prescribed Action: Install an 18" diameter ditch relief culvert that drains into the swale downslope, behind the fence, per attached BMPs: See Ditch Relief Culvert, and Permanent Culvert Crossing Design (Inlet and Outlet Armoring), General Operations BMPs, and General Erosion Control specifications.</p>	
Unique Point	Lat-Long NAD 83	Road Type	Mitigation Planned	Monitor	1600	Treatment Priority	Date Completed
Site 04	-123.960335 40.130929	Seasonal	X	X	-	Prior to 10/15/20	
<p>Current Condition: Inside ditch crossing consisting of a 15-inch diameter corrugated plastic pipe. The culvert crossing is plugging and too short, resulting in road surface runoff from the steep, unsurfaced, encroachment road discharging into the inside ditch and watercourses down grade.</p>						<p>Prescribed Action: Upgrade the existing culvert with an 18" diameter by 40' long culvert. Clear the inside ditch up grade to Site 05 and down grade to Site 03. Rock surface the encroachment road with crushed angular rock.</p>	



Timberland
Resource
Consultants

SMP - Mitigation Report

WDID# - 1_12CC407765

Unique Point	Lat-Long NAD 83	Road Type	Mitigation Planned	Monitor	1600	Treatment Priority	Date Completed
Site 05	-123.959961 40.130781	Permanent	X	X		Prior to 10/15/20	
<p>Current Condition: Concentrated road surface runoff and a long, undrained, inside ditch is discharging into the watercourse at Site 02, the watercourse crossing at Site 01, and the head of a watercourse at Site 15.</p>						<p>Prescribed Action: Install a Type 1 rocked rolling dip in combination with an 18-inch ditch relief culvert per attached BMPs: See Waterbar/Rolling Dip Combined with DRC, Ditch Relief Culvert, Rolling Dip Design and Placement, Rocked Rolling Dip Design and Placement, General Operations BMPs, and General Erosion Control specifications. Install the rolling dip down grade of the ditch relief culvert. Rock armor the inlet and outlet per attached BMPs: See Permanent Culvert Crossing Design (Inlet and Outlet Rock Armoring) specifications. Install a series of three staked wattles at the outflow of the culvert spaced approximately 3' - 5' apart, per attached specifications.</p>	
Site 06	-123.959573 40.130648	Permanent	X	X	-	Prior to 10/15/20	
<p>Current Condition: The road surface is severely rutted for approximately 200 feet. The inside ditch up grade at Site 07 has filled with debris resulting in flows jumping the ditch onto the road, resulting in road saturation. The inside ditch from Site 05 to Site 08 is filling with the soft road shoulder and other debris. This site discharges into watercourses down grade at Site 01, 02, and 15.</p>						<p>Prescribed Action: Clear the inside ditch from Site 05 to Site 08. Re-grade the road and rock surface the road for approximately 200' with crushed angular where rutting is occurring.</p>	
Site 07	-123.959301 40.130574	Permanent	X	X	-	Prior to 10/15/20	
<p>Current Condition: The inside ditch has become filled with the soft shoulder of the road and debris, resulting it diverting onto the road surface.</p>						<p>Prescribed Action: Clear the inside ditch from Site 05 to Site 08.</p>	
Site 08	-123.959028 40.130425	Permanent	X	X	-	Prior to 10/15/20	
<p>Current Condition: Concentrated road surface runoff is contributing to road surface erosion and sediment discharge into watercourses down grade. ins type 1 rolling dip before through cut</p>						<p>Prescribed Action: Install a Type 1 rocked rolling dip before the through cut begins per attached BMPs: See Rolling Dip Design and Placement, Rocked Rolling Dip Design and Placement, General Operations BMPs, and General Erosion Control specifications.</p>	
Site 09	-123.958406 40.130325	Permanent	X	X	-	Prior to 10/15/20	
<p>Current Condition: Long, undrained, inside ditch contributing to road surface erosion and sediment discharge into watercourses down grade.</p>						<p>Prescribed Action: Install an 18" diameter ditch relief culvert per attached BMPs: See Ditch Relief Culvert, and Permanent Culvert Crossing Design (Inlet and Outlet Armoring), General Operations BMPs, and General Erosion Control specifications.</p>	



Timberland
Resource
Consultants

SMP - Mitigation Report

WDID# - 1_12CC407765

Unique Point	Lat-Long NAD 83	Road Type	Mitigation Planned	Monitor	1600	Treatment Priority	Date Completed
Site 10	-123.960438 40.130268	Permanent	X	X	-	Prior to 10/15/20	
<p>Current Condition: Concentrated road surface runoff, addressed via Sites 05, 06, 07, 08, & 09, is contributing to road surface erosion (Site 15 to Site 10 to Site 16) and sediment discharge into watercourses down grade (Site 15).</p>						<p>Prescribed Action: Rock surface the access road from the property entrance gate to Site 15 and around the general parking area and driveway around the permanent structures adjacent to Site 15. See the "Permanent Road" entrance road on attached Site Maps.</p>	
Unique Point	Lat-Long NAD 83	Road Type	Mitigation Planned	Monitor	1600	Treatment Priority	Date Completed
Site 11	-123.96001 40.130123	-	X	X	-	Immediately	
<p>Current Condition: Fertilizer mixing tank with numerous used and unused fertilizer jugs and buckets uncontained and discarded around the tank.</p>						<p>Prescribed Action: Obtain a securable fertilizer storage structure that provides secondary containment, protects the stored fertilizers from scavenging wildlife and precipitation. Obtain absorbent materials designated for spill containment and spill cleanup equipment on-site for use in an accidental spill of fertilizers. Gather and properly dispose of all refuse and cultivation-related wastes around the mixing tank.</p>	
Unique Point	Lat-Long NAD 83	Road Type	Mitigation Planned	Monitor	1600	Treatment Priority	Date Completed
Site 12	-123.960141 40.129826	-	X	X	-	Immediately	
<p>Current Condition: Windblown and discarded refuse and cultivation-related wastes are along the entire southern edge of Cultivation Area A, within the riparian setback area of Blue Slide Creek.</p>						<p>Prescribed Action: Gather and properly dispose of all refuse and cultivation-related wastes along the entire southern edge of Cultivation Area A and within the riparian setbacks of Blue Slide Creek. Secure and contain all future generated refuse and cultivation-related wastes to prevent their transportation by either wind, surface runoff, or scavenging wildlife by the installation of lidded trashcans with trash bags at all greenhouses. Dispose of wastes regularly to prevent their buildup. Any wastes that cannot be contained by lidded trashcan shall be immediately removed and contained elsewhere in an appropriate container. (E.g. dumpster, covered utility trailer, covered truck)</p>	
Unique Point	Lat-Long NAD 83	Road Type	Mitigation Planned	Monitor	1600	Treatment Priority	Date Completed
Site 13	-123.960575 40.130094	-	X	X	-	Immediately	
<p>Current Condition: A 500-gallon fuel tank is used to fuel an adjacent portable generator. This fuel tank and portable generator lacks a sealed secondary containment tub, sufficient cover to prevent any precipitation from entering the secondary containment, and is located within the riparian setback of Blue Slide Creek. At this site there is also an unused fuel tank that is being stored on the ground and a 55-gallon drum of used motor oil.</p>						<p>Prescribed Action: Relocate the generator and in-use fuel tank outside of any watercourse riparian setback. Install the drain plug on the 500-gallon fuel tanks secondary containment tub. Install secondary containment on the portable generator and cover over both the generator and in-use fuel tank to prevent precipitation from filling the secondary containment of either the fuel tank or generator. Remove the 55-gallon drum of used motor oil from riparian setbacks and transfer the used motor oil to the appropriate disposal center. Remove the unused fuel tank from riparian setbacks.</p>	



Timberland
Resource
Consultants

SMP - Mitigation Report

WDID# - 1_12CC407765

Unique Point	Lat-Long NAD 83	Road Type	Mitigation Planned	Monitor	1600	Treatment Priority	Date Completed
Site 14	-123.9606 40.130258	-	X	X	-	Immediately	
<p>Current Condition: Uncontained soil pile located where surface runoff is transporting soils and fertilizer runoff into the head of a Class III watercourse at Site 15.</p>						<p>Prescribed Action: Relocate all of the soil pile, as feasible, to the soil pile located adjacent to Site 11, approximately 200' to the east by the other greenhouse at Cultivation Area A. Discontinue storing soils at this location. Seed and mulch with weed free straw all remnant soils or exposed ground from the removal of the soil pile. All soil piles shall be covered with weighed down tarps and staked wattles installed around the perimeter of the pile prior to the winter period, annually.</p>	
Unique Point	Lat-Long NAD 83	Road Type	Mitigation Planned	Monitor	1600	Treatment Priority	Date Completed
Site 15	-123.96079 40.130238	-	X	X	-	Immediately	
<p>Current Condition: Concentrated road surface runoff is discharging into the head of a Class III watercourse. The concentrated road surface runoff will be addressed via Sites 05, 06, 07, 08, 09, & 10. A nursery greenhouse is located within the riparian setbacks at this location as well.</p>						<p>Prescribed Action: Remove the nursery greenhouse and discontinue use of this location for cultivation-related activities. Seed and mulch with weed free straw all bare ground soils within the flagged, 50', riparian setback area. Install staked wattles along the upper bank edges of the Class III watercourse, as flagged in the field, per attached specifications.</p>	
Unique Point	Lat-Long NAD 83	Road Type	Mitigation Planned	Monitor	1600	Treatment Priority	Date Completed
Site 16	-123.960352 40.130698	-	X	X	-	Immediately	
<p>Current Condition: Utility trailer overflowing with refuse and cultivation-related wastes. Scavenging wildlife is scattering the refuse where concentrated road surface runoff is transporting this refuse towards surface waters at Site 15.</p>						<p>Prescribed Action: Gather and properly secure and contain all refuse and cultivation-related wastes in the trailer. Dispose of stored wastes regularly and before the winter period.</p>	
Unique Point	Lat-Long NAD 83	Road Type	Mitigation Planned	Monitor	1600	Treatment Priority	Date Completed
Site 17	-123.960717 40.130551	-	X	X	-	Immediately	
<p>Current Condition: Uncontained refuse and cultivation-related waste are stored and haphazardly discarded around this general area of approximately 100' in all directions.</p>						<p>Prescribed Action: Gather and properly secure and contain all refuse, cultivation-related wastes, and materials within this general area (100' in all directions) in lidded trashcans with trash bags or within adjacent structures. Any wastes that cannot be contained by lidded trashcan shall be immediately removed and contained elsewhere in an appropriate container. (E.g. dumpster, covered utility trailer, covered truck)</p>	



Timberland
Resource
Consultants

SMP - Mitigation Report

WDID# - 1_12CC407765

Unique Point	Lat-Long NAD 83	Road Type	Mitigation Planned	Monitor	1600	Treatment Priority	Date Completed
Site 18	-123.96093 40.130763	Seasonal	X	X	-	Prior to 10/15/20	
<p>Current Condition: Concentrated road surface runoff is eroding the road surface here and contributing to further road surface erosion, rutting of the road surface at Site 19, and transportation of cultivation-related soils and sediment into the head of a Class III watercourse at Site 20.</p>						<p>Prescribed Action: Install a Type 1 rocked rolling dip that drains road surface runoff to the west per attached BMPs: See Rolling Dip Design and Placement, Rocked Rolling Dip Design and Placement, General Operations BMPs, and General Erosion Control specifications.</p>	
Unique Point	Lat-Long NAD 83	Road Type	Mitigation Planned	Monitor	1600	Treatment Priority	Date Completed
Site 19	-123.961444 40.130391	Seasonal	X	X	-	Prior to 10/15/21	
<p>Current Condition: Concentrated road surface runoff and runoff from the decommissioned cultivation/conversion area to the north is eroding the road surface, saturating the road surface which is allowing ruts to form, and transporting sediment and cultivation soils into the head of a Class III watercourse at Site 20.</p>						<p>Prescribed Action: Re-grade the road surface 30' in all directions from the road intersection to remove ruts. Rock surface the road surface 30' in all directions from the road intersection.</p>	
Unique Point	Lat-Long NAD 83	Road Type	Mitigation Planned	Monitor	1600	Treatment Priority	Date Completed
Site 20	-123.961426 40.130288	-	X	X	-	Immediately	
<p>Current Condition: Concentrated road surface runoff and runoff from a previous cultivation area is discharging into the head of a Class III watercourse. Cultivation-related wastes and refuse is located within and around the watercourse as well.</p>						<p>Prescribed Action: Remove and properly dispose of all cultivation-related wastes and refuse from the head of the watercourse and the 50' riparian setbacks. Discontinue the storage of any refuse or cultivation-related materials from this location. Seed and mulch with weed free straw all bare ground soils within the flagged, 50', riparian setback area. Install three bands of staked wattle above the head of the watercourse at an approximately 5' spacing, as flagged in the field, per attached specifications.</p>	
Unique Point	Lat-Long NAD 83	Road Type	Mitigation Planned	Monitor	1600	Treatment Priority	Date Completed
Site 21	-123.961544 40.130738	Seasonal	X	X	-	Prior to 10/15/21	
<p>Current Condition: Concentrated road surface runoff is eroding the road surface.</p>						<p>Prescribed Action: Install a Type 1 rocked rolling dip per attached BMPs: See Rolling Dip Design and Placement, Rocked Rolling Dip Design and Placement, General Operations BMPs, and General Erosion Control specifications.</p>	



SMP - Mitigation Report

WDID# - 1_12CC407765

Unique Point	Lat-Long NAD 83	Road Type	Mitigation Planned	Monitor	1600	Treatment Priority	Date Completed
Site 22	-123.961763 40.130735	-	X	X	-	Immediately	
<p>Current Condition: Two 20,000-gallon bladders being used without a secondary containment system.</p>						<p>Prescribed Action: Install a secondary containment system for both bladders. Per Cannabis Cultivation Policy: Attachment A, Section 2, No. 88 & 89 for cannabis cultivators, bladders shall be safely contained within a secondary containment system with sufficient capacity to capture 110 percent of a bladders maximum volume in the event of bladder failure and if open to rainfall, and/or (whichever is larger) capable to accommodate precipitation and storm water inputs from 24 hours of a 25-year storm event. Secondary containment is recommended in the form of a dirt berm, containment pit, combination of both, or impermeable material with skeletal support.</p>	
Unique Point	Lat-Long NAD 83	Road Type	Mitigation Planned	Monitor	1600	Treatment Priority	Date Completed
Site 23	-123.961458 40.131063	-	X	X	-	Immediately	
<p>Current Condition: A 500-gallon fuel tank is used to fuel an adjacent portable generator. The portable generator has been removed at the time of the assessment. The fuel tank is being stored on the ground. The fuel tank and portable generator lacks a sealed secondary containment tub and sufficient cover to prevent any precipitation from entering the secondary containment.</p>						<p>Prescribed Action: Install secondary containment on the generator and portable generator. Install cover over both the generator and fuel tank to prevent precipitation from filling the secondary containment of either the fuel tank or generator.</p>	
Unique Point	Lat-Long NAD 83	Road Type	Mitigation Planned	Monitor	1600	Treatment Priority	Date Completed
Site 24	-123.961399 40.131348	-	X	X	-	Immediately	
<p>Current Condition: Pile of bagged refuse within riparian area.</p>						<p>Prescribed Action: Gather and properly dispose of all the bagged refuse stored at this location. In the future, secure and contain all refuse and cultivation-related wastes. Dispose of stored wastes regularly and before the winter period. Secure and contain all future generated refuse and cultivation-related wastes to prevent their transportation by either wind, surface runoff, or scavenging wildlife.</p>	
Unique Point	Lat-Long NAD 83	Road Type	Mitigation Planned	Monitor	1600	Treatment Priority	Date Completed
Site 25	-123.9611 40.131451	-	X	X	-	Immediately	
<p>Current Condition: Bag of refuse drug here and torn open by scavenging wildlife, within riparian area.</p>						<p>Prescribed Action: Gather and properly dispose of all scattered refuse at this location. Secure and contain all future generated refuse and cultivation-related wastes to prevent their transportation by either wind, surface runoff, or scavenging wildlife.</p>	



Timberland
Resource
Consultants

SMP - Mitigation Report

WDID# - 1_12CC407765

Unique Point	Lat-Long NAD 83	Road Type	Mitigation Planned	Monitor	1600	Treatment Priority	Date Completed
Site 26	-123.961331 40.131646	-	X	X	-	Immediately	
Current Condition: Legacy refuse and cultivation-related poly-pipe within the watercourse.						Prescribed Action: Gather and properly dispose of all legacy refuse and cultivation-related poly-pipe from the watercourse.	
Unique Point	Lat-Long NAD 83	Road Type	Mitigation Planned	Monitor	1600	Treatment Priority	Date Completed
Site 27	-123.96157 40.131331	-	X	X	-	Immediately	
Current Condition: Vehicle and disposed cultivation-related soils located within the riparian setback of a Class II watercourse.						Prescribed Action: Remove the disposed cultivation-related soils and vehicle from the 100' riparian setback of the adjacent Class II watercourse.	
Unique Point	Lat-Long NAD 83	Road Type	Mitigation Planned	Monitor	1600	Treatment Priority	Date Completed
Site 28	-123.961658 40.13121	-	X	X	-	Immediately	
Current Condition: A 500-gallon tank was used to fuel a portable and fixed generator. This fuel tank and associated generators are no longer used and located within riparian setbacks.						Prescribed Action: Remove the fuel tank and associated generators from the riparian setbacks of the adjacent Class II watercourse.	
Unique Point	Lat-Long NAD 83	Road Type	Mitigation Planned	Monitor	1600	Treatment Priority	Date Completed
Site 29	-123.961033 40.131884	-	X	X	-	Immediately	
Current Condition: An unused point of diversion and associated poly-pipe have been left in the watercourse.						Prescribed Action: Remove the point of diversion at the head of the watercourse and remove all associated poly-pipe left in the watercourse.	
Unique Point	Lat-Long NAD 83	Road Type	Mitigation Planned	Monitor	1600	Treatment Priority	Date Completed
Site 30	-123.960405 40.131797	-	X	X	-	Immediately	
Current Condition: Fertilizer mixing tank and fertilizers containers are located within riparian setbacks.						Prescribed Action: Relocated the mixing tank outside of the 50' riparian setbacks. Obtain a securable fertilizer storage structure that provides secondary containment, protects the stored fertilizers from scavenging wildlife and precipitation. Obtain absorbent materials designated for spill containment and spill cleanup equipment on-site for use in an accidental spill of fertilizers. Gather and properly dispose of all refuse and cultivation-related wastes around the mixing tank.	



Timberland
Resource
Consultants

SMP - Mitigation Report

WDID# - 1_12CC407765

Unique Point	Lat-Long NAD 83	Road Type	Mitigation Planned	Monitor	1600	Treatment Priority	Date Completed
Cultivation Area A	N/A	-	X	X	-	Immediately	
<p>Current Condition: Cultivation Area, and associated Disturbed Area, is located within the riparian setbacks of Blue Slide Creek (Class I - 150') and two Class III watercourses (Class III). Also, cultivation-related wastes and refuse has been discarded and left uncontained around the cultivation area where it can enter surface waters.</p>						<p>Prescribed Action: Remove the nursery greenhouse adjacent to Site 14. Seed with grass and mulch the greenhouse footprint and area around it with weed free straw. Remove the sections of 120' greenhouse located within the riparian setbacks of the Class III watercourse. Install staked wattles along the downslope edges of the greenhouse flats, along the entire edge of the cultivation area that borders the riparian setback area of Blue Slide Creek. Do not store or dispose of any materials within the riparian setback area along the entire cultivation area. Gather and properly dispose of all refuse and cultivation-related wastes around the entire cultivation area and within the riparian setbacks of Blue Slide Creek. Secure and contain all future generated refuse and cultivation-related wastes to prevent their transportation by either wind, surface runoff, or scavenging wildlife by the installation of lidded trashcans with trash bags at all greenhouses. Dispose of wastes regularly to prevent their buildup. Any wastes that cannot be contained by lidded trashcan shall be immediately removed and contained elsewhere in an appropriate container. (E.g. dumpster, covered utility trailer, covered truck)</p>	
Unique Point	Lat-Long NAD 83	Road Type	Mitigation Planned	Monitor	1600	Treatment Priority	Date Completed
Cultivation Area B	N/A	-	X	X	-	Immediately	
<p>Current Condition: Cultivation-related wastes and refuse has been discarded and left uncontained around the cultivation area where it can enter surface waters.</p>						<p>Prescribed Action: Remove both of the greenhouses located within the riparian setbacks, as shown on the attached site map. Gather and properly dispose of all refuse and cultivation-related wastes around the entire cultivation area and within the riparian setbacks of the adjacent Class III watercourse. Secure and contain all future generated refuse and cultivation-related wastes to prevent their transportation by either wind, surface runoff, or scavenging wildlife by the installation of lidded trashcans with trash bags at all greenhouses. Dispose of wastes regularly to prevent their buildup. Any wastes that cannot be contained by lidded trashcan shall be immediately removed and contained elsewhere in an appropriate container. (E.g. dumpster, covered utility trailer, covered truck)</p>	
Unique Point	Lat-Long NAD 83	Road Type	Mitigation Planned	Monitor	1600	Treatment Priority	Date Completed
Water Storage and Use	N/A	-	X	X	-	Immediately	
<p>Current Condition: At present there are no devices or procedures in place to record water usage associated with the irrigation of cannabis.</p>						<p>Prescribed Action: A means to monitor water usage shall be used yearly starting in 2019 to record all water used for the irrigation of cannabis. Monthly water usage shall be recorded for annual reporting purposes.</p>	



SMP - Mitigation Report

WDID# - 1_12CC407765

Unique Point	Lat-Long NAD 83	Road Type	Mitigation Planned	Monitor	1600	Treatment Priority	Date Completed
POD	-123.958354 40.129168	-	X	-X	-	Immediately	
<p>Current Condition: While the Point of Diversion(POD) is in use a portable gas-powered pump is used within the 150' riparian setbacks of Blue Slide Creek.</p>						<p>Prescribed Action: All gas or diesel powered pumps or generators shall not be located within riparian setbacks. All water storage tanks, bladders, and other off-stream water storage facilities shall not be located within riparian setbacks.</p>	

BMP: Winterization and Interim Treatments for Erosion Control

• Roads

- Existing or newly installed road surface drainage structures such as water bars, rolling dips, ditch relief culverts, and intentionally in/out-sloped segments of road shall be maintained to ensure continued function of capturing and draining surface runoff.
- Hand tool kick-outs (lead out ditch) for existing wheel rut, surface run-off confinement.
- Temporary waterbar/cross-wattles installed on road/trail sections of concentrating surface runoff.
- Clean existing ditch relief culvert inlets, outlets, and contributing ditch lines of current and potential blockage debris by hand.
- Hand place energy dissipating rock/small woody debris at ditch relief culvert outlets where erosion is occurring.
- Wattles/straw bales placed at road runoff delivery sites.
- Touch-up with hand tools of existing surface drainage structures (kick-outs, rolling dips, and waterbars).
- Seed and straw un-used, or to be abandoned, road surfaces where erosion is occurring.
- Frequent use of un-surfaced roads should be avoided, particularly when road surfaces are soft/saturated.

• Crossings

- Clean inlets, outlets, and channels above of current and potential blockage debris by hand.
- Hand place energy dissipating rock/small woody debris at ditch relief culvert outlets.
- Hand placement of rock armor around culvert inlets.
- Install staked wattles along the outboard road edge of out-sloped watercourse crossings where direct delivery of road surface runoff is occurring.
- Hand placement of rock on crossing fill faces where erosion is/may occur as a result of poor crossing construction.

• Cultivation Areas

- Use hand tools to capture cultivation related soils that are not contained (soil from post-harvest plant removal, soil/planter removal, general spillage).
- Treat beds, pots, new soil storage piles, spent soil piles, and soil disposal piles with cover crops for soil stability and potentially nitrogen fixing/soil amendment.
- Bagged potting soil should be covered.
- Install staked wattles or an earthen berm around cultivation soils piles prior to the winter period, annually.
- Any soil amendment, fertilizer, herbicide, or pesticide that is not 100% sealed should be stored under cover.
- Cultivation sites with poor or concentrating drainage can have wattles or bales installed prior to winter to help prevent sediment and nutrients from leaving the site.
- Plastic netting shall be disposed of or stored where it is inaccessible to wildlife.
- Tarps/dep covers shall be stored so they cannot be blown away.
- General waste from growing season gathered up and disposed of.
- Exposed soil surfaces in the cultivation area, as well as graded fill slopes should be seeded, strawed, mulched, jute netted as needed.

• General Areas

- Remove all refuse prior to leaving property for the season.
- Back fill pit toilets to be abandoned.

BMP: General Recommendations

- **Fertilizers, soil amendments, and pesticides**
 - Fertilizer, soil amendments, and pesticide use it to be recorded in such a manner that cumulative annual totals are recorded for annual reporting.
 - Store in-use fertilizers in a securable storage container, such as a tote or deck box, adjacent to the mixing tanks.

- **Petroleum products and hazardous materials**
 - Utilize spill trays/containment structures and cover over the containment when using, fueling, changing oil on portable generators or petroleum powered water pumps to prevent the potential for leeching, seepage or spillage of petroleum products.
 - It is recommended that all petroleum products and other chemicals are registered with the California Environmental Reporting System (CERS) to satisfy future licensing requirements.

- **Water storage and Use**
 - Water use shall be designed and metered such that water used for the irrigation of cannabis will be recorded separately from domestic use. Water use for the irrigation of cannabis is to be recorded monthly for annual reporting.
 - Ensure lids are secured on all water storage tanks to prevent wildlife from becoming entrapped within the tank.
 - Install float valves, or implement another equivalent system, on all applicable water storage and transfer tanks to prevent unnecessary water diversion and the overflowing of water tanks.

BMP: General Operations BMPs

- If operations require moving of equipment across a flowing stream, such operations shall be conducted without causing a prolonged visible increase in stream turbidity. For repeated crossings, the operator shall install a bridge, culvert, or rock-lined crossing.
- During construction in flowing water, which can transport sediment downstream, the flow shall be diverted around the work area by pipe, pumping, temporary diversion channel or other suitable means. When any dam or artificial obstruction is being constructed, maintained, or placed in operation, sufficient water shall at all times be allowed to pass downstream to maintain fish life below the dam. Equipment may be operated in the channel of flowing live streams only as necessary to construct the described construction.
- Disturbance or removal of vegetation shall not exceed the minimum necessary to complete operations. The disturbed portion of any stream channel shall be restored to as near their original condition as possible. Restoration shall include the mulching of stripped or exposed dirt areas at crossing sites prior to the end of the work period.
- Structures and associated materials not designed to withstand high seasonal flow shall be removed to areas above the high-water mark before such flows occur.
- No debris, soil, silt, sand, bark, slash, sawdust, rubbish, cement or concrete washing, oil or petroleum products, or other organic or earthen material from any logging, construction, or associated activity of whatever nature shall be allowed to enter into or be placed where it may be washed by rainfall or runoff into waters of the State. When operations are completed, any excess materials or debris shall be removed from the work area. No rubbish shall be deposited within 150 feet of the high-water mark of any stream.

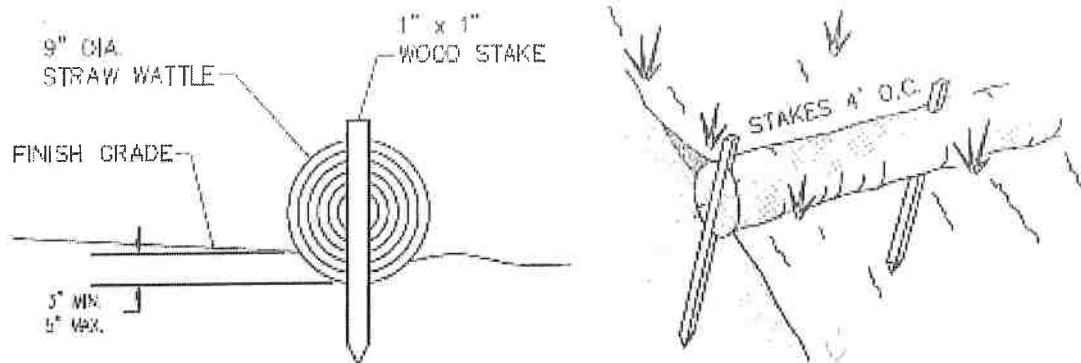
BMP: General Erosion Control

- Timing for soil stabilization measures within the 100 feet of a watercourse or lake: For areas disturbed from May 1 through October 15, treatment shall be completed prior to the start of any rain that causes overland flow across or along the disturbed surface. For areas disturbed from October 16 through April 30, treatment shall be completed prior to any day for which a chance of rain of 30 percent or greater is forecast by the National Weather Service or within 10 days, whichever is earlier.
- Within 100 feet of a watercourse or lake, the traveled surface of logging roads shall be treated to prevent waterborne transport of sediment and concentration of runoff that results from operations. Treatment may consist of, but not limited to, rocking, out sloping, rolling dips, cross drains, water bars, slope stabilization measures, or other practices appropriate to site-specific conditions.
- The treatment for other disturbed areas within 100 feet of a watercourse or lake, including: (A) areas exceeding 100 contiguous square feet where operations have exposed bare soil, (B) approaches to road watercourse crossings out to 100 feet or the nearest drainage facility, whichever is farthest, (C) road cut banks and fills, and (D) any other area of disturbed soil that threatens to discharge sediment into waters in amounts deleterious to the quality and beneficial uses of water, shall be grass seeded and mulched with straw or fine slash. Grass seed shall be applied at a rate exceeding 100 pounds per acre. Straw mulch shall be applied in amounts sufficient to provide at least 2- 4-inch depth of straw with minimum 90% coverage. Slash may be substituted for straw mulch provided the depth, texture, and ground contact are equivalent to at least 2 – 4 inches of straw mulch. Any treated area that has been subject to reuse or has less than 90% surface cover shall be treated again prior to the end of operations.
- Within 100 feet of a watercourse or lake, where the undisturbed natural ground cover cannot effectively protect beneficial uses of water from operations, the ground shall be treated with slope stabilization measures described in #3 above per timing described in #1 above.
- Side cast or fill material extending more than 20 feet in slope distance from the outside edge of a landing which has access to a watercourse or lake shall be treated with slope stabilization measures described in #3 above. Timing shall occur per #1 above unless outside 100 feet of a watercourse or lake, in which completion date is October 15.
- All roads shall have drainage and/or drainage collection and storage facilities installed as soon as practical following operations and prior to either (1) the start of any rain which causes overland flow across or along the disturbed surface within 100 feet of a watercourse or lake protection, or (2) any day with a National Weather Service forecast of a chance of rain of 30 percent or more, a flash flood warning, or a flash flood watch.

BMP: General Erosion Control (Cont.)

- Erosion control and sediment detention devices and materials shall be incorporated into the cleanup/restoration work design and installed prior to the end of project work and before the beginning of the rainy season. Any continuing, approved project work conducted after October 15 shall have erosion control works completed up-to-date and daily.
- Erosion control materials shall be, at minimum, stored on-site at all times during approved project work between May 1 and October 15.
- Approved project work within the 5-year flood plain shall not begin until all temporary erosion controls (straw bales or silt fences that are effectively keyed-in) are installed downslope of cleanup/restoration activities.
- Non-invasive, non-persistent grass species (e.g., barley grass) may be used for their temporary erosion control benefits to stabilize disturbed slopes and prevent exposure of disturbed soils to rainfall.
- Upon work completion, all exposed soil present in and around the cleanup/restoration sites shall be stabilized within 7 days.
- Soils exposed by cleanup/restoration operations shall be seeded and mulched to prevent sediment runoff and transport.
- Straw Wattles (if used) shall be installed with 18 or 24-inch wood stakes at four feet on center. The ends of adjacent straw wattles shall be abutted to each other snugly or overlapped by six inches. Wattles shall be installed so that the wattle is in firm contact with the ground surface.

BMP: General Erosion Control (Cont.)

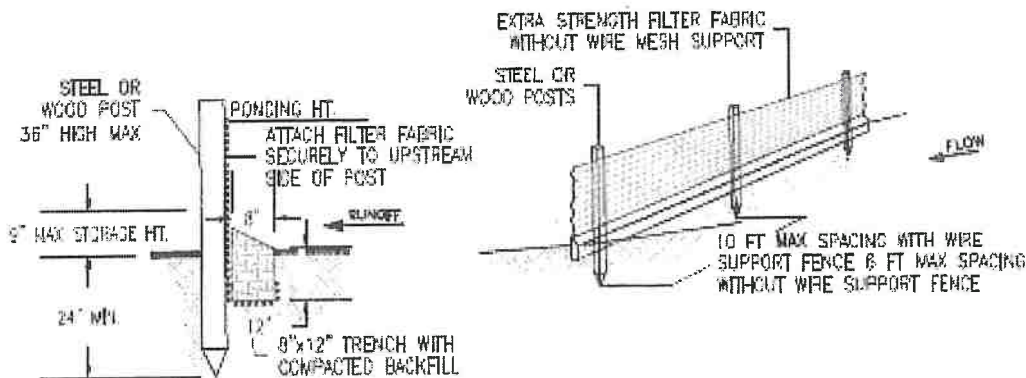


STRAW WATTLE NOTES:

1. STRAW WATTLES SHALL BE INSTALLED WITH 18 OR 24 INCH WOOD STAKES AT FOUR FEET ON CENTER. THE ENDS OF ADJACENT STRAW WATTLES SHALL BE ADJUTED TO EACH OTHER SINGLY OR OVERLAPPED BY SIX INCHES.
2. STRAW ROLL INSTALLATION REQUIRES THE PLACEMENT AND SECURE STAKING OF THE ROLL IN A TRENCH. 3"-5" DEEP. RUNOFF MUST NOT BE ALLOWED TO RUN UNDER OR AROUND THE ROLL.

STRAW WATTLE INSTALLATION DETAIL

NTS



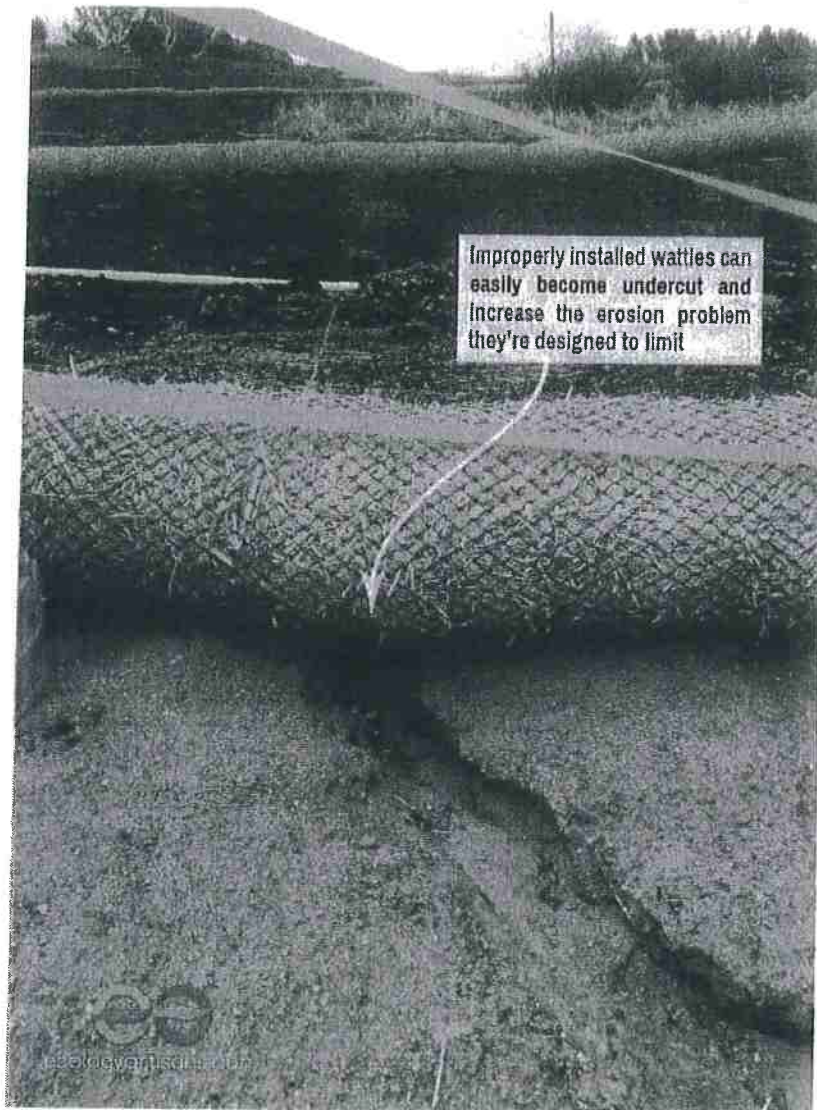
SILT FENCE NOTES:

1. THE CONTRACTOR SHALL INSPECT AND REPAIR FENCE AFTER EACH STORM EVENT
2. CONTRACTOR SHALL REMOVE SEDIMENT AS NECESSARY. REMOVED SEDIMENT SHALL BE DEPOSITED TO AN AREA THAT WILL NOT CONTRIBUTE SEDIMENT OFF-SITE AND IN AN AREA THAT CAN BE PERMANENTLY STABILIZED.
3. SILT FENCE SHALL BE PLACED ON SLOPE CONTOURS TO MAXIMIZE PONDING EFFICIENCY.

SILT FENCE DETAILS

NTS

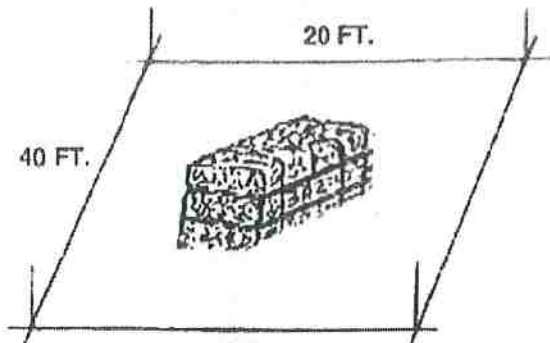
BMP: General Erosion Control (Cont.)



BMP: General Erosion Control (Cont.)

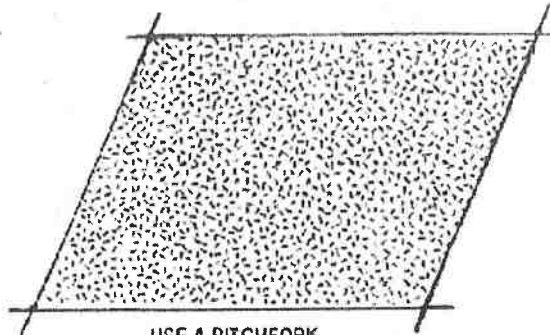
SPREAD THE STRAW

MARK OFF 800 SQ FT. PLOTS



PLACE ONE STRAW DALE PER PLOT (-74 POUNDS). THIS IS EQUIVALENT TO 2 TONS PER ACRE.

SPREAD EVENLY



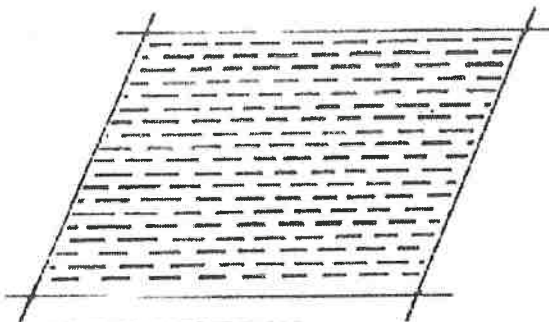
USE A PITCHFORK, SPADING FORK, OR BY HAND

ANCHOR THE STRAW

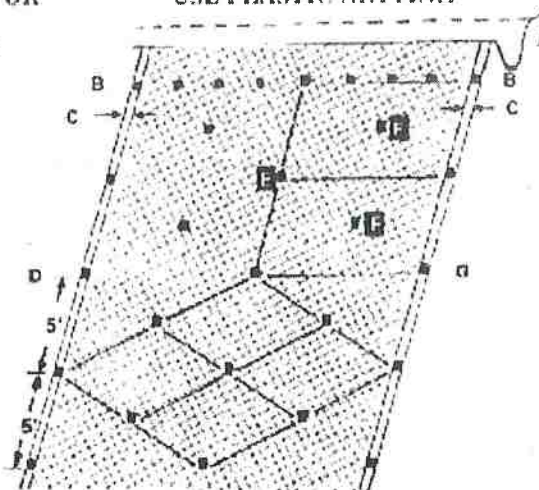
CRIMP BY HAND

OR

USE PLASTIC NETTING



WORK ACROSS THE SLOPE. PUNCH STRAW 4 INCHES DEEP. A SQUARE END SPADE WORKS WELL. MAKE PUNCH EVERY 12 INCHES.

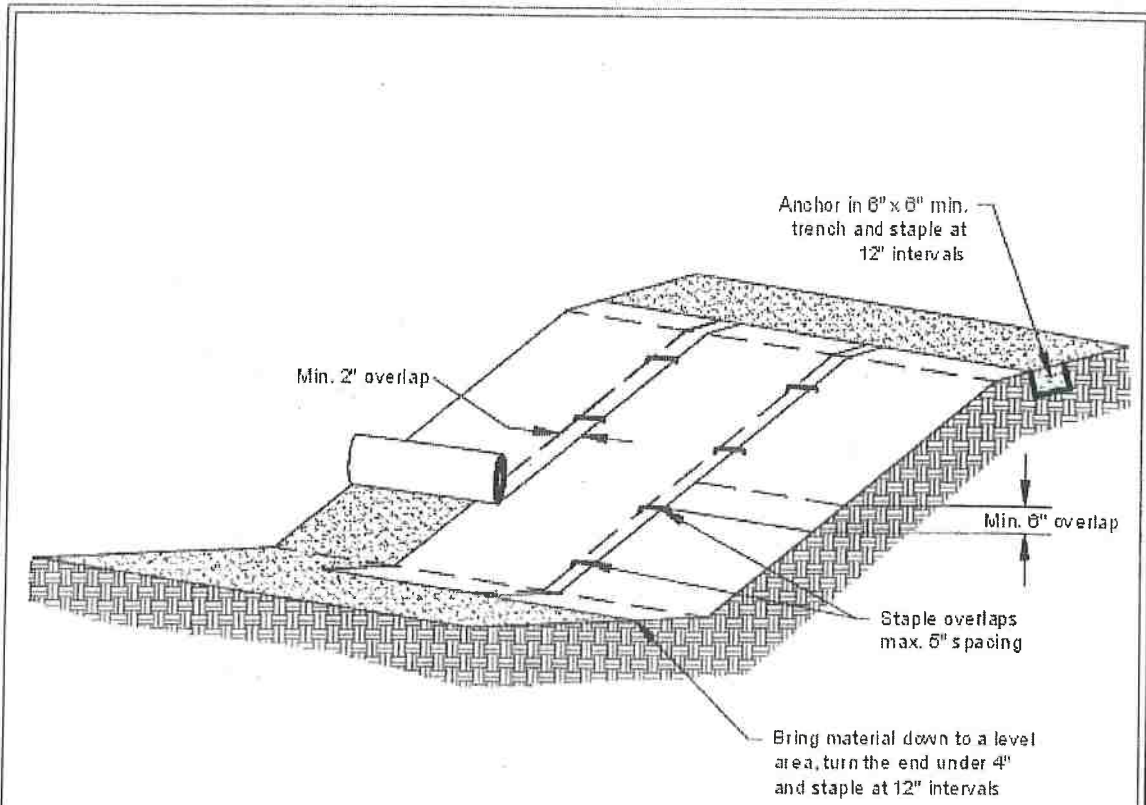


- A. LAY BIRD CONTROL NETTING OR SIMILAR MATTING IN STRIPS DOWN THE SLOPE OVER THE STRAW. BURY UPPER END IN 6-8 INCH DEEP AND WIDE TRENCH.. MOST NETTING COMES IN 14 TO 17 FT. WIDE ROLLS.
- B. SECURE THE UPPER END WITH STAKES EVERY 2 FEET.
- C. OVERLAP SEAMS ON EACH SIDE 4-5 INCHES.
- D. SECURE SEAMS WITH STAKES EVERY 5 FEET.
- E. STAKE DOWN THE CENTER EVERY 5 FEET.

- F. STAKE MIDDLES TO CREATE DIAMOND PATTERN THAT PROVIDES STAKES SPACED 4-5 FEET APART.
- G. USE POINTED 1X2 INCH STAKES 8 TO 9 INCHES LONG. LEAVE 1 TO 2 INCH TOP ABOVE NETTING, OR USE "U" SHAPED METAL PINS AT LEAST 9 INCHES LONG.

NOTE: WHEN JOINING TWO STRIPS, OVERLAP UPPER STRIP 3 FEET OVER LOWER STRIP AND SECURE WITH STAKES EVERY 2 FEET LIKE IN "B" ABOVE

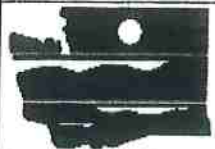
BMP: General Erosion Control (Cont.)



Notes:

1. Slope surface shall be smooth before placement for proper soil contact.
2. Stapling pattern as per manufacturer's recommendations.
3. Do not stretch blankets/mattings tight - allow the rolls to mold to any irregularities.
4. For slopes less than 3H:1V, rolls may be placed in horizontal strips.
5. If there is a berm at the top of the slope, anchor upslope of the berm.
6. Lime, fertilize, and seed before installation. Planting of shrubs, trees, etc. should occur after installation.

NOT TO SCALE



DEPARTMENT OF
ECOLOGY
State of Washington

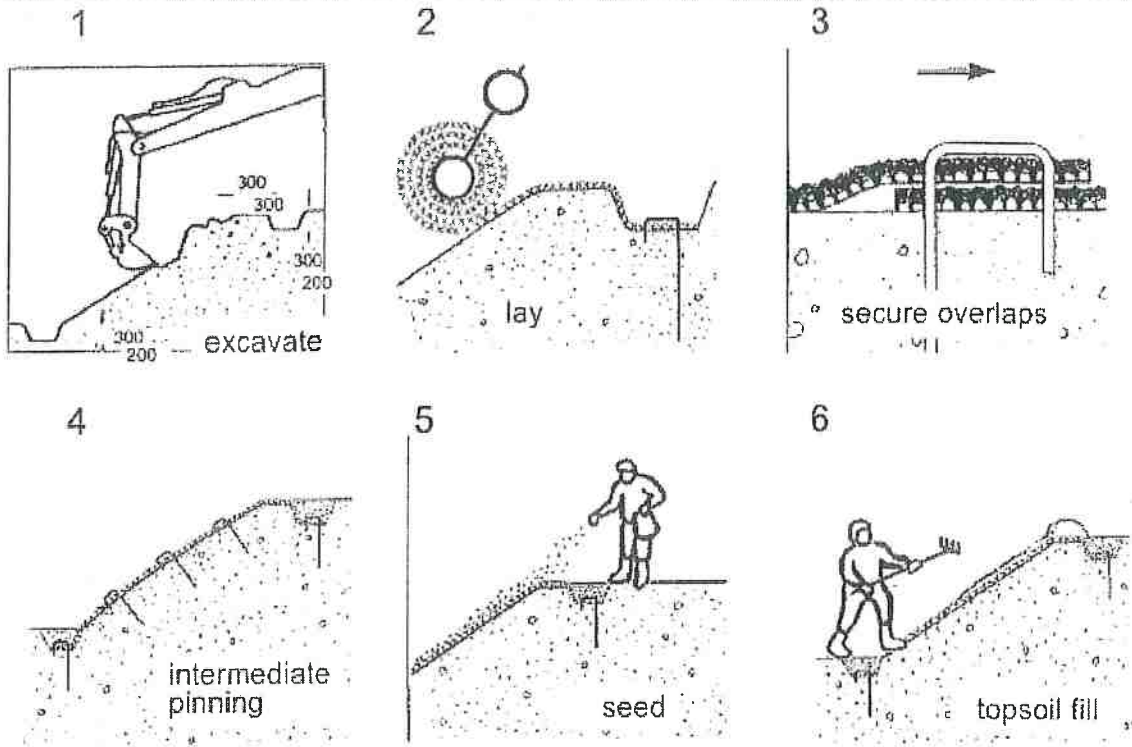
Slope Installation

Revised June 2018

Please see <http://www.ecy.wa.gov/copyright.html> for copyright notice including permissions, limitation of liability, and disclaimer.

BMP: General Erosion Control (Cont.)

Installation of a geosynthetics mat - Enkamat



BMP: General Erosion Control (Cont.)

TABLE 34. Guidelines for erosion and sediment control application

Timing of application	Technique	Portion of road and construction area treated
Erosion control during construction	Hydromulching, hydroseeding	Road fill slopes, cut slopes, bare soil areas
	Dry seeding	Road fill slopes, cut slopes, bare soil areas
	Wood chip, straw, Excelsior or tackified mulch	Road fill slopes, cut slopes, bare soil areas
	Straw wattles	Road fill slopes and cut slopes
	Gravel surfacing	Road, landing and turnout surfaces
	Dust palliative	Road surfaces
	Minimize disturbance (soil and vegetation)	All areas peripheral to construction
Sediment control during construction	Sediment basin	Roadside ditches, turnouts and small stream crossings
	Sediment traps (e.g., silt fences, straw bales barriers, woody debris barriers)	Road fill slopes, cutbanks, bare soil areas and ditches
	Straw bale dams	Ditches and small streams
	Sumps and water pumps	Stream channels and stream crossings
	Streamflow diversions (e.g., temporary culverts, flex pipe, etc.)	Stream channels and stream crossings
	Surface diversion and dispersion devices (pipes, ditches, etc.)	All disturbed bare soil areas
	Road shaping	Road and landing surfaces
	Gravel surfacing	Road, landing and turnout surfaces
	Bituminous or asphalt surfacing	Road surface
	Rolling dips	Road surface
Permanent erosion control	Ditch relief culverts	Roadbed and road fill
	Downspouts and berm drains	Road fill slopes
	Waterbars	Road and landing surfaces
	Berms	Road surface and roadside areas
	Ditches	Road and landing surfaces
	Riprap	Road fill slopes, stream crossing fills, cutbanks, stream and lake banks
	Soil bioengineering	Road fill slopes, cut slopes, stream crossings, streambanks
	Tree planting	Road fill slopes, cutbanks, bare soil areas, stream crossings, streambanks

BMP: Permanent Culvert Crossing

- New culvert installations shall be sized to accommodate flows associated with a 100-year storm event.
- If the new culvert is replacing a poorly installed old culvert, the crossing may need to be abandoned to the following standard:
 - When fills are removed they shall be excavated to form a channel that is as close as feasible to natural watercourse grade and orientation, and that is wider than the natural channel.
 - Excavated banks shall be laid back to a 2:1 (50%) or natural slope.
- New culverts shall be placed at stream gradient, or have downspouts, or have energy dissipaters at outfall.
 - Align culverts with the natural stream channel orientation to ensure proper function, prevent bank erosion, and minimize debris plugging. See Figure 97 below.
 - Place culverts at the base of the fill and at the grade of the original streambed or install a downspout past the base of the fill. Downspouts should only be installed if there are no other options.
 - Culverts should be set slightly below the original stream grade so that the water drops several inches as it enters the pipe.
 - Culvert beds should be composed of rock-free soil or gravel, evenly distributed under the length of the pipe.
 - Compact the base and sidewall material before placing the pipe in its bed.
 - Lay the pipe on a well-compacted base. Poor basal compaction will cause settling or deflection in the pipe and can result in separation at a coupling or rupture in the pipe wall.
 - Backfill material should be free of rocks, limbs, or other debris that could dent or puncture the pipe or allow water to seep around the pipe.
 - Cover one end of the culvert pipe, then the other end. Once the ends are secure, cover the center.
 - Tamp and compact backfill material throughout the entire process, using water as necessary for compaction.
 - Backfill compacting will be done in 0.5 – 1.0 foot lifts until 1/3 of the diameter of the culvert has been covered.
 - Push layers of fill over the crossing to achieve the final design road grade, road fill above the culvert should be no less than one-third to one-half the culvert diameter at any point on the drivable surface.
- Critical dips shall be installed on culvert crossings to eliminate diversion potential. Refer to Figure 84 below.
- Road approaches to crossings shall be treated out to the first drainage structure (i.e. waterbar, rolling dip, or hydrologic divide) to prevent transport of sediment.
- Road surfaces and ditches shall be disconnected from streams and stream crossings to the greatest extent feasible. Ditches and road surfaces that cannot be feasible disconnected from streams or stream crossings shall be treated to reduce sediment transport to streams.
- If downspouts are used, they shall be secured to the culvert outlet and shall be secure on fill slopes.
- Culverts shall be long enough so that road fill does not extend or slough past the culvert ends.
- Inlet of culverts, and associate fill, shall be protected with appropriate measures that extend at least as high as the top of the culvert.
- Outlet of culverts shall be armored with rock if road fill sloughing into channel can occur.
- Armor inlets and outlets with rock, or mulch and seed with grass as needed (not all stream crossings need to be armored).
- Where debris loads could endanger the crossing, a debris catchment structure shall be constructed upstream of the culvert inlet.
- Bank and channel armoring may occur, when appropriate, to provide channel and bank stabilization.

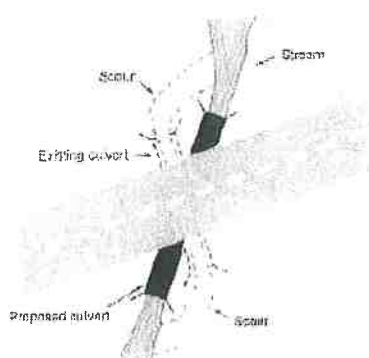


FIGURE 97. Culvert alignment should be in relation to the stream and not the road. It is important that the stream enters and leaves the culvert in a relatively straight horizontal alignment so streamflow does not have to turn to enter the inlet or discharge into a bank as it exits. This figure shows a redesigned culvert installation that replaces the bending alignment that previously existed. Channel turns at the inlet increase plugging potential because wood going through the turn will not align with the inlet. Similarly, channel turns at the inlet and outlet are often accompanied by scour against the channel banks (Wisconsin Transportation Information Center, 2004).

HANDBOOK FOR FOREST, RANCH AND RURAL ROADS

BMP: Permanent Culvert Crossing Design (Critical Dip and Hydrologic Disconnect Placement)

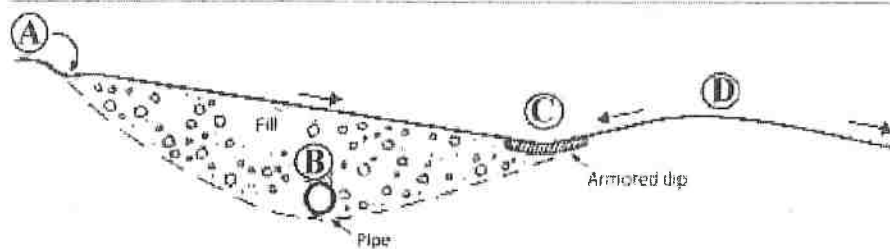
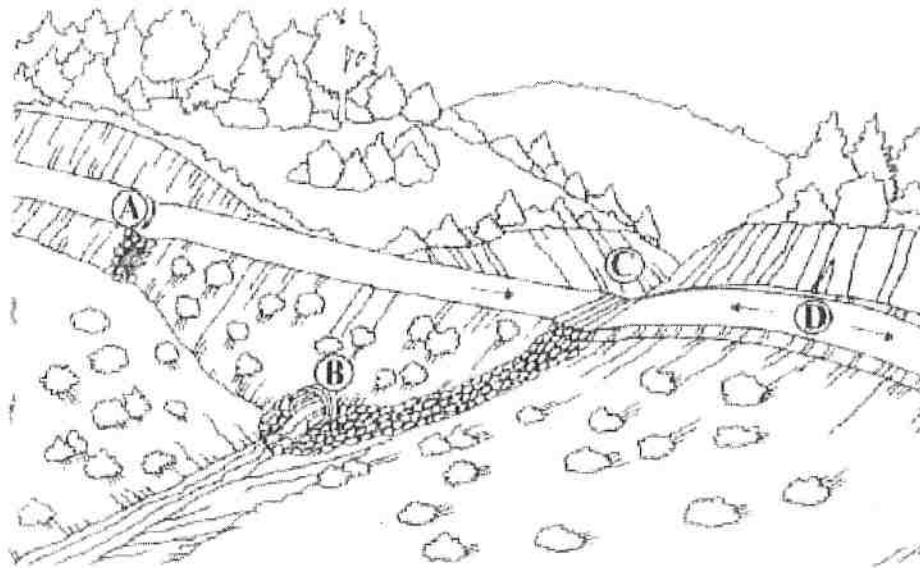
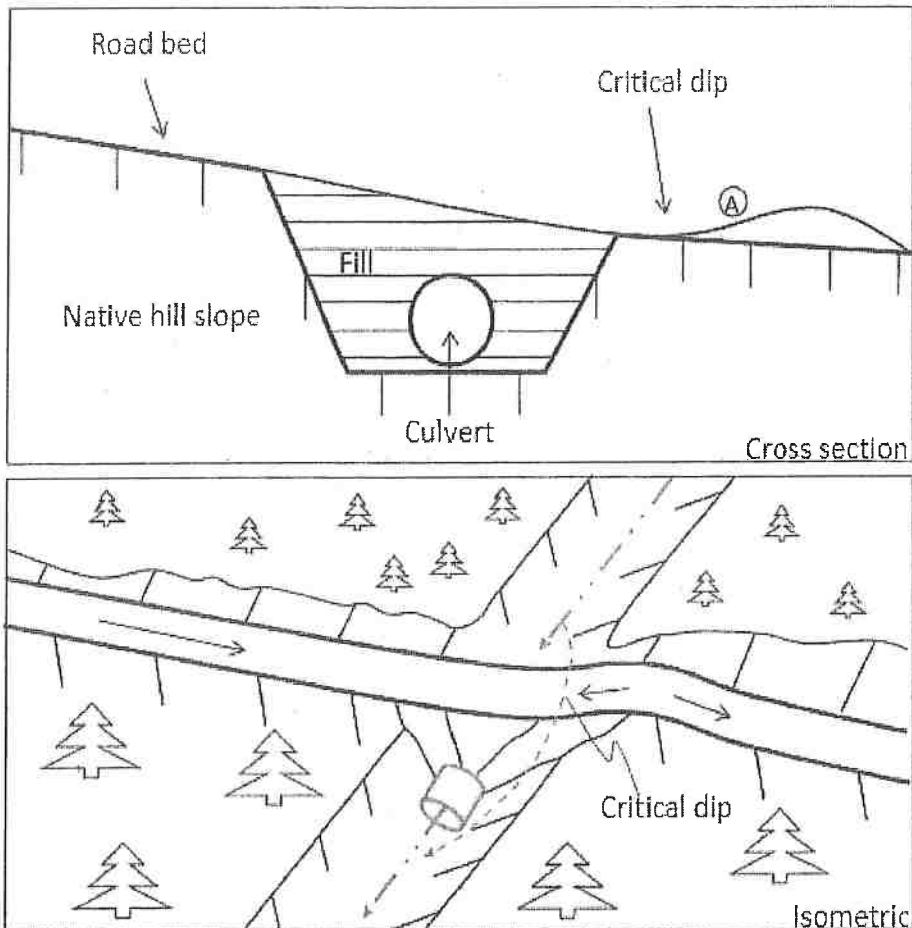


FIGURE 34. Critical dips or dipped crossing fills should be centered near a stream crossing's down-road hinge line, not over the centerline of the crossing where overtopping could cause washout or severe erosion of the fill. If the stream crossing culvert (B) plugs, water will pond behind the fill until reaching the critical dip or low point in the crossing (C) and flowing back down into the natural stream channel. The down-road ditch must be plugged to prevent streamflow from diverting down the ditch line. For extra protection in this sketch, nrap armor has been placed at the critical dip outfall and extending downslope to the stream channel. This is only required or suggested on stream crossings where the culvert is highly likely to plug and the crossing fill overtopped. The dip at the hinge line is usually sufficient to limit erosional damage during an overtopping event. Road surface and ditch runoff is disconnected from the stream crossing by installing a rolling dip and ditch relief culvert just up-road from the crossing (A) (Keller and Sherar, 2003).

BMP: Permanent Culvert Crossing Design (Critical Dip)

Typical Critical Dip Design for Stream Crossings with Diversion Potential



Critical Dip Construction:

1. Critical dip will be constructed on the lower side of crossing.
2. Critical dip will extend from the cutbank to the outside edge of the road surface. Be sure to fill inboard ditch, if present.
3. Critical dip will have a reverse grade (A) from cutbank to outside edge of road to ensure flow will not divert outside of crossing.
4. The rise in the reverse grade will be carried for about 10 to 20 feet and then return to original slope.
5. The transition from axis of bottom, through rising grade, to falling grade, will be in the road distance of at least 15 to 30 feet.
6. Critical dips are usually built perpendicular to the road surface to ensure that flow is directed back into the stream channel.

BMP: Permanent Culvert Crossing Design (Culvert Orientation)

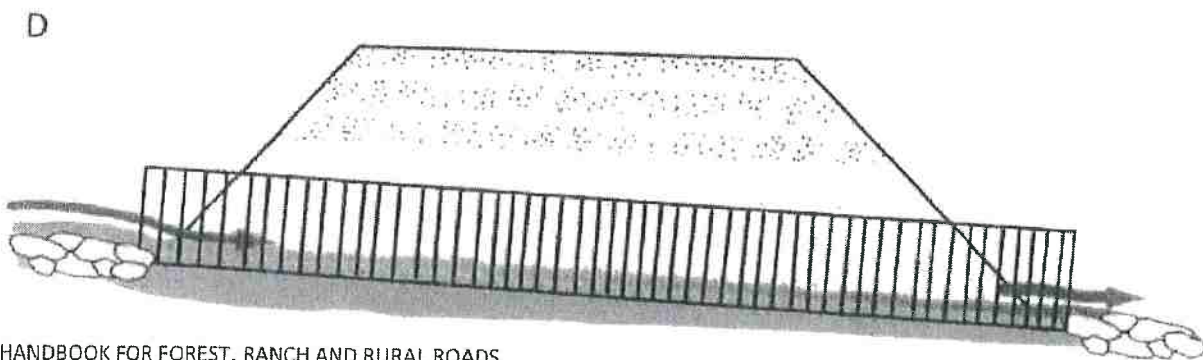
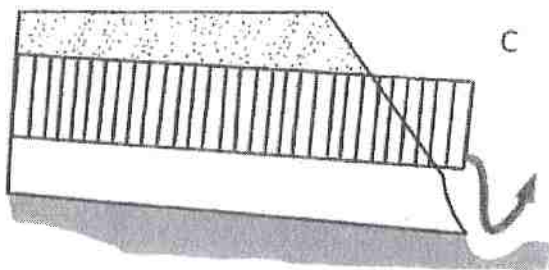
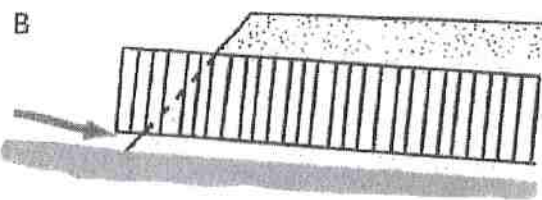
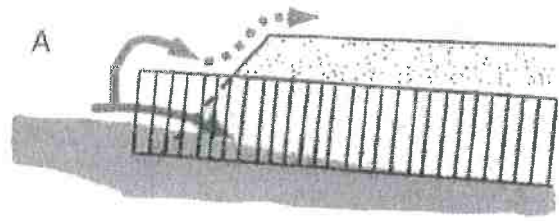
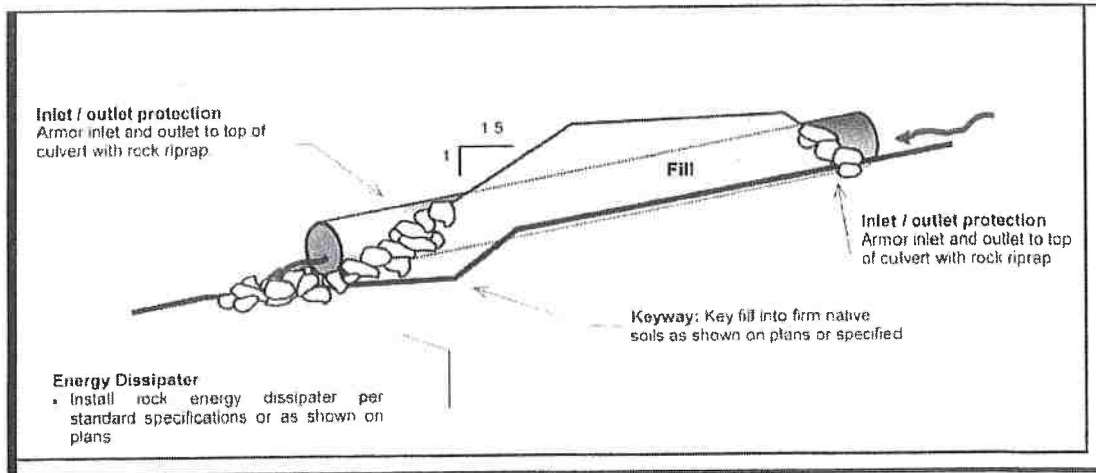
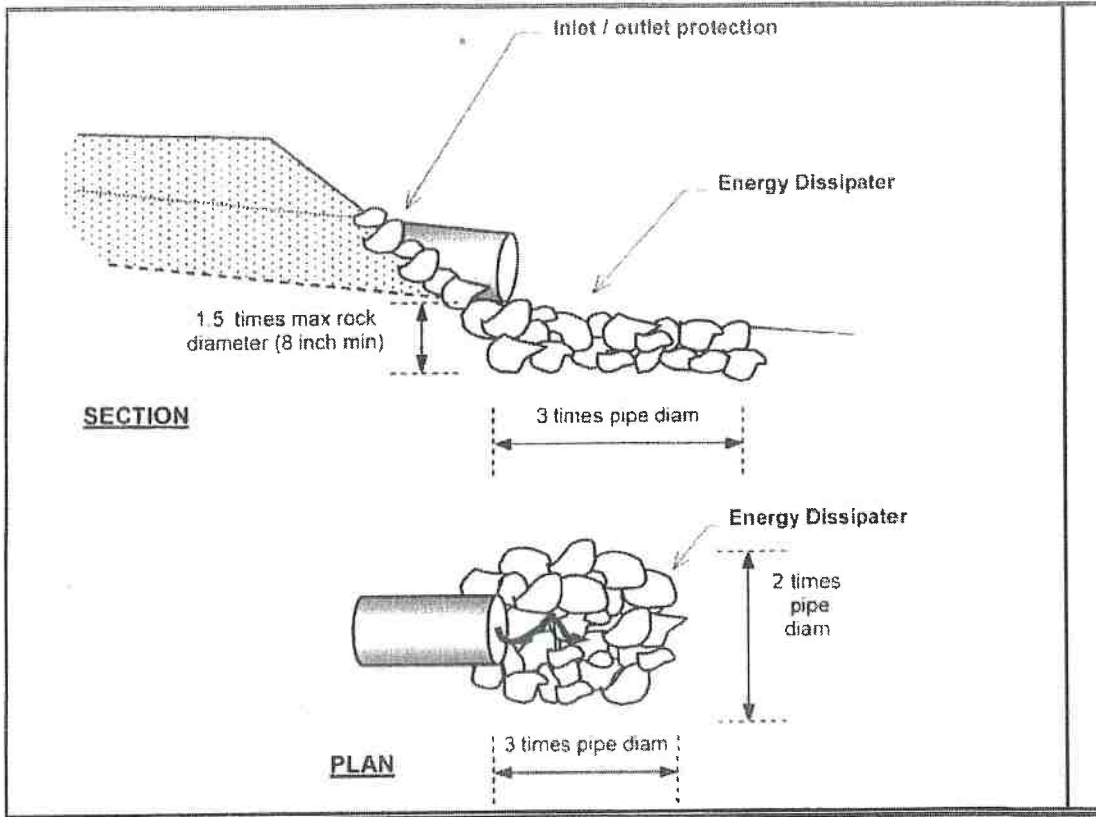


FIGURE 155. Proper culvert installation involves correct culvert orientation, setting the pipe slightly below the bed of the original stream, and backfilling and compacting the fill as it is placed over the culvert. Installing the inlet too low in the stream (A) can lead to culvert plugging, yet if set too high (B) flow can undercut the inlet. If the culvert is placed too high in the fill (C), flow at the outfall will erode the fill. Placed correctly (D), the culvert is set slightly below the original stream grade and protected with armor at the inlet and outlet. Culverts installed in fish-bearing stream channels must be inset into the streambed sufficiently (>25% embedded) to have a natural gravel bottom throughout the culvert (Modified from: MDSL, 1991).

BMP: Permanent Culvert Crossing Design (Inlet and Outlet Armoring)



Riprap installed to protect the inlet and outlet of a stream crossing culvert from erosion or for energy dissipation should be keyed into the natural channel bed and banks to an approximate depth of about 1.5x the maximum rock thickness. Riprap should be placed at least up to the top of the culvert at both the inlet and outlet to protect them from splash erosion and to trap any sediment eroded from newly constructed fill slope above.

BMP: Permanent Culvert Crossing Design (Inlet and Outlet Armoring) Cont.

- Inlets of culverts and associate fills shall be protected with rock armoring that extends at least as high as the top of the culvert.
- Outlets of culverts shall be provided a rocked energy dissipater at the outfall of the culvert.
- Outlets of culverts and associate fills shall be protected with rock armoring that extends at least as high as the top of the culvert if road fill sloughing into channel can occur.
- Prior to inlet and outlet rocking, the inlet and outlets shall be prepared. Preparation will include removal of vegetation and stored materials from the inlet and outlet.
- Inlets may require construction of an inlet basin.
- Slopes at the outlet should be shaped to a 2:1 or natural slope prior to placing rock armor.
- Rock used at culvert inlets and outlets should be a matrix of various sized rocks and rip-rap that range from a 3" dia. to a 2' dia.
- The largest rocks should be places at the base of the culvert or fill. Incrementally smaller rocks shall be placed over the larger rocks at the armoring extend up the slope. Voids and spaces shall be back filled with smaller gravels and rocks.

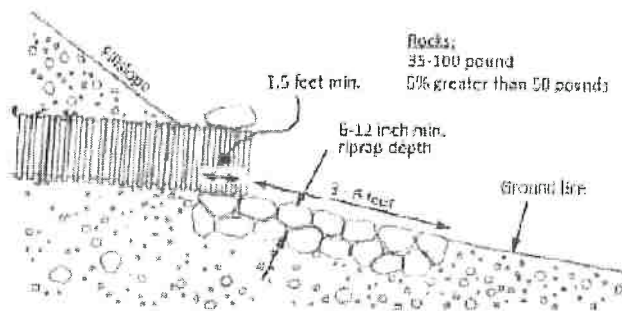


FIGURE 107A. Riprap armor at culvert outlet (Modified from: Keller et al., 2011).

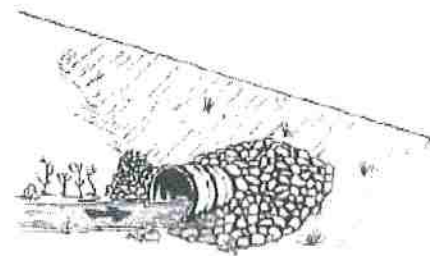


FIGURE 107B. Riprap armor at culvert inlet (Keller and Sheraz, 2003).

HANDBOOK FOR FOREST, RANCH AND RURAL ROADS

BMP: Stream Bank Armoring (Riprap)

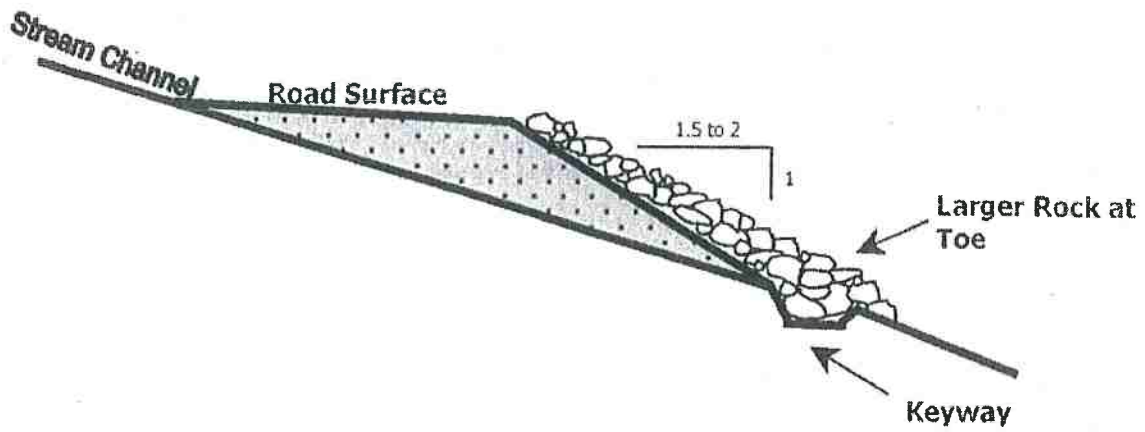
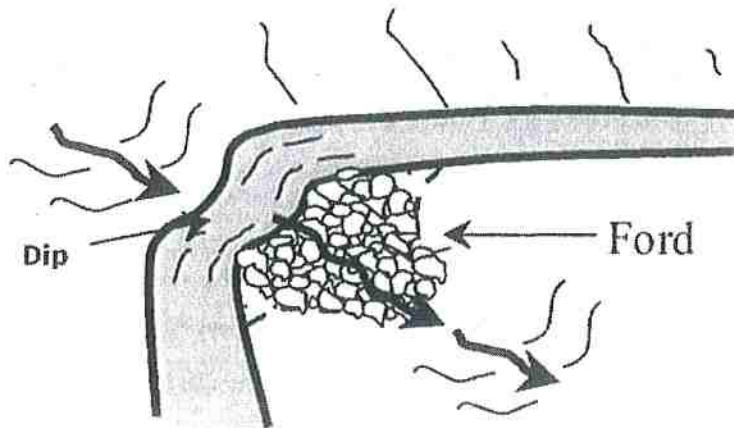
- Riprap should be installed on top of geotextile fabric or a clean mixture of coarse gravel and sand.
- The riprap should be keyed into the streambed and extend below the maximum expected scour depth with an adequately sized key base width at a thickness of a minimum of 2x the median (D50) rock diameter with the largest stone sizes placed at the base of the riprap structure.
- The armor should be set into the streambank so it does not significantly protrude into, or constrict, the natural channel, or otherwise reduce channel capacity.
- The riprap should extend along the length of unstable or over steepened bank and up the bank sufficiently to encompass the existing bank instability and/or design flood elevations.

BMP: Rocked Ford

- Rocked fords are drainage structures designed to carry watercourses across roads where culvert crossings are not feasible or un-necessary.
- In channel constructed fords shall be of appropriate material that shall withstand erosion by expected velocities and placed in a U-shaped channel to create a drivable crossing.
 - The road shall dip into and out of the rocked ford to minimize diversion potential. Construct a broad rolling dip across the roadbed, centered at the crossing, which is large enough to contain the expected 100-yr flood discharge while preventing flood flow from diverting down the road or around the rock armor.
- The road surface at the ford shall be constructed with clean rock. The rock shall be applied to a minimum depth of 6 inches.
 - A range of interlocking rock armor sizes should be selected and sized so that peak flows will not pluck or transport the armor off the roadbed or the sloping fill face of the armored fill.
- The ford's outlet shall be rock armored to resist downcutting and erosion.
 - *Excavate the keyway and armored area* - Excavate a two to three-foot-deep "bed" into the dipped road surface and adjacent fillslope (to place the rock in) that extends from approximately the middle of the road, across the outer half of the road, and down the outboard road fill to where the base of the fill meets the natural channel. At the base of the fill, excavate a keyway trench extending across the channel bed.
 - *Armor the basal keyway* - Put aside the largest rock armoring to create the buttresses. Use the largest rock armor to fill the basal trench and create a buttress at the base of the fill. This should have a "U" shape to it and it will define the outlet where flow leaves the armored fill and enters the natural channel.
 - *Armor the fill* - Backfill the fill face with the remaining rock armor making sure the final armor is unsorted and well placed, the armor is two coarse-rock layers in thickness, and the armored area on the fill face also has a "U" shape that will accommodate the largest expected flow.
 - *Armor the top of the fill* - Install a second trenched buttress for large rock at the break-in-slope between the outboard road edge and the top of the fill face.
- If water is expected during the time of use, an adequately sized pipe shall be installed to handle the flow if present (min. 6 inch).
 - The pipe shall be laid over the rocked ford surface.
 - The inlet should be at grade with the upstream flow.
 - The outlet shall drain onto the outlet armoring of the rocked ford.
 - A layer of clean rock/gravel shall be installed over the pipe to establish the running surface of the truck road.
 - Following use, the temporary pipe shall be removed and the placed rock/gravel shall be graded out of the ford and used on the approaches.
 - No significant alteration to the bed and bank of the stream shall occur.
- Road approaches to rocked fords shall be rock surfaced out to the first drainage structure (i.e. waterbar) or hydrologic divide to prevent transport of sediment using rock.
- Bank and channel armoring may occur when appropriate to provide channel and bank stabilization.
- Road approach rock and rock ford armoring shall be reapplied following use as needed to maintain a permanent crossing.

BMP: Rocked Ford (Cont.)

FORD: A large dip is graded into the road at the axis of the stream channel. The outside fill face is dished out to form a spillway with large rock. On large watercourses, rock is keyed several feet into firm native soils. The road surface is rocked with 6" of minus rock.



BMP: Armored Ford (Fill)

- Armored fords are drainage structures designed to carry watercourses across roads.
- Armored fords shall have a U-shaped channel to create a drivable crossing.
 - The road shall dip into and out of the armored ford to minimize diversion potential. Construct a broad rolling dip across the roadbed, centered at the crossing, which is large enough to contain the expected 100-yr flood discharge while preventing flood flow from diverting down the road or around the rock armor.
- The road surface at the armored ford shall utilize native soils.
- The ford's inlet shall be rock armored if a threat of head cutting exists.
 - *Excavate the keyway* - Excavate a one to three-foot-deep "bed" into the inboard edge of the road
 - *Armor the basal keyway* - place various sized rock in the constructed keyway to prevent head cutting. Use the largest rock armor to fill the keyway trench and create a buttress along the inboard edge of the road. This should have a "U" shape to it and it will define the inlet where flow leaves the natural channel and enters the road.
- The ford's outlet shall be rock armored to resist downcutting and erosion.
 - *Excavate the keyway and armored area* - Excavate a two to three-foot-deep "bed" into the dipped road surface and adjacent fillslope (to place the rock in) that extends from approximately the middle of the road, across the outer half of the road, and down the outboard road fill to where the base of the fill meets the natural channel. At the base of the fill, excavate a keyway trench extending across the channel bed.
 - *Armor the basal keyway* - Put aside the largest rock armoring to create the buttresses. Use the largest rock armor to fill the basal trench and create a buttress at the base of the fill. This should have a "U" shape to it and it will define the outlet where flow leaves the armored fill and enters the natural channel.
 - *Armor the fill* - Backfill the fill face with the remaining rock armor making sure the final armor is unsorted and well placed, the armor is two coarse-rock layers in thickness, and the armored area on the fill face also has a "U" shape that will accommodate the largest expected flow.
 - *Armor the top of the fill* - Install a second trenched buttress for large rock at the break-in-slope between the outboard road edge and the top of the fill face.
- If water is expected during the time of use, an adequately sized pipe shall be installed to handle the flow if present (min. 6 inch).
 - The pipe shall be laid over the armored ford surface.
 - The inlet should be at grade with the upstream flow.
 - The outlet shall drain onto the outlet armoring of the rock armored ford.
 - A layer of clean native soil shall be installed over the pipe to establish the running surface of the truck road.
 - Following use, the temporary pipe shall be removed and the placed native soil shall be removed and drifted along the approaches.
 - No significant alteration to the bed and bank of the stream shall occur.
- Road approaches to armored fords shall be treated with seed and straw mulch out to the first drainage structure (i.e. waterbar) or hydrologic divide to prevent transport of sediment pursuant to Item 18, Section II.
- Bank and channel armoring may occur when appropriate to provide channel and bank stabilization.
- Armored ford armoring shall be reapplied following use as needed to maintain a permanent crossing.

BMP: Armored Ford [Fill] (Cont.)



FIGURE 120. This armored fill crossing of a steep, ephemeral stream was constructed to provide a low maintenance crossing. The crossing has been deeply dipped to reduce the volume of road fill and to eliminate the potential for stream diversion. The fill slope has been heavily armored through the axis of the crossing to contain flood flows and prevent down-cutting. Armored fills cannot be used on fish bearing streams.

HANDBOOK FOR FOREST, RANCH AND RURAL ROADS

BMP: Armored Ford [Fill] (Cont.)



FIGURE 121D. Well graded rock armor is then hauled into the structure and spread across the breadth of the U-shaped stream crossing, and about one-third the way up the roadbed, so that streamflow will only flow over or come in contact with resistant armor material. The armor must be spread and compacted across the design width of the expected flood flow channel width so peak flows will not bank the armored structure.



FIGURE 121E. Two weeks after this armored fill was constructed, a storm flow event occurred and the structure maintained its function and integrity. The road approaches had not yet been compacted or surfaced with road rock.

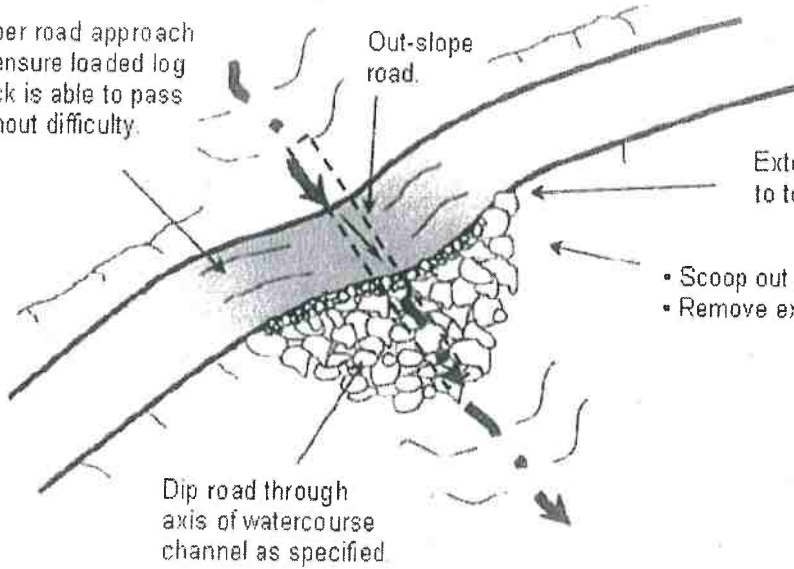


FIGURE 121F. The same armored fill as it appeared after the first winter flood flows. No maintenance was required to reopen the road. It is also clear that no stream diversion is possible at this stream crossing site, and the volume of fill within the crossing has been reduced to the minimum amount needed to maintain a relatively smooth driving surface on this low volume road.

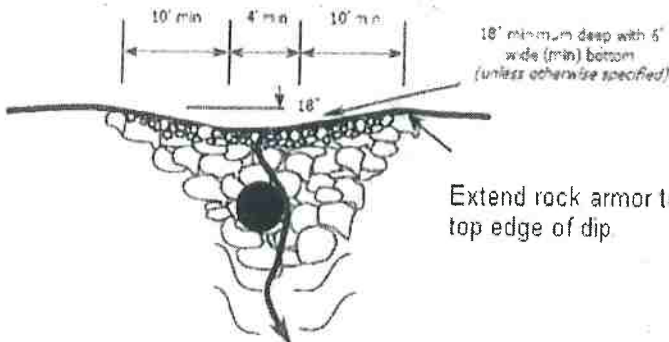
BMP: Vented Ford

Vented Ford

Taper road approach to ensure loaded log truck is able to pass without difficulty.

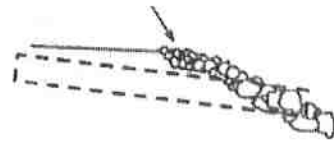


Dip area to accommodate a culvert sized for 100-year flow (minimum dimensions given below).



LIP

- Use smaller rock at lip of ford.
- Fill voids with smaller rock to prevent piping around the larger rock.



BMP: Crossing Abandonment

- Excavate and removing all fill materials placed in the stream channel when the crossing was originally built.
- Excavated banks shall be laid back to a 2:1 (50%) or natural slope to prevent slumping and soil movement.
- Fill material should be excavated to recreate the original channel grade (slope) and orientation.
- All bare soils should then be mulched, seeded, and planted to minimize erosion until vegetation can protect the soil surface.
- The approaching road segments shall be cross-road(waterbars) drained to prevent road runoff from discharging across the freshly excavated channel sideslopes.
- When fills are removed, they shall be excavated to form a channel that is as close as feasible to natural watercourse grade and orientation.
- The excavated channel bed should be as wide, or slightly wider than, the original watercourse channel.
 - This can be better determined by observing the channel width of the watercourse up slope of crossing to be removed at a point in which the crossing or any other disturbance has not affected the natural channel slope and width.
- Temporary crossings shall be removed by November 15.
 - Any temporary culvert crossing left in after October 15 or installed between October 15 and May 1, shall be sized to accommodate the estimated 100-year flow.
- In certain situations, bank and channel rock and woody debris armoring may be appropriate to provide channel and bank stabilization.

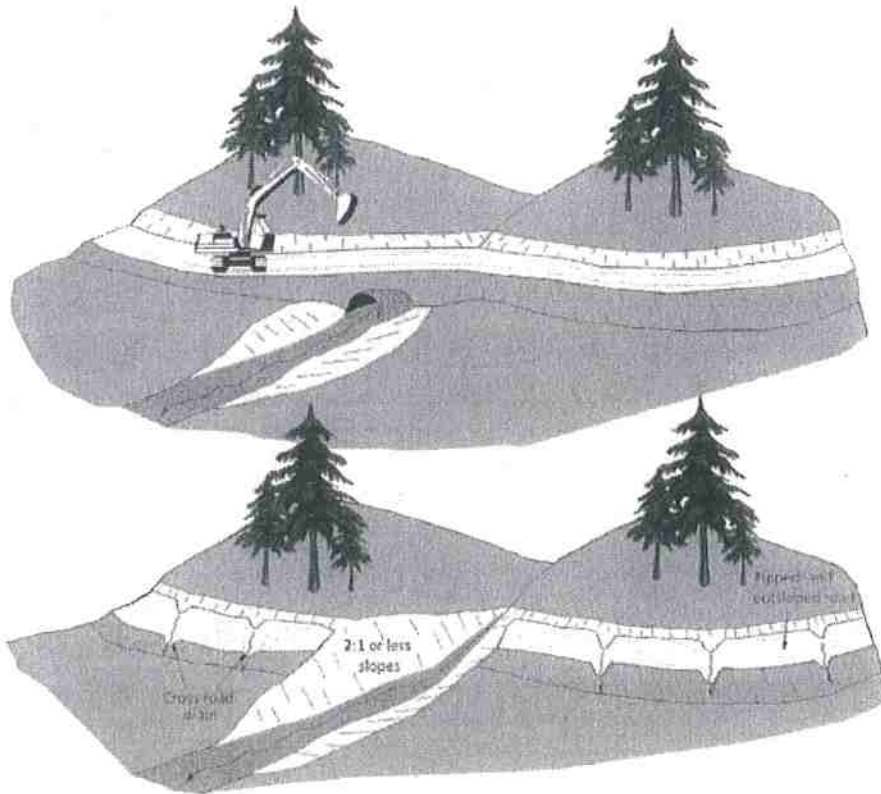


FIGURE 263. On roads that are to be closed (decommissioned), all stream crossing culverts and fills should be removed. Stream crossing excavations are best performed using an excavator. The original channel should be excavated and exhumed down to the former streambed, with a channel width equal or greater than the natural channel above and below the crossing. Sideslopes should be laid back to a stable angle, typically a 2:1 (50%) gradient, or less. Spoil can be endhailed off-site or stored on the road bench adjacent the crossing, provided it is placed and stabilized where it will not erode or fail and enter the stream.

BMP: Rolling Dip Design and Placement

- Rolling dips are drainage structures designed to force surface water to be drained from the road surface.
- The road shall dip into, and rise out of, the rolling dip to eliminate the potential of road surface runoff to run further down road way.
- The rolling dip shall be constructed with clean native materials or rock surfaced where specified.
- The rolling dips outlet may be armored to resist down-cutting and erosion of the outboard road fill.
- Do not discharge rolling dips into any areas that show signs of instability or active landsliding.
- If the rolling dip is designed to divert both road surface and ditch runoff, block the down-road ditch with compacted fill in order to force all ditch flows through the trough (low point) of the rolling dip.

BMP: Rocked Rolling Dip Design and Placement

- Rocked rolling dips are drainage structures designed to carry known sources of surface water across road ways or from known persistently wet segments of road such as swales without defined watercourses or road segments with heavy bank/road seepage.
- The road shall dip into, and rise out of, the rocked rolling dip to minimize diversion potential.
- The rocked rolling dip shall be constructed with clean rock that is large enough to remain in place during peak flows. Rock size shall vary relative to the anticipated flow through the dip with larger rock used in location where greater flow is anticipated.
- The rocked rolling dips inlet and outlet shall be armored to resist down-cutting and erosion.
- The entire width of the rocked rolling dip shall be rock armored to a minimum of 5-feet from the centerline of the dipped portion of the rolling dip.
- If a keyway is necessary, the rocked rolling dip keyway at the base of the dip shall be of sufficient size, depth and length to support materials used in the rocked rolling dip construction back up to the road crossing interface.
- Do not discharge rolling dips into any areas that show signs of instability or active landsliding.
- If the rolling dip is designed to divert both road surface and ditch runoff, block the down-road ditch with compacted fill.
- The rolling dip should be designed as a broad feature ranging from 10-100 feet long so that it is drivable by most types of vehicular traffic and not significantly inhibit traffic and road use.

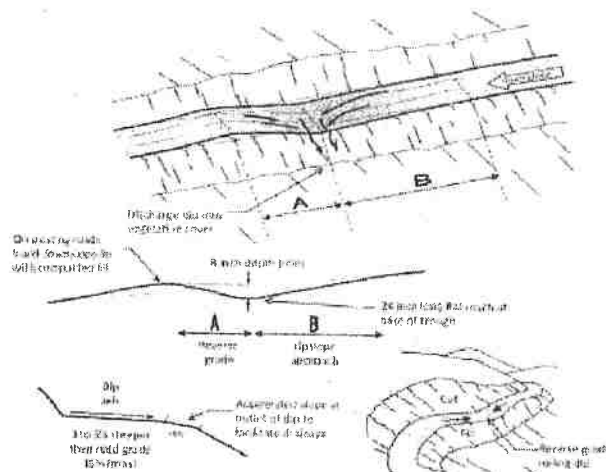
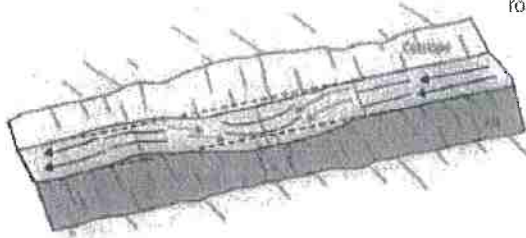


FIGURE 34. A classic Type I rolling dip, where the excavated up-road approach (B) to the rolling dip is several percent steeper than the approaching road and extends for 80 to 80 feet to the dip axis. The lower side of the structure reverses grade (A) over approximately 16 feet or more, and then falls down to rejoin the original road grade. The dip must be deep enough that it is not obliterated by normal grading, but not so deep that it is difficult to negotiate or a hazard to normal traffic. The outward cross-slope of the dip axis should be 3% to 5% greater than the up-road grade (B) so it will drain properly. The dip axis should be out-sloped sufficiently to be self-cleaning, without triggering excessive downcutting or sediment deposited in the dip axis (Adapted from Best, 2013).

HANDBOOK FOR FOREST, RANCH AND RURAL ROADS

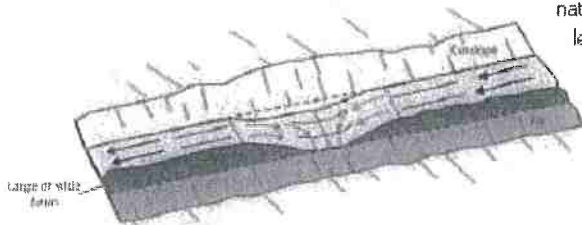
BMP: Rolling Dip Design and Placement (Types)

Type 1 Rolling Dip (Standard)



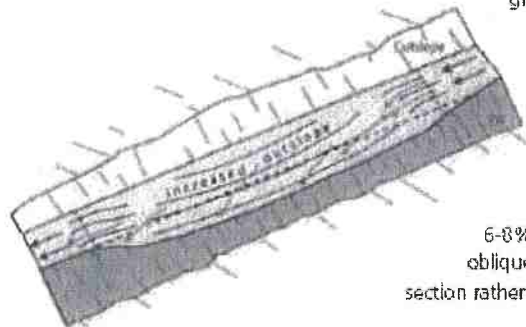
Type 1 rolling dips are used where road grades are less than about 12-14% and road runoff is not confined by a large through cut or berm. The axis of the dip should be perpendicular to the road alignment and sloped at 3-4% across the road tread. Steep roads will have longer and more abrupt dip dimensions to develop reverse grade through the dip axis. The road tread and/or the dip outlet can be rocked to protect against erosion, if needed.

Type 2 Rolling Dip (Through-cut or thick berm road reaches)



Type 2 rolling dips are constructed on roads up to 12-14% grade where there is a through cut up to 3 feet tall, or a wide or tall berm that otherwise blocks road drainage. The berm or native through cut material should be removed for the length of the dip, or at least through the axis of the dip, to the extent needed to provide for uninterrupted drainage onto the adjacent slope. The berm and slope material can be excavated and endhauded, or the material can be sidecast onto native slopes up to 45%, provided it will not enter a stream.

Type 3 Rolling Dip (Steep road grade)



Type 3 rolling dips are utilized where road grades are steeper than about 12% and it is not feasible to develop a reverse grade that will also allow passage of the design vehicle (steep road grades require more abrupt grade reversals that some vehicles may not be able to traverse without bottoming out).

Instead of relying on the dip's grade reversal to turn runoff off the roadbed, the road is built with an exaggerated outslope of 6-8% across the dip axis. Road runoff is deflected obliquely across the dip axis and is shed off the outsloped section rather than continuing down the steep road grade.

FIGURE 36. Rolling dip types

BMP: Rolling Dip Design and Placement

FIGURE 33A.

Rolling dip constructed on a rock surfaced rural road. The rolling dip represents a change-in-grade along the road alignment and acts to discharge water that has collected on, or is flowing down, the road surface. This road was recently converted from a high maintenance, insloped, ditched road to a low maintenance, outsloped road with rolling dips.

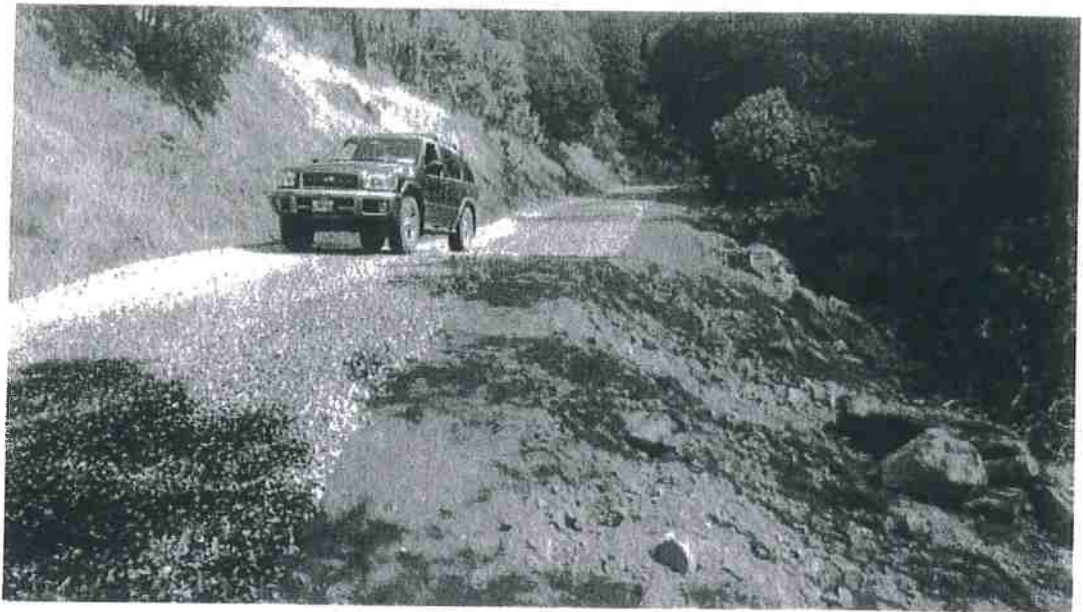


FIGURE 33B.

This side view of an outsloped road shows that the rolling dip does not have to be deep or abrupt to reverse road grade and effectively drain the road surface. This outsloped forest road has rolling dips that allow all traffic types to travel the route without changing speed.



BMP: Waterbar/Rolling Dip Combined with DRC



FIGURE 39.

Waterbars are often used to drain surface runoff from seasonal, unsurfaced roads. Because they are easily broken down by vehicles, waterbars are only used on unsurfaced roads where there is little or no wet weather traffic. In this photo, a waterbar and ditch relief culvert are used to drain all road surface and ditch runoff from the insloped road prism.

HANDBOOK FOR FOREST, RANCH AND RURAL ROADS

Diagram shows and discussed the use of a waterbar. However, a DRC combined with a rolling dip structure provides the same surface and ditch drainage for roads used year-round. Just as with the waterbar in the photo above, The DRC is installed just upslope from the rolling dip. This also creates a fail-safe should the DRC become plugged or overwhelmed.

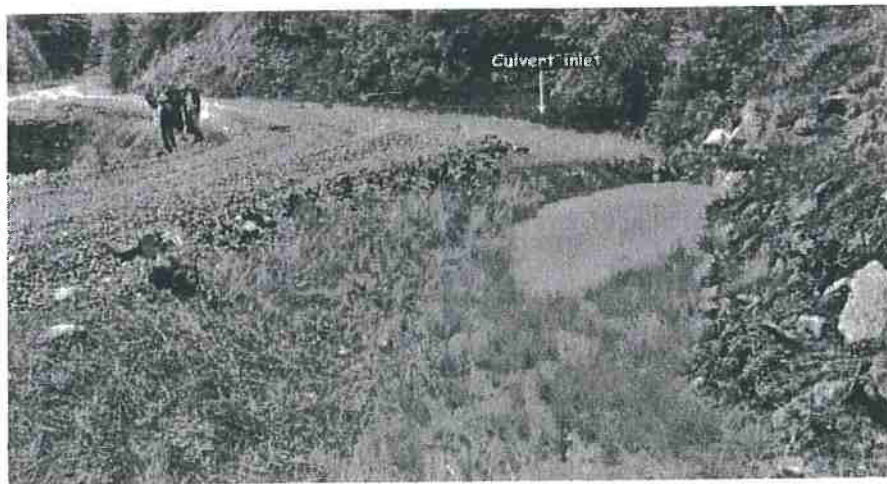
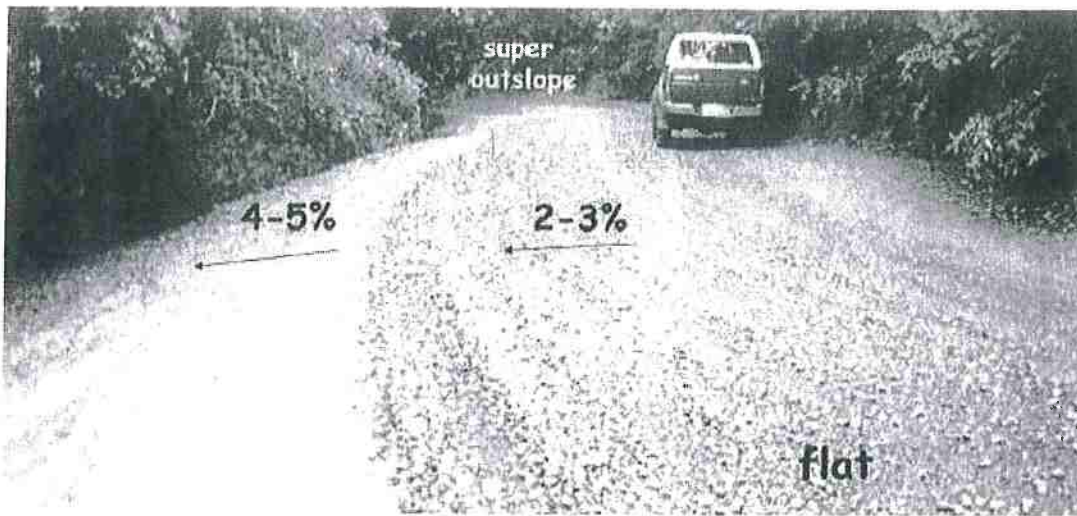


FIGURE 238. Traffic and surface runoff from graveled roads often produces surface erosion, turbid runoff and fine sediment transport that can be delivered to streams. Where ditches can't be eliminated, sediment traps and roadside settling basins can be installed to capture and remove most of the eroded sediment. This settling basin has been constructed along the inside ditch just before a stream crossing culvert inlet (see arrow). Eroded sediment from the road and ditch are deposited in the basin before flow is released to the stream. Fine sediments have filled about 1/3 of this basin and vegetation is now growing. Sediment basins require periodic maintenance to maintain their storage capacity.

HANDBOOK FOR FOREST, RANCH AND RURAL ROADS

BMP: Road Outsloping



HANDECK FOR FOREST, RANCH, AND RURAL ROADS

FIGURE 29. Road shape changes as the road travels through the landscape. For example, an out-sloped road will have a steep or "banked" outslope through inside curves, a consistent outslope through straight reaches and a flat or slightly insloped shape as it goes through an outside curve. The road may have an outslope of 2-3% across the travel surface while the shoulder is more steeply outsloped to ensure runoff and sediment will leave the roadbed.

BMP: Steep Road Drainage Structures



FIGURE 55. Steep roads that go straight up or down a hillside are very difficult to drain. This steep, fall line road developed a through cut cross section that was drained using lead out ditches to direct runoff off the road and onto the adjacent, vegetated hillside. The road was "outsloped" to drain runoff to the right side, and the lead out ditch was built slightly steeper than the road grade, to be self-cleaning. Four lead out ditches have been constructed at 100-foot intervals to the bottom of the hillside.

HANDBOOK FOR FOREST, RANCH AND RURAL ROADS

BMP: Ditch Relief Culvert

- Install ditch relief culverts at an oblique (typically 30 degree) angle to the road so that ditch flow does not have to make a sharp angle turn to enter the pipe. On low gradient roads (<5%), where ditch flow is slow, ditch relief culverts can be installed at right angles to the road.
- Install ditch relief culverts (DRC) to outlet at, and drain to, the base of the fill
- If it cannot be installed at the base of the fill, install the DRC with a grade steeper than the inboard ditch draining to the culvert inlet, and then install a downspout on the outlet to carry the culverted flow to the base of the fillslope or energy dissipater material at outlet to prevent erosion or the outboard road fill.
- Downspouts longer than 20 feet should be secured to the hillslope for stability.
- Ditch relief culverts should not carry excessive flow such that gulying occurs below the culvert outlet or such that erosion and down-cutting of the inboard ditch is occurring.
- Do not discharge flows from ditch relief culverts onto unstable areas or highly erodible hillslopes.
- If the ditch is on an insloped or crowned road, consider reshaping road outsloping to drain the road surface. The ditch and the ditch relief culvert would then convey only spring flow from the cutbank and hillslope runoff, and not turbid runoff from the road surface.

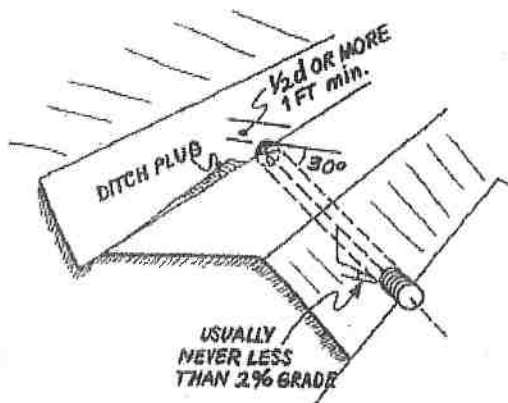
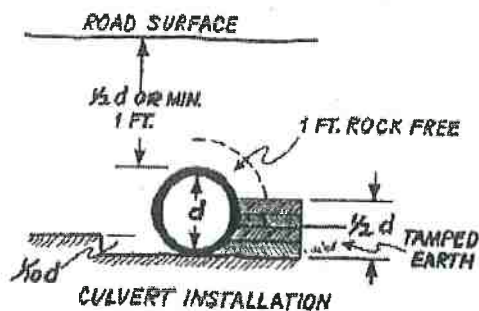
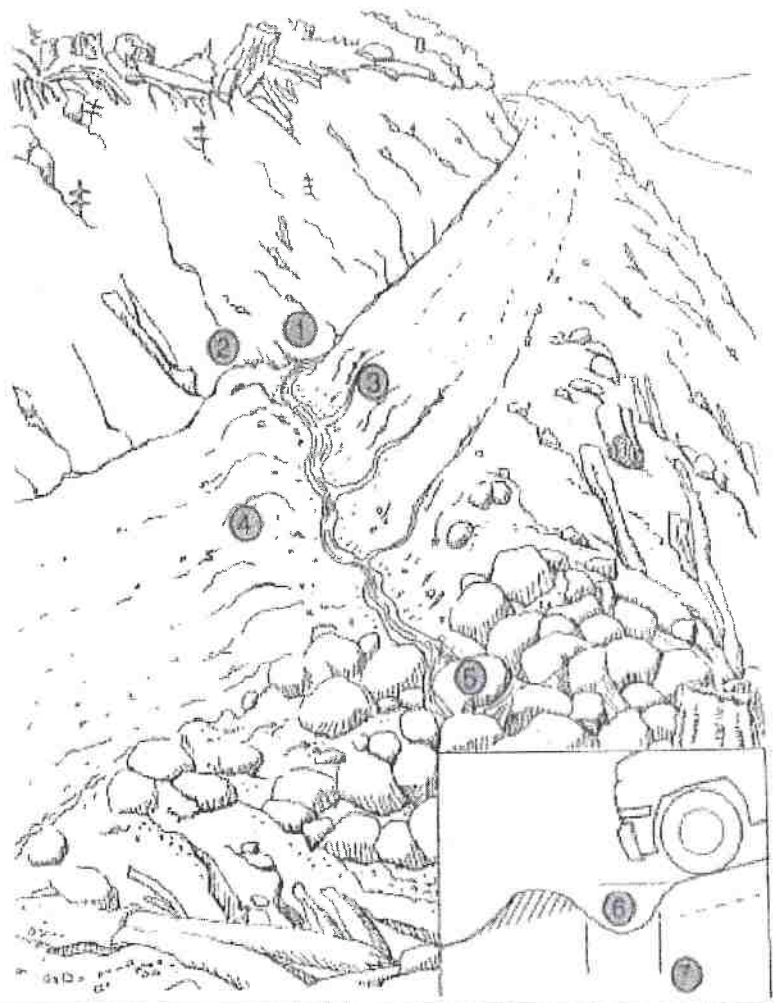


FIGURE 48. The elements of a properly installed ditch relief culvert. The culvert is angled at about 30 degrees to the road alignment to help capture flow and prevent culvert plugging or erosion of the inlet area. It is set at the base of the fill (ideally) or with a grade slightly steeper than the grade of the contributing ditch (but never with a grade less than 2 percent) (USDA-SCS, 1983). At a minimum, the grade of the ditch relief culvert should be sufficient to prevent sediment accumulation at the inlet or deposition within the culvert itself (it should be self-cleaning) (USDA-SCS, 1983).



BMP: Waterbar Construction

FIGURE 40. Waterbars are constructed on unsurfaced forest and ranch roads that will have little or no traffic during the wet season. The waterbar should be extended to the cutbank to intercept all ditch flow (1) and extend beyond the shoulder of the road. A berm (2) must block and prevent ditch flow from continuing down the road during flood flows. The excavated waterbar (3) should be constructed to be self-cleaning, typically with a 30° skew to the road alignment with the excavated material bermed on the downhill grade of the road (4). Water should always be discharged onto the downhill side on a stable slope protected by vegetation. Rock (shown in the figure) should not be necessary if waterbars are spaced close enough to prevent serious erosion. (5) The cross ditch depth (6) and width (7) must allow vehicle cross-over without destroying the function of the drain. Several alternate types of waterbars are possible, including one that drains only the road surface (not the ditch), and one that drains the road surface into the inside ditch (BCMF, 1991).



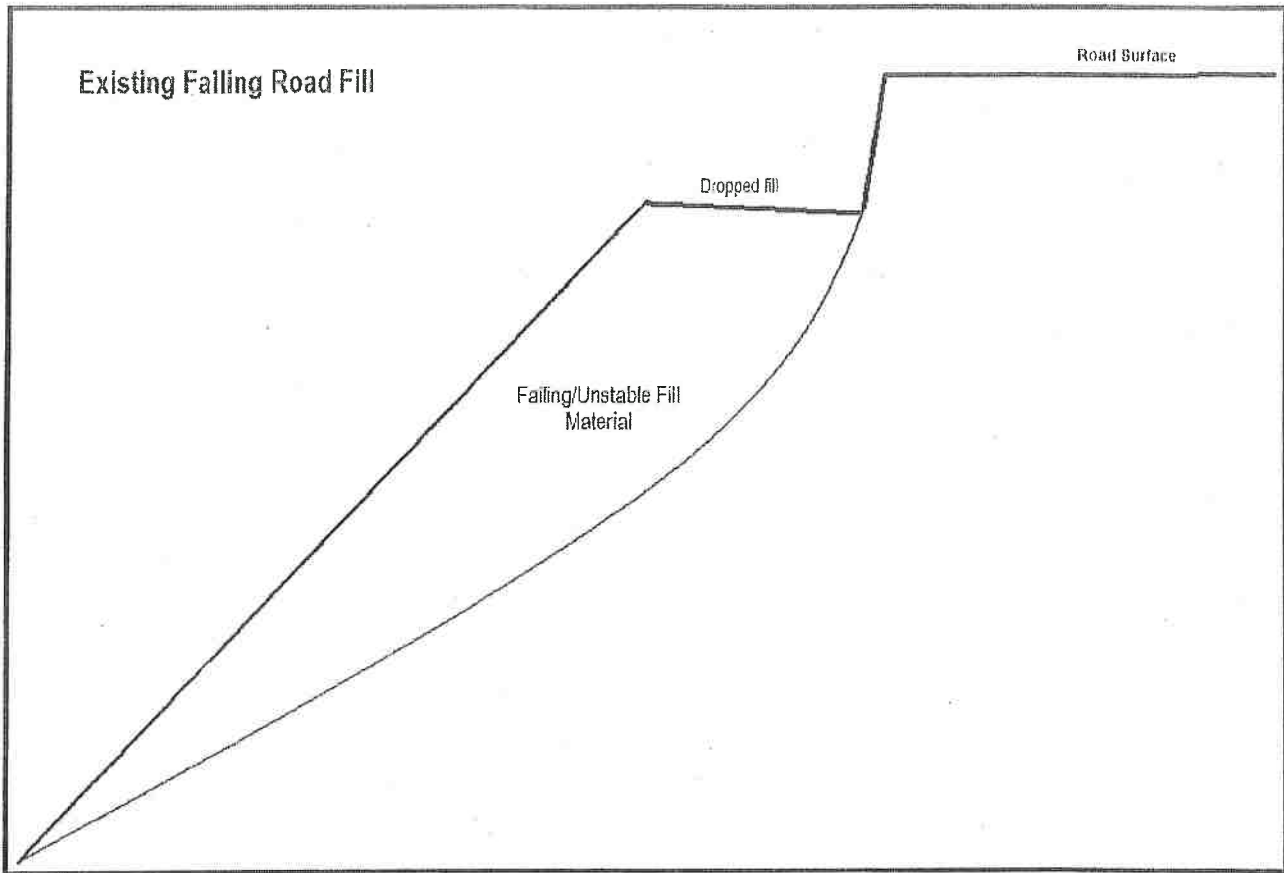
HANDBOOK FOR FOREST, RANCH, AND RURAL ROADS

BMP: Unstable Fill Removal and Treatment

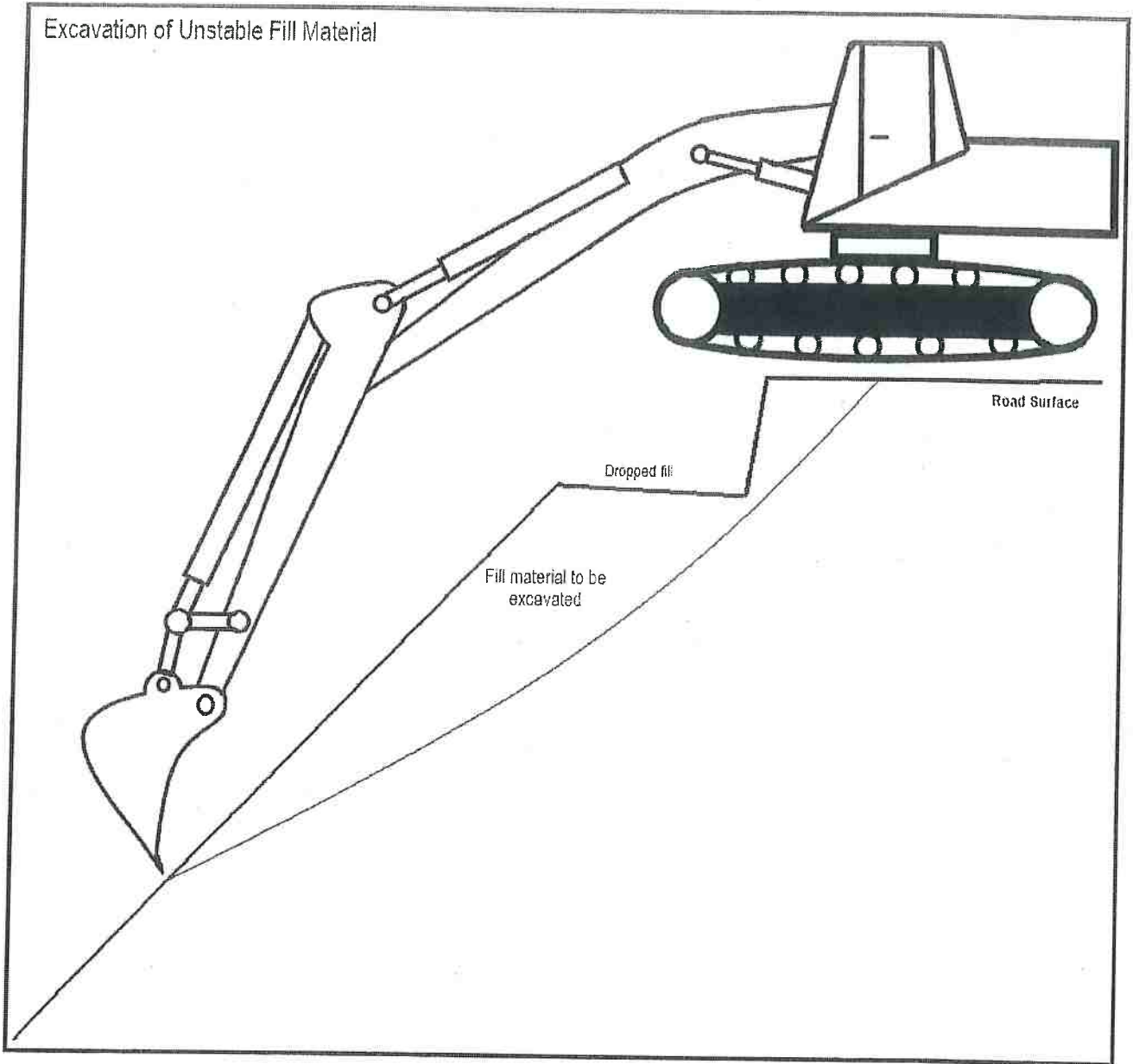


FIGURE 230. The most cost-effective treatment for unstable fills along the outside of a forest, ranch or rural road is simply the direct excavation of the unstable material. If road width is too narrow, additional width can often be derived from cutting into the bank. The excavation should encompass the unstable fill materials, beginning at the inside crack or scarp, and extending out and down the fill slope as far as possible. For proper surface drainage, and to retrieve most of the unstable fill, the excavation should have a concave profile when completed. Typically, the bulk of the fill is within 20 to 25 feet of the outside edge of the road and is easily reached by a midsized excavator. Any remaining fill is likely to be small enough that it will not fail or travel far enough to reach the stream.

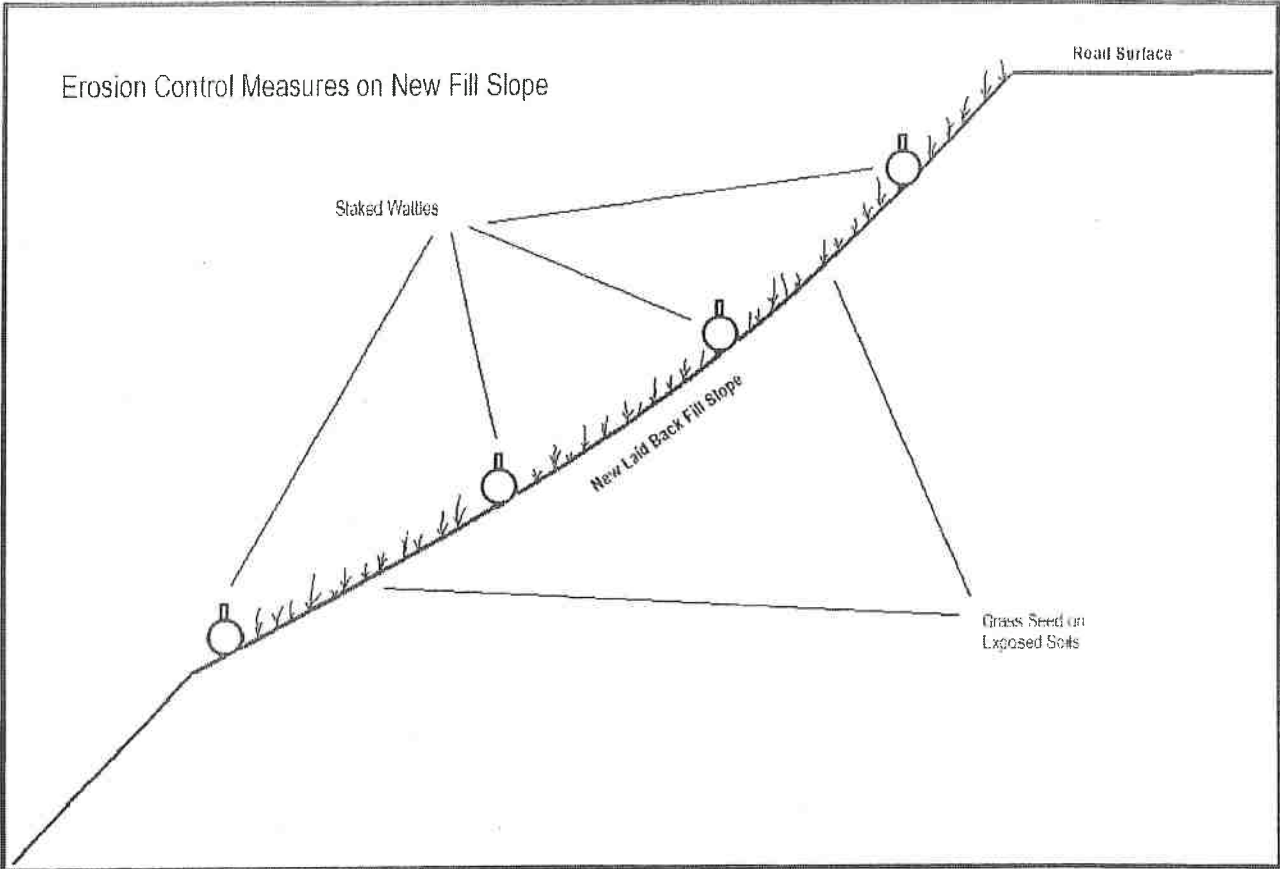
BMP: Unstable Fill Removal and Treatment



BMP: Unstable Fill Removal and Treatment



BMP: Unstable Fill Removal and Treatment



BMP: Rock Armor Cutbank



FIGURE 52. This wet and potentially unstable cut slope on a newly constructed road was stabilized using a buttress of large rock armor. To assure their effectiveness, rock buttresses and other retaining structures should be designed by a qualified engineer or engineering geologist.

HANDBOOK FOR FOREST, RANCH AND RURAL ROADS

BMP: Rip-Rap Size Class Table

TABLE 25. Standard classification and gradation of riprap by size of rock¹

Riprap size class	Median particle weight ²	Median particle diameter ² (in)	Minimum and maximum allowable particle size (in) ²						
			D ₁₅		D ₅₀		D ₈₅		D ₁₀₀
			Min	Max	Min	Max	Min	Max	Max
Class I	20 lb	6	3.7	5.2	5.7	6.9	7.8	9.2	12.0
Class II	60 lb	9	5.5	7.8	8.5	10.5	11.5	14.0	18.0
Class III	150 lb	12	7.3	10.5	11.5	14.0	15.5	18.5	24.0
Class IV	300 lb	15	9.2	13.0	14.5	17.5	19.5	23.0	30.0
Class V	¼ ton	18	11.0	15.5	17.0	20.5	23.5	27.5	36.0
Class VI	3/8 ton	21	13.0	18.5	20.0	24.0	27.5	32.5	42.0
Class VII	½ ton	24	14.5	21.0	23.0	27.5	31.0	37.0	48.0
Class VIII	1 ton	30	18.5	26.0	28.5	34.5	39.0	46.0	60.0
Class IX	2 ton	36	22.0	31.5	34.0	41.5	47.0	55.5	72.0
Class X	3 ton	42	25.5	36.5	40.0	48.5	54.5	64.5	84.0

¹Lagasse et al. (2006)

²Equivalent to spherical diameter

BMP: Storage Bladders

- Storage bladders shall be located and designed to minimize the potential for impacts due to rolling and/or failure. Storage bladders should be stored on flat slopes where stability will not be affected.
- Storage bladders shall be located to minimize the potential for water to flow into a watercourse in the event of a catastrophic failure.
- Bladders shall not be used unless the bladder is safely contained within a secondary containment system with sufficient capacity to capture 110 percent of a bladders maximum volume in the vent of bladder failure.
- Secondary containment is recommended in the form of a dirt berm, containment pit, combination of both, or impermeable material with skeletal support. The containment should be capable of holding 110 percent of the bladders volume.
- Secondary containment systems shall be of sufficient strength and stability to withstand the forces of released contents in the event of catastrophic bladder failure.
- Secondary containment systems that are exposed to precipitation shall be designed and maintained with sufficient capacity to accommodate precipitation and storm water inputs from a 25-year, 24-hour storm event.
- Bladders and containment systems shall be periodically inspected to ensure integrity.



This is an example of a containment pit which will assist in mitigating the impacts if this storage bladder failed.

BMP: Cultivation Site Restoration

- Remove all cultivation and associated materials from designated cultivation site.
 - This includes plant mass, root balls, potting containers, cultivation medium and any materials associated with the preparation, cultivation, and harvest of commercial cannabis.
 - Cultivation medium removed from the site shall be stored/disposed of in compliance with Order conditions related to spoils management.
- All disturbed and/or unstable slopes shall be stabilized and returned to pre-project conditions.
 - Slopes shall be contoured as close as feasible to natural grade and aspect.
 - Temporary erosion control shall be applied to prevent sediment run-off.
- Soil exposed as a result of project work, soil above rock riprap, and interstitial spaces between rocks shall be revegetated with native species by live planting, seed casting, or hydroseeding prior to the rainy season of the year work is completed.
 - Native plants characteristic of the local habitat shall be used for revegetation when implementing and maintaining cleanup/restoration work in riparian and other sensitive areas.
 - Native forbes and graminoids shall be planted to replace sediment stabilization, sediment filtration and nutrient filtration
 - Native trees and shrubs shall be planted to replace bank stabilization, inputs of large woody debris and temperature control within riparian areas.
 - Restoration of the quality/health of the riparian stand shall promote: 1) shade and microclimate controls; 2) delivery of wood to channels, 3) slope stability and erosion control, 4) ground cover, and 5) removal of excess nutrients.

BMP: Generator, Fuel, and Oil Management (General Requirements and Used Oil and Oil Filters)

All bulk fuel storage or petroleum products, any/all future petroleum products and other liquid chemicals, including but not limited to diesel, biodiesel, gasoline, and oils shall be stored so as to prevent their spillage, discharge, or seepage into receiving waters. Storage tanks and containers shall be of suitable material and construction to be compatible with the substance(s) stored and conditions of storage such as pressure and temperature. Above ground storage tanks and containers shall be provided with a secondary means of containment for the entire capacity of the largest single container and sufficient cover shall be provided to prevent any/all precipitation from entering said secondary containment vessel.

If the volume of a fuel container is greater than 1,320 gallons, a Spill Prevention, Control, and Countermeasures (SPCC) plan will be required for the use the fuel tank.

On-site storage of petroleum products, or other fuels used for commercial activities may require registration as hazardous materials through the California Environmental Reporting System (CERS). Additionally, the waste oil generated from commercial activities (generators) and their used oil filters are considered hazardous waste and requires addition reporting. The discharger is advised to contact local agencies to find out if such reporting is applicable to currently operations

Used motor oil is required to be stored in sealed containers that the oil was originally packaged in, e.g. sealed buckets/quart or gallon jugs, or other sealed containers designed to store motor oil. Stored used oil is required to be regularly disposed of at hazardous waste disposal sites. Used oil filters are also required to be stored in sealed containers, e.g. sealed plastic totes/buckets, for later disposal at a hazardous waste disposal site. These storage containers are required to be stored in structures where they are protected from precipitation.

Further information regarding the State of California's requirements for the managing of Used Oil and Oil Filters can be found by entering the links below or searching the corresponding titles to the links.

California Department of Toxic Substances Control - Used Oil Generator Requirements

- <https://www.dtsc.ca.gov/InformationResources/upload/RAG-UsedOilforGenerators.pdf>

Department of Toxic Substances Control - Managing Used Oil Filters for Generator

- https://www.dtsc.ca.gov/InformationResources/upload/RAG_Used-Oil-Filters_Generators1.pdf

BMP: Generator, Fuel, and Oil Management (Generators and Pumps)

All generators and petroleum powered pumps are required to have spill trays or secondary containment placed underneath them when using, fueling, or changing oil on them to prevent the potential for leeching, seepage or spillage of petroleum products. All spill trays and containment structures require cover from precipitation. All generators and petroleum powered pump locations are also required to have spill cleanup kits on hand.

Pre-fabricated secondary containment structures and spill trays can be purchased online or from local wholesalers of petroleum products. As an alternative to pre-fabricated secondary containment structures, structures can be constructed from wooden, cinderblock, concrete, or metal frames lined with PVC liners, e.g. pond liner/water bladder material, as long as the containment is fully sealed and constructed in a similar manner to examples of pre-fabricated containment structures found below. Ensure that diked areas are sufficiently impervious to contain discharged chemicals. All containment structures require cover from precipitation to prevent the containment from filling with water. Secondary containment for fuel tanks shall not be constructed.

As an alternative to pre-fabricated spill kits, kits can consist of sealed trashcans or buckets with industrial absorbent material (e.g. cat litter) and shovels, placed nearby any location where generators, pumps, or other petroleum products or chemicals are used.

Examples of industry standard pre-fabricated spill containment and clean-up kits can be found following or entering the links below. Pre-fabricated spill containment and clean-up kits can be purchased online, from Renner Petroleum, or other similar industry providers.

Ultratech Spill Containment

- <http://www.spillcontainment.com/categories/spill-containment/>

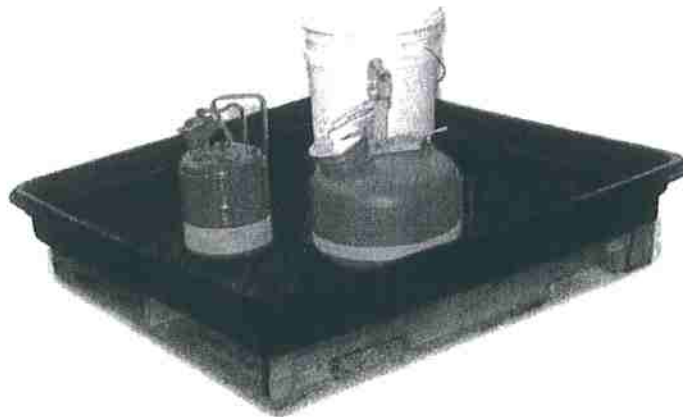
New Pig Portable and Collapsible Spill Containment

- <https://www.newpig.com/collapsible-berms/c/5142?show=All>

BMP: Generator, Fuel, and Oil Management

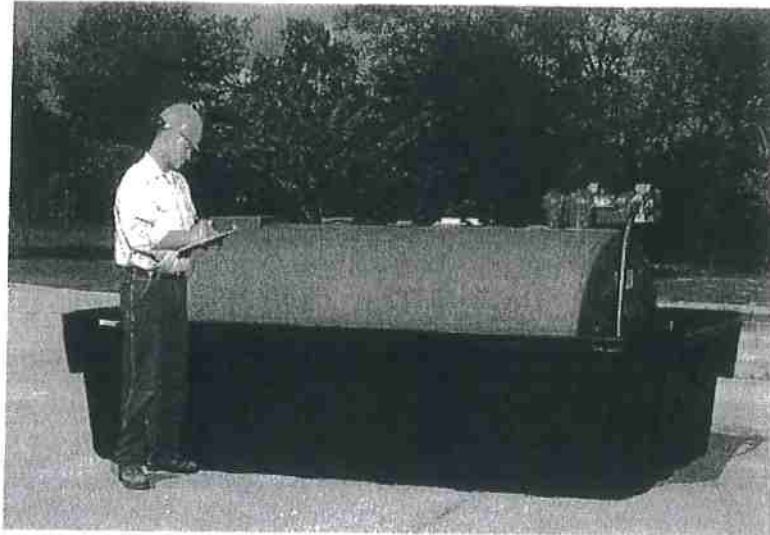


Example of a small, portable, and compact containment berm.



Example of a portable utility spill tray.

BMP: Generator, Fuel, and Oil Management



Example of secondary containment for a fuel tank. This container requires cover from precipitation.



Example of spill pallets for unused or used oil drums and other petroleum products.

WDID: _____

Date: _____

Monthly Water Tracking



Month	Total Surface Water Diversion	Water input to Storage by Source	Water use by Source
January			
February			
March			
April			
May			
June			
July			
August			
September			
October			
November			
December			

WDID: _____
Date: _____

Monthly Water Tracking



Monitoring Plan

Cannabis cultivators shall regularly inspect and maintain the condition of access roads, access road drainage features, and watercourse crossings. At a minimum, cannabis cultivators shall perform inspections prior to the onset of fall and winter precipitation and following storm events that produce at least 0.5 in/day or 1.0 inch/7 days of precipitation. See Required Monitoring tables below for site specific monitoring and reporting requirements. Cannabis cultivators are required to perform all of the following maintenance:

- Remove any wood debris that may restrict flow in a culvert.
- Remove sediment that impacts access road or drainage feature performance.
- Place any removed sediment in a location outside the riparian setbacks and stabilize the sediment.
- Maintain records of access road and drainage feature maintenance for annual reporting.

Cannabis cultivators that are operating in areas that are, or may become, inaccessible during winter months due to extreme weather such as snow, road closures, seasonal access roads to the property, or any other such conditions shall make additional efforts to enhance winterization measures in the absence of monitoring during storm events.

Monitoring Requirements

(Tier 1, High Risk, < 1 acre of cultivation)

Monitoring Requirement	Description
Winterization Measures Implemented	Report winterization procedures implemented, any outstanding measures, and the schedule for completion.
Tier Status Confirmation	Report any changes in the tier status.
Third Party Identification	Report any change in third party status as appropriate.

Annual Reporting

Annual Reports shall be submitted to the North Coast Regional Water Quality Control Board by March 1st following the year being monitored. The first Annual Report for this enrollment shall be submitted by March 1st, 2020 and report on monitoring done during the 2019 calendar year. Annual reporting is required each subsequent year of enrollment.

Attachments

Implementation of Applicable BPTC Measures

Assessment of applicable BPTC measures consisted of a field examination on March 19, 2018. Anywhere applicable BPTC measures are not met on the property, descriptions of the assessments and the prescribed treatments are outlined following each associated section below.

Summary of BPTC Measures Compliance

1. Sediment Discharge BPTC Measures Y/N
2. Fertilizer, Pesticide, Herbicide, and Rodenticide BPTC Measures Y/N
3. Petroleum Product BPTC Measures Y/N
4. Trash/Refuse, and Domestic Wastewater BPTC Measures Y/N
5. Winterization BPTC Measures Y/N

1. Sediment Discharge BPTC Measures

1.1. Site Characteristics

- 1.1.1. Provide a map showing access roads, vehicle parking areas, streams, stream crossings, cultivation site(s), disturbed areas, buildings, and other relevant site features.

See attached Site Map.

- 1.1.2. Describe the access road conditions including estimating vehicle traffic, road surface (e.g., paved, rocked, or bare ground), and maintenance activities. Describe how storm water is drained from the access road (e.g., crowned, out slope, armored ditch, culverts, rolling dips, etc.).

Roads are being classified as "permanent" (roads appurtenant to the project being used year-round), "seasonal" (roads appurtenant to the project being used primarily during summer months), and "foot trail" (being used for regular or occasional access to features on the property).

Roads within the project area appear to have a moderate to low native rock component and, based on observations of surface erosion relative to current surface drainage break frequency, are being classified as having moderate erodibility. Currently, all roads on the property have native surfaces.

Roads assessed by TRC were found to be in inadequate condition with native surfacing and lack adequate rock surfacing and drainage features to allow surface/ditch-line water drainage. Crooked Prairie/West Fork Road (Sites 01 to Site 09) lacks adequate drainage features and a functioning ditch-line. This is resulting in concentrated road surface

runoff eroding the road surface. Ditch flows are also jumping the inside ditch at this location. Runoff is either traveling down the road surface into the watercourse crossing at Site 01, or it is draining onto the property access road between Site 04 and 05 where it is eroding the access road (Site 11) and discharging into surface waters at Site 16. Wheel ruts were observed at two locations (Sites 06 & 19) on access roads on the date of the site visit.

Currently, two employees utilize the access road approximately regularly during the cultivation season. The access road is not used regularly during the Winter Period as there is no year-round residence.

- 1.1.3. Describe any vehicle stream crossing including the type of crossing (e.g., bridge, culvert, low water, etc.).

See the section titled "Stream Crossing Installation and Maintenance" or the attached Mitigation Report and Site Maps for site specific details and treatment schedules.

- 1.1.3.1. For Region 1 Dischargers, identify, discuss, and locate on the site map any legacy waste discharge issues that exist on the property.

Not applicable. No legacy waste discharge issues were identified during the assessment of the property.

- 1.2. Sediment Erosion Prevention and Sediment Capture (Moderate risk Tier 1 or Tier 2 Dischargers are required to submit a Site Erosion and Sediment Control Plan. Those Dischargers may refer to that plan rather than repeat it here)

1.2.1. Erosion Prevention BPTC Measures

- 1.2.1.1. Describe the BPTC measures that have been, or will be implemented to prevent or limit erosion. Provide an implementation schedule for BPTC measures that have not yet been implemented. Identify the erosion prevention BPTC measures on a site map.

See the attached Mitigation Report, Site Maps, and Treatment Implementation Schedule for site specific descriptions, treatments, and the implementation schedule.

- 1.2.1.1.1. The description shall address physical BPTC measures, (e.g., placement of straw mulch, plastic covers, slope stabilization, soil binders, culvert outfall armoring, etc.) and biological BPTC measures (vegetation preservation/replacement, hydro seeding, etc.).

See sections "Land Development and Maintenance, Erosion Control, and Drainage Features" and "Riparian and Wetland Protection and Management" above, and the attached

Mitigation Report and BMPs for descriptions of physical and biological BPTC measures being prescribed.

1.2.2. Sediment Control BPTC Measures

- 1.2.2.1. Describe the BPTC measures that have been, or will be implemented to capture sediment that has been eroded. Provide an implementation schedule for BPTC measures that have not yet been implemented. Identify the sediment control BPTC measures on a site map.

See the attached Mitigation Report, Site Maps, and Treatment Implementation Schedule for site specific descriptions, treatments, and the implementation schedule.

- 1.2.2.1.1. The description shall address physical BPTC measures, (e.g., placement of silt fences, fiber rolls, or settling ponds/areas, etc.) and biological BPTC measures (vegetated outfalls, hydro seeding, etc.).

See sections "Land Development and Maintenance, Erosion Control, and Drainage Features" and "Riparian and Wetland Protection and Management" above, and the attached Mitigation Report and BMPs for descriptions of physical and biological BPTC measures being prescribed.

1.2.3. Maintenance Activities - Erosion Prevention and Sediment Control

- 1.2.3.1. Describe how the erosion prevention and sediment control BPTC measures will be monitored and maintained to protect water quality.

Erosion prevention BPTC measures and all corresponding work shall be inspected prior to and in conjunction with winter monitoring, as described above under the "Monitoring Plan" to ensure proper placement, installation, and function remain intact prior to and throughout the Winter Period.

- 1.2.3.2. Describe how any captured sediment will be either stabilized in place, excavated and stabilized on-site, or removed from the site.

Any significant captured sediment behind the wattles at Sites 05, 15, & 20 shall be seeded and straw mulched. If the wattles become backfilled with debris and begin to overtop, they shall be cleared out. This debris from the wattles shall be contoured into the grass hillside downslope, away from any surface runoff. The wattles shall be replaced if they have degraded to the point that they no longer function as intended. Captured sediment by drainage features elsewhere on the property will be allowed to stabilize and vegetate in place.

1.2.4. Erosion control BPTC measures: Describe the interim soil stabilization, if applicable and long-term BPTC measures implemented to prevent sediment transport at each identified disturbed area(s) and improperly constructed features.

See sections “Land Development and Maintenance, Erosion Control, and Drainage Features” and “Riparian and Wetland Protection and Management” above, and the attached Mitigation Report and BMPs for descriptions of physical and biological BPTC measures being prescribed.

2. Fertilizer, Pesticide, Herbicide, and Rodenticide BPTC Measures

2.1. Provide a summary table that identifies the products used at the site, when they are delivered to the site, how they are stored, and used at the site. If products are not consumed during the growing season, describe how they are removed from the site or stored to prevent discharge over the winter season.

See comprehensive table under 2.3

2.2. Provide a site map that locates storage locations.

See attached Site Map. Fertilizers are currently stored improperly around fertilizer mixing tanks at Site 11 and Site 30.

2.3. Describe how bulk fertilizers and chemical concentrates are stored, mixed, applied, and how empty containers are disposed.

Fertilizer, Pesticides, and Herbicide Products used on Site

Product	Delivery and Storage	On-site usage	How removed or stored
Ohrstroms’s maxicrop Liquid Seaweed	Brought to site in May of 2018. Stored around fertilizer mixing tanks.	Mixed into tank with water. It is then hand watered to individual plants as needed.	Stored around mixing tanks. Empty containers are left around mixing tanks.
Organic Gem Liquid Fish Fertilizer	Brought to site in May of 2018. Stored around fertilizer mixing tanks.	Mixed into tank with water. It is then hand watered to individual plants as needed.	Stored around mixing tanks. Empty containers are left around mixing tanks.
Botanicare CAL-MAG Plus Plant Supplement	Brought to site in May of 2018. Stored around fertilizer mixing tanks.	Mixed into tank with water. It is then hand watered to individual plants as needed.	Stored around mixing tanks. Empty containers are left around mixing tanks.
Cutting Edge Solution’s Sugaree	Brought to site in May of 2018. Stored around fertilizer mixing tanks.	Mixed into tank with water. It is then hand watered to individual plants as needed.	Stored around mixing tanks. Empty containers are left around mixing tanks.
Sparetime Supply’s Archipelago Bat Guano	Brought to site in May of 2018. Stored around fertilizer mixing tanks.	Mixed into tank with water. It is then hand watered to individual plants as needed.	Stored around mixing tanks. Empty containers are left around mixing tanks.
Lost Coast Plant Therapy	Brought to site in May of 2018. Stored around fertilizer mixing tanks.	Mixed into tank with water. It is then hand watered to	Stored around mixing tanks. Empty containers

		individual plants as needed.	are left around mixing tanks.
Vital Garden Supply's Baseline Granular Humus	Brought to site in May of 2018. Stored around fertilizer mixing tanks.	Mixed into tank with water. It is then hand watered to individual plants as needed.	Stored around mixing tanks. Empty containers are left around mixing tanks.

2.4. Describe procedures for spill prevention and cleanup.

Fertilizer, pesticides, and herbicide products will either be stored in a purpose-built structure or within other secured structures over winter. The cannabis cultivator shall obtain adequate quantities of absorbent materials and ensure that they are stored at all locations where the materials above are used, stored, or mixed. Should a spill of these materials occur, absorbent materials will be applied immediately and allowed enough time to absorb as much material as possible. Following treatment, absorbent materials applied will be removed and disposed of appropriately as per the manufacturer's guidelines

3. Petroleum Product BPTC Measures

3.1. Provide a summary table that identifies the products used at the site, when they are delivered to the site, how they are stored, and used at the site. If products are not consumed during the growing season, describe how they are removed from the site or stored to prevent discharge over the winter season.

See comprehensive table under 3.3.

3.2. Provide a site map that locates storage locations.

See attached Site Map. (See Structures and Sites 13, 23, & 28.

3.3. Describe how fuels, lubricants, and other petroleum products are stored, mixed, applied, and empty containers are disposed.

Petroleum Products

Products used on site	When they are delivered to site	How they are stored and used	How removed or stored
Gasoline	Brought to site when needed throughout the year.	Stored in standard 5-gallon gasoline canisters in an uncontained manner around the property. Used to fuel equipment.	Stored in standard 5-gallon gasoline canisters in an uncontained manner around the property.
Diesel	Brought to site when needed throughout the year.	Stored in two 500-gallon steel fuel tanks without secondary containment and without cover from precipitation. Used to fuel a generator.	Stored in two 500-gallon steel fuel tanks without secondary containment and without cover from precipitation.

Motor oil	Brought to site when needed throughout the year.	Stored alongside the 500-gallon steel fuel tanks and the generators. Used to lubricate internal combustion engines.	After oil changes, the used motor oil is stored in either the container it came in or in a sealed 55-gallon barrel for later disposal at an appropriate waste disposal facility.
-----------	--	---	--

3.4. Describe procedures for spill prevention and cleanup.

Any/all fuel canisters and motor oil containers shall be stored in secondary containment (e.g. plastic totes or sealed metal boxes) while being stored long term or not in immediate use, wherever these materials are used anywhere on the property. Adequate quantities of absorbent materials are stored at all locations where these types of materials are used, stored, or mixed. Should a spill of these materials occur, absorbent materials will be applied immediately and allowed enough time to absorb as much material as possible. Following treatment, absorbent materials applied as well as any contaminated soil will be removed and disposed of appropriately for the spilled material.

4. Trash/Refuse, and Domestic Wastewater BPTC Measures

4.1. Describe the types of trash/refuse that will be generated at the site. Describe how the material is contained and properly disposed of.

Domestic and commercial cannabis trash and refuse will be generated at the site. The trash/refuse is stored inadequately around the cultivation areas, structures, and generally around the property prior to disposal at an appropriate waste disposal facility.

4.1.1. Provide a site map that locates the trash/refuse storage locations.

Trash and refuse are stored inadequately around mapped cultivation areas and structures. Trash and refuse are also stored in the utility trailer is at Site 16. See attached the Mitigation Report and Site Map.

4.2. Describe the number of employees, visitors, or residents at the site.

There are two regular employees who are at the site during the cultivation season. Additional employees are brought onto the property for short periods of time to complete projects requiring additional employees. Visitors are occasionally on site, including consultants and regulatory agencies.

4.2.1. Describe the types of domestic wastewater generated at the site (e.g., household generated wastewater or chemical toilet).

Domestic sewage and wastewater (greywater) are generated on site.

4.2.2. Describe how the domestic wastewater is disposed.

Domestic sewage is disposed via an outhouse. Greywater from seasonally used travel trailers, the residence, and outdoor sinks is disposed of nearby where it is generated and allowed to infiltrate.

4.2.2.1. Permitted onsite wastewater treatment system (e.g., septic tank and leach lines).

Not applicable yet. The cannabis cultivation intends to obtain a permitted onsite wastewater treatment system.

4.2.2.2. Chemical toilets or holding tank. If so, provide the name of the servicing company and the frequency of service.

Not applicable yet. The cannabis cultivator intends to obtain portable chemical toilets as needed during the cultivation season.

4.2.2.3. Outhouse, pit privy, or similar. Use of this alternative requires approval from the Regional Water Board Executive Officer; include the approval from the Executive Officer and any conditions imposed for use of this alternative.

One outhouse was found on the property during the site assessment. The cannabis cultivator intends to discontinue and remove the outhouse and obtain portable chemical toilets as needed during the cultivation season.

4.2.2.3.1. Provide a site map that locates any domestic wastewater treatment, storage, or disposal area.

See attached Site Map for locations of structures and the outhouse (Adjacent to Site 20).

5. Winterization BPTC Measures

- 5.1. Describe activities that will be performed to winterize the site and prevent discharges of waste. The description should address all the issues listed above.

See Mitigation Report and Annual Winterization Measures for prescribed general winterization measures that will be performed prior to each Winter Period, and site-specific interim measures that will be performed prior to the Winter Period until permanent, prescribed treatments can be executed.

- 5.2. Describe maintenance of all drainage or sediment capture features (e.g., drainage culverts, drainage trenches, settling ponds, etc.) to remove debris, soil blockages, and ensure adequate capacity exists.

Existing drainage structures will be maintained or repaired as feasible and necessary with hand tools during annual winterization and winter monitoring. Prescribed repair and maintenance will be executed in accordance with the Mitigation Report and Treatment Implementation Schedules.

- 5.3. Describe any revegetation activities that will occur either at the beginning or end of the precipitation season.

See attached Mitigation Report and Treatment Implementation Schedule above.

- 5.4. If any BPTC measure cannot be completed before the onset of Winter Period, contact the Regional Water Board to establish a compliance schedule.

See the attached Mitigation Report and Treatment Implementation Schedule for site descriptions, treatments, and the implementation schedule.

- 5.5. For Region 1 Dischargers, describe any activities that will be performed to address legacy waste discharge issues. Region 6 Dischargers should consult with Regional Water Board staff to confirm if any other activities in addition to BPTCs are necessary to address legacy waste discharge issues.

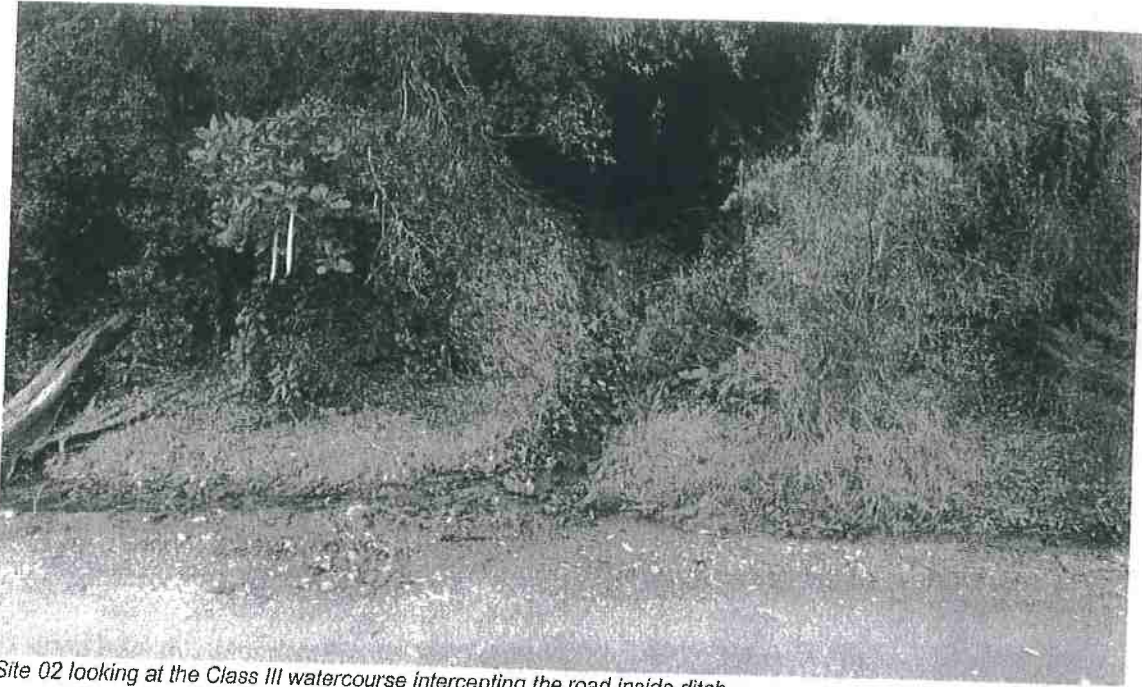
Not applicable. No legacy waste discharge issues were identified during the assessment of the property.



Site 01 looking up grade (Southeast).



Site 01 looking down grade (Northwest).



Site 02 looking at the Class III watercourse intercepting the road inside ditch.



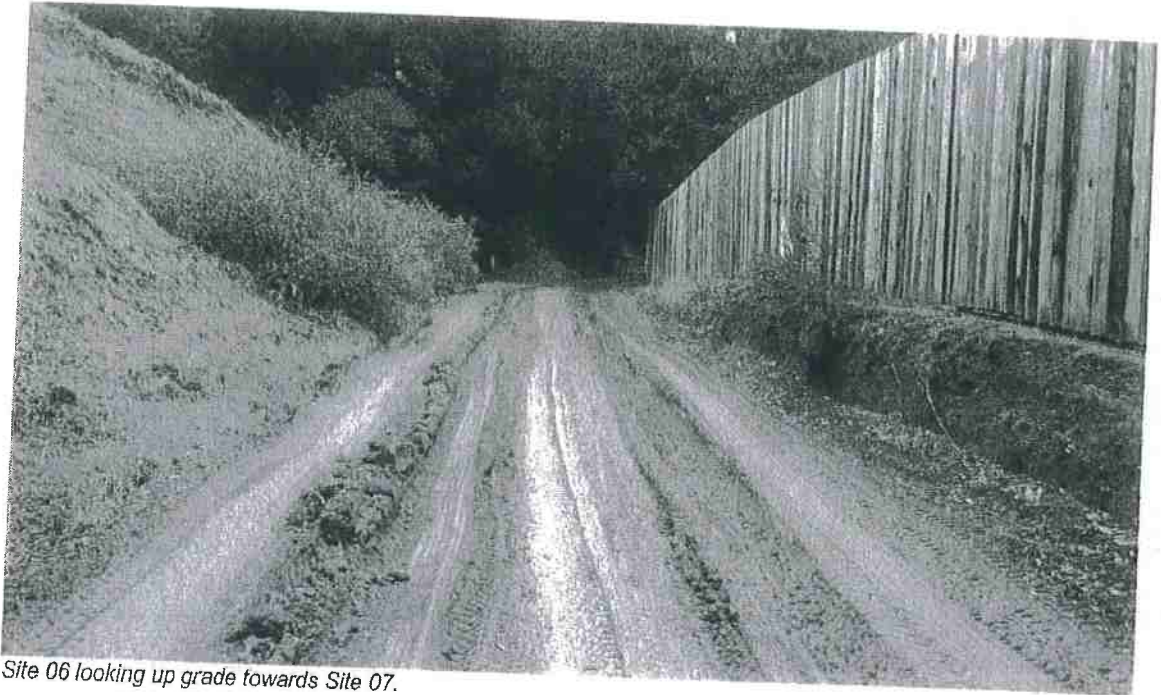
Site 02 looking down grade to Site 01.



Site 04 looking up grade.



Site 05 looking down grade. Some concentrated road surface runoff is draining off of the road under the gate to the left and contributing to road surface erosion and discharge at Sites 10 and 15.



Site 06 looking up grade towards Site 07.



Site 07 looking down grade at Site 06.



Site 08 looking up grade.



Site 09 looking up grade.



Site 16 looking down grade to Site 10. Notice concentrated road surface runoff intercepting front of utility trailer and also bypassing the trailer to the left of the photo.



Looking down grade from Site 10 to Site 15. Note edge of the soil pile and other cultivation-related wastes in the upper left hand corner of the photo at Site 14.



Looking down grade at Site 15 and the nursery greenhouse within riparian setbacks.



Looking up grade from Site 15.



Site 19 looking up grade towards Site 18. Note rutting, concentrated road surface runoff, and the disturbed area/removed cultivation area, to the upper left. Also, in the photo that is difficult to discern is the cultivation-related soils and perlite on the road surface and removed cultivation area.



Site 19 looking down grade towards Site 20. The runoff from this site reaches Site 20. Site 20 is just out of frame, to the right-hand side of the photograph.



Site 19 looking up grade towards Site 18. Note rutting, concentrated road surface runoff, and the disturbed area/removed cultivation area, to the upper left. Also, in the photo that is difficult to discern is the cultivation-related soils and perlite on the road surface and removed cultivation area.



Site 19 looking down grade towards Site 20. The runoff from this site reaches Site 20. Site 20 is just out of frame, to the right-hand side of the photograph.