

COUNTY OF HUMBOLDT

AGENDA ITEM NO.
C22

For the meeting of January 9, 2018

Date: December 4, 2017
To: Board of Supervisors
From:  Thomas K. Mattson, Director of Public Works
Subject: Williams Creek Bridge Replacement on Grizzly Bluff Road; Project Number BRLS 5904(127); Contract Number 594209

RECOMMENDATION(S):

That the Board of Supervisors:

1. Approve the plans and specifications for the Williams Creek Bridge Replacement on Grizzly Bluff Road.
2. Direct the Clerk of the Board to advertise the above-mentioned project as required by Section 22037 of the California Public Contract Code with bids to be opened on February 13, 2018, at 2:00 p.m.

SOURCE OF FUNDING:

Road Fund-Federal Highway Administration Highway Bridge Program (HBP)



DISCUSSION:

The Williams Creek Bridge on Grizzly Bluff Road is a forty (40) foot long, single span concrete T-beam structure with concrete abutments. The bridge was constructed in 1920. It is located about one-half mile east of the City of Ferndale, California, and provides access across Williams Creek for farmers and local

Prepared by Jeff Ball CAO Approval 

REVIEW: Auditor  County Counsel  Human Resources  Other _____

TYPE OF ITEM:
 Consent
 Departmental
 Public Hearing
 Other _____

BOARD OF SUPERVISORS, COUNTY OF HUMBOLDT
Upon motion of Supervisor  Seconded by Supervisor 
Ayes 
Nays _____
Abstain _____
Absent _____

PREVIOUS ACTION/REFERRAL:

Board Order No. _____
Meeting of: _____

and carried by those members present, the Board hereby approves the recommended action contained in this Board report.

Dated: 1/9/18
By: 
Kathy Hayes, Clerk of the Board

residents travelling between Rio Dell and Ferndale. The existing bridge has extensive cracking in the abutments, wing-walls and concrete railing due to settlement and errant vehicles. The bridge is eligible for replacement as indicated in the California Department of Transportation's August 24, 2011, bridge inspection report.

On March 25, 2014, the Board of Supervisors executed a bridge design services contract with Mark Thomas and Company to develop plans and specifications for bridge replacement. The project has progressed through environmental approval, design of plans and specifications, estimate development, right of way certification, and Federal Highway Administration's authorization to proceed with construction on November 30, 2017.

The work to be done, in general, includes demolition of the existing concrete bridge, installation of a temporary detour, temporary stream diversion, constructing a new bridge and road approaches, grading, erosion control, paving, roadway striping, revegetation monitoring, and other items required by the plans and specifications. Bridge construction is expected to take one hundred and twenty-five (125) working days to complete, or about six (6) months and the revegetation monitoring will continue for five (5) years after the project is completed.

The Department of Public Works recommends that the Board of Supervisors approves the attached plans and specifications, advertise the project, and proceed to construction.

FINANCIAL IMPACT:

There is no financial commitment until the project is awarded. The Federal Highway Administration Highway Bridge Program provides 88.53% of funding and the county road fund will cover the remaining 11.47% of the project costs. The Engineer's Estimate for the construction contract is \$1,894,819. Construction costs were included in the Fiscal Year 2017-18 Road Fund Budget.

This project conforms to the Board of Supervisors' Core Role of providing for and maintaining infrastructure as identified in the Board's Strategic Framework. This item has no impact on the General Fund.

OTHER AGENCY INVOLVEMENT:

California Department of Transportation
Federal Highway Administration

ALTERNATIVES TO STAFF RECOMMENDATIONS:

Not approve the project; however, staff does not recommend this alternative as this project will replace an existing structurally deficient and functionally obsolete bridge with a new bridge that will serve the current and future needs of the Ferndale community.

ATTACHMENT:

Plans and Specifications for the Williams Creek Bridge Replacement on Grizzly Bluff Road, Project Number BRLS 5904 (127), Contract Number 594209

County of Humboldt • Department of Public Works
1106 Second Street • Eureka • CA • 95501 • (707) 445-7652



SPECIAL PROVISIONS

**NOTICE TO CONTRACTORS,
PROPOSAL AND CONTRACT**

FOR

**WILLIAMS CREEK BRIDGE REPLACEMENT ON GRIZZLY
BLUFF ROAD**

**PROJECT NO.: BRLS-5904(127)
CONTRACT NO.: 594209**

125 WORKING DAYS

**FOR USE WITH Standard Specifications dated 2010,
Standard Plans dated 2010, Prevailing Wage Rates,
Labor Surcharge and Equipment Rental Rates**

BIDS OPEN: FEBRUARY 13, 2018 AT 2:00 PM

**Clerk of the Board's Office
Humboldt County Courthouse
825 Fifth Street, Suite 111
Eureka, CA 95501**

SPECIAL PROVISIONS

NOTICE TO CONTRACTORS,
PROPOSAL AND CONTRACT

FOR
WILLIAMS CREEK BRIDGE REPLACEMENT ON GRIZZLY BLUFF ROAD

PROJECT NO.: BRLS-5904(127)
CONTRACT NO.: 594209

Prepared for

County of Humboldt
Department of Public Works
1106 Second Street
Eureka, CA 95501

Recommended:



Zachary J. Siviglia
RCE 73128, Expires 12/31/2018

12/8/18
Date

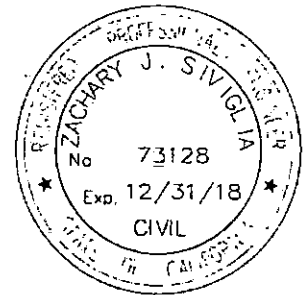

Jason B. Hickey
RSE S5783, Expires 06/30/2018

12/8/18
Date

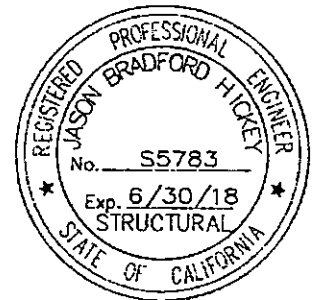

TABLE OF CONTENTS

NOTICE TO BIDDERS	5
SPECIAL PROVISIONS	7
DIVISION I GENERAL PROVISIONS.....	7
1 GENERAL.....	7
2 BIDDING	8
3 CONTRACT AWARD AND EXECUTION	10
5 CONTROL OF WORK.....	13
6 CONTROL OF MATERIALS	16
7 LEGAL RELATIONS AND RESPONSIBILITY TO THE PUBLIC.....	16
8 PROSECUTION AND PROGRESS	38
9 PAYMENT.....	38
DIVISION II GENERAL CONSTRUCTION.....	42
10 GENERAL.....	42
12 TEMPORARY TRAFFIC CONTROL.....	42
13 WATER POLLUTION CONTROL	44
14 ENVIRONMENTAL STEWARDSHIP	50
15 EXISTING FACILITIES	55
DIVISION III GRADING.....	57
19 EARTHWORK.....	57
20 LANDSCAPE.....	58
21 EROSION CONTROL	59
DIVISION IV SUBBASES AND BASES.....	60
26 AGGREGATE BASES.....	60
DIVISION V SURFACING AND PAVEMENTS.....	60
39 HOT MIX ASPHALT.....	60
DIVISION VI STRUCTURES.....	61
48 TEMPORARY STRUCTURES	61
DIVISION IX TRAFFIC CONTROL FACILITIES.....	62
80 FENCES	62
83 RAILINGS AND BARRIERS	62
PROPOSAL.....	64
BID FORM (EXHIBIT A) (PAGE 1)	66
BID FORM (EXHIBIT A) (PAGE 2)	67
PROPOSAL SIGNATURE PAGE.....	68
BIDDER'S BOND	69
CONTRACTOR'S CERTIFICATE REGARDING WORKER'S COMPENSATION	70
EXHIBIT 12-B BIDDER'S LIST OF SUBCONTRACTORS (DBE AND NON-DBE) - PART I.....	71
EXHIBIT 12-B BIDDER'S LIST OF SUBCONTRACTORS (DBE AND NON-DBE) - PART II	72
EXHIBIT 15-G LOCAL AGENCY BIDDER DBE COMMITMENT (CONSTRUCTION CONTRACTS)	73
EXHIBIT 15-H DBE INFORMATION—GOOD FAITH EFFORTS	75
PUBLIC CONTRACT CODE SECTION 10285.1 STATEMENT	77
PUBLIC CONTRACT CODE SECTION 10162 QUESTIONNAIRE.....	77
PUBLIC CONTRACT CODE SECTION 10232 STATEMENT	77
DEBARMENT AND SUSPENSION CERTIFICATION.....	78
EQUAL EMPLOYMENT OPPORTUNITY CERTIFICATION.....	79
NONCOLLUSION AFFIDAVIT	80
CERTIFICATION FOR FEDERAL AID CONTRACTS (LOBBYING ACTIVITIES).....	81
DISCLOSURE OF LOBBYING ACTIVITIES	82
FINAL REPORT – UTILIZATION OF DISADVANTAGED BUSINESS ENTERPRISES	84

EXHIBIT 17-O: DISADVANTAGED BUSINESS ENTERPRISES (DBE) CERTIFICATION STATUS CHANGE..... 85
AGREEMENT 86
PAYMENT BOND 90
PERFORMANCE BOND 91

STANDARD PLANS LIST

The standard plan sheets applicable to this Contract include those listed below. The applicable revised standard plans (RSPs) listed below are included in the project plans.

	ABBREVIATIONS, LINES, SYMBOLS AND LEGEND
A10A	Abbreviations (Sheet 1 of 2)
RSP 10B	Abbreviations (Sheet 2 of 2)
A10C	Lines and Symbols (Sheet 1 of 3)
A10D	Lines and Symbols (Sheet 2 of 3)
A10E	Lines and Symbols (Sheet 3 of 3)
RSP 10F	Legend - Soil (Sheet 1 of 2)
RSP 10G	Legend - Soil (Sheet 2 of 2)
A10H	Legend - Rock
	PAVEMENT MARKERS, TRAFFIC LINES, AND PAVEMENT MARKINGS
A20A	Pavement Markers and Traffic Lines, Typical Details
A20B	Pavement Markers and Traffic Lines, Typical Details
RSP 24C	Pavement Markings - Symbols and Numerals
	EXCAVATION AND BACKFILL
A62A	Excavation and Backfill - Miscellaneous Details
A62B	Limits of Payment for Excavation and Backfill - Bridge Surcharge and Wall
A62C	Limits of Payment for Excavation and Backfill - Bridge
	OBJECT MARKERS, DELINEATORS, CHANNELIZERS AND BARRICADES
A73A	Object Markers
A73B	Markers
A73C	Delineators, Channelizers and Barricades
	SURVEY MONUMENTS
A74	Survey Monuments
	MIDWEST GUARDRAIL SYSTEM STANDARD RAILING SECTIONS
RSP	Midwest Guardrail System Standard Railing Section (Wood Post with Wood Block)
A77L1	Midwest Guardrail System Standard Hardware
RSP	
A77M1	Midwest Guardrail System Wood Post and Wood Block Details
RSP	
A77N1	Midwest Guardrail System Typical Line Post Embedment and Hinge Point Offset Details
RSP	
A77N3	Midwest Guardrail System Typical Railing Delineation and Dike Positioning Details
RSP	
A77N4	
	MIDWEST GUARDRAIL SYSTEM TYPICAL LAYOUTS FOR STRUCTURES
RSP	Midwest Guardrail System Typical Layouts for Structure Approach
A77Q1	
RSP	Midwest Guardrail System Typical Layouts for Structure Approach and Between Structures
A77Q2	
RSP	Midwest Guardrail System Typical Layouts for Structure Departure
A77Q4	
RSP	Midwest Guardrail System Typical Layouts for Structure Departure
A77Q5	
	MIDWEST GUARDRAIL SYSTEM END ANCHORAGE AND RAIL TENSIONING ASSEMBLY
RSP	Midwest Guardrail System End Anchor Assembly (Type SFT)
A77S1	

**MIDWEST GUARDRAIL SYSTEM CONNECTION DETAILS AND
TRANSITION RAILING TO BRIDGE RAILINGS, ABUTMENTS AND
WALLS**

RSP	Midwest Guardrail System Connections to Bridge Railings without
A77U1	Sidewalks Details No. 1
RSP	Midwest Guardrail System Connections to Bridge Railings without
A77U2	Sidewalks Details No. 2
RSP	Midwest Guardrail System Transition Railing (Type WB-31)
A77U4	
RSP	Midwest Guardrail System Transition to Metal Beam Guardrail
A77U5	

THRIE BEAM BARRIER - STANDARD BARRIER SECTIONS

RSP	Thrie Beam Barrier - Standard Barrier Railing Section (Wood Post
A78A	with Wood Block)
A78C1	Thrie Beam Barrier - Standard Hardware Details
RSP	Thrie Beam Barrier - Post and Block Details
A78C2	

ABUTMENTS, WALLS AND BARRIER

A78F2	Single Thrie Beam Barrier - Connections to Bridge Railings without
	Sidewalks
	FENCES

A86	Barbed Wire and Wire Mesh Fences
A86A	Barbed Wire and Wire Mesh Fence Detail on Sharp Break in Grade
A86B	Barbed Wire and Wire Mesh Fence Details
A86C	Barbed Wire and Wire Mesh Fence Details at Ditch Crossing
RSP	Barbed Wire and Wire Mesh Fence - Miscellaneous Details
A86D	

**TEMPORARY CRASH CUSHIONS, RAILING AND TRAFFIC
SCREEN**

T1A	Temporary Crash Cushion, Sand Filled (Unidirectional)
T1B	Temporary Crash Cushion, Sand Filled (Bidirectional)
T2	Temporary Crash Cushion, Sand Filled (Shoulder Installations)
T3A	Temporary Railing (Type K)
T3B	Temporary Railing (Type K)

TEMPORARY WATER POLLUTION CONTROL

T51	Temporary Water Pollution Control Details (Temporary Silt Fence)
T53	Temporary Water Pollution Control Details (Temporary Cover)
T54	Temporary Water Pollution Control Details (Temporary Erosion
	Control Blanket)
T55	Temporary Water Pollution Control Details (Temporary Erosion
	Control Blanket)
T56	Temporary Water Pollution Control Details (Temporary Fiber Roll)
T57	Temporary Water Pollution Control Details (Temporary Check Dam)
T58	Temporary Water Pollution Control Details (Temporary
	Construction Entrance)
T59	Temporary Water Pollution Control Details (Temporary Concrete
	Washout Facility)

BRIDGE DETAILS

B0-1	Bridge Details
------	----------------

JOINT SEALS

RSP B6-	Joint Seals (Maximum Movement Rating = 2")
21	

CAST-IN-PLACE POST-TENSIONED GIRDER

RSP B8-5	Cast-In-Place Post-Tensioned Girder Details
RSP B11-	Concrete Barrier Type 80 (Sheet 1 of 2)
60	

B11-61

Concrete Barrier Type 80 (Sheet 2 of 2)

BRIDGE METAL RAIL BARRIERS

ROADSIDE SIGNS

RS1

Roadside Signs, Typical Installation Details No. 1

RS2

Roadside Signs - Wood Post, Typical Installation Details No. 2

RS4

Roadside Signs, Typical Installation Details No. 4



COUNTY OF HUMBOLDT
DEPARTMENT OF PUBLIC WORKS

NOTICE TO BIDDERS

Sealed proposals will be received by (and all bids should be mailed or delivered to) the

Clerk of the Board Office
SEALED BID for (Project Name)
Humboldt County Courthouse
825 Fifth Street, Suite 111
Eureka, California, 95501

until 2:00 PM, **TUESDAY, FEBRUARY 13, 2018**, at which time they will be publicly opened by the Clerk of the Board of the County of Humboldt at a public meeting in the Office of the Clerk of the Board of Supervisors, Humboldt County Courthouse, Eureka, California, for performing work as follows:

WILLIAMS CREEK BRIDGE REPLACEMENT ON GRIZZLY BLUFF ROAD
PROJECT NO.: BRLS-5904(127)
CONTRACT NO.: 594209

Bids are required for the entire work as described herein:

The bridge work to be done, in general, includes constructing a new bridge and road approaches; grading; paving; applying signing, erosion control, culverts, and other items and details, not mentioned above, that are required by the plans, specifications or these Special Provisions for the bridge listed below. Bidders are advised that the work must be completed within **125 working days**. The Engineer's Estimate for this work is: **\$1,894,819**.

Plans, Special Provisions (not including documents included by reference) and Proposal Forms may be obtained by prospective Bidders upon **ADVANCE** payment of a non-refundable printing and service charge in the amount of **\$15.00**. All checks shall be made payable to COUNTY OF HUMBOLDT and should be mailed along with the request for Plans to the Humboldt County Department of Public Works, 1106 Second Street, Eureka, California, 95501.

Telephone: (707) 445-7652 Requests for plans, planholder list or project estimate
(707) 445-7377 Engineering division, questions regarding plans or specs
(707) 445-7409 Fax transmissions

Plans and Special Provisions reference the Caltrans Standard Specifications and Standard Plans dated 2010. Provisions that reference federal-aid contracts are applicable.

The successful Bidder shall furnish a Payment Bond and a Performance Bond.

The Contractor shall possess a **CLASS "A"** Contractors License at the time this contract is awarded.

No pre-bid meeting is scheduled for this project.

This contract is subject to state contract nondiscrimination and compliance requirements pursuant to Government Code, Section 12990. The County of Humboldt affirms that in any contract entered into pursuant to this advertisement, Disadvantaged Business Enterprises, as defined in 49 CFR Part 26, will be afforded full opportunity to submit bids in response to this invitation.

For this contract, the County has included a Disadvantaged Business Enterprises (DBE) goal of **10 Percent**. Bidders need not achieve the percentage stated as a condition of award.

Inquiries or questions based on alleged patent ambiguity of the plans, specifications or estimate must be communicated as a bidder inquiry prior to bid opening. Any such inquiries or questions, submitted after bid opening, will not be treated as a bid protest.

Pursuant to Section 1773 of the Labor Code, the general prevailing wage rates in the county, or counties, in which the work is to be done have been determined by the Director of the California Department of Industrial Relations. These wages are set forth in the General Prevailing Wage Rates for this project, available at County of Humboldt, 1106 2nd Street, Eureka, CA. 95501 and available from the California Department of Industrial Relations' Internet web site at <http://www.dir.ca.gov/DLSR/PWD>. The Federal minimum wage rates for this project as predetermined by the United States Secretary of Labor are available on the web home page of the Department of Labor at <http://www.gpo.gov/davisbacon/> and copies may be examined at the offices described above where project plans, special provisions, and proposal forms may be seen. Addenda to modify the Federal minimum wage rates, if necessary, will be issued to holders of "Special Provisions, Notice to Bidder's, Proposal and Contract" books. Future effective general prevailing wage rates which have been predetermined and are on file with the California Department of Industrial Relations are referenced but not printed in the general prevailing wage rates.

Attention is directed to the Federal minimum wage rate requirements of the Department of Labor. If there is a difference between the minimum wage rates predetermined by the Secretary of Labor and the general prevailing wage rates determined by the Director of the California Department of Industrial Relations for similar classifications of labor, the Contractor and subcontractors shall pay not less than the higher wage rate. The Department will not accept lower State wage rates not specifically included in the Federal minimum wage determinations. This includes "helper" (or other classifications based on hours of experience) or any other classification not appearing in the Federal wage determinations. Where Federal wage determinations do not contain the State wage rate determination otherwise available for use by the Contractor and subcontractors, the Contractor and subcontractors shall pay not less than the Federal minimum wage rate which most closely approximates the duties of the employees in question.

For the Federal Trainee Program, the number of trainees, and apprentices, is 2.

This project is subject to the "Buy America" provisions of the Surface Transportation Act of 1982 as amended by the Intermodal Surface Transportation Efficiency Act of 1991 (ISTEA) Sections 1041(a) and 1048(a), and the regulations adopted pursuant thereto.

The U.S. Department of Transportation (DOT) provides a toll-free "hotline" service to report bid rigging activities. Bid rigging activities can be reported Mondays through Fridays, between 8:00 a.m. and 5:00 p.m., eastern time, Telephone No. 1-800-424-9071. Anyone with knowledge of possible bid rigging, bidder collusion, or other fraudulent activities should use the "hotline" to report these activities. The "hotline" is part of the DOT's continuing effort to identify and investigate highway construction contract fraud and abuse and is operated under the direction of the DOT Inspector General. All information will be treated confidentially and caller anonymity will be respected.

KATHY HAYES

Clerk of the Board of Supervisors
County of Humboldt, State of California

DATED: _____



COUNTY OF HUMBOLDT
DEPARTMENT OF PUBLIC WORKS

**SPECIAL PROVISIONS
FOR**

**WILLIAMS CREEK BRIDGE REPLACEMENT ON GRIZZLY BLUFF ROAD
PROJECT NO.: BRLS-5904(127)
CONTRACT NO.: 594209**

DIVISION I GENERAL PROVISIONS

1 GENERAL

Add to section 1-1.01:

The work embraced herein shall be done in accordance with the **STANDARD SPECIFICATIONS dated 2010**, and the **STANDARD PLANS dated 2010**, and revisions thereto, of the State of California, Department of Transportation insofar as the same may apply and in accordance with the following special provisions. In case of conflict between the Standard Specifications and these special provisions, the special provisions shall take precedence over and be used in lieu of such conflicting portions.

Add to section 1-1.07A:

Whenever the following terms are used in the Standard Specifications, the following County departments or persons shall be intended and substituted therefore:

STATE: County of Humboldt, a political subdivision of the State of California.

DEPARTMENT, DIRECTOR: Humboldt County Department of Public Works.

ENGINEER: The Director of Public Works of Humboldt County or his authorized agent working within the scope of his authority.

LABORATORY: Materials and Testing Laboratory of the Humboldt County Department of Public Works.

WILLOW CUTTINGS FOR PLANT GROUP W: Willow Stakes.

^^

2 BIDDING

Add to section 2-1.06A:

Plans, Special Provisions (not including documents included by reference) and Proposal Forms may be viewed by prospective Bidders at the Humboldt County Department of Public Works, 1106 Second Street, Eureka California.

Plans, Special Provisions and Supplemental Project Information may be viewed on the County of Humboldt web site: www.co.humboldt.ca.us. Current Revised Standard Specifications are available for review at the Department of Public Works, 1106 Second Street, Eureka, or on Caltrans web page of the Office Engineer/ Engineering. (<http://www.dot.ca.gov/hq/esc/oe/standards.php>)

Note that Plans, Special Provisions, and Proposal Forms posted on the County's web site are for **informational purposes only and may not be substituted for any bid document**. Only those bid documents purchased from the Department of Public Works at 1106 Second Street, Eureka, California, 95501 may be used to submit a bid.

Replace section 2-1.12 with:

2-1.12 DISADVANTAGED BUSINESS ENTERPRISES (DBE)

Under 49 CFR 26.13(b):

The contractor, sub recipient or subcontractor shall not discriminate on the basis of race, color, national origin, or sex in the performance of this contract. The contractor shall carry out applicable requirements of 49 CFR part 26 in the award and administration of DOT-assisted contracts. Failure by the contractor to carry out these requirements is a material breach of this contract, which may result in the termination of this contract or such other remedy as the recipient deems appropriate.

Take necessary and reasonable steps to ensure that DBEs have opportunity to participate in the contract (49 CFR 26).

To ensure equal participation of DBEs provided in 49 CFR 26.5, the Agency shows a goal for DBEs.

Make work available to DBEs and select work parts consistent with available DBE subcontractors and suppliers.

Meet the DBE goal shown in the Notice to Bidders or demonstrate that you made adequate good faith efforts to meet this goal.

It is your responsibility to verify that the DBE firm is certified as DBE at date of bid opening. For a list of DBEs certified by the California Unified Certification Program, go to:

http://www.dot.ca.gov/hq/bep/find_certified.htm

All DBE participation will count toward the California Department of Transportation's federally mandated statewide overall DBE goal.

Credit for materials or supplies you purchase from DBEs counts towards the goal in the following manner:

1. 100 percent counts if the materials or supplies are obtained from a DBE manufacturer.
2. 60 percent counts if the materials or supplies are obtained from a DBE regular dealer.
3. Only fees, commissions, and charges for assistance in the procurement and delivery of materials or supplies count if obtained from a DBE that is neither a manufacturer or regular dealer. 49 CFR 26.55 defines "manufacturer" and "regular dealer."

You receive credit towards the goal if you employ a DBE trucking company that performs a commercially useful function as defined in 49 CFR 26.55(d)(1) through (4) and (6).

DBE Commitment Submittal

Submit DBE information on the Caltrans Bidder - DBE - Commitment form included in the Bid book. If the form is not submitted with the bid, remove the form from the Bid book before submitting your bid.

If the DBE Commitment form is not submitted with the bid, the apparent low bidder, the 2nd low bidder, and the 3rd low bidder must complete and submit the DBE Commitment form to Office Engineer. DBE Commitment form must be received by the Agency no later than 4:00 p.m. on the 4th business day after bid opening.

Other bidders do not need to submit the DBE Commitment form unless the Agency requests it. If the Agency requests you to submit a DBE Commitment form, submit the completed form within 4 business days of the request.

Submit written confirmation from each DBE stating that it is participating in the contract. Include confirmation with the DBE Commitment form. A copy of a DBE's quote will serve as written confirmation that the DBE is participating in the contract.

If you do not submit the DBE Commitment form within the specified time, the Agency finds your bid nonresponsive.

Good Faith Efforts Submittal

If you have not met the DBE goal, complete and submit the Good Faith Efforts Documentation form with the bid showing that you made adequate good faith efforts to meet the goal. Only good faith efforts directed towards obtaining participation by DBEs will be considered. If good faith efforts documentation is not submitted with the bid, it must be received by the Agency no later than 4:00 p.m. on the 4th business day after bid opening.

If your DBE Commitment form shows that you have met the DBE goal or if you are required to submit the DBE Commitment form, you must also submit good faith efforts documentation within the specified time to protect your eligibility for award of the contract in the event the Agency finds that the DBE goal has not been met.

Good faith efforts documentation must include the following information and supporting documents, as necessary:

1. Items of work you have made available to DBE firms. Identify those items of work you might otherwise perform with its own forces and those items that have been broken down into economically feasible units to facilitate DBE participation. For each item listed, show the dollar value and percentage of the total contract. It is your responsibility to demonstrate that sufficient work to meet the goal was made available to DBE firms.
2. Names of certified DBEs and dates on which they were solicited to bid on the project. Include the items of work offered. Describe the methods used for following up initial solicitations to determine with certainty if the DBEs were interested, and the dates of the follow-up. Attach supporting documents such as copies of letters, memos, facsimiles sent, telephone logs, telephone billing statements, and other evidence of solicitation. You are reminded to solicit certified DBEs through all reasonable and available means and provide sufficient time to allow DBEs to respond.
3. Name of selected firm and its status as a DBE for each item of work made available. Include name, address, and telephone number of each DBE that provided a quote and their price quote. If the firm selected for the item is not a DBE, provide the reasons for the selection.
4. Name and date of each publication in which you requested DBE participation for the project. Attach copies of the published advertisements.
5. Names of agencies and dates on which they were contacted to provide assistance in contacting, recruiting, and using DBE firms. If the agencies were contacted in writing, provide copies of supporting documents.
6. List of efforts made to provide interested DBEs with adequate information about the plans, specifications, and requirements of the contract to assist them in responding to a solicitation. If you have provided information, identify the name of the DBE assisted, the nature of the information provided, and date of contact. Provide copies of supporting documents, as appropriate.
7. List of efforts made to assist interested DBEs in obtaining bonding, lines of credit, insurance, necessary equipment, supplies, and materials, excluding supplies and equipment that the DBE subcontractor purchases or leases from the prime contractor or its affiliate. If such assistance is provided by you, identify the name of the DBE assisted, nature of the assistance offered, and date assistance was provided. Provide copies of supporting documents, as appropriate.
8. Any additional data to support demonstration of good faith efforts.

The Agency may consider DBE commitments of the 2nd and 3rd bidders when determining whether the low bidder made good faith efforts to meet the DBE goal.

Add to section 2-1.33C:

The form "Subcontractor List" is included in the Proposal Section of these special provisions.

Add to section 2-1.34:

The form "Bidder's Security" will be found following the signature page of the Proposal.

^^

3 CONTRACT AWARD AND EXECUTION

Add to section 3-1.04:

Bid Protest. Any bid protest must be in writing and must be received by the Department Director at 1106 Second Street, Eureka, CA, 95501 (Fax: (707) 445-7409), before 5:00 p.m. no later than three (3) working days following bid opening (the "Bid Protest Deadline") and must comply with the following requirements:

1. Only a bidder who has actually submitted a Bid Proposal is eligible to submit a bid protest against another bidder. Subcontractors are not eligible to submit bid protests. A bidder may not rely on the bid protest submitted by another bidder, but must timely pursue its own protest.

2. The bid protest must contain a complete statement of the basis for the protest and all supporting documentation. Material submitted after the Bid Protest Deadline will not be considered. The protest must refer to the specific portion or portions of the Contract Documents upon which the protest is based. The protest must include the name, address and telephone number of the person representing the protesting bidder if different from the protesting bidder.

3. A copy of the protest and all supporting documents must also be transmitted by fax or by e-mail, by or before the Bid Protest Deadline, to the protested bidder and any other bidder who has a reasonable prospect of receiving an award depending upon the outcome of the protest.

4. The protested bidder may submit a written response to the protest, provided the response is received by the Department Director before 5:00 p.m., within two (2) working days after the Bid Protest Deadline or after receipt of the bid protest, whichever is sooner (the "Response Deadline"). The response must include all supporting documentation. Material submitted after the Response Deadline will not be considered. The response must include the name, address and telephone number of the person representing the protested bidder if different from the protested bidder.

5. The procedure and time limits set forth in this section are mandatory and are the bidder's sole and exclusive remedy in the event of bid protest. The bidder's failure to comply with these procedures shall constitute a waiver of any right to further pursue a bid protest, including filing a Government Code Claim or initiation of legal proceedings.

Any addenda or bulletins issued during the time of bidding, or forming a part of the documents issued to the Bidder for the preparation of his bid, shall be covered in the bid, and shall become a part of the Agreement.

No person, firm or corporation shall be allowed to make or file, or be interested in, more than one bid for the same work, unless alternate bids are called for. A person, firm, or corporation who has submitted a subproposal to a Bidder, or who has quoted prices on materials to a Bidder, is not thereby disqualified from submitting a subproposal or quoting prices to other Bidders.

Replace section 3-1.05:

The successful Bidder, simultaneously with the execution of the Agreement, will be required to furnish a **Payment Bond** in an amount equal to **one hundred (100%) percent** of the contract price, and a **faithful Performance Bond** in an amount equal to **one hundred (100%)** of the contract price; said Bonds shall be secured from a surety company satisfactory to the Humboldt County Board of Supervisors. The Payment Bond shall comply with Section 3248 of the Civil Code of the State of California. The Payment Bond and the faithful Performance Bond shall each be in a form which is satisfactory to the County Counsel of the County of Humboldt. A copy of an acceptable format is attached to the Agreement forms included in the proposal section of these specifications.

Replace section 3-1.07:

I. THIS CONTRACT/AGREEMENT SHALL NOT BE EXECUTED BY COUNTY and the CONTRACTOR is not entitled to any rights, unless certificates of insurance, or other sufficient proof that the following provisions have been complied with, and such certificate(s) are filed with the Clerk of the Humboldt County Board of Supervisors.

II. Without limiting Contractor's indemnification provided herein, Contractor shall and shall require any of its subcontractors to take out and maintain, throughout the period of this Agreement, the following policies of insurance placed with insurers with a current A.M. Bests rating of no less than A:VII or its equivalent against injury/death to persons or damage to property which may arise from or in connection with the activities hereunder of Contractor, its agents, employees or subcontractors:

A. Comprehensive or Commercial General Liability Insurance at least as broad as Insurance Services Office Commercial General Liability coverage (occurrence from CG 0001), in an amount of \$1,000,000 per occurrence. If work involves explosive, underground or collapse risks, XCU must be included. If a general aggregate limit is used, either the general aggregate limit shall apply separately to this project or the general aggregate shall be twice the required occurrence limit. Said policy shall contain, or be endorsed with, the following provisions:

(1) The County, its officers, employees and agents, are covered as additional insured for liability arising out of the operations performed by or on behalf of Contractor. The coverage shall contain no special limitations on the scope of protection afforded to the County, its officers, agents, and employees.

(2) The policy shall not be canceled or materially reduced in coverage without thirty (30) days prior written notice (10 days for non-payment of the premium) to County by certified mail.

(3) The inclusion of more than one insured shall not operate to impair the rights of one insured against another insured, and the coverage afforded shall apply as though separate policies had been issued to each insured, but the inclusion of more than one insured shall not operate to increase the limits of the insurer's liability.

(4) For claims related to this project, the Contractor's insurance is primary coverage to the County, and any insurance or self-insurance programs maintained by the County are excess to Contractor's insurance and will not be called upon to contribute with it.

(5) Any failure to comply with reporting or other provisions of the parties, including breach of warranties, shall not affect coverage provided to County, its officers, employees, and agents.

B. Automobile liability insurance with coverage at least as broad as Insurance Services Office form CA 0001 06092, Code 1 (any auto), for vehicles used in the performance of this Agreement with minimum coverage of not less than \$1,000,000 per accident combined single limit (CSL). Such policy shall contain or be endorsed with the provision that coverage shall not be canceled or materially reduced in coverage without thirty(30) days prior written notice (10 days for non-payment of premium) to County by certified mail.

C. Workers' Compensation insurance meeting statutory limits of the California Labor Code which policy shall contain or be endorsed to contain a waiver of subrogation against County, its officers, agents, and employees and provide for thirty (30) days prior written notice in the event of cancellation.

D. Contractor shall furnish County with certificates and original endorsements effecting the required coverage prior to execution of this Agreement by County. The endorsements shall be on forms as approved by the County's Risk Manager or County Counsel. Any deductible or self-insured retention over \$100,000 shall be disclosed to and approved by County. If Contractor does not keep all required policies in full force and effect, County may, in addition to other remedies under this Agreement, take out the necessary insurance, and Contractor agrees to pay the cost of said insurance.

The County may elect to treat a failure to maintain the requisite insurances as a breach of contract/agreement and terminate the contract/agreement as provided herein.

6. Listed DBE is ineligible to work on the project because of suspension or debarment.
7. Listed DBE becomes bankrupt or insolvent.
8. Listed DBE voluntarily withdraws with written notice from the Contract
9. Listed DBE is ineligible to receive credit for the type of work required.
10. Listed DBE owner dies or becomes disabled resulting in the inability to perform the work on the Contract.
11. Agency determines other documented good cause.

Notify the original DBE of your intent to use other forces or material sources and provide the reasons. Provide the DBE with 5 days to respond to your notice and advise you and the Agency of the reasons why the use of other forces or sources of materials should not occur. Your request to use other forces or material sources must include:

1. 1 or more of the reasons listed in the preceding paragraph
2. Notices from you to the DBE regarding the request
3. Notices from the DBEs to you regarding the request

If a listed DBE is terminated, make good faith efforts to find another DBE to substitute for the original DBE. The substitute DBE must perform at least the same amount of work as the original DBE under the contract to the extent needed to meet the DBE goal.

The substitute DBE must be certified as a DBE at the time of request for substitution.

Unless the Agency authorizes (1) a request to use other forces or sources of materials or (2) a good faith effort for a substitution of a terminated DBE, the Agency does not pay for work listed on the Caltrans Bidder - DBE - Commitment form unless it is performed or supplied by the listed DBE or an authorized substitute.

Add to section 5-1.20B(1):

Permits obtained by the Department for this project include:

- U.S. Army Corps of Engineers
- North Coast Regional Water Quality Control Board
- California Coastal Commission
- California Department of Fish and Game

Add to section 5-1.36A:

Following removal of the temporary detour, Contractor must plant a cherry tree west of the Miranda Diary driveway, location as directed by the Engineer.

If Contractor stages operations in a potential staging area shown in the plans, place five strand barbed wire fencing around inner perimeter of easement area, and restore the staging site to pre-project conditions including the following:

- Rip and cross-rip site at a depth of 2.5', disc harrow and seed with a pasture mix. Pasture seed mix and application rate must be as directed by Engineer and may differ for each easement area.
- Replace chain link fence in kind west of Miranda Diary driveway if removed during construction.
- Replace five-strand barbed wire fencing in kind if removed during construction

- Protect black plastic water pipe in place, and repair or replace upon completion of the project. Pipe is located on Hill property.

Payment for restoring staging areas to pre-project conditions and planting a cherry tree must be considered as included in the payment for Temporary Detour and no additional compensation will be allowed therefore.

Replace paragraph 3, section 5-1.36D:

The Contractor's attention is directed to the existence of certain underground facilities that may require special precautions be taken by the Contractor to protect the health, safety and welfare of workmen and of the public. Facilities requiring special precautions include, but are not limited to: conductors of petroleum products, oxygen, chlorine, and toxic or flammable gases; natural gas in pipelines greater than 150 mm (6 inches) in diameter or pipelines operating at pressures greater than 415 kPa (60 psi) gauge; underground electric supply system conductors or cables, with potential to ground of more than 300 volts, either directly buried or in duct or conduit which do not have concentric grounded conductors or other effectively grounded metal shields or sheaths.

Per Govt Code § 4216 et seq., the Contractor shall notify the Engineer and the appropriate regional notification center for operators of subsurface installations at least 3 working days, but not more than 14 calendar days, prior to performing any excavation or other work close to any underground pipeline, conduit, duct, wire or other structure. Regional notification centers include but are not limited to the following:

Notification Center	Telephone Number
Underground Service Alert-Northern California (USA)	1-800-642-2444 1-800-227-2600
Underground Service Alert-Southern California (USA)	1-800-422-4133 1-800-227-2600

Add to section 5-1.36D:

Installation of the utilities shown in the following table requires coordination with your activities. Make the necessary arrangements with the utility company through the Engineer and submit a schedule:

1. Verified by a representative of the utility company
2. Allowing at least the time shown for the utility owner to complete its work

Utility Relocation and Contractor-Arranged Time for the Relocation

Utility	Utility address	Location	Days
Frontier Communications	Contact: Marc Cate Ph#(541)808-7212 Frontier PO Box 535 Coos Bay, OR 97420	As shown in construction plans sheet 10 of 29	To be determined

The requirements of this section shall apply to materials furnished for the project, except for acquisition of materials in conformance with the provisions in section 4-1.04, "Use of Materials Found on the Job Site," of the Standard Specifications.

Add to section 7-1.11A:

During the performance of this Agreement, the contractor, for itself, its assignees and successors in interest (hereinafter collectively referred to as CONTRACTOR) agrees as follows:

- (1) Compliance with Regulations: CONTRACTOR shall comply with the regulations relative to nondiscrimination in federally assisted programs of the Department of Transportation, Title 49, Code of Federal Regulations, Part 21, as they may be amended from time to time, (hereinafter referred to as the REGULATIONS), which are herein incorporated by reference and made a part of this agreement.
- (2) Nondiscrimination: CONTRACTOR, with regard to the work performed by it during the AGREEMENT, shall not discriminate on the grounds of race, color, sex, national origin, religion, age, or disability in the selection and retention of sub-applicants, including procurements of materials and leases of equipment. CONTRACTOR shall not participate either directly or indirectly in the discrimination prohibited by Section 21.5 of the Regulations, including employment practices when the agreement covers a program set forth in Appendix B of the Regulations.
- (3) Solicitations for Sub-agreements, Including Procurements of Materials and Equipment: In all solicitations either by competitive bidding or negotiation made by CONTRACTOR for work to be performed under a Sub-agreement, including procurements of materials or leases of equipment, each potential sub-applicant or supplier shall be notified by CONTRACTOR of the CONTRACTOR'S obligations under this Agreement and the Regulations relative to nondiscrimination on the grounds of race, color, or national origin.
- (4) Information and Reports: CONTRACTOR shall provide all information and reports required by the Regulations, or directives issued pursuant thereto, and shall permit access to its books, records, accounts, other sources of information, and its facilities as may be determined by the California Department of Transportation or FHWA to be pertinent to ascertain compliance with such Regulations or directives. Where any information required of CONTRACTOR is in the exclusive possession of another who fails or refuses to furnish this information, CONTRACTOR shall so certify to the California Department of Transportation or the FHWA as appropriate, and shall set forth what efforts CONTRACTOR has made to obtain the information.
- (5) Sanctions for Noncompliance: In the event of CONTRACTOR'S noncompliance with the nondiscrimination provisions of this agreement, the California Department of Transportation shall impose such agreement sanctions as it or the FHWA may determine to be appropriate, including, but not limited to:
 - (a) withholding of payments to CONTRACTOR under the Agreement within a reasonable period of time, not to exceed 90 days; and/or
 - (b) cancellation, termination or suspension of the Agreement, in whole or in part.
- (6) Incorporation of Provisions: CONTRACTOR shall include the provisions of paragraphs (1) through (6) in every sub-agreement, including procurements of materials and leases of equipment, unless exempt by the Regulations, or directives issued pursuant thereto.

CONTRACTOR shall take such action with respect to any sub-agreement or procurement as the California Department of Transportation or FHWA may direct as a means of enforcing such provisions including sanctions for noncompliance, provided, however, that, in the event CONTRACTOR becomes involved in, or is threatened with, litigation with a sub-applicant or supplier as a result of such direction, CONTRACTOR may request the California Department of Transportation enter into such litigation to protect the interests of the State, and, in addition, CONTRACTOR may request the United States to enter into such litigation to protect the interests of the United States.

Add to section 7-1.11A:

The predetermined federal wages are derived from the Davis-Bacon Act of 1931 and are prescribed by 23 USC 113. The Federal Wage Rates are available directly from the Department of Labor at: <http://www.wdol.gov/dba.aspx#0>. The user is given a choice between entering in the determination number example: "CA2008004" or selecting the criteria State/County/Construction Type/WD number (WD num not needed). Select California/Humboldt/Highway, respectively. Copies of the Federal Wage Rates will also be available at:

Information Office
County of Humboldt, Department of Public Works
1106 Second Street
Eureka, CA 95501

Federal Wage Rates are not required to be physically included in this Bid Package. However, the federal wage rates as revised by addendums, if such addendums are issued, are included in the Agreement signed by the County of Humboldt and the Contractor.

Add to section 7-1.11A:

Federal lobbying restrictions imposed by Section 1352, Title 31, United States Code, is included in section 7-1.11B(XII).

A certification for Federal-aid contracts regarding payment of funds to lobby Congress or a Federal agency is included in the Proposal. Standard Form - LLL, "Disclosure of Lobbying Activities," with instructions for completion of the Standard Form is also included in the Proposal. Signing the Proposal shall constitute signature of the Certification.

The Contractor, subcontractors and any lower-tier contractors shall file a disclosure form at the end of each calendar quarter in which there occurs any event that requires disclosure or that materially affects the accuracy of the information contained in any disclosure form previously filed by the Contractor, subcontractors and any lower-tier contractors. An event that materially affects the accuracy of the information reported includes:

- (1) A cumulative increase of \$25,000 or more in the amount paid or expected to be paid for influencing or attempting to influence a covered Federal action; or
- (2) A change in the person(s) or individual(s) influencing or attempting to influence a covered Federal action; or
- (3) A change in the officer(s), employees(s), or Member(s) contacted to influence or attempt to influence a covered Federal Action.

Add to section 7-1.11A:

Use of United States-Flag Vessel

The contractor agrees -

- (1) To utilize privately owned United State flag commercial vessels to ship at least 50 percent of the gross tonnage (computed separately for dry bulk carriers, dry cargo liners, and tankers) involved, whenever shipping any equipment, material, or commodities pursuant to this contract, to the extent such vessels are available at fair and reasonable rates for United States-flag commercial vessels.
- (2) To furnish within 20 days following the date of loading for shipments originating within the United States or within 30 working days following the date, of loading for shipments originating outside the United States, a legible copy of a rated, 'on-board' commercial ocean bill-of-lading in English for each shipment of cargo described in paragraph (1) of this section to both the Contracting Officer (through the prime contractor in the case of subcontractor bills-of lading) and to the Division of National Cargo, Office of Market Development, Maritime Administration, Washington, DC 20590.
- (3) To insert the substance of the provisions of this clause in all subcontracts issued pursuant to this contract.

Add to section 7-1.11A:

FEDERAL REQUIREMENTS FOR FEDERAL-AID CONSTRUCTION PROJECTS

GENERAL.—The work herein proposed will be financed in whole or in part with Federal funds, and therefore all of the statutes, rules and regulations promulgated by the Federal Government and applicable to work financed in whole or in part with Federal funds will apply to such work. The "Required Contract Provisions, Federal-Aid Construction Contracts, "Form FHWA 1273, are included in this Section 14. Whenever in said required contract provisions references are made to "SHA contracting officer", "SHA resident engineer", or "authorized representative of the SHA", such references shall be construed to mean "Engineer" as defined in Section 1-1.18 of the Standard Specifications.

PERFORMANCE OF PREVIOUS CONTRACT.—In addition to the provisions in Section II, "Nondiscrimination," and Section VII, "Subletting or Assigning the Contract," of the required contract provisions, the Contractor shall comply with the following:

The bidder shall execute the CERTIFICATION WITH REGARD TO THE PERFORMANCE OF PREVIOUS CONTRACTS OR SUBCONTRACTS SUBJECT TO THE EQUAL OPPORTUNITY CLAUSE AND THE FILING OF REQUIRED REPORTS located in the proposal. No request for subletting or assigning any portion of the contract in excess of \$10,000 will be considered under the provisions of Section VII of the required contract provisions unless such request is accompanied by the CERTIFICATION referred to above, executed by the proposed subcontractor.

NON-COLLUSION PROVISION.—The provisions in this section are applicable to all contracts except contracts for Federal Aid Secondary projects.

Title 23, United States Code, Section 112, requires as a condition precedent to approval by the Federal Highway Administrator of the contract for this work that each bidder file a sworn statement executed by, or on behalf of, the person, firm, association, or corporation to whom such contract is to be awarded, certifying that such person, firm, association, or corporation has not, either directly or indirectly, entered into any agreement, participated in any collusion, or otherwise taken any action in restraint of free competitive bidding in connection with the submitted bid. A form to make the non-collusion affidavit statement required by Section 112 as a certification under penalty of perjury rather than as a sworn statement as permitted by 28, USC, Sec. 1746, is included in the proposal.

PARTICIPATION BY DISADVANTAGED BUSINESS ENTERPRISES IN SUBCONTRACTING.—Part 26, Title 49, Code of Federal Regulations applies to this Federal-aid project. Pertinent sections of said Code are incorporated in part or in its entirety within other sections of these special provisions.

Schedule B—Information for Determining Joint Venture Eligibility (This form need not be filled in if all joint venture firms are DBE owned.)

1. Name of joint venture _____

2. Address of joint venture _____

3. Phone number of joint venture _____

4. Identify the firms which comprise the joint venture. (The DBE partner must complete Schedule A.) _____

a. Describe the role of the DBE firm in the joint venture. _____

b. Describe very briefly the experience and business qualifications of each non-DBE joint venturer: _____

5. Nature of the joint venture's business _____

6. Provide a copy of the joint venture agreement.

7. What is the claimed percentage of DBE ownership? _____

8. Ownership of joint venture: (This need not be filled in if described in the joint venture agreement, provided by question

6.)

- a. Profit and loss sharing.
- b. Capital contributions, including equipment.
- c. Other applicable ownership interests.

Revised 3-95
08-07-95

FR-1

9. Control of and participation in this contract. Identify by name, race, sex, and "firm" those individuals (and their titles) who are responsible for day-to-day management and policy decision making, including, but not limited to, those with prime responsibility for:

a. Financial decisions _____

b. Management decisions, such as:

1. Estimating _____

2. Marketing and sales _____

3. Hiring and firing of management personnel _____

4. Purchasing of major items or supplies _____

c. Supervision of field operations _____

Note.—If, after filing this Schedule B and before the completion of the joint venture's work on the contract covered by this regulation, there is any significant change in the information submitted, the joint venture must inform the grantee, either directly or through the prime contractor if the joint venture is a subcontractor.

Affidavit

"The undersigned swear that the foregoing statements are correct and include all material information necessary to identify and explain the terms and operation of our joint venture and the intended participation by each joint venturer in the undertaking. Further, the undersigned covenant and agree to provide to grantee current, complete and accurate information regarding actual joint venture work and the payment therefor and any proposed changes in any of the joint venture arrangements and to permit the audit and examination of the books, records and files of the joint venture, or those of each joint venturer relevant to the joint venture, by authorized representatives of the grantee or the Federal funding agency. Any material misrepresentation will be grounds for terminating any contract which may be awarded and for initiating action under Federal or State laws concerning false statements."

Revised 3-95
08-07-95

FR-2

.....
Name of Firm	Name of Firm
.....
Signature	Signature
.....
Name	Name
.....
Title	Title
.....
Date	Date

Date _____
State of _____
County of _____

On this ___ day of _____, 19 __, before me appeared (Name) _____, to me personally known, who, being duly sworn, did execute the foregoing affidavit, and did state that he or she was properly authorized by (Name of firm) _____ to execute the affidavit and did so as his or her free act and deed.

Notary Public _____
Commission expires _____

[Seal]
Date _____
State of _____
County of _____

On this ___ day of _____, 19 __, before me appeared (Name) _____ to me personally known, who, being duly sworn, did execute the foregoing affidavit, and did state that he or she was properly authorized by (Name of firm) _____ to execute the affidavit and did so as his or her free act and deed.

Notary Public _____
Commission expires _____

[Seal]

Replace section 7-1.11B with:

FHWA-1273 – Revised May 1, 2012

**REQUIRED CONTRACT PROVISIONS
FEDERAL-AID CONSTRUCTION CONTRACTS**

- I. General
- II. Nondiscrimination
- III. Nonsegregated Facilities
- IV. Davis-Bacon and Related Act Provisions
- V. Contract Work Hours and Safety Standards Act Provisions
- VI. Subletting or Assigning the Contract
- VII. Safety: Accident Prevention
- VIII. False Statements Concerning Highway Projects
- IX. Implementation of Clean Air Act and Federal Water Pollution Control Act
- X. Compliance with Government wide Suspension and Debarment Requirements
- XI. Certification Regarding Use of Contract Funds for Lobbying

ATTACHMENTS

A. Employment and Materials Preference for Appalachian Development Highway System or Appalachian Local Access Road Contracts (included in Appalachian contracts only)

I. GENERAL

1. Form FHWA-1273 must be physically incorporated in each construction contract funded under Title 23 (excluding emergency contracts solely intended for debris removal). The contractor (or subcontractor) must insert this form in each subcontract and further require its inclusion in all lower tier subcontracts (excluding purchase orders, rental agreements and other agreements for supplies or services).

The applicable requirements of Form FHWA-1273 are incorporated by reference for work done under any purchase order, rental agreement or agreement for other services. The prime contractor shall be responsible for compliance by any subcontractor, lower-tier subcontractor or service provider.

Form FHWA-1273 must be included in all Federal-aid design-build contracts, in all subcontracts and in lower tier subcontracts (excluding subcontracts for design services, purchase orders, rental agreements and other agreements for supplies or services). The design-builder shall be responsible for compliance by any subcontractor, lower-tier subcontractor or service provider.

Contracting agencies may reference Form FHWA-1273 in bid proposal or request for proposal documents, however, the Form FHWA-1273 must be physically incorporated (not referenced) in all contracts, subcontracts and lower-tier subcontracts (excluding purchase orders, rental agreements

and other agreements for supplies or services related to a construction contract).

2. Subject to the applicability criteria noted in the following sections, these contract provisions shall apply to all work performed on the contract by the contractor's own organization and with the assistance of workers under the contractor's immediate superintendence and to all work performed on the contract by piecework, station work, or by subcontract.

3 A breach of any of the stipulations contained in these Required Contract Provisions may be sufficient grounds for withholding of progress payments, withholding of final payment, termination of the contract, suspension / debarment or any other action determined to be appropriate by the contracting agency and FHWA

4 Selection of Labor During the performance of this contract, the contractor shall not use convict labor for any purpose within the limits of a construction project on a Federal-aid highway unless it is labor performed by convicts who are on parole, supervised release, or probation The term Federal-aid highway does not include roadways functionally classified as local roads or rural minor collectors

II. NONDISCRIMINATION

The provisions of this section related to 23 CFR Part 230 are applicable to all Federal-aid construction contracts and to all related construction subcontracts of \$10,000 or more The provisions of 23 CFR Part 230 are not applicable to material supply, engineering, or architectural service contracts

In addition, the contractor and all subcontractors must comply with the following policies Executive Order 11 246, 41 CFR 60, 29 CFR 1625-1627, Title 23 USC Section 140, the Rehabilitation Act of 1 973, as amended (29 USC 794), Title VI of the Civil Rights Act of 1964, as amended, and related regulations including 49 CFR Parts 21, 26 and 27, and 23 CFR Parts 200, 230, and 633

The contractor and all subcontractors must comply with: the requirements of the Equal Opportunity Clause in 41 CFR 60-1.4(b) and, for all construction contracts exceeding \$10,000, the Standard Federal Equal Employment Opportunity Construction Contract Specifications in 41 CFR 60-4.3.

Note The U S Department of Labor has exclusive authority to determine compliance with Executive Order 11246 and the policies of the Secretary of Labor including 41 CFR 60, and 29 CFR 1625-1627 The contracting agency and the FHWA have the authority and the responsibility to ensure compliance with Title 23 USC Section 140, the Rehabilitation Act of 1973, as

amended (29 USC 794), and Title VI of the Civil Rights Act of 1964, as amended, and related regulations including 49 CFR Parts 21, 26 and 27, and 23 CFR Parts 200, 230, and 633

The following provision is adopted from 23 CFR 230, Appendix

A, with appropriate revisions to conform to the U S Department of Labor (US DOL) and FHWA requirements.

1. Equal Employment Opportunity: Equal employment opportunity (EEO) requirements not to discriminate and to take affirmative action to assure equal opportunity as set forth under laws, executive orders, rules, regulations (28 CFR 35, 29 CFR 1630, 29 CFR 1625-1627, 41 CFR 60 and 49 CFR 27) and orders of the Secretary of Labor as modified by the provisions prescribed herein, and imposed pursuant to 23 U.S.C. 140 shall constitute the EEO and specific affirmative action standards for the contractor's project activities under this contract. The provisions of the Americans with Disabilities Act of 1990 (42 U.S.C. 12101 et seq.) set forth under 28 CFR 35 and 29 CFR 1630 are incorporated by reference in this contract. In the execution of this contract, the contractor agrees to comply with the following minimum specific requirement activities of EEO:

a. The contractor will work with the contracting agency and the Federal Government to ensure that it has made every good faith effort to provide equal opportunity with respect to all of its terms and conditions of employment and in their review of activities under the contract.

b. The contractor will accept as its operating policy the following statement:

"It is the policy of this Company to assure that applicants are employed, and that employees are treated during employment, without regard to their race, religion, sex, color, national origin, age or disability. Such action shall include: employment, upgrading, demotion, or transfer; recruitment or recruitment advertising; layoff or termination; rates of pay or other forms of compensation; and selection for training, including apprenticeship, pre-apprenticeship, and/or on-the-job training.

2. EEO Officer: The contractor will designate and make known to the contracting officers an EEO Officer who will have the responsibility for and must be capable of effectively administering and promoting an active EEO program and who must be assigned adequate authority and responsibility to do so.

3. Dissemination of Policy: All members of the contractor's staff who are authorized to hire, supervise, promote, and discharge employees, or who recommend such action, or who are substantially involved in such action, will be made fully cognizant of, and will implement, the contractor's EEO policy and contractual responsibilities to provide EEO in each grade and classification of employment. To ensure that the above agreement will be met, the following actions will be taken as a minimum:

a. Periodic meetings of supervisory and personnel office employees will be conducted before the start of work and then not less often than once every six months, at which time the contractor's EEO policy and its implementation will be reviewed and explained. The meetings will be conducted by the EEO Officer.

b. All new supervisory or personnel office employees will be given a thorough indoctrination by the EEO Officer, covering all major aspects of the contractor's EEO obligations within thirty days following their reporting for duty with the contractor.

c. All personnel who are engaged in direct recruitment for the project will be instructed by the EEO Officer in the contractor's procedures for locating and hiring minorities and women.

d. Notices and posters setting forth the contractor's EEO policy will be placed in areas readily accessible to employees, applicants for employment and potential employees.

e. The contractor's EEO policy and the procedures to implement such policy will be brought to the attention of employees by means of meetings, employee handbooks, or other appropriate means.

4. Recruitment: When advertising for employees, the contractor will include in all advertisements for employees the notation: "An Equal Opportunity Employer." All such advertisements will be placed in publications having a large circulation among minorities and women in the area from which the project work force would normally be derived.

a. The contractor will, unless precluded by a valid bargaining agreement, conduct systematic and direct recruitment through public and private employee referral sources likely to yield qualified minorities and women. To meet this requirement, the contractor will identify sources of potential minority group employees, and establish with such identified sources procedures whereby minority and women applicants may be referred to the contractor for employment consideration.

b. In the event the contractor has a valid bargaining agreement providing for exclusive hiring hall referrals, the contractor is expected to observe the provisions of that agreement to the extent that the system meets the contractor's compliance with EEO contract provisions. Where implementation of such an agreement has the effect of discriminating against minorities or women, or obligates the contractor to do the same, such implementation violates Federal nondiscrimination provisions.

c. The contractor will encourage its present employees to refer minorities and women as applicants for employment. Information and procedures with regard to referring such applicants will be discussed with employees.

5. Personnel Actions: Wages, working conditions, and employee benefits shall be established and administered, and personnel actions of every type, including hiring, upgrading, promotion, transfer, demotion, layoff, and termination, shall be taken without regard to race, color, religion, sex, national origin, age or disability. The following procedures shall be followed:

a. The contractor will conduct periodic inspections of project sites to insure that working conditions and employee facilities do not indicate discriminatory treatment of project site personnel.

b. The contractor will periodically evaluate the spread of wages paid within each classification to determine any evidence of discriminatory wage practices.

c. The contractor will periodically review selected personnel actions in depth to determine whether there is evidence of discrimination. Where evidence is found, the contractor will

promptly take corrective action. If the review indicates that the discrimination may extend beyond the actions reviewed, such corrective action shall include all affected persons.

d. The contractor will promptly investigate all complaints of alleged discrimination made to the contractor in connection with its obligations under this contract, will attempt to resolve such complaints, and will take appropriate corrective action within a reasonable time. If the investigation indicates that the discrimination may affect persons other than the complainant, such corrective action shall include such other persons. Upon completion of each investigation, the contractor will inform every complainant of all of their avenues of appeal.

6. Training and Promotion:

a. The contractor will assist in locating, qualifying, and increasing the skills of minorities and women who are should be aimed at developing full journey level status employees in the type of trade or job classification involved.

b. Consistent with the contractor's work force requirements and as permissible under Federal and State regulations, the contractor shall make full use of training programs, i.e., apprenticeship, and on-the-job training programs for the geographical area of contract performance. In the event a special provision for training is provided under this contract, this subparagraph will be superseded as indicated in the special provision. The contracting agency may reserve training positions for persons who receive welfare assistance in accordance with 23 U.S.C. 140(a).

c. The contractor will advise employees and applicants for employment of available training programs and entrance requirements for each.

d. The contractor will periodically review the training and promotion potential of employees who are minorities and women and will encourage eligible employees to apply for such training and promotion.

7. Unions: If the contractor relies in whole or in part upon unions as a source of employees, the contractor will use good faith efforts to obtain the cooperation of such unions to increase opportunities for minorities and women. Actions by the contractor, either directly or through a contractor's association acting as agent, will include the procedures set forth below:

a. The contractor will use good faith efforts to develop, in cooperation with the unions, joint training programs aimed toward qualifying more minorities and women for membership in the unions and increasing the skills of minorities and women so that they may qualify for higher paying employment.

b. The contractor will use good faith efforts to incorporate an EEO clause into each union agreement to the end that such union will be contractually bound to refer applicants without regard to their race, color, religion, sex, national origin, age or disability.

c. The contractor is to obtain information as to the referral practices and policies of the labor union except that to the extent such information is within the exclusive possession of the labor union and such labor union refuses to furnish such information to the contractor, the contractor shall so certify to the contracting agency and shall set forth what efforts have been made to obtain such information.

d. In the event the union is unable to provide the contractor with a reasonable flow of referrals within the time limit set forth in the collective bargaining agreement, the contractor will, through independent recruitment efforts, fill the employment vacancies without regard to race, color, religion, sex, national origin, age or disability; making full efforts to obtain qualified and/or qualifiable minorities and women. The failure of a union to provide sufficient referrals (even though it is obligated to provide exclusive referrals under the terms of a collective bargaining agreement) does not relieve the contractor from the requirements of this paragraph. In the event the union referral practice prevents the contractor from meeting the obligations pursuant to Executive Order 11246, as amended, and these special provisions, such contractor shall immediately notify the contracting agency.

8. Reasonable Accommodation for Applicants / Employees with Disabilities: The contractor must be familiar

with the requirements for and comply with the Americans with Disabilities Act and all rules and regulations established there under. Employers must provide reasonable accommodation in all employment activities unless to do so would cause an undue hardship.

9. Selection of Subcontractors, Procurement of Materials and Leasing of Equipment: The contractor shall not discriminate on the grounds of race, color, religion, sex, national origin, age or disability in the selection and retention of subcontractors, including procurement of materials and leases of equipment. The contractor shall take all necessary and reasonable steps to ensure nondiscrimination in the administration of this contract.

a. The contractor shall notify all potential subcontractors and suppliers and lessors of their EEO obligations under this contract.

b. The contractor will use good faith efforts to ensure subcontractor compliance with their EEO obligations.

10. Assurance Required by 49 CFR 26.13(b):

a. The requirements of 49 CFR Part 26 and the State DOT's U.S. DOT-approved DBE program are incorporated by reference.

b. The contractor or subcontractor shall not discriminate on the basis of race, color, national origin, or sex in the performance of this contract. The contractor shall carry out applicable requirements of 49 CFR Part 26 in the award and administration of DOT-assisted contracts. Failure by the contractor to carry out these requirements is a material breach of this contract, which may result in the termination of this contract or such other remedy as the contracting agency deems appropriate.

11. Records and Reports: The contractor shall keep such records as necessary to document compliance with the EEO requirements. Such records shall be retained for a period of three years following the date of the final payment to the contractor for all contract work and shall be available at reasonable times and places for inspection by authorized representatives of the contracting agency and the FHWA.

a. The records kept by the contractor shall document the following:

(1) The number and work hours of minority and non-minority group members and women employed in each work classification on the project;

(2) The progress and efforts being made in cooperation with unions, when applicable, to increase employment opportunities for minorities and women; and

(3) The progress and efforts being made in locating, hiring, training, qualifying, and upgrading minorities and women;

b. The contractors and subcontractors will submit an annual report to the contracting agency each July for the duration of the project, indicating the number of minority, women, and non-minority group employees currently engaged in each work classification required by the contract work. This information is to be reported on Form FHWA-1391. The staffing data should represent the project work force on board in all or any part of the last payroll period preceding the end of July. If on-the-job training is being required by special provision, the contractor will be required to collect and report training data. The employment data should reflect the work force on board during all or any part of the last payroll period preceding the end of July.

III. NONSEGREGATED FACILITIES

This provision is applicable to all Federal-aid construction contracts and to all related construction subcontracts of \$10,000 or more.

The contractor must ensure that facilities provided for employees are provided in such a manner that segregation on the basis of race, color, religion, sex, or national origin cannot result. The contractor may neither require such segregated use by written or oral policies nor tolerate such use by employee custom. The contractor's obligation extends further to ensure that its employees are not assigned to perform their services at any location, under the contractor's control, where the facilities are segregated. The term "facilities" includes waiting rooms, work areas, restaurants and other eating areas, time clocks, restrooms, washrooms, locker rooms, and other storage or dressing areas, parking lots, drinking fountains, recreation or entertainment areas, transportation, and housing provided for employees. The contractor shall provide separate or single-user restrooms and necessary dressing or sleeping areas to assure privacy between sexes.

IV. DAVIS-BACON AND RELATED ACT PROVISIONS

This section is applicable to all Federal-aid construction projects exceeding \$2,000 and to all related subcontracts and lower-tier subcontracts (regardless of subcontract size). The requirements apply to all projects located within the right-of-way of a roadway that is functionally classified as Federal-aid highway. This

excludes roadways functionally classified as local roads or rural minor collectors, which are exempt. Contracting agencies may elect to apply these requirements to other projects.

The following provisions are from the U.S. Department of Labor regulations in 29 CFR 5.5 "Contract provisions and related matters" with minor revisions to conform to the FHWA-1273 format and FHWA program requirements.

1. Minimum wages

a. All laborers and mechanics employed or working upon the site of the work, will be paid unconditionally and not less often than once a week, and without subsequent deduction or rebate on any account (except such payroll deductions as are permitted by regulations issued by the Secretary of Labor under the Copeland Act (29 CFR part 3)), the full amount of wages and bona fide fringe benefits (or cash equivalents thereof) due at time of payment computed at rates not less than those contained in the wage determination of the Secretary of Labor which is attached hereto and made a part hereof, regardless of any contractual relationship which may be alleged to exist between the contractor and such laborers and mechanics.

Contributions made or costs reasonably anticipated for bona fide fringe benefits under section 1(b)(2) of the Davis-Bacon Act on behalf of laborers or mechanics are considered wages paid to such laborers or mechanics, subject to the provisions of paragraph 1.d. of this section; also, regular contributions made or costs incurred for more than a weekly period (but not less often than quarterly) under plans, funds, or programs which cover the particular weekly period, are deemed to be constructively made or incurred during such weekly period. Such laborers and mechanics shall be paid the appropriate wage rate and fringe benefits on the wage determination for the classification of work actually performed, without regard to skill, except as provided in 29 CFR 5.5(a)(4). Laborers or mechanics performing work in more than one classification may be compensated at the rate specified for each classification for the time actually worked therein: Provided, That the employer's payroll records accurately set forth the time spent in each classification in which work is performed. The wage determination (including any additional classification and wage rates conformed under paragraph 1.b. of this section) and the Davis-Bacon poster (WH-1321) shall be posted at all times by the contractor and its subcontractors at the site of the work in a prominent and accessible place where it can be easily seen by the workers.

b.(1) The contracting officer shall require that any class of laborers or mechanics, including helpers, which is not listed in the wage determination and which is to be employed under the contract shall be classified in conformance with the wage determination. The contracting officer shall approve an additional classification and wage rate and fringe benefits therefore only when the following criteria have been met:

(i) The work to be performed by the classification requested is not performed by a classification in the wage determination; and

(ii) The classification is utilized in the area by the construction industry; and

(iii) The proposed wage rate, including any bona fide fringe benefits, bears a reasonable relationship to the wage rates contained in the wage determination.

(2) If the contractor and the laborers and mechanics to be employed in the classification (if known), or their representatives, and the contracting officer agree on the classification and wage rate (including the amount designated for fringe benefits where appropriate), a report of the action taken shall be sent by the contracting officer to the Administrator of the Wage and Hour Division, Employment Standards Administration, U.S. Department of Labor, Washington, DC 20210. The Administrator, or an authorized representative, will approve, modify, or disapprove every additional classification action within 30 days of receipt and

so advise the contracting officer or will notify the contracting officer within the 30-day period that additional time is necessary.

(3) In the event the contractor, the laborers or mechanics to be employed in the classification or their representatives, and the contracting officer do not agree on the proposed classification and wage rate (including the amount designated for fringe benefits, where appropriate), the contracting officer shall refer the questions, including the views of all interested parties and the recommendation of the contracting officer, to the Wage and Hour Administrator for determination. The Wage and Hour Administrator, or an authorized representative, will issue a determination within 30 days of receipt and so advise the contracting officer or will notify the contracting officer within the 30-day period that additional time is necessary.

(4) The wage rate (including fringe benefits where appropriate) determined pursuant to paragraphs 1.b.(2) or 1.b.(3) of this section, shall be paid to all workers performing work in the classification under this contract from the first day on which work is performed in the classification.

c. Whenever the minimum wage rate prescribed in the contract for a class of laborers or mechanics includes a fringe benefit which is not expressed as an hourly rate, the contractor shall either pay the benefit as stated in the wage determination or shall pay another bona fide fringe benefit or an hourly cash equivalent thereof.

d. If the contractor does not make payments to a trustee or other third person, the contractor may consider as part of the wages of any laborer or mechanic the amount of any costs reasonably anticipated in providing bona fide fringe benefits under a plan or program, Provided, That the Secretary of Labor has found, upon the written request of the contractor, that the applicable standards of the Davis-Bacon Act have been met. The Secretary of Labor may require the contractor to set aside in a separate account assets for the meeting of obligations under the plan or program.

2. Withholding

The contracting agency shall upon its own action or upon written request of an authorized representative of the Department of Labor, withhold or cause to be withheld from the contractor under this contract, or any other Federal contract with the same prime contractor, or any other federally-assisted contract subject to Davis-Bacon prevailing wage requirements, which is held by the same prime contractor, so much of the accrued payments or advances as may be considered necessary to pay laborers and mechanics, including apprentices, trainees, and helpers, employed by the contractor or any subcontractor the full amount of wages required by the contract. In the event of failure to pay any laborer or mechanic, including any apprentice, trainee, or helper, employed or working on the site of the work, all or part of the wages required by the contract, the contracting agency may, after written notice to the contractor, take such action as may be necessary to cause the suspension of any further payment, advance, or guarantee of funds until such violations have ceased.

3. Payrolls and basic records

a. Payrolls and basic records relating thereto shall be maintained by the contractor during the course of the work and preserved for a period of three years thereafter for all laborers and mechanics working at the site of the work. Such records shall contain the name, address, and social security number of each such worker, his or her correct classification, hourly rates of wages paid (including rates of contributions or costs anticipated for bona fide

fringe benefits or cash equivalents thereof of the types described in section 1(b)(2)(B) of the Davis-Bacon Act), daily and weekly number of hours worked, deductions made and actual wages paid. Whenever the Secretary of Labor has found under 29 CFR 5.5(a)(1)(iv) that the wages of any laborer or mechanic include the amount of any costs reasonably anticipated in providing benefits under a plan or program described in section 1(b)(2)(B) of the Davis-Bacon Act, the contractor shall maintain records which show that the commitment to provide such benefits is enforceable, that the plan or program is financially responsible, and that the plan or program has been communicated in writing to the laborers or mechanics affected, and records which show the costs anticipated or the actual cost incurred in providing such benefits. Contractors employing apprentices or trainees under approved programs shall maintain written evidence of the registration of apprenticeship programs and certification of trainee programs, the registration of the apprentices and trainees, and the ratios and wage rates prescribed in the applicable programs.

b.(1) The contractor shall submit weekly for each week in which any contract work is performed a copy of all payrolls to the contracting agency. The payrolls submitted shall set out accurately and completely all of the information required to be maintained under 29 CFR 5.5(a)(3)(i), except that full social security numbers and home addresses shall not be included on weekly transmittals. Instead the payrolls shall only need to include an individually identifying number for each employee (e.g. , the last four digits of the employee's social security number). The required weekly payroll information may be submitted in any form desired. Optional Form WH-347 is available for this purpose from the Wage and Hour Division Web site at <http://www.dol.gov/esa/whd/forms/wh347instr.htm> or its successor site. The prime contractor is responsible for the submission of copies of payrolls by all subcontractors. Contractors and subcontractors shall maintain the full social security number and current address of each covered worker, and shall provide them upon request to the contracting agency for transmission to the State DOT, the FHWA or the Wage and Hour Division of the Department of Labor for purposes of an investigation or audit of compliance with prevailing wage requirements. It is not a violation of this section for a prime contractor to require a subcontractor to provide addresses and social security numbers to the prime contractor for its own records, without weekly submission to the contracting agency..

(2) Each payroll submitted shall be accompanied by a "Statement of Compliance," signed by the contractor or subcontractor or his or her agent who pays or supervises the payment of the persons employed under the contract and shall certify the following:

(i) That the payroll for the payroll period contains the information required to be provided under §5.5 (a)(3)(ii) of Regulations, 29 CFR part 5, the appropriate information is being maintained under §5.5 (a)(3)(i) of Regulations, 29 CFR part 5, and that such information is correct and complete;

(ii) That each laborer or mechanic (including each helper, apprentice, and trainee) employed on the contract during the payroll period has been paid the full weekly wages earned, without rebate, either directly or indirectly, and that no deductions have been made either directly or indirectly from the full wages earned, other than permissible deductions as set forth in Regulations, 29 CFR part 3:

(iii) That each laborer or mechanic has been paid not less than the applicable wage rates and fringe benefits or cash equivalents

for the classification of work performed, as specified in the applicable wage determination incorporated into the contract.

(3) The weekly submission of a properly executed certification set forth on the reverse side of Optional Form WH-347 shall satisfy the requirement for submission of the "Statement of Compliance" required by paragraph 3.b.(2) of this section.

(4) The falsification of any of the above certifications may subject the contractor or subcontractor to civil or criminal prosecution under section 1001 of title 18 and section 231 of title 31 of the United States Code.

c. The contractor or subcontractor shall make the records required under paragraph 3.a. of this section available for inspection, copying, or transcription by authorized representatives of the contracting agency, the State DOT, the FHWA, or the Department of Labor, and shall permit such representatives to interview employees during working hours on the job. If the contractor or subcontractor fails to submit the required records or to make them available, the FHWA may, after written notice to the contractor, the contracting agency or the State DOT, take such action as may be necessary to cause the suspension of any further payment, advance, or guarantee of funds. Furthermore, failure to submit the required records upon request or to make such records available may be grounds for debarment action pursuant to 29 CFR 5.12.

4. Apprentices and trainees

a. Apprentices (programs of the USDOL).

Apprentices will be permitted to work at less than the predetermined rate for the work they performed when they are employed pursuant to and individually registered in a bona fide apprenticeship program registered with the U.S. Department of Labor, Employment and Training Administration, Office of Apprenticeship Training, Employer and Labor Services, or with a State Apprenticeship Agency recognized by the Office, or if a person is employed in his or her first 90 days of probationary employment as an apprentice in such an apprenticeship program, who is not individually registered in the program, but who has been certified by the Office of Apprenticeship Training, Employer and Labor Services or a State Apprenticeship Agency (where appropriate) to be eligible for probationary employment as an apprentice.

The allowable ratio of apprentices to journeymen on the job site in any craft classification shall not be greater than the ratio permitted to the contractor as to the entire work force under the registered program. Any worker listed on a payroll at an apprentice wage rate, who is not registered or otherwise employed as stated above, shall be paid not less than the applicable wage rate on the wage determination for the classification of work actually performed. In addition, any apprentice performing work on the job site in excess of the ratio permitted under the registered program shall be paid not less than the applicable wage rate on the wage determination for the work actually performed. Where a contractor is performing construction on a project in a locality other than that in which its program is registered, the ratios and wage rates (expressed in percentages of the journeyman's hourly rate) specified in the contractor's or subcontractor's registered program shall be observed.

Every apprentice must be paid at not less than the rate specified in the registered program for the apprentice's level of progress,

expressed as a percentage of the journeymen hourly rate specified in the applicable wage determination. Apprentices shall be paid fringe benefits in accordance with the provisions of the apprenticeship program. If the apprenticeship program does not specify fringe benefits, apprentices must be paid the full amount of fringe benefits listed on the wage determination for the applicable classification. If the Administrator determines that a different practice prevails for the applicable apprentice classification, fringes shall be paid in accordance with that determination.

In the event the Office of Apprenticeship Training, Employer and Labor Services, or a State Apprenticeship Agency recognized by the Office, withdraws approval of an apprenticeship program, the contractor will no longer be permitted to utilize apprentices at less than the applicable predetermined rate for the work performed until an acceptable program is approved.

b. Trainees (programs of the USDOL).

Except as provided in 29 CFR 5.16, trainees will not be permitted to work at less than the predetermined rate for the work performed unless they are employed pursuant to and individually registered in a program which has received prior approval, evidenced by formal certification by the U.S. Department of Labor, Employment and Training Administration.

The ratio of trainees to journeymen on the job site shall not be greater than permitted under the plan approved by the Employment and Training Administration.

Every trainee must be paid at not less than the rate specified in the approved program for the trainee's level of progress, expressed as a percentage of the journeyman hourly rate specified in the applicable wage determination. Trainees shall be paid fringe benefits in accordance with the provisions of the trainee program. If the trainee program does not mention fringe benefits, trainees shall be paid the full amount of fringe benefits listed on the wage determination unless the Administrator of the Wage and Hour Division determines that there is an apprenticeship program associated with the corresponding journeyman wage rate on the wage determination which provides for less than full fringe benefits for apprentices. Any employee listed on the payroll at a trainee rate who is not registered and participating in a training plan approved by the Employment and Training Administration shall be paid not less than the applicable wage rate on the wage determination for the classification of work actually performed. In addition, any trainee performing work on the job site in excess of the ratio permitted under the registered program shall be paid not less than the applicable wage rate on the wage determination for the work actually performed.

In the event the Employment and Training Administration withdraws approval of a training program, the contractor will no longer be permitted to utilize trainees at less than the applicable predetermined rate for the work performed until an acceptable program is approved.

c. Equal employment opportunity. The utilization of apprentices, trainees and journeymen under this part shall be in conformity with the equal employment opportunity requirements of Executive Order 11246, as amended, and 29 CFR part 30.

d. Apprentices and Trainees (programs of the U.S. DOT).

Apprentices and trainees working under apprenticeship and skill training programs which have been certified by the Secretary

of Transportation as promoting EEO in connection with Federal-aid highway construction programs are not subject to the requirements of paragraph 4 of this Section IV. The straight time hourly wage rates for apprentices and trainees under such programs will be established by the particular programs. The ratio of apprentices and trainees to journeymen shall not be greater than permitted by the terms of the particular program.

5. Compliance with Copeland Act requirements. The contractor shall comply with the requirements of 29 CFR part 3, which are incorporated by reference in this contract.

6. Subcontracts. The contractor or subcontractor shall insert Form FHWA-1273 in any subcontracts and also require the subcontractors to include Form FHWA-1273 in any lower tier subcontracts. The prime contractor shall be responsible for the compliance by any subcontractor or lower tier subcontractor with all the contract clauses in 29 CFR 5.5.

7. Contract termination: debarment. A breach of the contract clauses in 29 CFR 5.5 may be grounds for termination of the contract, and for debarment as a contractor and a subcontractor as provided in 29 CFR 5.12.

8. Compliance with Davis-Bacon and Related Act requirements. All rulings and interpretations of the Davis-Bacon and Related Acts contained in 29 CFR parts 1, 3, and 5 are herein incorporated by reference in this contract.

9. Disputes concerning labor standards. Disputes arising out of the labor standards provisions of this contract shall not be subject to the general disputes clause of this contract. Such disputes shall be resolved in accordance with the procedures of the Department of Labor set forth in 29 CFR parts 5, 6, and 7. Disputes within the meaning of this clause include disputes between the contractor (or any of its subcontractors) and the contracting agency, the U.S. Department of Labor, or the employees or their representatives.

10. Certification of eligibility.

a. By entering into this contract, the contractor certifies that neither it (nor he or she) nor any person or firm who has an interest in the contractor's firm is a person or firm ineligible to be awarded Government contracts by virtue of section 3(a) of the Davis-Bacon Act or 29 CFR 5.12(a)(1).

b. No part of this contract shall be subcontracted to any person or firm ineligible for award of a Government contract by virtue of section 3(a) of the Davis-Bacon Act or 29 CFR 5.12(a)(1).

c. The penalty for making false statements is prescribed in the U.S. Criminal Code, 18 U.S.C. 1001.

V. CONTRACT WORK HOURS AND SAFETY STANDARDS ACT

The following clauses apply to any Federal-aid construction contract in an amount in excess of \$100,000 and subject to the overtime provisions of the Contract Work Hours and Safety Standards Act. These clauses shall be inserted in addition to the

clauses required by 29 CFR 5.5(a) or 29 CFR 4.6. As used in this paragraph, the terms laborers and mechanics include watchmen and guards.

1. Overtime requirements. No contractor or subcontractor contracting for any part of the contract work which may require or involve the employment of laborers or mechanics shall require or permit any such laborer or mechanic in any workweek in which he or she is employed on such work to work in excess of forty hours in such workweek unless such laborer or mechanic receives compensation at a rate not less than one and one-half times the basic rate of pay for all hours worked in excess of forty hours in such workweek.

2. Violation; liability for unpaid wages; liquidated damages. In the event of any violation of the clause set forth in paragraph (1.) of this section, the contractor and any subcontractor responsible therefor shall be liable for the unpaid wages. In addition, such contractor and subcontractor shall be liable to the United States (in the case of work done under contract for the District of Columbia or a territory, to such District or to such territory), for liquidated damages. Such liquidated damages shall be computed with respect to each individual laborer or mechanic, including watchmen and guards, employed in violation of the clause set forth in paragraph (1.) of this section, in the sum of \$10 for each calendar day on which such individual was required or permitted to work in excess of the standard workweek of forty hours without payment of the overtime wages required by the clause set forth in paragraph (1.) of this section.

3. Withholding for unpaid wages and liquidated damages. The FHWA or the contacting agency shall upon its own action or upon written request of an authorized representative of the Department of Labor withhold or cause to be withheld, from any moneys payable on account of work performed by the contractor or subcontractor under any such contract or any other Federal contract with the same prime contractor, or any other federally-assisted contract subject to the Contract Work Hours and Safety Standards Act, which is held by the same prime contractor, such sums as may be determined to be necessary to satisfy any liabilities of such contractor or subcontractor for unpaid wages and liquidated damages as provided in the clause set forth in paragraph (2.) of this section.

4. Subcontracts. The contractor or subcontractor shall insert in any subcontracts the clauses set forth in paragraph (1.) through (4.) of this section and also a clause requiring the subcontractors to include these clauses in any lower tier subcontracts. The prime contractor shall be responsible for compliance by any subcontractor or lower tier subcontractor with the clauses set forth in paragraphs (1.) through (4.) of this section.

VI. SUBLETTING OR ASSIGNING THE CONTRACT

This provision is applicable to all Federal-aid construction contracts on the National Highway System.

1. The contractor shall perform with its own organization contract work amounting to not less than 30 percent (or a greater percentage if specified elsewhere in the contract) of the total original contract price, excluding any specialty items designated by the contracting agency. Specialty items may be performed by subcontract and the amount of any such specialty items performed

may be deducted from the total original contract price before computing the amount of work required to be performed by the contractor's own organization (23 CFR 635.116).

a. The term "perform work with its own organization" refers to workers employed or leased by the prime contractor, and equipment owned or rented by the prime contractor, with or without operators. Such term does not include employees or equipment of a subcontractor or lower tier subcontractor, agents of the prime contractor, or any other assignees. The term may include payments for the costs of hiring leased employees from an employee leasing firm meeting all relevant Federal and State regulatory requirements. Leased employees may only be included in this term if the prime contractor meets all of the following conditions:

- (1) the prime contractor maintains control over the supervision of the day-to-day activities of the leased employees;
- (2) the prime contractor remains responsible for the quality of the work of the leased employees;
- (3) the prime contractor retains all power to accept or exclude individual employees from work on the project; and
- (4) the prime contractor remains ultimately responsible for the payment of predetermined minimum wages, the submission of payrolls, statements of compliance and all other Federal regulatory requirements.

b. "Specialty Items" shall be construed to be limited to work that requires highly specialized knowledge, abilities, or equipment not ordinarily available in the type of contracting organizations qualified and expected to bid or propose on the contract as a whole and in general are to be limited to minor components of the overall contract.

2. The contract amount upon which the requirements set forth in paragraph (1) of Section VI is computed includes the cost of material and manufactured products which are to be purchased or produced by the contractor under the contract provisions.

3. The contractor shall furnish (a) a competent superintendent or supervisor who is employed by the firm, has full authority to direct performance of the work in accordance with the contract requirements, and is in charge of all construction operations (regardless of who performs the work) and (b) such other of its own organizational resources (supervision, management, and engineering services) as the contracting officer determines is necessary to assure the performance of the contract.

4. No portion of the contract shall be sublet, assigned or otherwise disposed of except with the written consent of the contracting officer, or authorized representative, and such consent when given shall not be construed to relieve the contractor of any responsibility for the fulfillment of the contract. Written consent will be given only after the contracting agency has assured that each subcontract is evidenced in writing and that it contains all pertinent provisions and requirements of the prime contract.

5. The 30% self-performance requirement of paragraph (1) is not applicable to design-build contracts; however, contracting agencies may establish their own self-performance requirements.

VII. SAFETY: ACCIDENT PREVENTION

This provision is applicable to all Federal-aid construction contracts and to all related subcontracts.

1. In the performance of this contract the contractor shall comply with all applicable Federal, State, and local laws governing safety, health, and sanitation (23 CFR 635). The contractor shall provide all safeguards, safety devices and protective equipment and take any other needed actions as it determines, or as the contracting officer may determine, to be reasonably necessary to protect the life and health of employees on the job and the safety of the public and to protect property in connection with the performance of the work covered by the contract.

2. It is a condition of this contract, and shall be made a condition of each subcontract, which the contractor enters into pursuant to this contract, that the contractor and any subcontractor shall not permit any employee, in performance of the contract, to work in surroundings or under conditions which are unsanitary, hazardous or dangerous to his/her health or safety, as determined under construction safety and health standards (29 CFR 1926) promulgated by the Secretary of Labor, in accordance with Section 107 of the Contract Work Hours and Safety Standards Act (40 U.S.C. 3704).

3. Pursuant to 29 CFR 1926.3, it is a condition of this contract that the Secretary of Labor or authorized representative thereof, shall have right of entry to any site of contract performance to inspect or investigate the matter of compliance with the construction safety and health standards and to carry out the duties of the Secretary under Section 107 of the Contract Work Hours and Safety Standards Act (40 U.S.C.3704).

VIII. FALSE STATEMENTS CONCERNING HIGHWAY PROJECTS

This provision is applicable to all Federal-aid construction contracts and to all related subcontracts.

In order to assure high quality and durable construction in conformity with approved plans and specifications and a high degree of reliability on statements and representations made by engineers, contractors, suppliers, and workers on Federal-aid highway projects, it is essential that all persons concerned with the project perform their functions as carefully, thoroughly, and honestly as possible. Willful falsification, distortion, or misrepresentation with respect to any facts related to the project is a violation of Federal law. To prevent any misunderstanding regarding the seriousness of these and similar acts, Form FHWA-1022 shall be posted on each Federal-aid highway project (23 CFR 635) in one or more places where it is readily available to all persons concerned with the project:

18 U.S.C. 1020 reads as follows:

"Whoever, being an officer, agent, or employee of the United States, or of any State or Territory, or whoever, whether a person, association, firm, or corporation, knowingly makes any false statement, false representation, or false report as to the character, quality, quantity, or cost of the material used or to be used, or the quantity or quality of the work performed or to be performed, or the cost thereof in connection with the submission of plans, maps, specifications, contracts, or costs of construction on any highway or related project submitted for approval to the Secretary of Transportation; or

Whoever knowingly makes any false statement, false representation, false report or false claim with respect to the

character, quality, quantity, or cost of any work performed or to be performed, or materials furnished or to be furnished, in connection with the construction of any highway or related project approved by the Secretary of Transportation; or

Whoever knowingly makes any false statement or false representation as to material fact in any statement, certificate, or report submitted pursuant to provisions of the Federal-aid Roads Act approved July 1, 1916, (39 Stat. 355), as amended and supplemented;

Shall be fined under this title or imprisoned not more than 5 years or both."

IX. IMPLEMENTATION OF CLEAN AIR ACT AND FEDERAL WATER POLLUTION CONTROL ACT

This provision is applicable to all Federal-aid construction contracts and to all related subcontracts.

By submission of this bid/proposal or the execution of this contract, or subcontract, as appropriate, the bidder, proposer, Federal-aid construction contractor, or subcontractor, as appropriate, will be deemed to have stipulated as follows:

1. That any person who is or will be utilized in the performance of this contract is not prohibited from receiving an award due to a violation of Section 508 of the Clean Water Act or Section 306 of the Clean Air Act.

2. That the contractor agrees to include or cause to be included the requirements of paragraph (1) of this Section X in every subcontract, and further agrees to take such action as the contracting agency may direct as a means of enforcing such requirements.

X. CERTIFICATION REGARDING DEBARMENT, SUSPENSION, INELIGIBILITY AND VOLUNTARY EXCLUSION

This provision is applicable to all Federal-aid construction contracts, design-build contracts, subcontracts, lower-tier subcontracts, purchase orders, lease agreements, consultant contracts or any other covered transaction requiring FHWA approval or that is estimated to cost \$25,000 or more – as defined in 2 CFR Parts 180 and 1200.

1. Instructions for Certification – First Tier Participants:

a. By signing and submitting this proposal, the prospective first tier participant is providing the certification set out below.

b. The inability of a person to provide the certification set out below will not necessarily result in denial of participation in this covered transaction. The prospective first tier participant shall submit an explanation of why it cannot provide the certification set out below. The certification or explanation will be considered in connection with the department or agency's determination whether to enter into this transaction. However, failure of the prospective first tier participant to furnish a certification or an explanation shall disqualify such a person from participation in this transaction.

c. The certification in this clause is a material representation of fact upon which reliance was placed when the contracting agency determined to enter into this transaction. If it is later determined that the prospective participant knowingly rendered an erroneous certification, in addition to other remedies available to the Federal Government, the contracting agency may terminate this transaction for cause of default.

d. The prospective first tier participant shall provide immediate written notice to the contracting agency to whom this proposal is submitted if any time the prospective first tier participant learns that its certification was erroneous when submitted or has become erroneous by reason of changed circumstances.

e. The terms "covered transaction," "debarred," "suspended," "ineligible," "participant," "person," "principal," and "voluntarily excluded," as used in this clause, are defined in 2 CFR Parts 180 and 1200. "First Tier Covered Transactions" refers to any covered transaction between a grantee or subgrantee of Federal funds and a participant (such as the prime or general contract). "Lower Tier Covered Transactions" refers to any covered transaction under a First Tier Covered Transaction (such as subcontracts). "First Tier Participant" refers to the participant who has entered into a covered transaction with a grantee or subgrantee of Federal funds (such as the prime or general contractor). "Lower Tier Participant" refers any participant who has entered into a covered transaction with a First Tier Participant or other Lower Tier Participants (such as subcontractors and suppliers).

f. The prospective first tier participant agrees by submitting this proposal that, should the proposed covered transaction be entered into, it shall not knowingly enter into any lower tier covered transaction with a person who is debarred, suspended, declared ineligible, or voluntarily excluded from participation in this covered transaction, unless authorized by the department or agency entering into this transaction.

g. The prospective first tier participant further agrees by submitting this proposal that it will include the clause titled "Certification Regarding Debarment, Suspension, Ineligibility and Voluntary Exclusion-Lower Tier Covered Transactions," provided by the department or contracting agency, entering into this covered transaction, without modification, in all lower tier covered transactions and in all solicitations for lower tier covered transactions exceeding the \$25,000 threshold.

h. A participant in a covered transaction may rely upon a certification of a prospective participant in a lower tier covered transaction that is not debarred, suspended, ineligible, or voluntarily excluded from the covered transaction, unless it knows that the certification is erroneous. A participant is responsible for ensuring that its principals are not suspended, debarred, or otherwise ineligible to participate in covered transactions. To verify the eligibility of its principals, as well as the eligibility of any lower tier prospective participants, each participant may, but is not required to, check the Excluded Parties List System website (<https://www.epls.gov/>), which is compiled by the General Services Administration.

i. Nothing contained in the foregoing shall be construed to require the establishment of a system of records in order to render in good faith the certification required by this clause. The knowledge and information of the prospective participant is not required to exceed that which is normally possessed by a prudent person in the ordinary course of business dealings.

j. Except for transactions authorized under paragraph (f) of these instructions, if a participant in a covered transaction knowingly enters into a lower tier covered transaction with a person who is suspended, debarred, ineligible, or voluntarily excluded from participation in this transaction, in addition to other remedies available to the Federal Government, the department or agency may terminate this transaction for cause or default.

* * * * *

2. Certification Regarding Debarment, Suspension, Ineligibility and Voluntary Exclusion – First Tier Participants:

a. The prospective first tier participant certifies to the best of its knowledge and belief, that it and its principals:

(1) Are not presently debarred, suspended, proposed for debarment, declared ineligible, or voluntarily excluded from participating in covered transactions by any Federal department or agency;

(2) Have not within a three-year period preceding this proposal been convicted of or had a civil judgment rendered against them for commission of fraud or a criminal offense in connection with obtaining, attempting to obtain, or performing a public (Federal, State or local) transaction or contract under a public transaction; violation of Federal or State antitrust statutes or commission of embezzlement, theft, forgery, bribery, falsification or destruction of records, making false statements, or receiving stolen property;

(3) Are not presently indicted for or otherwise criminally or civilly charged by a governmental entity (Federal, State or local) with commission of any of the offenses enumerated in paragraph (a)(2) of this certification; and

(4) Have not within a three-year period preceding this application/proposal had one or more public transactions (Federal, State or local) terminated for cause or default.

b. Where the prospective participant is unable to certify to any of the statements in this certification, such prospective participant shall attach an explanation to this proposal.

2. Instructions for Certification - Lower Tier Participants:

(Applicable to all subcontracts, purchase orders and other lower tier transactions requiring prior FHWA approval or estimated to cost \$25,000 or more - 2 CFR Parts 180 and 1200)

a. By signing and submitting this proposal, the prospective lower tier is providing the certification set out below.

b. The certification in this clause is a material representation of fact upon which reliance was placed when this transaction was entered into. If it is later determined that the prospective lower tier participant knowingly rendered an erroneous certification, in addition to other remedies available to the Federal Government, the department, or agency with which this transaction originated may pursue available remedies, including suspension and/or debarment.

c. The prospective lower tier participant shall provide immediate written notice to the person to which this proposal is

submitted if at any time the prospective lower tier participant learns that its certification was erroneous by reason of changed circumstances.

d. The terms "covered transaction," "debarred," "suspended," "ineligible," "participant," "person," "principal," and "voluntarily excluded," as used in this clause, are defined in 2 CFR Parts 180 and 1200. You may contact the person to which this proposal is submitted for assistance in obtaining a copy of those regulations. "First Tier Covered Transactions" refers to any covered transaction between a grantee or subgrantee of Federal funds and a participant (such as the prime or general contract). "Lower Tier Covered Transactions" refers to any covered transaction under a First Tier Covered Transaction (such as subcontracts). "First Tier Participant" refers to the participant who has entered into a covered transaction with a grantee or subgrantee of Federal funds (such as the prime or general contractor). "Lower Tier Participant" refers any participant who has entered into a covered transaction with a First Tier Participant or other Lower Tier Participants (such as subcontractors and suppliers).

e. The prospective lower tier participant agrees by submitting this proposal that, should the proposed covered transaction be entered into, it shall not knowingly enter into any lower tier covered transaction with a person who is debarred, suspended, declared ineligible, or voluntarily excluded from participation in this covered transaction, unless authorized by the department or agency with which this transaction originated.

f. The prospective lower tier participant further agrees by submitting this proposal that it will include this clause titled "Certification Regarding Debarment, Suspension, Ineligibility and Voluntary Exclusion-Lower Tier Covered Transaction," without modification, in all lower tier covered transactions and in all solicitations for lower tier covered transactions exceeding the \$25,000 threshold.

g. A participant in a covered transaction may rely upon a certification of a prospective participant in a lower tier covered transaction that is not debarred, suspended, ineligible, or voluntarily excluded from the covered transaction, unless it knows that the certification is erroneous. A participant is responsible for ensuring that its principals are not suspended, debarred, or otherwise ineligible to participate in covered transactions. To verify the eligibility of its principals, as well as the eligibility of any lower tier prospective participants, each participant may, but is not required to, check the Excluded Parties List System website (<https://www.epls.gov/>), which is compiled by the General Services Administration.

h. Nothing contained in the foregoing shall be construed to require establishment of a system of records in order to render in good faith the certification required by this clause. The knowledge and information of participant is not required to exceed that which is normally possessed by a prudent person in the ordinary course of business dealings.

i. Except for transactions authorized under paragraph e of these instructions, if a participant in a covered transaction knowingly enters into a lower tier covered transaction with a person who is suspended, debarred, ineligible, or voluntarily excluded from participation in this transaction, in addition to other remedies available to the Federal Government, the 11

department or agency with which this transaction originated may pursue available remedies, including suspension and/or debarment.

* * * * *

Certification Regarding Debarment, Suspension, Ineligibility and Voluntary Exclusion—Lower Tier Participants:

1. The prospective lower tier participant certifies, by submission of this proposal, that neither it nor its principals is presently debarred, suspended, proposed for debarment, declared ineligible, or voluntarily excluded from participating in covered transactions by any Federal department or agency.

2. Where the prospective lower tier participant is unable to certify to any of the statements in this certification, such prospective participant shall attach an explanation to this proposal.

* * * * *

XI. CERTIFICATION REGARDING USE OF CONTRACT FUNDS FOR LOBBYING

This provision is applicable to all Federal-aid construction contracts and to all related subcontracts which exceed \$100,000 (49 CFR 20).

1. The prospective participant certifies, by signing and submitting this bid or proposal, to the best of his or her knowledge and belief, that:

a. No Federal appropriated funds have been paid or will be paid, by or on behalf of the undersigned, to any person for influencing or attempting to influence an officer or employee of any Federal agency, a Member of Congress, an officer or employee of Congress, or an employee of a Member of Congress in connection with the awarding of any Federal contract, the making of any Federal grant, the making of any Federal loan, the entering into of any cooperative agreement, and the extension, continuation, renewal, amendment, or modification of any Federal contract, grant, loan, or cooperative agreement.

b. If any funds other than Federal appropriated funds have been paid or will be paid to any person for influencing or attempting to influence an officer or employee of any Federal agency, a Member of Congress, an officer or employee of Congress, or an employee of a Member of Congress in connection with this Federal contract, grant, loan, or cooperative agreement, the undersigned shall complete and submit Standard Form-LLL, "Disclosure Form to Report Lobbying," in accordance with its instructions.

2. This certification is a material representation of fact upon which reliance was placed when this transaction was made or entered into. Submission of this certification is a prerequisite for making or entering into this transaction imposed by 31 U.S.C. 1352. Any person who fails to file the required certification shall be subject to a civil penalty of not less than \$10,000 and not more than \$100,000 for each such failure.

3. The prospective participant also agrees by submitting its bid or proposal that the participant shall require that the language of this certification be included in all lower tier subcontracts, which exceed \$100,000 and that all such recipients shall certify and disclose accordingly.

ATTACHMENT A - EMPLOYMENT AND MATERIALS PREFERENCE FOR APPALACHIAN DEVELOPMENT HIGHWAY SYSTEM OR APPALACHIAN LOCAL ACCESS ROAD CONTRACTS

This provision is applicable to all Federal-aid projects funded under the Appalachian Regional Development Act of 1965.

1. During the performance of this contract, the contractor undertaking to do work which is, or reasonably may be, done as on-site work, shall give preference to qualified persons who regularly reside in the labor area as designated by the DOL wherein the contract work is situated, or the subregion, or the Appalachian counties of the State wherein the contract work is situated, except:

a. To the extent that qualified persons regularly residing in the area are not available.

b. For the reasonable needs of the contractor to employ supervisory or specially experienced personnel necessary to assure an efficient execution of the contract work.

c. For the obligation of the contractor to offer employment to present or former employees as the result of a lawful collective bargaining contract, provided that the number of nonresident persons employed under this subparagraph (1c) shall not exceed 20 percent of the total number of employees employed by the contractor on the contract work, except as provided in subparagraph (4) below.

2. The contractor shall place a job order with the State Employment Service indicating (a) the classifications of the laborers, mechanics and other employees required to perform the contract work, (b) the number of employees required in each classification, (c) the date on which the participant estimates such employees will be required, and (d) any other pertinent information required by the State Employment Service to complete the job order form. The job order may be placed with the State Employment Service in writing or by telephone. If during the course of the contract work, the information submitted by the contractor in the original job order is substantially modified, the participant shall promptly notify the State Employment Service.

3. The contractor shall give full consideration to all qualified job applicants referred to him by the State Employment Service. The contractor is not required to grant employment to any job applicants who, in his opinion, are not qualified to perform the classification of work required.

4. If, within one week following the placing of a job order by the contractor with the State Employment Service, the State Employment Service is unable to refer any qualified job applicants to the contractor, or less than the number requested, the State Employment Service will forward a certificate to the contractor indicating the unavailability of applicants. Such certificate shall be made a part of the contractor's permanent project records. Upon receipt of this certificate, the contractor may employ persons who do not normally reside in the labor area to fill positions covered by the certificate, notwithstanding the provisions of subparagraph (1c) above.

5. The provisions of 23 CFR 633.207(e) allow the contracting agency to provide a contractual preference for the use of mineral resource materials native to the Appalachian region.

6. The contractor shall include the provisions of Sections 1 through 4 of this Attachment A in every subcontract for work which is, or reasonably may be, done as on-site work.

Female and Minority Goals

To comply with Section II, "Nondiscrimination," of "Required Contract Provisions Federal-Aid Construction Contracts," the following female and minority utilization goals for Federal-aid construction contracts and subcontracts that exceed \$10,000.

The nationwide goal for female utilization is 6.9 percent.

The goals for minority utilization [45 Fed Reg 65984 (10/3/1980)] are as follows:

Minority Utilization Goals

	Economic Area	Goal (Percent)
174	Redding CA: Non-SMSA Counties: CA Lassen; CA Modoc; CA Plumas; CA Shasta; CA Siskiyou; CA Tehama	6.8
175	Eureka, CA Non-SMSA Counties: CA Del Norte; CA Humboldt; CA Trinity	6.6
176	San Francisco-Oakland-San Jose, CA: SMSA Counties: 7120 Salinas-Seaside-Monterey, CA CA Monterey 7360 San Francisco-Oakland CA Alameda; CA Contra Costa; CA Marin; CA San Francisco; CA San Mateo 7400 San Jose, CA CA Santa Clara, CA 7485 Santa Cruz, CA CA Santa Cruz 7500 Santa Rosa CA Sonoma 8720 Vallejo-Fairfield-Napa, CA CA Napa; CA Solano Non-SMSA Counties: CA Lake; CA Mendocino; CA San Benito	28.9 25.6 19.6 14.9 9.1 17.1 23.2
177	Sacramento, CA: SMSA Counties: 6920 Sacramento, CA CA Placer; CA Sacramento; CA Yolo Non-SMSA Counties CA Butte; CA Colusa; CA El Dorado; CA Glenn; CA Nevada; CA Sierra; CA Sutter; CA Yuba	16.1 14.3
178	Stockton-Modesto, CA: SMSA Counties: 5170 Modesto, CA CA Stanislaus 8120 Stockton, CA CA San Joaquin Non-SMSA Counties CA Alpine; CA Amador; CA Calaveras; CA Mariposa; CA Merced; CA Tuolumne	12.3 24.3 19.8
179	Fresno-Bakersfield, CA SMSA Counties: 0680 Bakersfield, CA CA Kern 2840 Fresno, CA CA Fresno Non-SMSA Counties:	19.1 26.1 23.6
14	CA Kings; CA Madera; CA Tulare	

180	Los Angeles, CA:	
	SMSA Counties:	
	0360 Anaheim-Santa Ana-Garden Grove, CA	11.9
	CA Orange	
	4480 Los Angeles-Long Beach, CA	28.3
	CA Los Angeles	
	6000 Oxnard-Simi Valley-Ventura, CA	21.5
	CA Ventura	
	6780 Riverside-San Bernardino-Ontario, CA	19.0
	CA Riverside; CA San Bernardino	
7480 Santa Barbara-Santa Maria-Lompoc, CA	19.7	
CA Santa Barbara		
Non-SMSA Counties	24.6	
CA Inyo; CA Mono; CA San Luis Obispo		
181	San Diego, CA:	
	SMSA Counties	
	7320 San Diego, CA	16.9
	CA San Diego	
Non-SMSA Counties	18.2	
CA Imperial		

For each July during which work is performed under the contract, you and each non-material-supplier subcontractor with a subcontract of \$10,000 or more must complete Form FHWA PR-1391 (Appendix C to 23 CFR 230). Submit the forms by August 15.

Training

This section applies if a number of trainees or apprentices is specified in the special provisions.

As part of your equal opportunity affirmative action program, provide on-the-job training to develop full journeymen in the types of trades or job classifications involved.

You have primary responsibility for meeting this training requirement.

If you subcontract a contract part, determine how many trainees or apprentices are to be trained by the subcontractor.

Include these training requirements in your subcontract.

Where feasible, 25 percent of apprentices or trainees in each occupation must be in their 1st year of apprenticeship or training.

Distribute the number of apprentices or trainees among the work classifications on the basis of your needs and the availability of journeymen in the various classifications within a reasonable recruitment area.

Before starting work, submit to the County of Humboldt

1. Number of apprentices or trainees to be trained for each classification
2. Training program to be used
3. Training starting date for each classification

Obtain the County of Humboldt's approval for this submitted information before you start work. The County of Humboldt credits you for each apprentice or trainee you employ on the work who is currently enrolled or becomes enrolled in an approved program.

The primary objective of this section is to train and upgrade minorities and women toward journeymen status. Make every effort to enroll minority and women apprentices or trainees, such as conducting systematic and direct recruitment through public and private sources likely to yield minority and women apprentices or trainees, to the extent they are available within a reasonable recruitment area. Show that you have made the efforts. In making these efforts, do not discriminate against any applicant for training.

Do not employ as an apprentice or trainee an employee:

1. In any classification in which the employee has successfully completed a training course leading to journeyman status or in which the employee has been employed as a journeyman
2. Who is not registered in a program approved by the US Department of Labor, Bureau of Apprenticeship and Training

Ask the employee if the employee has successfully completed a training course leading to journeyman status or has been employed as a journeyman. Your records must show the employee's answers to the questions.

In your training program, establish the minimum length and training type for each classification. The County of Humboldt and FHWA approves a program if one of the following is met:

1. It is calculated to:

- 1.1. Meet the your equal employment opportunity responsibilities
- 1.2. Qualify the average apprentice or trainee for journeyman status in the classification involved by the end of the training period

2. It is registered with the U.S. Department of Labor, Bureau of Apprenticeship and Training and it is administered in a way consistent with the equal employment responsibilities of federal-aid highway construction contracts

Obtain the State's approval for your training program before you start work involving the classification covered by the program.

Provide training in the construction crafts, not in clerk-typist or secretarial-type positions. Training is allowed in lower level management positions such as office engineers, estimators, and timekeepers if the training is oriented toward construction applications. Training is allowed in the laborer classification if significant and meaningful training is provided and approved by the division office. Off-site training is allowed if the training is an integral part of an approved training program and does not make up a significant part of the overall training.

The County of Humboldt reimburses you 80 cents per hour of training given an employee on this contract under an approved training program:

1. For on-site training
2. For off-site training if the apprentice or trainee is currently employed on a federal-aid project and you do at least one of the following:
 - 2.1. Contribute to the cost of the training
 - 2.2. Provide the instruction to the apprentice or trainee
 - 2.3. Pay the apprentice's or trainee's wages during the off-site training period

3. If you comply with this section.

Each apprentice or trainee must:

1. Begin training on the project as soon as feasible after the start of work involving the apprentice's or trainee's skill
2. Remain on the project as long as training opportunities exist in the apprentice's or trainee's work classification or until the apprentice or trainee has completed the training program

Furnish the apprentice or trainee:

1. Copy of the program you will comply with in providing the training
2. Certification showing the type and length of training satisfactorily completed

Title VI Assurances

During the performance of this Agreement, the contractor, for itself, its assignees and successors in interest (hereinafter collectively referred to as CONTRACTOR) agrees as follows:

- (7) Compliance with Regulations: CONTRACTOR shall comply with the regulations relative to nondiscrimination in federally assisted programs of the Department of Transportation, Title 49, Code of Federal Regulations, Part 21, as they may be amended from time to time, (hereinafter referred to as the REGULATIONS), which are herein incorporated by reference and made a part of this agreement.
- (8) Nondiscrimination: CONTRACTOR, with regard to the work performed by it during the AGREEMENT, shall not discriminate on the grounds of race, color, sex, national origin, religion, age, or disability in the selection and retention of sub-applicants, including procurements of materials and leases of equipment. CONTRACTOR shall not participate either directly or indirectly in the discrimination prohibited by Section 21.5 of the Regulations, including employment practices when the agreement covers a program set forth in Appendix B of the Regulations.
- (9) Solicitations for Sub-agreements, Including Procurements of Materials and Equipment: In all solicitations either by competitive bidding or negotiation made by CONTRACTOR for work to be performed under a Sub-agreement, including procurements of materials or leases of equipment, each potential sub-applicant or supplier shall be notified by CONTRACTOR of the CONTRACTOR'S obligations under this Agreement and the Regulations relative to nondiscrimination on the grounds of race, color, or national origin.
- (10) Information and Reports: CONTRACTOR shall provide all information and reports required by the Regulations, or directives issued pursuant thereto, and shall permit access to its books, records, accounts, other sources of information, and its facilities as may be determined by the California Department of Transportation or FHWA to be pertinent to ascertain compliance with such Regulations or directives. Where any information required of CONTRACTOR is in the exclusive possession of another who fails or refuses to furnish this information, CONTRACTOR shall so certify to the California Department of Transportation or the FHWA as appropriate, and shall set forth what efforts CONTRACTOR has made to obtain the information.
- (11) Sanctions for Noncompliance: In the event of CONTRACTOR's noncompliance with the nondiscrimination provisions of this agreement, the California Department of Transportation shall impose such agreement sanctions as it or the FHWA may determine to be appropriate, including, but not limited to:
 - (c) withholding of payments to CONTRACTOR under the Agreement within a reasonable period of time, not to exceed 90 days; and/or
 - (d) cancellation, termination or suspension of the Agreement, in whole or in part.
- (12) Incorporation of Provisions: CONTRACTOR shall include the provisions of paragraphs (1) through (6) in every sub-agreement, including procurements of materials and leases of equipment, unless exempt by the Regulations, or directives issued pursuant thereto.

CONTRACTOR shall take such action with respect to any sub-agreement or procurement as the California Department of Transportation or FHWA may direct as a means of enforcing such provisions including sanctions for noncompliance, provided, however, that, in the event CONTRACTOR becomes involved in, or is threatened with, litigation with a sub-applicant or supplier as a result of such direction, CONTRACTOR may request the California Department of Transportation enter into such litigation to protect the interests of the State, and, in addition, CONTRACTOR may request the United States to enter into such litigation to protect the interests of the United States.

Maintain records and submit reports documenting your performance under this section.

^^

Add to section 9-1.16C:

The following items are eligible for progress payment even if they are not incorporated into the work:

1. Bar Reinforcing Steel
2. 6" Welded Steel Pipe Conduit
3. Furnish Steel Piling (HP 10x42)
4. Furnish Steel Piling (HP 14x89)
5. Prestressing Cast-In-Place Concrete
6. Joint Seal (MR 1")
7. Headed Bar Reinforcement
8. Rock Slope Protection Fabric (Class 8)
9. Miscellaneous Metal
10. California ST-30 Bridge Railing

Replace section 9-1.16F:

No retainage will be held by the agency from progress payments due to the prime contractor. Prime contractors and subcontractors are prohibited from holding retainage from subcontractors. Any delay or postponement of payment may take place only for good cause and with the agency's prior written approval. Any violation of these provisions shall subject the violating contractor or subcontractor to the penalties, sanctions, and other remedies specified in Section 7108.5 of the California Business and Professions Code. This requirement shall not be construed to limit or impair any contractual, administrative, or judicial remedies, otherwise available to the contractor or subcontractor in the event of a dispute involving late payment or nonpayment by the contractor, deficient subcontractor performance, and/or noncompliance by a subcontractor. This clause applies to both DBE and non-DBE subcontractors.

Replace section 9-1.17B:

After Contract acceptance by the Board of Supervisors of the County of Humboldt, the Department pays you based on the Engineer-prepared estimate that includes withholds and the balance due after deduction of previous payments.

Replace sections 9-1.17(D) through 9-1.22, with the following:

9-1.17D Final Payment and Claims

9-1.17D(1) Effective January 1, 2017, Sections 9-1.17D through 9-1.22 of the Standard Specifications shall be replaced with the following provisions as required by California Public Contract Code Section 9204 (California Assembly Bill 626).

9-1.17D(2) For purposes of this section:

1. "Claim" means a separate demand by a contractor sent by registered mail or certified mail with return receipt requested, for one or more of the following:
 - 1.1 A time extension, including, without limitation, for relief from damages or penalties for delay assessed by a public entity under a contract for a public works project.

- 1.2 Payment by the public entity of money or damages arising from work done by, or on behalf of, the contractor pursuant to the contract for a public works project and payment for which is not otherwise expressly provided or to which the claimant is not otherwise entitled.
- 1.3 Payment of an amount that is disputed by the public entity.
2. "Contractor" means any type of contractor within the meaning of Chapter 9 (commencing with Section 7000) of Division 3 of the California Business and Professions Code who has entered into a direct contract with a public entity for a public works project.
3. "Public entity" means, without limitation, except as provided herein, a state agency, department, office, division, bureau, board, or commission, the California State University, the University of California, a city, including a charter city, county, including a charter county, city and county, including a charter city and county, district, special district, public authority, political subdivision, public corporation, or nonprofit transit corporation wholly owned by a public agency and formed to carry out the purposes of the public agency. However, the term "public entity" shall not include any of the following:
 - 3.1 The Department of Water Resources as to any project under the jurisdiction of that department.
 - 3.2 The Department of Transportation as to any project under the jurisdiction of that department.
 - 3.3 The Department of Parks and Recreation as to any project under the jurisdiction of that department.
 - 3.4 The Department of Correction and Rehabilitation with respect to any project under its jurisdiction pursuant to Chapter 11 (commencing with section 7000) of Title 7 of Part 3 of the California Penal Code.
 - 3.5 The Military Department as to any project under the jurisdiction of that department.
 - 3.6 The Department of General Services as to all other projects.
 - 3.7 The High-Speed Rail Authority.
4. "Public works project" means the erection, construction, alteration, repair, or improvement of any public structure, building, road, or other public improvement of any kind.
5. "subcontractor" means any type of contractor within the meaning of Chapter 9 (commencing with Section 7000) of Division 3 of the California Business and Professions Code who either is in direct contract with a contractor or is a lower tier subcontractor.

9-1.17D(3)(a) Upon receipt of a claim pursuant to this section, the public entity to which the claim applies shall conduct a reasonable review of the claim and, within a period not to exceed 45 days, shall provide the claimant a written statement identifying what portion of the claim is disputed and what portion is undisputed. Upon receipt of a claim, a public entity and a contractor may, by mutual agreement, extend the time period provided in this subdivision.

9-1.17D(3)(b) The claimant shall furnish reasonable documentation to support the claim.

9-1.17D(3)(c) If the public entity needs approval from its governing body to provide the claimant a written statement identifying the disputed portion and the undisputed portion of the claim, and the governing body does not meet within the 45 days or within the mutually agreed to extension of time following receipt of a claim sent

by registered mail or certified mail, return receipt requested, the public entity shall have up to three days following the next duly publicly noticed meeting of the governing body after the 45-day period, or extension, expires to provide the claimant a written statement identifying the disputed portion and the undisputed portion.

9-1.17D(3)(d) Any payment due on an undisputed portion of the claim shall be processed and made within 60 days after the public entity issues its written statement. If the public entity fails to issue a written statement, paragraph (3) shall apply.

9-1.17D(4)(a) If the claimant disputes the public entity's written response, or if the public entity fails to respond to a claim issued pursuant to this section within the time prescribed, the claimant may demand in writing an informal conference to meet and confer for settlement of the issues in dispute. Upon receipt of a demand in writing sent by registered mail or certified mail, return receipt requested, the public entity shall schedule a meet and confer conference within 30 days for settlement of the dispute.

9-1.17D(4)(b) Within 10 business days following the conclusion of the meet and confer conference, if the claim or any portion of the claim remains in dispute, the public entity shall provide the claimant a written statement identifying the portion of the claim that remains in dispute and the portion that is undisputed. Any payment due on an undisputed portion of the claim shall be processed and made within 60 days after the public entity issues its written statement. Any disputed portion of the claim, as identified by the contractor in writing, shall be submitted to nonbinding mediation, with the public entity and the claimant sharing the associated costs equally. The public entity and claimant shall mutually agree to a mediator within 10 business days after the disputed portion of the claim has been identified in writing. If the parties cannot agree upon a mediator, each party shall select a mediator and those mediators shall select a qualified neutral third party to mediate with regard to the disputed portion of the claim. Each party shall bear the fees and costs charged by its respective mediator in connection with the selection of the neutral mediator. If mediation is unsuccessful, the parts of the claim remaining in dispute shall be subject to applicable procedures outside this section.

9-1.17D(4)(c) For purposes of this section, mediation includes any nonbinding process, including, but not limited to, neutral evaluation or a dispute review board, in which an independent third party or board assists the parties in dispute resolution through negotiation or by issuance of an evaluation. Any mediation utilized shall conform to the timeframes in this section.

9-1.17D(4)(d) Unless otherwise agreed to by the public entity and the contractor in writing, the mediation conducted pursuant to this section shall excuse any further obligation under Section 20104.4 to mediate after litigation has been commenced.

9-1.17D(4)(e) This section does not preclude a public entity from requiring arbitration of disputes under private arbitration or the Public Works Contract Arbitration Program, if mediation under this section does not resolve the parties' dispute.

9-1.17D(5) Failure by the public entity to respond to a claim from a contractor within the time periods described in this subdivision or to otherwise meet the time requirements of this section shall result in the claim being deemed rejected in its entirety. A claim that is denied by reason of the public entity's failure to have responded to a claim, or its failure to otherwise meet the time requirements of this section, shall not constitute an adverse finding with regard to the merits of the claim or the responsibility or qualifications of the claimant.

9-1.17D(6) Amounts not paid in a timely manner as required by this section shall bear interest at 7 percent per annum.

9-1.17D(7) If a subcontractor or a lower tier subcontractor lacks legal standing to assert a claim against a public entity because privity of contract does not exist, the contractor may present to the public entity a claim on

Replace the last paragraph of section 12-4.01 with:

Notify the local authorities in writing of your intent to begin work at least 5 days before work is to start. Submit a copy of the notice and send it to the local authorities before commencement of construction. Cooperate with local authorities to handle traffic through the area and make arrangements to keep the working area clear of parked vehicles. The local authorities must consist of:

1. Humboldt County Sheriff Department - (707) 445-7251

Replace "Reserved" in section 12-5 with:

12-5.01 GENERAL

Section 12-5 includes specifications for closing traffic lanes with stationary lane closures on 2-lane, two-way highways.

A traffic control system for a closure includes the temporary traffic control devices described as part of the traffic control system. The temporary traffic control devices must comply with section 12-3.

12-5.02 MATERIALS

Not Used

12-5.03 CONSTRUCTION

Whenever components of the traffic control system are displaced or cease to operate or function as specified from any cause, immediately repair the components to the original condition or replace the components and restore the components to the original location.

For a stationary lane closure made only for the work period, remove the components of the traffic control system from the traveled way and shoulder, except for portable delineators placed along open trenches or excavation adjacent to the traveled way at the end of each work period. You may store the components at selected central locations designated by the Engineer within the limits of the highway.

12-5.04 PAYMENT

A traffic control system for a lane closure is paid for as traffic control system. Flagging costs are paid for as specified in section 12-1.03.

The requirements in section 4-1.05 for payment adjustment do not apply to traffic control system. Adjustments in compensation for traffic control system will be made for an increase or decrease in traffic control work if ordered and will be made on the basis of the cost of the necessary increased or decreased traffic control. The adjustment will be made on a force account basis for increased work and estimated on the same basis in the case of decreased work.

A traffic control system required by change order work is paid for as a part of the change order work.

Add to section 12:

12-9 TEMPORARY DETOUR

12-9.01 GENERAL

Furnish and install temporary detour as shown.

Cold plane AC pavement must comply with section 15-2.02B(3).

Earthwork must comply with section 19.

Aggregate Base must comply with section 26.
Hot Mix Asphalt must comply with section 39.
Mirafi HP370 Geotextile or approved equal must comply with section 88-1.02B.
Traffic Stripes and pavement markings must comply with Section 84.
Signs shall comply with section 12-3.06.

Concrete modular block (shoring system) or approved equal must comply with manufacturers requirements. Contractor must submit shop drawings to Engineer for review.
Temporary communication conduit shall comply with section 86.

See section 48-6 for temporary bridge.

Maintenance of the detour and removal of the detour when no longer needed must be considered as included in the contract lump sum price paid for Temporary Detour including Cold Plane AC Pavement, Improt Borrow, Roadway Excavation, Geotextle, Hot Mix Asphalt, Abggregate Base, Traffic Striping and pavement markings, signs, and concrete modular block (shoring system), and no additional compensation will be allowed therefor.

^^

13 WATER POLLUTION CONTROL

Add to section 13-1.01A:

The following RWQCBs will review the authorized SWPPP:

1. North Coast RWQCB Region 1

Add to section 13-3.01A:

The project is risk level 2.

Replace section 13-4.03E(12) with:

13-4.03E(12) Temporary Stream Diversion

13-4.03E(12)(a) General

Furnish and install temporary stream diversion as shown on the plans.

Plastic pipe must comply with section 64.

Silt Exclusion Fence must comply with the section 13-10.03F and as shown on the plans.

Straw bales must comply with section 13-10.02H.

Filter fabric must comply with section 88-1.02B.

The construction of the temporary stream diversion must comply with section 5-1.20B.

Earthwork must comply with section 19-1.03.

Rock shall be washed, river run gravel (3"-6").

Fish Exclusionary Fence shall be installed at a location directed by Engineer. Fish Exclusionary Fencing shall have a screen opening of 3/32" or smaller (measured diagonally).

The temporary culvert must be capable of discharging a quantity of water equivalent to the size of culvert shown on the plans. Adequacy as to equivalent strength and capacity shall be subject to approval by the Engineer.

Final grading of Williams Creek shall conform to the plans.

13-4.03E(12)(b) Payment

Maintaining the temporary stream diversion, grading of the temporary stream diversion, and removal and disposal of materials when temporary stream diversion is no longer needed must be considered as included in the contract lump sum price paid and no additional compensation will be allowed therefor.

Grading of Williams Creek shall be paid for as Roadway Excavation.

Replace section 13-11 with:

13-11 WATER QUALITY MONITORING

13-11.01 GENERAL

Section 13-11 includes specifications for monitoring water quality during the following construction activities:

1. Temporary stream diversion

The receiving water for this project is Williams Creek.

13-11.02 WATER QUALITY MONITOR

13-11.02A General

Assign a water quality monitor (WQM) to collect water samples and record water quality data. The WQM must be responsible for generating and submitting water quality reports.

Within 7 days after Contract approval, submit the WQM qualifications including training and experience in collecting and analyzing water quality samples.

The WQM must have the same qualifications as the WPC manager including the requirements for QSP and must have training and experience in collecting and analyzing water quality samples. The WQM may be the same person as the WPC manager.

If other personnel will be collecting water quality samples, their training must include:

1. SAP review
2. Health and safety review
3. Sampling simulations

If there is an unauthorized discharge, the WQM must immediately notify the Engineer within 6 hours.

13-11.02B Visual Inspections

The WQM must perform a visual inspection after each:

1. Storm event
2. Nonstormwater discharge as follows:
 - 2.1. Observe receiving waters:
 - 2.1.1. 24 hours before beginning in-water work including the installation of clear water diversions
 - 2.1.2. At least 4 times daily during in-water work activities including the installation, operation, and removal of clear water diversions
 - 2.2. Observe receiving waters for the presence of floating and suspended materials, sheen on the surface, discoloration, turbidity, odors, and sources of observed pollutants
 - 2.3. Observe the job site for the presence of authorized and unauthorized nonstormwater discharges and their sources. Unauthorized discharges to surface waters include:
 - 2.3.1. Soil, silt, and sand
 - 2.3.2. Bark, sawdust, and slash
 - 2.3.3. Rubbish and debris
 - 2.3.4. Cement, concrete, and concrete washings
 - 2.3.5. Oil and petroleum products
 - 2.3.6. Welding slag
 - 2.3.7. Other organic or earthen materials

The WQM must prepare a visual inspection report for each storm event and nonstormwater discharge. Each visual inspection report must include:

1. Name of personnel performing the inspection, inspection date, and date the inspection report is completed
2. Storm and weather conditions
3. Locations and observations
4. Corrective actions taken

Retain visual inspection reports at the job site.

13-11.03 WATER QUALITY SAMPLING AND ANALYSIS DAY

Water quality sampling and analysis day includes activities such as preparation, collection, analysis, and reporting of water quality samples.

This project is subject the water quality objectives (WQO) shown in the following table:

Water Quality Objectives

Parameter	Test Method	Detection limit (min)	Units	WQO
Turbidity (during activities for in-water work)	Field test with calibrated portable instrument (Measured at downstream sampling location)	1	NTU	Must not exceed 20 percent above natural background
pH	Field test with calibrated portable instrument (Measured at downstream sampling location)	0.2	pH	Lower WQO = 6.5 Upper WQO = 8.5 And any change greater than 0.5 units from natural background
Temperature	Field test with calibrated portable instrument	0.1	°F	Must not be increased 5 degrees above natural background
Dissolved oxygen	Field test with calibrated portable instrument	1	mg/L	Must not be reduced below 7 mg/L

Water Quality Objectives

Parameter	Test Method	Detection limit (min)	Units	WQO
pH	Field test with calibrated portable instrument	0.2	pH	Lower NAL = 6.5 Upper NAL = 8.5 And any change greater than 0.5 units from natural background
Turbidity	Field test with calibrated portable instrument	1	NTU	20 percent above natural background
Temperature	Field test with calibrated portable instrument	1	°F	1 degree above natural background
Dissolved oxygen	Field test with calibrated portable instrument	1	mg/L	Must not be reduced below 7 mg/L
Total dissolved solids	Field test with calibrated portable instrument ^a	1	mg/L	Greater than 100 mg/L
Specific conductance	Field test with calibrated portable instrument	0.1	μΩ	Must not exceed 175 μΩ at 77 °F

^a Portable instrument provides an estimate of Total Dissolved Solids (TDS).

Perform water quality sampling whenever a project activity, conducted within waters of the State, has the potential to mobilize sediment or alter background conditions within waters of the State. Perform surface water quality sampling when:

1. Conducting in-water work
2. Work activities result in materials reaching receiving waters
3. Work activities result in the creation of a visible plume in receiving waters

Comply with the equipment manufacturer's recommendation for sample collection, analysis methods, and equipment calibration.

At least 24 hours before starting in-water work:

1. Establish locations for water quality sampling:
 - 1.1. Upstream of the effluent discharge point or location of in-water work by no more than 50 feet.
 - 1.2. Effluent discharge point including location of in-water work.
 - 1.3. Downstream of the effluent discharge point or location of in-water work between 35 and 50 feet.
2. Conduct water quality sampling to document background conditions for upstream, effluent, and downstream locations. Sample for each WQO shown in the table titled "Water Quality Objectives."
3. Estimate water flow.

Whenever conducting in-water work including the installation of a clear water diversion, conduct water quality sampling:

1. At least 4 times daily for each water quality objective
2. At upstream, effluent, and downstream locations

If sample results exceed a WQO, immediately notify the Engineer within 30 minutes and:

1. Conduct water quality sampling every hour until measurements comply with WQOs
2. Measure the distance from the effluent location to the downstream extent of the exceedance
3. Obtain photos of the tributary upstream, downstream, and at the location of in-water work
4. If BMPs are installed, repaired, or modified to control the source of the exceedance, monitor the activity and document with samples, photos, and a brief summary

You are not required to physically collect samples under the following conditions:

1. During dangerous weather conditions such as flooding or electrical storms
2. Outside of normal working hours

If downstream samples show levels outside of the acceptable range and indicate a possible WQO exceedance, assess WPC practices, site conditions, and surrounding influences to determine the probable cause for the increase.

Retain calibration logs, water quality sampling documentation, and analytical results at the job site.

13-11.04 WATER QUALITY MONITORING REPORT

13-11.04A General

Submit a monthly water quality monitoring report by the 7th of the month for monitoring work conducted during the previous month. The report must include:

1. Visual inspection reports
2. If in-water work was done, the following field sampling results and inspections:
 - 2.1. Analytical methods, reporting units, and detection limits
 - 2.2. Date, location, time of sampling, visual observation, photos, and measurements
 - 2.3. Estimate of water flow
 - 2.4. Calibration logs for field monitoring equipment
3. If a storm event generates visible runoff, include visual inspections and sampling results with:
 - 3.1. Date, location, and time of visual observation
 - 3.2. Photos of areas disturbed by project activities including excess materials disposal areas
 - 3.3. Photos showing disturbed soil areas and documenting compliance for erosion control and revegetation measures including soil stabilization and sediment control BMPs
4. Summary of exceedance
5. Summary of corrective actions

13-11.04B Water Quality Objective Exceedance Report

If a WQO is exceeded, the WQM must:

1. Notify the Engineer by phone or electronic media within 30 minutes after WQO is exceeded
2. Submit a WQO exceedance report within 6 hours after WQO is exceeded

The report must include:

1. Field sampling results and inspections including:

- 1.1. Analytical methods, reporting units, and detection limits
 - 1.2. Date, location, time of sampling, visual observation, photos, and measurements
 - 1.3. Estimate of water flow
2. Description of BMPs and corrective actions taken to manage WQO exceedance

13-11.04C Additional Reports

Not Used

13-11.05 WATER QUALITY ANNUAL REPORT

Not Used

14 ENVIRONMENTAL STEWARDSHIP

Replace "Reserved" in section 14-1.04 with:

14-1.04 WATERS OF THE UNITED STATES, INCLUDING WETLANDS

14-1.04A General

Prior to any discharge of dredged or fill material into "waters of the United States," including wetlands, authorization under a Nationwide or Individual Permit shall be obtained from the Corps. For any features determined not to be subject to Corps jurisdiction, during the verification process, authorization to discharge shall be obtained from the RWQCB. For fill requiring a Corps permit, water quality certification shall be obtained from the RWQCB prior to discharge of dredged or fill material.

Prior to any activities that would obstruct the flow of, or alter the bed, channel, or bank of any intermittent or ephemeral creeks, notification of streambed alteration shall be submitted to the DFW; and, if required, a streambed alteration agreement shall be obtained from DFW.

Prior to any impacts to wetlands or areas considered sensitive within the Coastal Zone, authorization under a Coastal Development Permit shall be obtained from Humboldt County Planning Department, which is appealable to the California Coastal Commission.

Construction activities that will affect "water of the United States" shall be conducted during the dry season to minimize erosion.

Any monitoring, maintenance, and reporting required by the regulatory agencies (i.e., Corps, RWQCB, and DFW) shall be implemented and completed. All measures contained in the permits or associated with agency approvals shall be implemented.

14-1.04B Materials

Not Used

14-1.04C Construction

Not Used

14-1.04D Payment

Full compensation for furnishing all labor, materials, tools, equipment and incidentals, and for doing all work involved in avoidance and minimization efforts associated with other waters of the United States, including wetlands must be considered as included in the various items of work and no additional compensation will be allowed therefor.

Add to section 14-1.05:

14-1.05 AVOIDANCE AND MINIMIZATION EFFORTS

14-1.05A General

Chinook salmon are nonexistent in Williams Creek. Future presence and utilization is unknown at this time.

Coho salmon are nonexistent in Williams Creek. Future presence and utilization is unknown at this time.

Steelhead are nonexistent in Williams Creek. Future presence and utilization is unknown at this time.

14-1.05 (1)A TEMPORARY CHANNEL CROSSING

The project will be constructed during the summer/early fall months which will help minimize the release of fine sediment to points downstream and into the Salt River.

Disturbance or removal of vegetation will not exceed the minimum necessary to complete the projects.

The "area of disturbance" will be restricted to only those areas necessary to complete the project.

All (light/heavy) equipment entering sensitive areas will be inspected and cleaned at an offsite location prior to being transported to the work site.

Equipment will be inspected for leaks before each shift, throughout the work shift, and at end of shift.

Equipment parking, maintenance, and fueling will occur at designated staging areas only.

Light equipment (i.e., generators, welders, and pumps) as well as heavy equipment will use drip pans or other devices (i.e., absorbent blankets, sheet barriers, or other materials) as needed to prevent contaminants from reaching the stream or ground water.

Appropriate sized spill kits will be kept onsite through the duration of each project. In the event of a spill, DFW will be notified and consulted regarding clean-up procedures.

Containment vessels and clean-up BMP's will remain onsite through completion of the project.

All bare mineral soil exposed in conjunction with construction, maintenance, or repair, will be treated for erosion prior to the onset of any rainfall event capable of generating run-off or at the end of the yearly work period, whichever comes first.

Channel access route(s) and areas designated for equipment staging, maintenance, and fueling will be groomed, bermed, and treated with straw mulch and seeded if necessary to minimize the potential for the release of fine sediment to the stream or nearby upland area(s). Erosion control criteria will consist of at least 2 to 4 inches of straw mulch and 100 lbs/acre equivalent barley seed in those instances when reseeding is applicable. No annual, or Italian, ryegrass (*Lolium multiflorum*) shall be used.

All construction debris associated with the projects will be removed from the site and disposed of appropriately.

Regular site inspections (monitoring) will occur the winter following construction, confirming that the appropriate BMP's are in place and functioning as intended.

Inadequacies will be evaluated and corrections made in a timely manner.

14-1.05 (1)B Materials

Not Used

14-1.05 (1)C Construction

Not Used

14-1.05 (1)D Payment

Full compensation for furnishing all labor, materials, tools, equipment and incidentals, and for doing all work involved in avoidance and minimization efforts associated with furnishing and installing a temporary

channel crossing must be considered as included in the various items of work and no additional compensation will be allowed therefor.

Replace the 1st item of 1st paragraph of section 14-2.02A with:

1. Stop all work within 50-foot radius of the discovery

Add to section 14-2.02A:

If cultural resources, such as chipped or ground stone, historic debris, bulding foundations, or bone discovered during ground-disturbance activities, work shall be stopped within 60 feet of the discovery, per the requirements of the CEQA (Title 14 CCR 15064.5 (f) and Section 106 (36 CFR 800.13). Work near the archaeological finds shall not resume until County's professional archaeologist, who meets the Secretary of the Interior's Standards and Guidelines, has evaluated the materials and offered recommendations for further action.

If human remains are discovered during project construction, work will stop at the discovery location, within 60 feet, and any nearby area reasonably suspected to overlie adjacent human remains. The Humboldt County coroner will be contacted to determine if the cause of death must be investigated. If the coroner determines that the remains are of Native American origin, it is necessary to comply with state lawa relating to the disposition of Native American burials, which fall within the jurisdiction of the Native American Heritage Commission (NAHC). The coroner will contact the NAHC. The descendants or most likely descendants of the deceased will be contacted, and work will not resume until they have made a recommendation to the landowner or the person responsible for the excavation work for means of treatment and disposition, with appropriate dignity, of the human remains and any associated grave goods, as provided in Public Resources Code Section 5097.98. Work may resume if NAHC is unable to identify a descendant or the descendant failed to make a recommendation.

Replace section 14-6.02 with:

14-6.02 SPECIES PROTECTION

14-6.02A General

Section 14-6.02 includes specifications for protecting regulated species or their habitat. This project is within or near habitat for regulated species shown in the following table:

Species Name

Coastal Cutthroat Trout
Hoary bat
Pallid bat

14-6.02B Material

Not Used

14-6.02C Construction

14-6.02C(1) General

Not Used

14-6.02C(2) Protective Radius

Upon discovery of a regulated species, stop construction activities within a radius of discovery as determined by the project biologist. Immediately notify the Engineer. Do not resume activities until receiving notification from the Engineer.

14-6.02C(3) Protocols

Not Used

14-6.02C(4) Biological Resource Information

Not Used

14-6.02C(5) Protection Measures

Have all construction personnel complete environmental awareness training on the permit requirements and the project area wildlife species information before starting work. Department's biologist will provide the training at the Engineer's field office. Notify the Engineer at least 45 business days before starting work to coordinate the preconstruction training.

Do not start vegetation removal or ground-disturbing activities until you receive approval from Engineer.

Establish a construction-free buffer zone around the activity site per section 14-6.03 when an active nest is found. Do not start construction activities within the buffer zone until you receive approval from Engineer.

Stop work immediately when determined by Department's biologist that the work has a potential to disturb the protected species when they are found during construction.

14-6.02C(6) Monitoring Schedule

Not Used

14-6.02D Payment

Not Used

Add to section 14-6.02:

14-6.02 (1)A OTHER MAMMALS

The removal of mature conifer trees is not anticipated.

The project will not infringe into habitat preferred by Sonoma tree vole, Pallid bat, and Hoary bat.

The bridge will be inspected for bat activity prior to any bridge work; if bats are found inhabiting the bridge, DFW staff will be consulted with on how to manage the bats.

14-6.02 (1)B Materials

Not Used

14-6.02 (1)C Construction

Not Used

14-6.02 (1)D Payment

Full compensation for furnishing all labor, materials, tools, equipment and incidentals, and for doing all work involved in avoidance and minimization efforts associated with other mammals must be considered as included in the various items of work and no additional compensation will be allowed therefor.

Replace the 3rd paragraph of section 14-6.03A with:

The Department anticipates nesting or attempted nesting by migratory and nongame birds from March 1 to August 30.

County's Biologist will remove all unfinished swallow nests. Reschedule any activities that would disturb the occupied nests until nesting activities cease.

Replace "Reserved" in Section 14-6.10 with:

14-6.10 RAPTORS

14-6.10A General

The project will be constructed during the summer and into early fall, a time when most young of the year have likely fledged.

If nesting habitat is present, then pre-construction surveys for nesting raptors shall be conducted by a qualified biologist to ensure that no nests will be disturbed during project implementation. At least one survey should be conducted no more than 15 days prior to the initiation of construction activities. During this survey, the County's biologist must inspect all trees immediately adjacent to the impact areas for raptor nests. If an active raptor nest is found close enough (i.e., within 50 ft) to the construction area to be disturbed by these activities, the biologist (in consultation with the DFW) will determine the extent of a construction-free buffer zone to be established around the nest.

Any potential nesting habitat (e.g., shrubs and trees) that will be removed by the project should be removed before the onset of the nesting season (March 1 through August 30), if practicable. This will help preclude nesting and substantially decrease the likelihood of direct impacts.

14-6.10B Materials

Not Used

14-6.10C Construction

Not Used

14-6.10D Payment

Full compensation for furnishing all labor, materials, tools, equipment and incidentals, and for doing all work involved in avoidance and minimization efforts associated with furnishing and installing a temporary channel crossing must be considered as included in the various items of work and no additional compensation will be allowed therefor.

Replace "Reserved" in Section 14-6.11 with:

14-6.11 SONGBIRDS

14-6.11A General

Grading and other construction activities will be scheduled to avoid the nesting season to the extent possible. The nesting season for these species extends from March through August. If construction occurs outside of the breeding season, no further mitigation is necessary. If the breeding season cannot be completely avoided, the following mitigations will be implemented.

A qualified biologist will conduct a minimum of one pre-construction survey for songbirds within the API, including the bridge for swallow activity. The surveys should be conducted no more than 15 days prior to the initiation of construction in any given area. The preconstruction survey should be used to ensure that no nests of these species occur within or immediately adjacent to the API and would be disturbed during project implementation. If an active nest is found, the biologist will either determine the extent of a

construction-free buffer zone to be established around the nest or postpone the project until the young have fledged.

Regarding swallow nesting underneath the bridge: Previous surveys have not identified any signs of swallow activity (old/active nests) at the bridge site. However, if pre-construction surveys show swallow activity at the bridge site, the County will take appropriate measures to remove nests before they become active. These activities will need to be authorized by DFW.

Any potential nesting habitat (e.g., shrubs and trees) that will be removed by the project should be removed before the onset of the nesting season (March 1 through August 30), if practicable. This will help preclude nesting and substantially decrease the likelihood of direct impacts.

14-6.11B Materials

Not Used

14-6.11C Construction

Not Used

14-6.11D Payment

Full compensation for furnishing all labor, materials, tools, equipment and incidentals, and for doing all work involved in avoidance and minimization efforts associated with songbirds must be considered as included in the various items of work and no additional compensation will be allowed therefor.

^^

15 EXISTING FACILITIES

Add to section 15-2.02B(2):

Payment for obliterate surfacing must be considered as included in the payment of various items of work and no additional payment will be made therefore.

Replace section 15-2.02B(3) with:

15-2.02B(3) Cold Planing Asphalt Concrete Pavement

15-2.02B(3)(a) General

Schedule cold planing activities to ensure that cold planing, placement of HMA, and reopening the area to traffic is completed during the same work shift:

If you do not complete HMA placement before opening the area to traffic, you must:

1. Construct a temporary HMA taper to the level of the existing pavement.
2. Place HMA during the next work shift.
3. Submit a corrective action plan that shows you will complete cold planing and placement of HMA in the same work shift. Do not resume cold planing activities until the corrective action plan is authorized.

15-2.02B(3)(b) Materials

Use the same quality of HMA for temporary tapers that is used for the HMA overlay or comply with the specifications for minor HMA in section 39.

15-2.02B(3)(c) Construction

15-2.02B(3)(c)(i) General

Do not use a heating device to soften the pavement.

The cold planing machine must be:

1. Equipped with a cutter head width that matches the planing width. If the cutter head width is wider than the cold plane area shown, you may request to use the wider cutter head. Do not cold plane with the wider cutter head unless authorized.
2. Equipped with automatic controls for the longitudinal grade and transverse slope of the cutter head and:
 - 2.1. If a ski device is used, it must be at least 30 feet long, rigid, and a 1-piece unit. The entire length must be used in activating the sensor.
 - 2.2. If referencing from existing pavement, the cold planing machine must be controlled by a self-contained grade reference system. The system must be used at or near the centerline of the roadway. On the adjacent pass with the cold planing machine, a joint-matching shoe may be used.
3. Equipped to effectively control dust generated by the planing operation.
4. Operated such that no fumes or smoke is produced.

Replace broken, missing, or worn machine teeth.

15-2.02B(3)(c)(ii) Grade Control and Surface Smoothness

Furnish, install, and maintain grade and transverse slope references.

The depth, length, width, and shape of the cut must be as shown or as ordered. The final cut must result in a neat and uniform surface. Do not damage the remaining surface.

The completed surface of the planed asphalt concrete pavement must not vary more than 0.02 foot when measured with a 12-foot straightedge parallel with the centerline. With the straightedge at right angles to the centerline, the transverse slope of the planed surface must not vary more than 0.03 foot.

Where lanes are open to traffic, the drop-off of between adjacent lanes must not be more than 0.15 foot.

15-2.02B(3)(c)(iii) Temporary HMA Tapers

If a drop-off between the existing pavement and the planed area at transverse joints cannot be avoided before opening to traffic, construct a temporary HMA taper.

Completely remove temporary tapers before placing permanent surfacing.

15-2.02B(3)(c)(iv) Removal of Planed Material

Remove cold planed material concurrent with planing activities so that removal does not lag more than 50 feet behind the planer.

15-2.02B(3)(d) Payment

Payment for removal of pavement markers, thermoplastic traffic stripe, painted traffic stripe, and pavement marking within the area of cold planing is included in the payment for cold plane asphalt concrete pavement of the types shown in the Bid Item List.

Add to section 15-2.02J:

All salvagable roadside signs including posts shall be delivered to the Loleta Maintenance station located at 75 Hookton Cemetery Road, Loleta CA.

Replace section 15-2.09E with:

15-2.09E Relocate Mailbox

Relocate the mail box to the location shown on the plans. Mount mailboxes on posts that are set in the ground. Do not use posts concreted in buckets for temporary supports.

^^

20 LANDSCAPE

Replace the 1st and 2nd paragraph in Section 20-3.01B(b)(iii) of the RSS for Section 20 with:

Harvest planting stakes from on-site or nearby sources.

A cutting must be:

1. Reasonably straight
2. 12 to 18 inches in length
3. 3/4 to 3 inch in diameter at the base of the cutting

Add to the 2nd paragraph in Section 20-3.03C(3)(d)(i) of the RSS for Section 20:

Soak stakes for 5-7 days prior to installation.

Add to the 1st paragraph in Section 20-3.03C(3)(d)(ii) of the RSS for Section 20:

Hole must extend at least 6 inches below top of water table.

Replace the 5th paragraph in Section 20-3.03C(3)(d)(ii) of the RSS for Section 20:

Plant the base of the cutting from 10 to 15 inches deep and have from 2 to 5 bud scars exposed above the ground. If more than 5 bud scars are exposed, trim-off the excess willow cutting length.

Add to Section 20-3.03C(3)(d)(ii) of the RSS for Section 20:

Place willow stakes 10-foot on center. Stagger willow stake rows by 5 feet parallel to the road.

Add between the 2nd and 3rd paragraphs of section 20-4.01A of the RSS for section 20:

Minimum-bid plant establishment work is work (1) that is described as plant establishment work and (2) for which a minimum item total must be bid.

Add to the end of section 20-4.01A of the RSS for section 20:

Replace the 3rd paragraph of section 20-4.03A of the RSS for section 20 with:

You are not required to trim or mow turf areas.

Replace the 6th paragraph of section 20-4.03A of the RSS for section 20 with:

You are not required to remove foliage protectors.

Add to the end of section 20-4.03C of the RSS for section 20:

Add to section 20-4.01A of the RSS for section 20:

Monitoring and maintenance shall occur at a minimum of ninety (90) days. Replace dead, dying trees and plants with new ones during the monitoring and maintenance period. Monitoring shall include photo documentation and field notes to be included in annual reports until the final report is developed.

^^

21 EROSION CONTROL

Replace "Reserved" in Section 21-1.02L with:

Hydroseed work shall consist of applying erosion control materials, consisting of a mixture of fiber, seed, tackifier, commercial fertilizer and water. The mixture shall be applied to embankment and excavation slopes and other graded or disturbed areas of the project including any borrow or disposal sites as determined by the Engineer.

Seed shall consist of the following native species or equivalent as approved by Engineer. If the adjacent property is certified organic by the USDA, the Contractor shall obtain certified organic seed. In the event organic seed suitable for erosion control or the adjacent pasture is not available then conventional untreated seed may be used.

<u>Botanical Name (Common Name)</u>	<u>Percentage Purity (minimum)</u>	<u>Percentage Germination (minimum)</u>	<u>Lbs. Per Acre</u>
Bromus Carinatus (California Brome)	95	95	35
Vulpia microstachys (Small Fescue or Three Weeks Fescue)	98	85	6
Trifolium wildenovii (Tomcat Clover)	98	80	4

Seed shall be mixed on the project site in the presence of the Engineer.

The erosion control materials shall be mixed and applied in the following proportions:

<u>Material</u>	<u>Lbs. per Acre (Slope Measurement)</u>
Fiber	1500
Seed	45
Commercial Fertilizer	300

Tackifier conforming to section 21-1.02F shall be incorporated in the mix at the rate recommended by the manufacturer.

The mixture shall be applied within 60 minutes after the seed has been added to the mixture.

^^

DIVISION IV SUBBASES AND BASES

26 AGGREGATE BASES

Add to section 26-1.02B:

The aggregate shall have at least 50% crushed particles with at least one fractured face.

^^

DIVISION V SURFACING AND PAVEMENTS

39 HOT MIX ASPHALT

Replace Section 39 Asphalt Concrete with Section 39 Hot Mix Asphalt, Standard Specifications 2010

Add to section 39-1.01 (2010 Std. Specs):

Produce and place HMA Type A under the METHOD construction process.

Add to section 39-1.02C (2010 Std. Specs):

Asphalt binder used in HMA Type A must be PG 64-16.

Add to section 39-1.02E (2010 Std. Specs):

Aggregate used in HMA Type A must comply with the 1/2-inch HMA Types A and B gradation.

Replace "Reserved" in section 39-2.02C of the RSS for section 39 with:

The grade of asphalt binder for Type A HMA must be PG 64-16.

Add to the beginning of section 39-2.03 of the RSS for section 39:

Use a material transfer vehicle when placing Type A HMA if:

The Contractor shall install and maintain wood wheel guards and wood handrails to the satisfaction of the Engineer. Damaged wheel guards and handrails shall be immediately replaced and shall be maintained in good working order as long as the detour is in use.

As a minimum, wheel guards shall consist of 4 by 6 timber over 4 by 6 blocks bolted with two 1/2-in bolts at 4' O.C. to the temporary bridge. It is the Contractors responsibility to provide wheel guards that will adequately protect the public.

As a minimum, handrails shall consist of 3 rails of 2 by 4 lumber attached to 4 by 6 posts at 5' O.C. Rails are bolted to the posts with two 3/8-in bolts. Posts are secured to the temporary bridge with four 1/2-in bolts. The height of the handrail is 42 inches. It is the Contractors responsibility to provide hand railing that will adequately protect the public.

48-6.04 PAYMENT

The lump sum payment for installation of a temporary bridge includes both the construction and removal of the temporary bridge including placing concrete grade beams and flatcar or approved equal, including wheel guards and guard railing, removing the temporary bridge and grade beams and restoring the ramp areas to pre-project condition.

^^

DIVISION IX TRAFFIC CONTROL FACILITIES

80 FENCES

Add to section 80-1.07:

Temporary fence shall be constructed with metal "T" posts and 5-strands barbed wire.

Replace "Reserved" in section 80-2.02A with:

Posts must be metal.

Add to section 80-2.02B:

Paint posts red.

Replace section 80-2.04 with:

Payment for installing gate provided by owner is included in the payment for reset gate.

^^

83 RAILINGS AND BARRIERS

1. Quantity of HMA to be paved is greater than 1,000 tons
2. Any of the following exists:
 - 2.1. Paving is allowed and the atmospheric temperature is below 70 degrees F.
 - 2.2. Time from discharge to truck at the HMA plant until transfer to the paver's hopper is 90 minutes or greater.

DIVISION VI STRUCTURES

48 TEMPORARY STRUCTURES

Replace section 48-6 with:

48-6 TEMPORARY BRIDGE (DETOUR)

48-6.01 GENERAL

48-6.01A Summary

Section 48-6 includes specifications for constructing a detour including a temporary bridge.

The Contractor shall furnish and install a temporary bridge. Furnish and install a rail flatcar bridge and provide two concrete grade beams. The Contractor may submit an alternative temporary bridge to the Engineer for approval.

A detour is to be constructed at the bridge site as shown on the plans. Work in the river or stream areas shall conform to all requirements of the controlling agencies as listed on permits or in these special provisions. Material required to construct fills shall be an imported river gravel from a source approved by the Engineer. Where shown on the plans a suitable engineering fabric shall be placed under the fill to protect the original ground surface. Upon completion of the detour use, all temporary fills shall be completely removed and the original grade restored.

A rail flatcar bridge or approved equal is to be supplied to the site by Contractor. The bridge may require re-installation of, or new, curbs and/or railing. All work to prepare the bridges for traffic following installation will be considered to be a part of constructing the detour.

48-6.01B Definitions

Not Used

48-6.01C Submittals

Submit Shop Drawings of the temporary detour and temporary bridge for Engineer's review.

48-6.02 MATERIALS

Not Used

48-6.03 CONSTRUCTION

The temporary bridge is to be placed at the detour location by the Contractor.

The Contractor is responsible for any damage to the temporary bridge caused by his/her operations.

PROPOSAL
TO
THE COUNTY OF HUMBOLDT
FOR

WILLIAMS CREEK BRIDGE REPLACEMENT ON GRIZZLY BLUFF ROAD
PROJECT NO.: BRLS-5904(127)
CONTRACT NO.: 594209

Name of Bidder: _____
(Name must be exactly as it appears [or will appear] on Contractor's license)

Business Address: _____

Telephone No.: _____

Place of Residence: _____

The work for which this proposal is submitted is for construction in accordance with the special provisions (including the payment of not less than the State general prevailing wage rates or Federal minimum wage rates), the project plans described above, including any addenda thereto, the contract annexed hereto and also in accordance with the California Department of Transportation Standard Plans dated 2010, the Standard Specifications dated 2010, and the Labor Surcharge and Equipment Rental Rates in effect at the time the work is performed.

Bids are to be submitted for the entire work. The amount of the bid for comparison purposes will be the total of all items of the base bid or base bid plus additive(s) if the additive(s) is awarded.

The bidder shall set forth for each unit basis item of work a unit price and a total for the item, and for each lump sum item a total for the item, all in clearly legible figures in the respective spaces provided for that purpose. In the case of unit basis items, the amount set forth under the "Item Total" column shall be the product of the unit price bid and the estimated quantity for the item.

In case of discrepancy between the unit price and the total set forth for a unit basis item, the unit price shall prevail, except as provided in (a) or (b), as follows:

- (a) If the amount set forth as a unit price is unreadable or otherwise unclear, or is omitted, or is the same as the amount as the entry in the item total column, then the amount set forth in the item total column for the item shall prevail and shall be divided by the estimated quantity for the item and the price thus obtained shall be the unit price;
- (b) (Decimal Errors) If the product of the entered unit price and the estimated quantity is exactly off by a factor of ten, one hundred, etc., or one-tenth, or one-hundredth, etc. from the entered total, the discrepancy will be resolved by using the entered unit price or item total, whichever most closely approximates percentagewise the unit price or item total in the County of Humboldt's Final Estimate of cost.

If both the unit price and the item total are unreadable or otherwise unclear, or are omitted, the bid may be deemed irregular. Likewise if the item total for a lump sum item is unreadable or otherwise unclear, or is omitted, the bid may be deemed irregular unless the project being bid has only a single item and a clear, readable total bid is provided.

Add to section 83-1.02B:

Treated wood must be painted with a double-coating of durable, non-copper marine paint specifically designed for the wear and weather of outdoor marine environments.

Add to section 83-1.02B(2):

The offset from the face of the Type WB-31 transition railing to the hinge point must be at least 3'-0".

Replace section 83-1.02C(3) with:

83-1.02C(3) Alternative Flared Terminal System

Alternative flared terminal system must be furnished and installed as shown on the plans and under these special provisions.

The allowable alternatives for a flared terminal system must consist of one of the following or a Department-authorized equal.

1. TYPE FLEAT TERMINAL SYSTEM - Type FLEAT terminal system must be a Flared Energy Absorbing Terminal 350 manufactured by Road Systems, Inc., located in Big Spring, Texas, and must include items detailed for Type FLEAT terminal system shown on the plans. The Flared Energy Absorbing Terminal 350 can be obtained from the distributor, Universal Industrial Sales, P.O. Box 699, Pleasant Grove, UT 84062, telephone (801) 785-0505 or from the distributor, Gregory Industries, Inc., 4100 13th Street, S.W., Canton, OH 44708, telephone (330) 477-4800.
2. TYPE QUADTREND 350 TERMINAL SYSTEM - Type QUADTREND 350 terminal system must as manufactured by Energy Absorbitions Systems, Inc., and must include items detailed for QUADTREND 350 terminal system shown on the plans. The QUADTREND 350 terminal system can be obtained from the distributor, Traffic Management Inc., 2435 Lemon Avenue, Signal Hill, CA 90755, telephone 916-387-6300 or from the manufacturer, Energy Absorption Systems, Inc., 70 W Madison Street, Suite 2350 Chicago, IL 60602, telephone (312) 467-6750

Submit a certificate of compliance for terminal systems.

Terminal systems must be installed under the manufacturer's installation instructions and these specifications. Each terminal system installed must be identified by painting the type of terminal system in neat black letters and figures 2 inches high on the backside of the rail element between system posts numbers 4 and 5.

For Type FLEAT terminal system, the soil tubes must be, at the Contractor's option, driven with or without pilot holes, or placed in drilled holes. Space around the steel foundation tubes must be backfilled with selected earth, free of rock, placed in layers approximately 4 inches thick and each layer must be moistened and thoroughly compacted. Wood posts must be inserted into the steel foundation tubes by hand. Before the wood terminal posts are inserted, the inside surfaces of the steel foundation tubes to receive the wood posts must be coated with a grease that will not melt or run at a temperature of 149 degrees F or less. The edges of the wood posts may be slightly rounded to facilitate insertion of the post into the steel foundation tubes.

After installing the terminal system, dispose of surplus excavated material in a uniform manner along the adjacent roadway where designated by the Engineer.

Symbols such as commas and dollar signs will be ignored and have no mathematical significance in establishing any unit price or item total or lump sums. Written unit prices, item totals and lump sums will be interpreted according to the number of digits and, if applicable, decimal placement. Cents symbols also have no significance in establishing any unit price or item total since all figures are assumed to be expressed in dollars and/or decimal fractions of a dollar. Bids on lump sum items shall be item totals only; if any unit price for a lump sum item is included in a bid and it differs from the item total, the items total shall prevail.

The foregoing provisions for the resolution of specific irregularities cannot be so comprehensive as to cover every omission, inconsistency, error or other irregularity which may occur in a bid. Any situation not specifically provided for will be determined in the discretion of the County of Humboldt, and that discretion will be exercised in the manner deemed by the County of Humboldt to best protect the public interest in the prompt and economical completion of the work. The decision of the County of Humboldt respecting the amount of a bid, or the existence or treatment of an irregularity in a bid, shall be final.

If this proposal shall be accepted and the undersigned shall fail to enter into the contract and furnish the 2 bonds in the sums required by the State Contract Act, with surety satisfactory to the County of Humboldt, within 8 days, not including Saturdays, Sundays and legal holidays, after the bidder has received notice from the County of Humboldt that the contract has been awarded, the County of Humboldt may, at its option, determine that the bidder has abandoned the contract, and thereupon this proposal and the acceptance thereof shall be null and void and the forfeiture of the security accompanying this proposal shall operate and the same shall be the property of the County of Humboldt.

The undersigned, as bidder, declares that the only persons or parties interested in this proposal as principals are those named herein; that this proposal is made without collusion with any other person, firm, or corporation; that he has carefully examined the location of the proposed work, the annexed proposed form of contract, and the plans therein referred to; and he proposes, and agrees if this proposal is accepted, that he will contract with the County of Humboldt, in the form of the copy of the contract annexed hereto, to provide all necessary machinery, tools, apparatus and other means of construction, and to do all the work and furnish all the materials specified in the contract, in the manner and time therein prescribed, and according to the requirements of the Engineer as therein set forth, and that he will take in full payment therefor the following prices, to wit:

BID FORM (EXHIBIT A) (PAGE 1)
WILLIAMS CREEK BRIDGE REPLACEMENT ON GRIZZLY BLUFF ROAD
PROJECT NO.: BRLS-5904(127)
CONTRACT NO.: 594209

BASE BID - WILLIAMS CREEK BRIDGE ON GRIZZLY BLUFF ROAD

Item No.	Item Code	Item Description	Unit	Quantity	Unit Price	Total
1		Temporary Stream Diversion	LS	1		
2		Temporary Detour	LS	1		
3		Install Temporary Bridge	LS	1		
4	120090	Construction Area Signs	LS	1		
5	120100	Traffic Control System	LS	1		
6	120120	Type III Barricades	EA	8		
7	129000	Temporary Railing (Type K)	LF	160		
8	130100	Job Site Management	LS	1		
9	130300	Prepare Storm Water Pollution Prevention Plan	LS	1		
10	130310	Rain Event Action Plan	EA	43		
11	130320	Storm Water Sampling And Analysis Day	EA	16		
12	130330	Storm Water Annual Report	EA	1		
13	130610	Temporary Check Dam	LF	55		
14	130640	Temporary Fiber Rolls	LF	1,550		
15	130680	Temporary Silt Fence	LF	450		
16	130710	Temporary Construction Entrance	EA	2		
17	150605	Remove Fence	LF	96		
18	150742	Remove Roadside Sign	EA	2		
19	150812	Remove Pipe	LF	125		
20	152291	Reset Gate	EA	1		
21	152370	Relocate Mailbox	EA	2		
22	152390	Relocate Roadside Sign	EA	1		
23	153103	Cold Plane Asphalt Concrete Pavement	SY	120		
24	157550	Bridge Removal	LS	1		
25	160102	Clearing & Grubbing	LS	1		
26	170101	Develop Water Supply	LS	1		
27	190101	Roadway Excavation	CY	450		
28	190185	Shoulder Backing	TON	110		
29	192003	F Structural Excavation (Bridge)	CY	504		
30	193003	F Structural Backfill (Bridge)	CY	274		
31	200001A	Willow Stakes	EA	37		
32	200001B	Red Alder Tree	EA	100		
33	200001C	Black Cottonwood Tree	EA	10		
34	208818	P 6" Welded Steel Pipe Conduit	LF	60		
35	210430	Hydroseed	SQFT	16,000		
36	260203	Class 2 Aggregate Base	CY	670		
37	390132	Hot Mix Asphalt (Type A)	TON	580		
38	394090	Place Hot Mix Asphalt (Miscellaneous Area)	SY	170		
39	490528	P Furnish Steel Piling (HP 14x89)	LF	1964		
40	490529	Drive Steel Pile (HP 14x89)	EA	26		
41	500001	P Prestressing Cast-In-Place Concrete	LS	1		
42	510051	F Structural Concrete, Bridge Footing	CY	74		
43	510053	F Structural Concrete, Bridge	CY	285		
44	519088	P Joint Seal (MR 1")	LF	80		
45	520102	P-F Bar Reinforcing Steel (Bridge)	LB	50,208		
46	520120	P-F Headed Bar Reinforcement	EA	28		
47	721013	F Rock Slope Protection (1/4 T, Method B)	CY	358		

BID FORM (EXHIBIT A) (PAGE 2)
WILLIAMS CREEK BRIDGE REPLACEMENT ON GRIZZLY BLUFF ROAD
PROJECT NO.: BRLS-5904(127)
CONTRACT NO.: 594209

Item No.	Item Code		Item Description	Unit	Quantity	Unit Price	Total
48	720119	F	Rock Slope Protection (1 T, Method B)	CY	8		
49	721028	F	Rock Slope Protection (No.2, Method B)	CY	119		
50	729011	P	Rock Slope Protection Fabric (Class 8)	SQYD	363		
51	750501	P-F	Miscellaneous Metal (Bridge)	LB	305		
52	800003		Fence (Type BW)	LF	95		
53	800101A		Temporary Fence (Type BW)(Left in Place)	LF	280		
54	810116		Survey Monument (Type D)	EA	4		
55	820130		Object Marker	EA	4		
56	839301		Single Thrie Beam Barrier	LF	70		
57	839543		Transition Railing (Type WB-31)	LF	2		
58	839572		Return Cap (Type TA)	EA	2		
59	839585		Alternative Flared Terminal System	EA	2		
60	839738	P-F	Concrete Barrier (Type 80)	LF	186		
61	840501		Thermoplastic Traffic Stripe	LF	1,200		
62	840515		Thermoplastic Pavement Marking	SQFT	20		
63	860772	F	Communication Conduit (Bridge)	LF	114		
64	999990		Mobilization	LS	1		

Total Base Bid

ACKNOWLEDGEMENT OF ADDENDA

<u>ADDENDUM NO.</u>	<u>INITIAL</u>
_____	_____
_____	_____
_____	_____

(Bidder's Signature)

(Title)

PROPOSAL SIGNATURE PAGE

Accompanying this proposal is _____

*(NOTICE: INSERT THE WORDS "CASH (\$___)", "CASHIER'S CHECK",
"CERTIFIED CHECK", OR "BIDDERS'S BOND", AS THE CASE MAY BE.)*

in the amount of at least **TEN PERCENT (10%)** of the total bid.

The names of all persons interested in the foregoing proposal as Principals are as follows:

(NOTE: If a Bidder or other interested person is a Corporation, state the legal name of the corporation, also names of the president, secretary, treasurer, and manager thereof; if a Co-partnership, state the true name of the firm, also state the names of all individual copartners composing the firm; if the Bidder or other interested person is an Individual, state the first and last names in full.)

Licensed in accordance with an act providing for the registration of Contractors,

LICENSE NO. _____ **Classification(s)** _____

Note: It is optional to provide your contractors license number at this time. You are not required to provide your contractors license number until the time that the contract is to be awarded.

By my signature on this proposal I certify, under penalty of perjury under the laws of the State of California, that the foregoing questionnaire and statements of Public Contract Code Sections 10162, 10232 and 10285.1 are true and correct and that the bidder has complied with the requirements of Section 8103 of the Fair Employment and Housing Commission Regulations (Chapter 5, Title 2 of the California Administrative Code). By my signature on this proposal I further certify, under penalty of perjury under the laws of the State of California and the United States of America, that the Noncollusion Affidavit required by Title 23 United States Code, Section 112 and Public Contract Code Section 7106; and the Title 49 Code of Federal Regulations, Part 29 Debarment and Suspension Certification are true and correct.

Date: _____



Signature and Title of Bidder

Bidder's Business Address _____

Place of Residence _____

BIDDER'S BOND
COUNTY OF HUMBOLDT, DEPARTMENT OF PUBLIC WORKS
WILLIAMS CREEK BRIDGE REPLACEMENT ON GRIZZLY BLUFF ROAD
PROJECT NO.: BRLS-5904(127)
CONTRACT NO.: 594209

for which bids are to be opened on **TUESDAY, FEBRUARY 13, 2018**, at 2:00 PM, in the Office of the Clerk of the Board, Humboldt County Courthouse, in Eureka, California.

Know all men by these presents: That we _____

_____, as **PRINCIPAL**,

and _____

as **SURETY**, are held and firmly bound unto the County of Humboldt in the penal sum of **TEN PERCENT (10%) OF THE TOTAL AMOUNT OF THE BID** of the **PRINCIPAL** named above, submitted by said **PRINCIPAL** to the County of Humboldt for the work described above, for the payment of which sum is lawful money of the United States, well and truly to be made, to the Director of the Department to which said bid was submitted, we bind ourselves, our heirs, executors, administrators and successors, jointly and severally, firmly by these presents. In no case shall the liability of the **SURETY** hereunder exceed the sum of:

\$ _____

THE CONDITION OF THIS OBLIGATION IS SUCH, that whereas the **PRINCIPAL** has submitted the above mentioned bid to the County of Humboldt, as aforesaid, for the construction as specifically described above,

NOW, THEREFORE, if the aforesaid **PRINCIPAL** is awarded the contract, and within the time and manner required under the Specifications, after the prescribed forms are presented to him for signature, enters into a written contract, in the prescribed form, in accordance with the bid, and files two bonds with the Department, one to guarantee faithful performance and the other to guarantee payment for labor and materials, as required by law, then this obligation shall be null and void; otherwise, it shall be and remain in full force and virtue.

IN WITNESS WHEREOF, we have hereunto set our hands and seals on this

_____ day of _____, 20____.

_____ (seal)

_____ (seal)

PRINCIPAL

_____ (seal)

_____ (seal)

SURETY

Address: _____

Note: Signatures of those executing for **SURETY** must be properly acknowledged.

CONTRACTOR'S CERTIFICATE REGARDING WORKER'S COMPENSATION

Labor Code Section 3700.

"Every employer except the State and all political subdivisions or institutions thereof, shall secure the payment of compensation in one or more of the foregoing ways:

- A. By being insured against liability to pay compensation by one or more insurers duly authorized to write compensation insurance in this State.
- B. By securing from the Director of Industrial Relations a certificate of consent of self-insure, which may be given upon furnishing proof satisfactory to the Director of Industrial Relations of ability to self-insure and to pay any compensation that may become due to his employees."

I am aware of the provisions of Section 3700 of the Labor Code which requires every employer to be insured against liability for worker's compensation or to undertake self-insurance in accordance with the provisions of that code, and that I will comply with such provisions before commencing the performance of the work of this contract.

(In accordance with Article 5 [commencing at Section 1860], Chapter 1 , Part 7 , Division 2 , of the Labor Code, the above certificate must be signed and filed with the awarding body prior to commencing any work under this contract.)

EXHIBIT 12-B BIDDER'S LIST OF SUBCONTRACTORS (DBE AND NON-DBE) - PART I

PROJECT NO.: BRLS-5904(127) CONTRACT NO.: 594209

As of March 1, 2015 Contractors (and sub-contractors) wishing to bid on public works contracts shall be registered with the State Division of Industrial Relations and certified to bid on Public Works contracts. Please register at: <https://efiling.dir.ca.gov/PWCR/ActionServlet?action=displayPWCRRegistrationForm>
 In accordance with Title 49, Section 26.11 of the Code of Federal Regulations, and Section 4104 of the Public Contract Code of the State of California, as amended, the following information is required for each sub-contractor who will perform work amounting to more than one half of one percent (0.5%) of the Total Base Bid or \$10,000 (whichever is greater). **Photocopy this form for additional firms.**

Subcontractor Name and Location	Line Item & Description	Subcontract Amount	Percentage of Bid Item Sub- contracted	Contractor License Number	DBE (Y/N)	DBE Cert Number	Annual Gross Receipts
				DIR Reg Number			
Name:							<input type="checkbox"/> <\$1 million
City, State:							<input type="checkbox"/> <\$5 million
							<input type="checkbox"/> <\$10 million
							<input type="checkbox"/> <\$15 million
							Age of Firm: ___yrs.
Name:							<input type="checkbox"/> <\$1 million
City, State:							<input type="checkbox"/> <\$5 million
							<input type="checkbox"/> <\$10 million
							<input type="checkbox"/> <\$15 million
							Age of Firm: ___yrs.
Name:							<input type="checkbox"/> <\$1 million
City, State:							<input type="checkbox"/> <\$5 million
							<input type="checkbox"/> <\$10 million
							<input type="checkbox"/> <\$15 million
							Age of Firm: ___yrs.
Name:							<input type="checkbox"/> <\$1 million
City, State:							<input type="checkbox"/> <\$5 million
							<input type="checkbox"/> <\$10 million
							<input type="checkbox"/> <\$15 million
							Age of Firm: ___yrs.

Distribution: 1) Original-Local Agency File 2) Copy-DLAE w/ Award Package

EXHIBIT 12-B BIDDER'S LIST OF SUBCONTRACTORS (DBE AND NON-DBE) - PART II

PROJECT NO.: BRLS-5904(127) CONTRACT NO.: 594209

The bidder shall list all subcontractors who provided a quote or bid but were not selected to participate as a subcontractor on this project. This is required for compliance with Title 49, Section 26 of the Code of Federal Regulations. **Photocopy this form for additional firms.**

Subcontractor Name and Location	Line Item & Description	Subcontract Amount	Percentage of Bid Item Sub- contracted	Contractor License Number	DBE (Y/N)	DBE Cert Number	Annual Gross Receipts
				DIR Reg Number			
Name:							<input type="checkbox"/> <\$1 million
City, State:							<input type="checkbox"/> <\$5 million
							<input type="checkbox"/> <\$10 million
							<input type="checkbox"/> <\$15 million
							Age of Firm: ___yrs.
Name:							<input type="checkbox"/> <\$1 million
City, State:							<input type="checkbox"/> <\$5 million
							<input type="checkbox"/> <\$10 million
							<input type="checkbox"/> <\$15 million
							Age of Firm: ___yrs.
Name:							<input type="checkbox"/> <\$1 million
City, State:							<input type="checkbox"/> <\$5 million
							<input type="checkbox"/> <\$10 million
							<input type="checkbox"/> <\$15 million
							Age of Firm: ___yrs.
Name:							<input type="checkbox"/> <\$1 million
City, State:							<input type="checkbox"/> <\$5 million
							<input type="checkbox"/> <\$10 million
							<input type="checkbox"/> <\$15 million
							Age of Firm: ___yrs.
Name:							<input type="checkbox"/> <\$1 million
City, State:							<input type="checkbox"/> <\$5 million
							<input type="checkbox"/> <\$10 million
							<input type="checkbox"/> <\$15 million
							Age of Firm: ___yrs.

Distribution: 1) Original - Local Agency File

Exhibit 15-G Local Agency Bidder DBE Commitment (Construction Contracts)

LOCAL AGENCY: County of Humboldt LOCATION: Grizzly Bluff Road
 PROJECT DESCRIPTION: WILLIAMS CREEK BRIDGE REPLACEMENT ON GRIZZLY BLUFF ROAD
 TOTAL CONTRACT AMOUNT: \$ _____
 BID DATE: FEBRUARY 13, 2018
 BIDDER'S NAME: _____
 CONTRACT DBE GOAL: **10%**

CONTRACT ITEM NO.	ITEM OF WORK AND DESCRIPTION OR SERVICES TO BE SUBCONTRACTED OR MATERIALS TO BE PROVIDED (or contracted if the bidder is a DBE)	DBE CERT NO. AND EXPIRATION DATE	NAME OF EACH DBE (Must be certified on the date bids are opened - include DBE address and phone number)	DOLLAR AMOUNT DBE

<p>For Local Agency to Complete: Local Agency Contract Number: <u>CONTRACT NO.: 594209</u> Federal-aid Project Number: <u>PROJECT NO.: BRLS-5904(127)</u> Federal Share: <u>100%</u> Contract Award Date: _____</p>		Total Claimed DBE Participation \$ _____ _____ %
Local Agency certifies that all DBE certifications have been verified and information is complete and accurate.		_____ Signature of Bidder
_____ Print Name Local Agency Representative		_____ Date (Area Code) Tel. No.
_____ Signature		_____ Person to Contact (Please Type or Print)
_____ Date		_____ Local Agency Bidder DBE Commitment (Construction Contracts) (Rev 6/26/09)
(Area Code) Telephone Number: _____		

Distribution: (1) Copy – Fax or scan a copy to the Caltrans District Local Assistance Engineer (DLAE) within 30 days of contract execution. Failure to send a copy to the DLAE within 30 days of contract execution may result in de-obligation of funds for this project.
 (2) Copy – Include in award package to Caltrans District Local Assistance
 (3) Original – Local agency files

**INSTRUCTIONS - LOCAL AGENCY BIDDER
DBE COMMITMENT (CONSTRUCTION CONTRACTS)**

ALL BIDDERS:

PLEASE NOTE: This information may be submitted with your bid. If it is not, and you are the apparent low bidder or the second or third low bidder, it must be submitted and received as specified in the Special Provisions. Failure to submit the required DBE commitment will be grounds for finding the bid nonresponsive

The form requires specific information regarding the construction contract: Local Agency, Location, Project Description, Total Contract Amount, Bid Date, Bidder's Name, and Contract DBE Goal.

The form has a column for the Contract Item Number and Item of Work and Description or Services to be Subcontracted or Materials to be provided by DBEs. Prime contractors shall indicate all work to be performed by DBEs including, if the prime is a DBE, work performed by its own forces, if a DBE. The DBE shall provide a certification number to the Contractor and expiration date. Enter the DBE prime's and subcontractors' certification numbers. The form has a column for the Names of DBE contractors to perform the work (who must be certified on the date bids are opened and include the DBE address and phone number).

IMPORTANT: Identify all DBE firms participating in the project regardless of tier. Names of the First-Tier DBE Subcontractors and their respective item(s) of work listed should be consistent, where applicable, with the names and items of work in the "List of Subcontractors" submitted with your bid.

There is a column for the DBE participation dollar amount. Enter the Total Claimed DBE Participation dollars and percentage amount of items of work submitted with your bid pursuant to the Special Provisions. (If 100% of item is not to be performed or furnished by the DBE, describe exact portion of time to be performed or furnished by the DBE.) See Section "Disadvantaged Business Enterprise (DBE)," of the Special Provisions (construction contracts), to determine how to count the participation of DBE firms.

Exhibit 15-G must be signed and dated by the person bidding. Also list a phone number in the space provided and print the name of the person to contact.

Local agencies should complete the Local Agency Contract Award, Federal-aid Project Number, Federal Share, Contract Award Date fields and verify that all information is complete and accurate before signing and filing.

EXHIBIT 15-H DBE INFORMATION —GOOD FAITH EFFORTS

DBE Information - Good Faith Efforts

WILLIAMS CREEK BRIDGE REPLACEMENT ON GRIZZLY BLUFF ROAD

Federal-aid Project No PROJECT NO.: BRLS-5904(127)

CONTRACT NO.: 594209

Bid Opening Date: FEBRUARY 13, 2018

The County of Humboldt established a Disadvantaged Business Enterprise (DBE) goal of 10% for this project. The information provided herein shows that a good faith effort was made.

Lowest, second lowest and third lowest bidders shall submit the following information to document adequate good faith efforts. Bidders should submit the following information even if the "Local Agency Bidder DBE Commitment" form indicates that the bidder has met the DBE goal. This will protect the bidder's eligibility for award of the contract if the administering agency determines that the bidder failed to meet the goal for various reasons, e.g., a DBE firm was not certified at bid opening, or the bidder made a mathematical error.

Submission of only the "Local Agency Bidder DBE Commitment" form may not provide sufficient documentation to demonstrate that adequate good faith efforts were made.

The following items are listed in the Section entitled "Submission of DBE Commitment" of the Special Provisions:

- A. The names and dates of each publication in which a request for DBE participation for this project was placed by the bidder (please attach copies of advertisements or proofs of publication):

Publications	Dates of Advertisement
_____	_____
_____	_____
_____	_____

- B. The names and dates of written notices sent to certified DBEs soliciting bids for this project and the dates and methods used for following up initial solicitations to determine with certainty whether the DBEs were interested (please attach copies of solicitations, telephone records, fax confirmations, etc.):

Names of DBEs Solicited	Date of Initial Solicitation	Follow Up Methods and Dates
_____	_____	_____
_____	_____	_____
_____	_____	_____
_____	_____	_____
_____	_____	_____

- C. The items of work which the bidder made available to DBE firms including, where appropriate, any breaking down of the contract work items (including those items normally performed by the bidder with its own forces) into economically feasible units to facilitate DBE participation. It is the bidder's responsibility to demonstrate that sufficient work to facilitate DBE participation was made available to DBE firms.

Items of Work	Bidder Normally Performs Item (Y/N)	Breakdown of Items	Amount (\$)	Percentage Of Contract
_____	_____	_____	_____	_____
_____	_____	_____	_____	_____
_____	_____	_____	_____	_____

- D. The names, addresses and phone numbers of rejected DBE firms, the reasons for the bidder's rejection of the DBEs, the firms selected for that work (please attach copies of quotes from the firms involved), and the price difference for each DBE if the selected firm is not a DBE:

Names, addresses and phone numbers of rejected DBEs and the reasons for the bidder's rejection of the DBEs:

Names, addresses and phone numbers of firms selected for the work above:

- E. Efforts made to assist interested DBEs in obtaining bonding, lines of credit or insurance, and any technical assistance or information related to the plans, specifications and requirements for the work which was provided to DBEs:

- F. Efforts made to assist interested DBEs in obtaining necessary equipment, supplies, materials or related assistance or services, excluding supplies and equipment the DBE subcontractor purchases or leases from the prime contractor or its affiliate:

- G. The names of agencies, organizations or groups contacted to provide assistance in contacting, recruiting and using DBE firms (please attach copies of requests to agencies and any responses received, i.e., lists, Internet page download, etc.):

Name of Agency/Organization	Method/Date of Contact	Results
-----------------------------	------------------------	---------

<hr/>	<hr/>	<hr/>
<hr/>	<hr/>	<hr/>
<hr/>	<hr/>	<hr/>

- H. Any additional data to support a demonstration of good faith efforts (use additional sheets if necessary):

NOTE: USE ADDITIONAL SHEETS OF PAPER IF NECESSARY.

PUBLIC CONTRACT CODE SECTION 10285.1 STATEMENT

In conformance with Public Contract Code Section 10285.1 (Chapter 376, Stats. 1985), the bidder hereby declares under penalty of perjury under the laws of the State of California that the bidder has _____, has not _____ been convicted within the preceding three years of any offenses referred to in that section, including any charge of fraud, bribery, collusion, conspiracy, or any other act in violation of any state or Federal antitrust law in connection with the bidding upon, award of, or performance of, any public works contract, as defined in Public Contract Code Section 1101, with any public entity, as defined in Public Contract Code Section 1100, including the Regents of the University of California or the Trustees of the California State University. The term "bidder" is understood to include any partner, member, officer, director, responsible managing officer, or responsible managing employee thereof, as referred to in Section 10285.1.

Note: The bidder must place a check mark after "has" or "has not" in one of the blank spaces provided. The above Statement is part of the Proposal. Signing this Proposal on the signature portion thereof shall also constitute signature of this Statement. Bidders are cautioned that making a false certification may subject the certifier to criminal prosecution.

PUBLIC CONTRACT CODE SECTION 10162 QUESTIONNAIRE

Has the bidder, any officer of the bidder, or any employee of the bidder who has a proprietary interest in the bidder, ever been disqualified, removed, or otherwise prevented from bidding on, or completing a Federal, State or local government project because of a violation of law or a safety regulation?

YES NO

If the answer is yes, explain the circumstances in the following space.

PUBLIC CONTRACT CODE SECTION 10232 STATEMENT

In accordance with Public Contract Code Section 10232, the Contractor, hereby states under penalty of perjury, that no more than one final unappealable finding of contempt of court by a Federal court has been issued against the Contractor within the immediately preceding two year period because of the Contractor's failure to comply with an order of a Federal court which orders the Contractor to comply with an order of the National Labor Relations Board.

NOTE : The above statement and questionnaire constitute part of the Proposal, and signature on the signature portion of this Proposal shall constitute signature of this statement and questionnaire.

DEBARMENT AND SUSPENSION CERTIFICATION

TITLE 49, CODE OF FEDERAL REGULATIONS, PART 29

The bidder, under penalty of perjury, certifies that, except as noted below, he/she or any other person associated therewith in the capacity of owner, partner, director, officer, manager:

- is not currently under suspension, debarment, voluntary exclusion, or determination of ineligibility by any Federal agency;
- has not been suspended, debarred, voluntarily excluded or determined ineligible by any Federal agency within the past 3 years;
- does not have a proposed debarment pending; and
- has not been indicted, convicted, or had a civil judgement rendered against it by a court of competent jurisdiction in any matter involving fraud or official misconduct within the past 3 years.

If there are any exceptions to this certification, insert the exceptions in the following space.

Exceptions will not necessarily result in denial of award, but will be considered in determining bidder responsibility. For any exception noted above, indicate below to whom it applies, initiating agency, and dates of action.

Notes: Providing false information may result in criminal prosecution or administrative sanctions.
The above certification is part of the Proposal. Signing this Proposal on the signature portion thereof shall also constitute signature of this Certification.

(THE BIDDER'S EXECUTION ON THE SIGNATURE PORTION OF THIS PROPOSAL SHALL ALSO CONSTITUTE AN ENDORSEMENT AND EXECUTION OF THOSE CERTIFICATIONS WHICH ARE A PART OF THIS PROPOSAL)

EQUAL EMPLOYMENT OPPORTUNITY CERTIFICATION

The bidder _____, proposed subcontractor _____, hereby certifies that he has _____, has not _____, participated in a previous contract or subcontract subject to the equal opportunity clauses, as required by Executive Orders 10925, 11114, or 11246, and that, where required, he has filed with the Joint Reporting Committee, the Director of the Office of Federal Contract Compliance, a Federal Government contracting or administering agency, or the former President's Committee on Equal Employment Opportunity, all reports due under the applicable filing requirements.

Note: The above certification is required by the Equal Employment Opportunity Regulations of the Secretary of Labor (41 CFR 60-1.7(b)(1)), and must be submitted by bidders and proposed subcontractors only in connection with contracts and subcontracts which are subject to the equal opportunity clause. Contracts and subcontracts which are exempt from the equal opportunity clause are set forth in 41 CFR 60-1.5. (Generally only contracts or subcontracts of \$10,000 or under are exempt.)

Currently, Standard Form 100 (EEO-1) is the only report required by the Executive Orders or their implementing regulations.

Proposed prime contractors and subcontractors who have participated in a previous contract or subcontract subject to the Executive Orders and have not filed the required reports should note that 41 CFR 60-1.7(b)(1) prevents the award of contracts and subcontracts unless such contractor submits a report covering the delinquent period or such other period specified by the Federal Highway Administration or by the Director, Office of Federal Contract Compliance, U.S. Department of Labor.

NONCOLLUSION AFFIDAVIT
(Title 23 United States Code Section 112 and
Public Contract Code Section 7106)

To the COUNTY OF HUMBOLDT, DEPARTMENT OF PUBLIC WORKS:

In accordance with Title 23 United States Code Section 112 and Public Contract Code 7106 the bidder declares that the bid is not made in the interest of, or on behalf of any undisclosed person, partnership, company, association, organization, or corporation; that the bid is genuine and not collusive or sham; that the bidder has not directly or indirectly induced or solicited any other bidder to put in a false or sham bid, and has not directly or indirectly colluded, conspired, connived, or agreed with any bidder or anyone else to put in a sham bid, or that anyone shall refrain from bidding; that the bidder has nor in any manner, directly or indirectly, sought by agreement, communication, or conference with anyone to fix the bid price of the bidder or any other bidder, or to fix any overhead, profit, or cost element of the bid price, or of that of any other bidder, or to secure any advantage against the public body awarding the contract or anyone interested in the proposed contract; that all statements contained in the bid are true; and, further, that the bidder has not, directly or indirectly, submitted his or her bid price or any breakdown thereof, or the contents thereof, or divulged information or data relative thereto, or paid, and will not pay, any fee to any corporation, partnership, company, association, organization, bid depository, or to any member or agent thereof to effectuate a collusive or sham bid.

NOTE: The above Noncollusion Affidavit is part of the Proposal. Signing this Proposal on the signature portion thereof shall also constitute signature of this Noncollusion Affidavit.

Bidders are cautioned that making a false certification may subject the certifier to criminal prosecution.

CERTIFICATION FOR FEDERAL AID CONTRACTS (LOBBYING ACTIVITIES)

The prospective participant certifies; by signing and submitting this bid or proposal, the best of his or her knowledge and belief, that :

1. No Federal appropriated funds have been paid or will be paid, by or on behalf of the undersigned, to any person for influencing or attempting to influence an officer or employee of any Federal agency, a Member of Congress, an officer or employee of Congress, or an employee of a Member of Congress in connection with the awarding of any Federal contract, the making of any Federal grant, the making of any Federal loan, the entering into of any cooperative agreement, and the extension, continuation, renewal, amendment, or modification of any Federal contract, grant, loan, or cooperative agreement.
2. If any funds other than Federal appropriated funds have been paid or will be paid to any person for influencing or attempting to influence an officer or employee of any Federal agency, a member of Congress, an officer or employee of Congress, or an employee of a Member of Congress in connection with this Federal contract, grant, loan, or cooperative agreement, the undersigned shall complete and submit Standard Form-LLL, "Disclosure of Lobbying Activities," in accordance with its instructions.

This certification is a material representation of fact upon which reliance was placed when this transaction was made or entered into. Submission of this certification is a prerequisite for making or entering into this transaction imposed by Section 1352, Title 31, U.S. Code. Any person who fails to file the required certification shall be subject to a civil penalty of not less than \$10,000 and not more than \$100,000 for each such failure.

The prospective participant also agrees by submitting his or her bid or proposal that he or she shall require that the language of this certification be included in all lower tier subcontracts, which exceed \$100,000 and that all such subrecipients shall certify and disclose accordingly.

DISCLOSURE OF LOBBYING ACTIVITIES

Complete this form to disclose lobbying activities pursuant to 31 U.S.C. 1352

1. Type of Federal Action <input type="checkbox"/> a. contract <input type="checkbox"/> b. grant <input type="checkbox"/> c. cooperative agreement <input type="checkbox"/> d. loan <input type="checkbox"/> e. loan guarantee <input type="checkbox"/> f. loan insurance	2. Status of Federal Action: <input type="checkbox"/> a. Bid/offer/application <input type="checkbox"/> b. Initial award <input type="checkbox"/> c. Post award	3. Report Type: <input type="checkbox"/> a. initial <input type="checkbox"/> b. material change For Material Change Only: Year _____ Quarter _____ Date of Last report _____		
4. Name and Address of Reporting Entity: Prime _____ Subawardee _____ Tier _____, <i>if known</i>		5. If Reporting Entity in No. 4 is Subawardee, Enter Name and Address of Prime: 		
6. Federal Department/Agency: 		7. Federal Program Name/Description: 		
8. Federal Action Number, if known	9. Award Amount, if known:	CFDA Number, if applicable		
10. a. Name and Address of Lobbying Entity <i>(if individual, last name, first name, MI):</i>		b. Individuals Performing Services <i>(including address if different from No. 10a)</i> <i>(last name, first name, MI):</i>		
<i>(attach continuation sheet(s) if necessary)</i>				
11. Amount of Payment (check all that apply): \$ _____ actual _____ planned	13. Type of Payment (check all that apply) <input type="checkbox"/> a. retainer <input type="checkbox"/> b. one-time fee <input type="checkbox"/> c. commission <input type="checkbox"/> d. contingent fee <input type="checkbox"/> e. deferred <input type="checkbox"/> f. other, specify: _____			
12. Form of Payment (check all that apply): <input type="checkbox"/> a. cash <input type="checkbox"/> b. in-kind; specify: nature _____ value _____				
14. Brief Description of Services Performed or to be performed and Date(s) of Service, including officer(s), employee(s), or members(s) contacted, for Payment Indicated in Item 11: 				
<i>(attach continuation sheet(s) if necessary)</i>				
15. Continuation Sheet(s) attached: <table style="width: 100%; border: none;"> <tr> <td style="text-align: center; width: 50%;">Yes</td> <td style="text-align: center; width: 50%;">No</td> </tr> </table>			Yes	No
Yes	No			
16. Information requested through this form is authorized by Title 31 U.S.C. Section 1352. This disclosure of lobbying reliance was placed by the tier above when his transaction was made or entered into. This disclosure is required pursuant to 31 U.S.C. 1352. This information will be reported to Congress semiannually and will be available for public inspection. Any person who fails to file the required disclosure shall be subject to a civil penalty of not less than \$10,000 and not more than \$100,000 for each such failure.	Signature: _____ Print Name: _____ Title: _____ Telephone Number: _____ Date: _____			
Federal Use Only:		Authorized for Local Reproduction Standard Form - LLL Standard Form LLL Rev. 09-12-97		

INSTRUCTIONS FOR COMPLETION OF SF-LLL, DISCLOSURE OF LOBBYING ACTIVITIES

This disclosure form shall be completed by the reporting entity, whether subawardee or prime Federal recipient, at the initiation or receipt of covered Federal action or a material change to previous filing pursuant to title 31 U.S.C. section 1352. The filing of a form is required for such payment or agreement to make payment to lobbying entity for influencing or attempting to influence an officer or employee of any agency, a Member of Congress an officer or employee of Congress or an employee of a Member of Congress in connection with a covered Federal action. Attach a continuation sheet for additional information if the space on the form is inadequate. Complete all items that apply for both the initial filing and material change report. Refer to the implementing guidance published by the Office of Management and Budget for additional information.

1. Identify the type of covered Federal action for which lobbying activity is and/or has been secured to influence, the outcome of a covered Federal action.
2. Identify the status of the covered Federal action.
3. Identify the appropriate classification of this report. If this is a follow-up report caused by a material change to the information previously reported, enter the year and quarter in which the change occurred. Enter the date of the last, previously submitted report by this reporting entity for this covered Federal action.
4. Enter the full name, address, city, state and zip code of the reporting entity. Include Congressional District if known. Check the appropriate classification of the reporting entity that designates if it is or expects to be a prime or subaward recipient. Identify the tier of the subawardee, e.g., the first subawardee of the prime is the first tier. Subawards include but are not limited to subcontracts, subgrants and contract awards under grants.
5. If the organization filing the report in Item 4 checks "Subawardee" then enter the full name, address, city, state and zip code of the prime Federal recipient. Include Congressional District, if known.
6. Enter the name of the Federal agency making the award or loan commitment. Include at least one organization level below agency name, if known. For example, Department of Transportation, United States Coast Guard.
7. Enter the Federal program name or description for the covered Federal action (item 1). If known, enter the full Catalog of Federal Domestic Assistance (CFDA) number for grants, cooperative agreements, loans, and loan commitments.
8. Enter the most appropriate Federal identifying number available for the Federal action identification in item 1 (e.g., Request for Proposal (RFP) number, Invitation for Bid (IFB) number, grant announcement number, the contract grant, or loan award number, the application/proposal control number assigned by the Federal agency). Include prefixes, e.g., "RFP-DE-90-001."
9. For a covered Federal action where there has been an award or loan commitment by the Federal agency, enter the Federal amount of the award/loan commitments for the prime entity identified in item 4 or 5.
10. (a) Enter the full name, address, city, state and zip code of the lobbying entity engaged by the reporting entity identified in item 4 to influenced the covered Federal action.
(b) Enter the full names of the individual(s) performing services and include full address if different from 10 (a). Enter Last Name, First Name and Middle Initial (MI).
11. Enter the amount of compensation paid or reasonably expected to be paid by the reporting entity (item 4) to the lobbying entity (item 10). Indicate whether the payment has been made (actual) or will be made (planned). Check all boxes that apply. If this is a material change report, enter the cumulative amount of payment made or planned to be made.
12. Check the appropriate box(es). Check all boxes that apply. If payment is made through an in-kind contribution, specify the nature and value of the in-kind payment.
13. Check the appropriate box(es). Check all boxes that apply. If other, specify nature.
14. Provide a specific and detailed description of the services that the lobbyist has performed or will be expected to perform and the date(s) of any services rendered. Include all preparatory and related activity not just time spent in actual contact with Federal officials. Identify the Federal officer(s) or employee(s) contacted or the officer(s) employee(s) or Member(s) of Congress that were contacted.
15. Check whether or not a continuation sheet(s) is attached.
16. The certifying official shall sign and date the form, print his/her name title and telephone number.

Public reporting burden for this collection of information is estimated to average 30 minutes per response, including time for reviewing instruction, searching existing data sources, gathering and maintaining the data needed, and completing and reviewing the collection of information. Send comments regarding the burden estimate or any other aspect of this collection of information, including suggestions for reducing this burden, to the Office of Management and Budget, Paperwork Reduction Project (0348-0046), Washington, D.C. 20503.

SF-LLL-Instructions Rev. 06-04-90«ENDIF»

Final Report – Utilization of Disadvantaged Business Enterprises

STATE OF CALIFORNIA - DEPARTMENT OF TRANSPORTATION

FINAL REPORT - UTILIZATION OF DISADVANTAGED BUSINESS ENTERPRISES (DBE), FIRST-TIER SUBCONTRACTORS

ADA Notice

For individuals with sensory disabilities, this document is available in alternate formats. For information call (916) 654-6410 or TDD (916) 654-3880 or write Records and Forms Management, 1120 N Street, MS-89, Sacramento, CA 95814.

CEM-2402F (REV 02/2008)

CONTRACT NUMBER		COUNTY	ROUTE	POST MILES	FEDERAL AID PROJECT NO.	ADMINISTERING AGENCY				CONTRACT COMPLETION DATE	
PRIME CONTRACTOR				BUSINESS ADDRESS						ESTIMATED CONTRACT AMOUNT	
										\$	
CONTRACT ITEM No.	DESCRIPTION OF WORK PERFORMED AND MATERIAL PROVIDED	COMPANY NAME AND BUSINESS ADDRESS	DBE CERT. NUMBER	CONTRACT PAYMENTS						FEDERAL SHARE \$	
				NON-DBE	DBE	BA UDBE	APA UDBE	NA UDBE	W UDBE	DATE WORK COMPLETE	DATE OF FINAL PAYMENT
			TOTAL	\$	\$	\$	\$	\$	\$	BA - Black American APA - Asian Pacific Islander NA - Native American W - Women	
\$											
UDBE											
List all First Tier Subcontractors, Disadvantaged Business Enterprises (DBEs) and underutilized DBEs (UDBEs) regardless of tier, whether or not the firms were originally listed for goal credit. If actual UDBE utilization (or item of work) was different th											
I CERTIFY THAT THE ABOVE INFORMATION IS COMPLETE AND CORRECT											
CONTRACTOR/CONSULTANT REPRESENTATIVE'S SIGNATURE						BUSINESS PHONE NUMBER				DATE	
TO THE BEST OF MY INFORMATION AND BELIEF, THE ABOVE INFORMATION IS COMPLETE AND CORRECT											
RESIDENT ENGINEERS SIGNATURE						BUSINESS PHONE NUMBER				DATE	

COPY DISTRIBUTION - Caltrans contracts:

Original - District Construction

Copy - Business Enterprise Program

Copy - Contractor

Copy - Resident Engineer

COPY DISTRIBUTION - Local Agency contracts:

Original - District Local Assistance Engineer

Copy - District Local Assistance Engineer

Copy - Local Agency file

STATE OF CALIFORNIA – DEPARTMENT OF TRANSPORTATION

EXHIBIT 17-O: DISADVANTAGED BUSINESS ENTERPRISES (DBE) CERTIFICATION STATUS CHANGE

CP-CEM-2403(F) (New. 10/99)

CONTACT NUMBER	COUNTY	ROUTE	POST MILES	ADMINISTERING AGENCY	CONTRACT COMPETION DATE
PRIME CONTRACTOR			BUSINESS ADDRESS		ESTIMATED CONTRACT AMOUNT

Prime Contractor: List all DBEs with changes in certification status (certified/decertified) while in your employ, whether or not firms were originally listed for good credit. Attach DBE certification/Decertification letter in accordance with the Special Provisions

CONTRACT ITEM NO.	SUBCONTRACT NAME AND BUSINESS ADDRESS	BUSINESS PHONE	CERTIFICATION NUMBER	AMOUNT PAID WHILE CERTIFIED	CERTIFICATION/DECERTIFICATION DATE Letter attached
				\$	
				\$	
				\$	
				\$	
				\$	
				\$	
				\$	
				\$	
				\$	
				\$	
				\$	
				\$	

Comments:

I CERTIFY THAT THE ABOVE INFORMATION IS COMPLETE AND CORRECT

CONTRACTOR REPRESENTATIVE SIGNATURE	TITLE	BUSINESS PHONE NUMBER	DATE
-------------------------------------	-------	-----------------------	------

TO THE BEST OF MY KNOWLEDGE, THE ABOVE INFORMATION IS COMPLETE AND CORRECT

RESIDENT ENGINEER	BUSINESS PHONE NUMBER	DATE
-------------------	-----------------------	------

Distribution Original copy -DLAE
Copy -1) Business Enterprise Program 2) Prime Contactor 3) Local Agency 4) Resident Engineer

AGREEMENT

This is an AGREEMENT made and entered into this _____ day
of _____, 20__, by and between the County of Humboldt, a
political subdivision of the State of California (hereinafter referred to as COUNTY)
and _____,
a corporation organized and existing under the laws of the State of California;
hereinafter referred to as "CONTRACTOR".

County and Contractor for the consideration hereinafter named agree as follows:

Section 1 - SCOPE OF WORK

Contractor shall furnish all Labor, Tools and Materials and perform all the work for the:

WILLIAMS CREEK BRIDGE REPLACEMENT ON GRIZZLY BLUFF ROAD
PROJECT NO.: BRLS-5904(127)
CONTRACT NO.: 594209

in accordance with the contract documents referred to in Section 3 of this Agreement.

Section 2 - CONTRACT PRICE

County shall pay, and Contractor shall accept Contractor's Bid Prices, as shown on EXHIBIT "A" attached hereto and made a part hereof, as full compensation for furnishing all materials and for doing all the work contemplated and embraced in this Agreement; also for all loss or damage, arising out of the work aforesaid, or from the actions of the elements, or from any unforeseen difficulties or obstructions which may arise or be encountered in the prosecution of the work until its acceptance by County, and for all risks of every description connected with the work; also for all expenses incurred by or in consequence of the suspension or discontinuance of the work and for well and faithfully completing the work, and the whole thereof, in the manner and according to the Plans and Specifications, and the requirements of the Engineer.

Section 3 - CONTRACT DOCUMENTS

The complete contract between the parties hereto shall consist of the following, hereinafter referred to as the CONTRACT DOCUMENTS:

- Notice to Contractors
- Plans and Drawings
- Bid Form
- Bidder's Bond
- Performance Bond
- Payment Bond
- This Agreement
- Special Provisions

And, as published by the Department of Transportation, State of California, except as modified by the Special Provisions:

- Standard Plans - dated 2010
- Standard Specifications - dated 2010
- Equipment Rental Rates in effect at the time the work is performed

And, as published by the California Department of Industrial Relations, and the California Business, Transportation and Housing Agency,

- General Prevailing Wage Rates
- Labor and Surcharge Rates

And any addenda to any of the above documents, all of which are on file in the office of the Director of Public Works of the County of Humboldt. Each of said CONTRACT DOCUMENTS is incorporated and made a part of this Agreement by the reference contained in this Section.

All rights and obligations of the County and the Contractor are fully set forth and described in the Contract Documents. All of the above named documents are intended to be complimentary, so that any work called for in one, and mentioned in the other is to be performed and executed the same as if mentioned in all said documents.

Section 4 - BEGINNING OF WORK

Following receipt and full execution and approval of the Contract Documents, and posting of the requisite Bonds as called for therein, the COUNTY will issue a "Notice to Proceed". Under no circumstances shall the CONTRACTOR enter upon the site of work until receipt of the "Notice to Proceed", or unless so authorized in writing by the COUNTY.

Section 5 - TIME OF COMPLETION

The work called for in this Agreement shall be commenced within fifteen (15) days of the date of execution of the contract by COUNTY and shall be fully completed within a period of 125 working days beginning on the fifteenth calendar day after the date of said approval of contract.

Section 6 - PREVAILING WAGE

Copies of the prevailing wage rates of per diem wages are on file in the Humboldt County Public Works office at 1106 Second Street, Eureka, California and are available to any interested person on request.

Section 7 - WORKERS' COMPENSATION

By my signature hereunder, as CONTRACTOR, I certify that I am aware of the provisions of Section 3700 of the Labor Code which requires every employer to be insured against liability for Workers' Compensation or to undertake self insurance in accordance with the provisions of that code, and I will comply with such provisions before commencing the performance of the work of this contract.

Section 8 - COMPLIANCE WITH LAWS

The Contractor agrees to comply with all local, state, and federal laws and regulations, including but not limited to the Americans With Disabilities Act. The Contractor further agrees to comply with any applicable federal, state or local licensing standards, any applicable accrediting standards, and any other applicable standards or criteria established locally or by the state or federal governments.

This agreement shall be governed by and construed in accordance with the laws of the State of California.

Section 9 - NOTICES

All notices shall be in writing and delivered in person or transmitted by mail. Notices required to be given to the COUNTY shall be addressed as follows:

Humboldt County Department of Public Works
1106 Second Street, Eureka, California, 95501

Notices required to be given to CONTRACTOR shall be addressed as follows:

IN WITNESS WHEREOF, The parties hereto have entered into this Agreement as of the date first above set forth.

COUNTY OF HUMBOLDT

(SEAL) BY _____
Chairman, Board of Supervisors
of the County of Humboldt,
State of California

ATTEST:

KATHY HAYES
Clerk of the Board of Supervisors
of the County of Humboldt,
State of California

BY _____
Clerk of the Board

CONTRACTOR

BY _____

TITLE _____

BY _____

TITLE _____

(Two Signatures Required For Corporation)

APPROVED AS TO FORM:

BY _____
Deputy County Counsel

INSURANCE CERTIFICATES REVIEWED
AND APPROVED:

BY _____
Risk Manager

PAYMENT BOND

KNOW ALL MEN BY THESE PRESENTS:

THAT WHEREAS, the County of Humboldt, by its order made _____, 20____, has awarded to _____ hereinafter designated as the "Principal," a contract for the work described as follows:

NOW, THEREFORE, we the Principal and _____, Surety, are held and firmly bound unto the County of Humboldt in the penal sum of _____ Dollars (\$ _____), lawful money of the United States of America for the payment of which sum well and truly to be made, we bind ourselves, our heirs, executors, administrators, successors and assigns, jointly and severally, firmly by these presents.

THE CONDITION OF THIS OBLIGATION IS SUCH that if said Principal, his or its subcontractors, heirs, executors, administrators, successors, or assigns, shall fail to pay any of the persons named in Section 3181 of the Civil Code, or amounts due under the Unemployment Insurance Code, with respect to work or labor performed by claimant, or for any amounts required to be deducted, withheld, and paid over to the Franchise Tax Board from the wages of employees of the Contractor and his subcontractors pursuant to Section 18806 of the Revenue and Taxation Code with respect to such work and labor as required by Sections 3247 et seq. of the Civil Code of California, then said Surety will pay for the same, in or to an amount not exceeding the amount hereinafter set forth, and also will pay in case suit is brought upon this bond, such reasonable attorney's fees, as shall be fixed by the court, awarded and taxed as in the above-mentioned statutes provided.

AND, the said Surety, for value received, hereby stipulates and agrees that no change, extension of time, alteration or addition to the terms of the contract or to the work to be performed thereunder or the specifications accompanying the same shall in any wise affect its obligations on this bond, and it does hereby waive notice of any such change, extension of time, alteration or addition to the terms of the contract, or to the work, or to the specifications.

IN WITNESS WHEREOF, this instrument has been duly executed by Principal and Surety above named, on the _____ day of _____, 20_____.

PRINCIPAL
BY _____

SURETY
BY _____
Attorney-in-fact

PERFORMANCE BOND

KNOW ALL MEN BY THESE PRESENTS: that

_____ (Name of Contractor)

_____ (Address of Contractor)

a _____, hereinafter called Principal, and
(Corporation , Partnership , or Individual)

_____ Name of Surety)

_____ (Address of Surety)

hereinafter called Surety, are held and firmly bound unto _____

_____ (Name of Owner)

_____ (Address of Owner)

hereinafter called Owner , in the penal sum of _____

_____ Dollars , \$ _____

in lawful money of the United States, for the Payment of which sum well and truly to be made, we bind ourselves, successors, and assigns, jointly and severally, by these presents.

THE CONDITION OF THIS OBLIGATION is such that whereas, the Principal entered into a certain contract with the OWNER, dated the _____ day of _____, 20 ____, a copy of which is hereto attached and made a part hereof for the construction of :

NOW , THEREFORE , if the Principal shall well , truly and faithfully perform its duties, all of the undertakings, covenants, terms, conditions, and agreements of said contract during the original term thereof, and any extensions thereof which may be granted by the OWNER, with or without notice to the Surety and during the one year guaranty period, and if he shall satisfy all claims and demands incurred under such contract, and shall fully indemnify and save harmless the OWNER from all costs and damages which it may suffer by reason of failure to do so, and shall reimburse and repay the OWNER all outlay and expense which the OWNER may incur in making good any default, then this obligation shall be void; otherwise to remain in full force and effect.

PROVIDED , FURTHER , that the said surety, for value received hereby stipulate and agrees that no change, extension of time, alteration or addition to the specifications accompanying the same shall in any wise affect its obligation on this BOND , and it does hereby waive notice of any such change, extension of time, alteration or addition to the terms of the contract or to the WORK or to the SPECIFICATIONS.

PROVIDED , FURTHER , that no final settlement between the OWNER and the CONTRACTOR shall abridge the right of any beneficiary hereunder, whose claim may be unsatisfied.

IN WITNESS WHEREOF, this instrument is executed in ____ counterparts, one of which shall
(number)
be deemed an original, this the _____ day of _____, 20__ .

ATTEST :

(Principal) Secretary
(SEAL)

BY _____ Principal _____ (s)

(Witness as to Principal)

Address

Address

Surety

ATTEST :

(SEAL)

(Witness as to Surety)

Address

BY _____ Attorney - in - Fact _____

Address

NOTE : Date of BOND must not be prior to date of contract. If CONTRACTOR is Partnership, all partners should execute BOND.

IMPORTANT : Surety companies executing BONDS must appear on the Treasury Department's most current list (Circular 570 as amended) and be authorized to transact business in the state where the PROJECT is located.

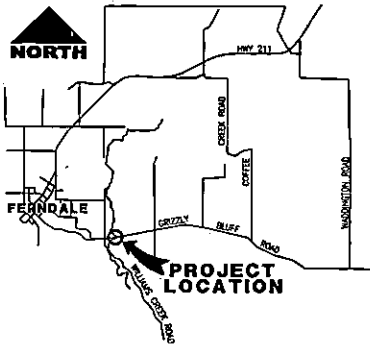

VICINITY MAP
NOT TO SCALE

INDEX OF SHEETS

- 1 TITLE SHEET
- 2 PROJECT CONTROL
- 3 TYPICAL ROAD SECTIONS
- 4-5 PLAN AND PROFILE
- 6-9 CONSTRUCTION DETAILS
- 10 DRAINAGE AND UTILITIES PLAN
- 11 DETOUR PLAN AND PROFILE
- 12 TEMPORARY STREAM DIVERSION
- 13 REVEGETATION PLAN
- 14 EROSION CONTROL PLAN AND BMPs
- 15 CONSTRUCTION AREA SIGNS
- 16 SIGNING AND STRIPING
- 17-29 BRIDGE PLANS

NOTES

THE CONTRACTOR SHALL HAVE A CLASS "A" LICENSE FOR THIS PROJECT.
STANDARD PLAN LIST APPLICABLE TO THIS CONTRACT IS INCLUDED IN THE SPECIAL PROVISIONS.

DESIGN DESIGNATION

ADT=598 (2011)
DESIGN SPEED=50 MPH

GEOTECH REPORT

APRIL 2015 & SEPTEMBER 2016 ADDENDUM
CRAWFORD & ASSOCIATES, INC.

MAP IS ONE INCH OR ORIGINAL DRAWING IF NOT ONE INCH ON THIS SHEET, ADJUST SCALES ACCORDINGLY	ROAD NAME: GRIZZLY BLUFF ROAD	MARK THOMAS & CO	COUNTY OF HUMBOLDT DEPARTMENT OF PUBLIC WORKS	SHEET 1
	ROAD NO: 20100	MILE POST: 10.51	PROJECT NO: BRLS-5904(127)	OF
	CONTRACT NO: 594209	LA NO: 65000	BRIDGE NO: 4C-258	29
	DRAWING FILE NAME:	DESIGNED BY: JO	GRIZZLY BLUFF ROAD BRIDGE REPLACEMENT	
	PLAT DATE: OCTOBER 2017	REVISION DATE: 12/31/2018	APPROVED BY: JM	TITLE SHEET

COUNTY OF HUMBOLDT DEPARTMENT OF PUBLIC WORKS PROJECT PLANS FOR CONSTRUCTION OF WILLIAMS CREEK BRIDGE (4C-258) ON GRIZZLY BLUFF ROAD (2G100) PROJECT NO. BRLS-5904(127) CONTRACT NO. 594209

TO BE SUPPLEMENTED BY STATE OF CALIFORNIA DEPARTMENT OF TRANSPORTATION
STANDARD PLANS, STANDARD SPECIFICATIONS, AND LATEST REVISED 2010 STANDARD SPECIFICATIONS

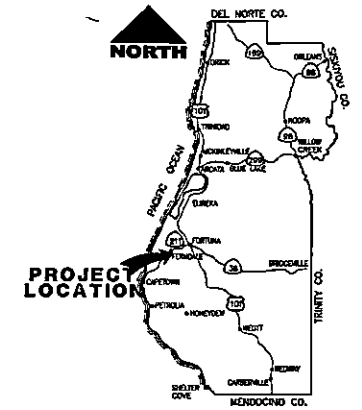

LOCATION MAP
NOT TO SCALE

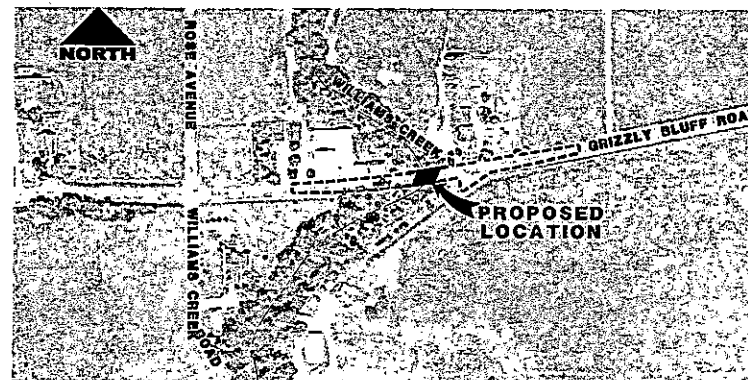

ZS
ZACHARY J. SIMILIA
RCE 73128, Exp. 12/31/2018

12/18/17
DATE



ORIGINAL LOW BID PRICE	CONSTRUCTED BY	RESIDENT ENGINEER
	PROJECT COMPLETED	CONSTRUCTION COST \$

GENERAL NOTES

1. CONTRACTOR IS RESPONSIBLE FOR PRESERVATION AND/OR PERPETUATION OF ALL EXISTING MONUMENTS WHICH CONTROL SUBDIVISIONS, TRACTS, BOUNDARIES, STREETS, HIGHWAYS, OR OTHER RIGHTS-OF-WAY, EASEMENTS, OR PROVIDE SURVEY CONTROL WHICH MAY BE DISTURBED OR REMOVED DUE TO CONTRACTORS WORK. CONTRACTOR SHALL PROVIDE A MINIMUM OF 10 WORKING DAYS NOTICE TO CIVIL ENGINEER OR SURVEYOR IN RESPONSIBLE CHARGE OF THE WORK PRIOR TO DISTURBANCE OR REMOVAL OF EXISTING MONUMENTS. CIVIL ENGINEER OR SURVEYOR IN RESPONSIBLE CHARGE OF THE WORK SHALL COORDINATE WITH CONTRACTOR TO RESET MONUMENTS OR PROVIDE PERMANENT WITNESS MONUMENTS AND FILE THE REQUIRED DOCUMENTATION WITH THE COUNTY SURVEYOR PURSUANT TO BUSINESS AND PROFESSIONS CODE SECTION 8771.

2. PROPERTY LINES SHOWN HEREIN ARE FOR INFORMATIONAL PURPOSES ONLY AND HAVE NOT BEEN VERIFIED BY SURVEY.

LEGEND

- BEGIN/END CURVE
- △ ANGLE POINT
- 290 → CONTROL POINT
- ⊙ MONUMENT TO PRESERVE OR REFERENCE/REPLACE

BASIS OF BEARING

BEARINGS SHOWN ARE BASED ON RECORD OF SURVEY BOOK 70 PAGE 84, WHICH WAS TIED TO RECORD OF SURVEY BOOK 58 PAGES 120 TO 123 (N18°07'04"W BETWEEN FOUND MONUMENTS 2 & 3).

BASIS OF ELEVATION

ELEVATION IS BASED ON NGS BM P1488 (PID LV1280) HAVING ELEVATION OF 81.97 FEET. (NGVD 29 DATUM)

RIGHT OF WAY

THAT PORTION OF GRIZZLY BLUFF ROAD LYING WITHIN 25' OF CENTERLINE AS DEDICATED TO THE COUNTY OF HUMBOLDT AS SHOWN ON 11PM37. THE REMAINDER OF THE PROJECT IS IMPLIED COMMON LAW DEDICATION OF VARIABLE WIDTH VIA LONGTIME PUBLIC USE AND MAINTENANCE BY THE COUNTY.



ROAD NAME: GRIZZLY BLUFF ROAD	DATE PLOTTED: 10/27	MARK THOMAS & CO
ROAD NO: 22130	PROJECT NO: 20130	DESIGNED BY: SD
PROJECT NO: 20130(137)	DATE: 10/20/2013	DRAWN BY: JH
CONTRACT NO: 20130	ISSUE NO: 1C-236	CHECKED BY: JH
DRAWING FILE NAME:	PLUT DATE: OCTOBER 2017	REVISION DATE: 10/20/2023
		APPROVED BY: JH

COUNTY OF HUMBOLDT DEPARTMENT OF PUBLIC WORKS	SHEET 2 OF 29
GRIZZLY BLUFF ROAD BRIDGE REPLACEMENT	
PROJECT CONTROL	

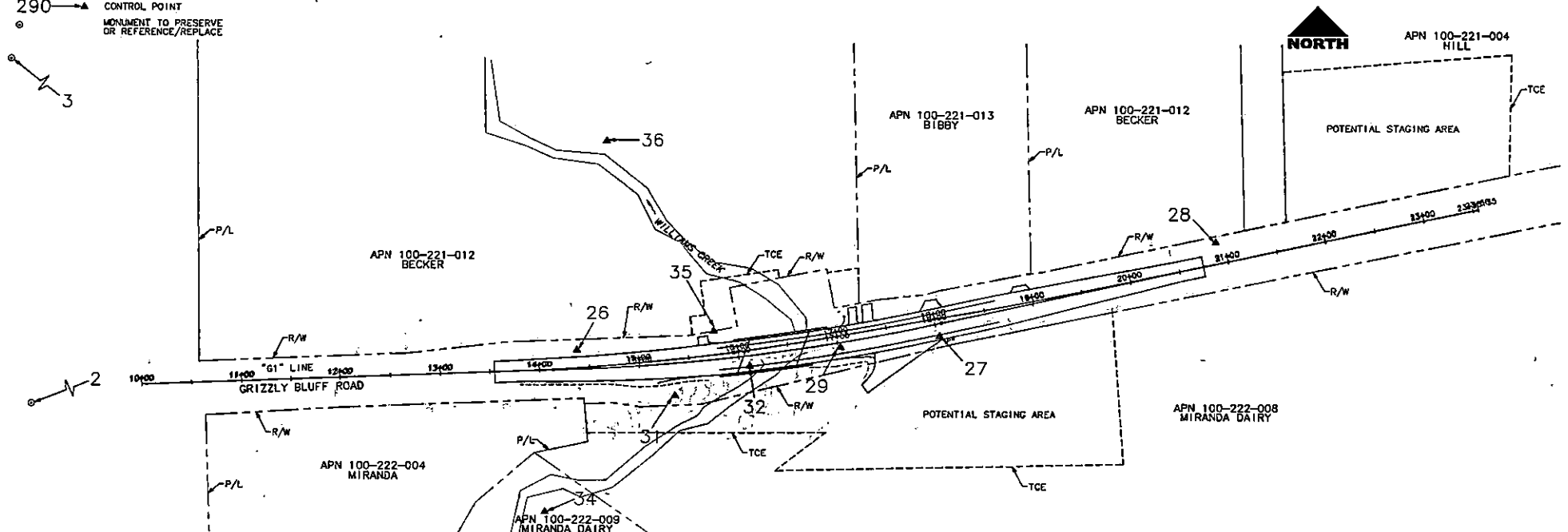

PLAN VIEW
SCALE: 1" = 50'

SURVEY CONTROL DATA					
NUMBER	APPROX. LOCATION	NORTHING	EASTING	ELEVATION	DESCRIPTION
2	NO STATIONING	10000.00	20000.00	89.50	FOUND 1/16 BRASS PIN
3	NO STATIONING	12148.58	19297.00	44.98	FOUND 2" BRASS CAP STAMPED LS3431
26	*G1* 14+38.03, 19.23' LT	10071.94	21058.47	84.15	SET 800 SPIKE
27	*G1* 18+01.78, 12.79' RT	10087.04	21422.29	80.42	SET MAG NAIL AND DPW TAG
28	*G1* 20+91.88, 21.29' LT	10182.77	21698.52	56.85	SET 800 SPIKE
29	*G1* 17+01.94, 04.82' RT	10075.73	21322.36	67.57	FOUND CONC DOME
31	*G1* 15+33.23, 32.87' RT	10026.39	21157.14	62.32	SET 800 SPIKE
32	*G1* 18+09.93, 10.50' RT	10058.84	21231.84	80.10	SET 800 SPIKE
34	*G1* 14+01.42, 142.24' RT	9908.28	21027.12	81.42	SET 800 SPIKE
35	*G1* 15+77.41, 28.68' LT	10091.79	21195.12	64.18	SET 3/8" REBAR AND HUMBOLDT CD DPW CAP
38	*G1* 14+80.11, 228.18' LT	10282.85	21087.02	59.55	SET 800 SPIKE

* COORDINATES SHOWN ARE BASED ON LOCAL SYSTEM

G1 COORDINATE TABLE		
NORTHING	EASTING	DESCRIPTION
10049.79	20976.31	13+55.00 CONFORM
10050.78	21001.29	13+80.00 AP
10051.83	21035.08	14+13.81 BC
10100.54	21424.10	18+08.44 EC
10153.23	21681.90	20+50.00 AP
10158.42	21688.35	20+75.00 CONFORM

* COORDINATES SHOWN ARE BASED ON LOCAL SYSTEM

GENERAL NOTES

1. DIMENSIONS OF THE STRUCTURAL SECTIONS ARE SUBJECT TO TOLERANCES SPECIFIED IN THE STANDARD SPECIFICATIONS.
2. STRUCTURAL SECTION RECOMMENDATIONS PER GEOTECHNICAL FOUNDATION REPORT BY CRAWFORD & ASSOCIATES, DATED APRIL 2015.
3. PAYMENT SECTION BASED ON A T1 OF B AND AN R VALUE OF 28.



ROAD NAME: GRIZZLY BLUFF ROAD	DATE: 10/21	MARK THOMAS & CO
ROAD NO: 2010	DATE: 10/21	DESIGNED BY: SD
PROJECT NO: 1812-180(17)	LA NO: 180007	DRAWN BY: JH
CONTRACT NO: 18-208	SHEET NO: 40-258	CHECKED BY: JH
DRAWING FILE NAME:	DATE: 10/21/2017	APPROVED BY: JH
PLAT DATE: DECEMBER 2017	REVISION DATE: 12/19/2018	

COUNTY OF HUMBOLDT DEPARTMENT OF PUBLIC WORKS
GRIZZLY BLUFF ROAD BRIDGE REPLACEMENT
TYPICAL ROAD SECTIONS

SHEET 3 OF 29

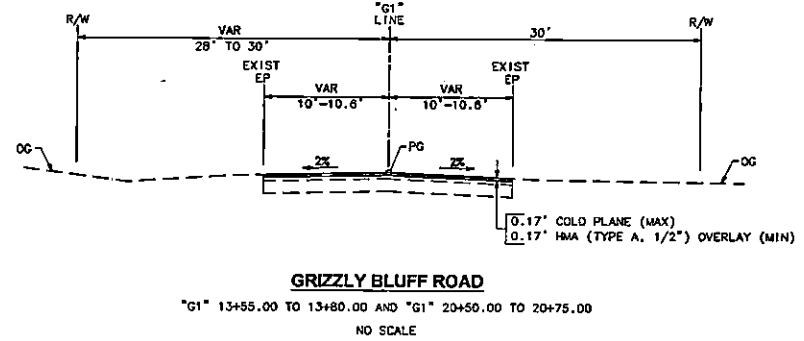
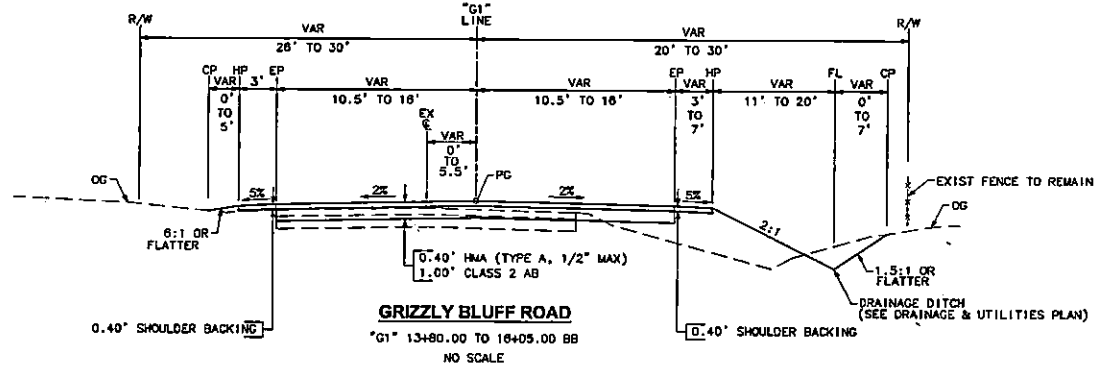
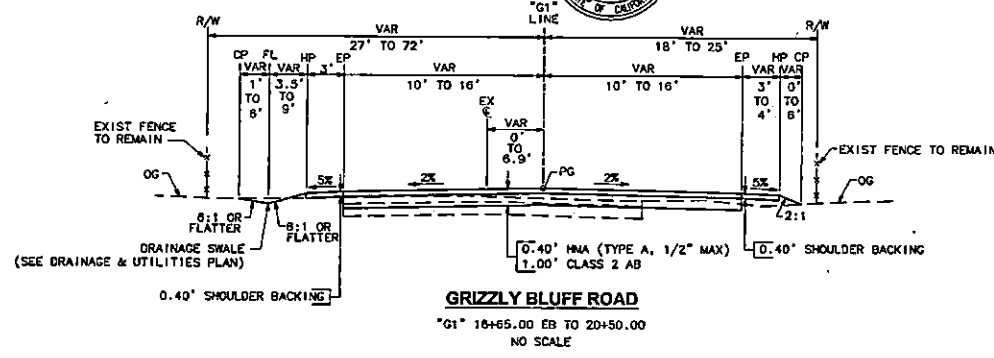

NOTES

- FOR ACCURATE RIGHT OF WAY DATA, CONTACT COUNTY OFFICE.
- SEE DRAINAGE AND UTILITIES PLAN FOR DITCH FLOW LINE, AND UTILITY INFORMATION.

CURVE DATA

No.	R	Δ	T	L
①	2100.00'	10°42'44"	185.69'	392.63'



ROAD NAME: GRIZZLY BLUFF ROAD	DATE PLOTTED: 10/31	MARK THOMAS & CO.
ROAD NO.: 3030	PROJECT NO.: 2015-2044(17)	DESIGNED BY: SD
CONTRACT NO.: 99-220	DRAWING NO.: 10-258	DRAWN BY: JH
DRAWING FILE NAME:	REVISED BY: JH	APPROVED BY: SD
PLOT DATE: OCTOBER 2017	REVISION DATE: 10/30/2024	

COUNTY OF HUMBOLDT DEPARTMENT OF PUBLIC WORKS
GRIZZLY BLUFF ROAD BRIDGE REPLACEMENT
PLAN AND PROFILE

SHEET **4**
OF
29

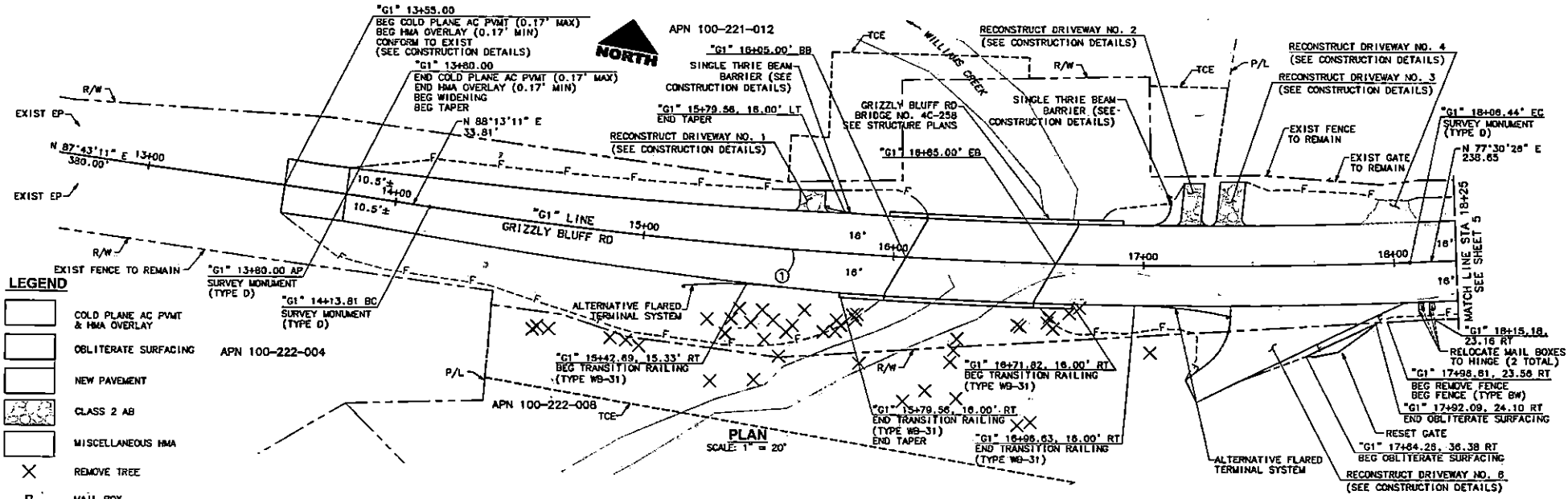

LEGEND

- COLD PLANE AC PVMT & HMA OVERLAY
- OBLITERATE SURFACING APN 100-222-004
- NEW PAVEMENT
- CLASS 2 AB
- MISCELLANEOUS HMA
- REMOVE TREE
- MAIL BOX

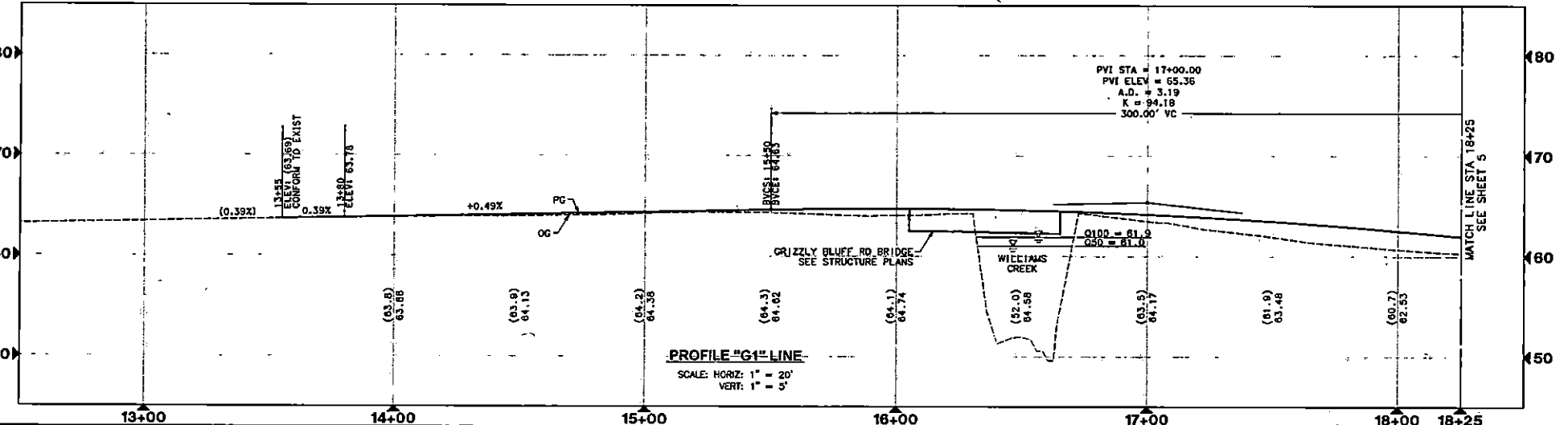



ROAD NAME: GRIZZLY BLUFF ROAD		MARK THOMAS & CO	
ROAD NO: 20250	ARC PROJ: 10.25	DESIGNED BY: 10	
PROJECT NO: 2015-2016(127)	CA NO: 202008	DRAWN BY: JM	
CONTRACT NO: 20-228	BRIDGE NO: 4C-238	REVISION BY: JM	
DRAWING FILE NAME:		APPROVED BY: 28	
POST DATE: DECEMBER 2017	REVISION DATE: 10/20/2018		

COUNTY OF HUMBOLDT DEPARTMENT OF PUBLIC WORKS	SHEET 5 OF 29
GRIZZLY BLUFF ROAD BRIDGE REPLACEMENT	
PLAN AND PROFILE	

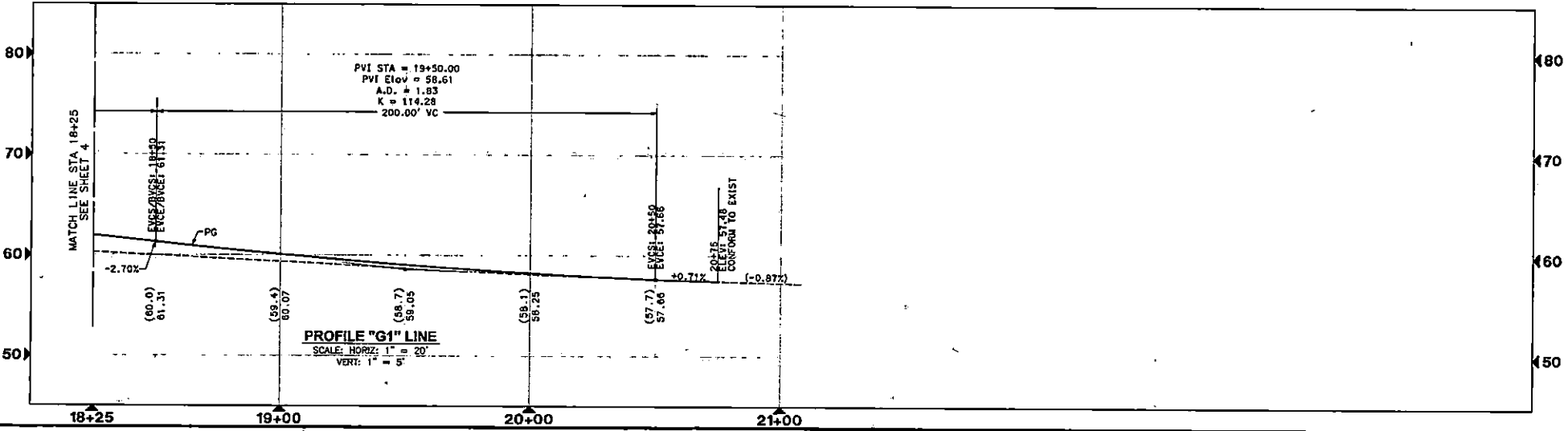
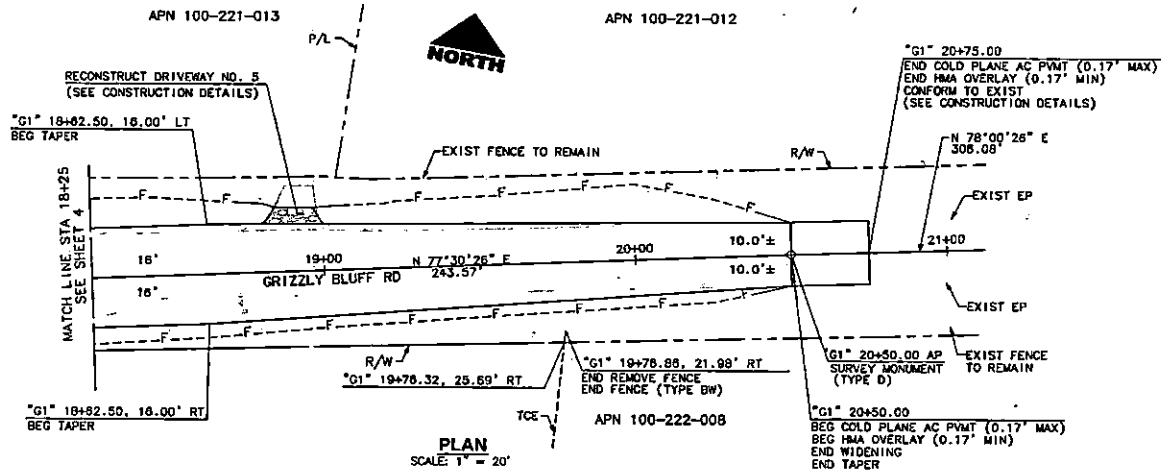

CURVE DATA

NO.	R	Δ	T	L
①	3.00'	89°51'26"	2.99'	4.70'
②	3.00'	90°24'15"	3.02'	4.73'
③	30.12'	23°18'38"	6.21'	12.25'
④	19.90'	28°D2'08"	4.97'	9.74'



ROAD NAME: GRIZZLY BLUFF ROAD	MILE POST: 15.21	MARK THOMAS & CO.
ROAD NO: 20120	EA NO: 200002	DESIGNED BY: SD
PROJECT NO: BRLS-200(127)	BRIDGE NO: 4C-258	DRAWN BY: AJB
CONTRACT NO: 584258	DRAWING FILE NAME:	REVIEWED BY: JF
POST DATE: DECEMBER 2017	REVISION DATE: 01/10/2021	APPROVED BY: JS

COUNTY OF HUMBOLDT
DEPARTMENT OF PUBLIC WORKS
GRIZZLY BLUFF ROAD BRIDGE REPLACEMENT
CONSTRUCTION DETAILS

SHEET **6**
OF
29

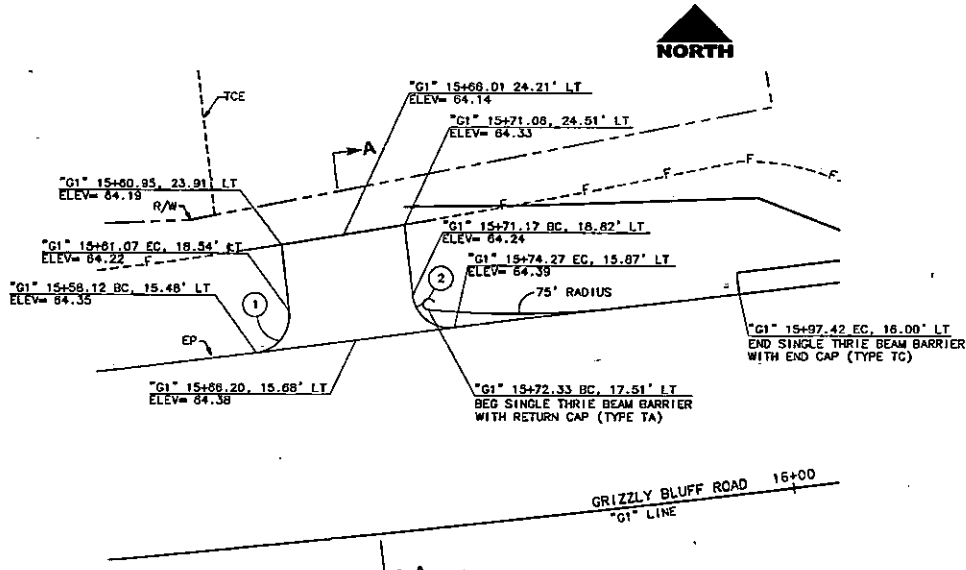

DRIVEWAY NO. 1
SCALE: 1" = 5'

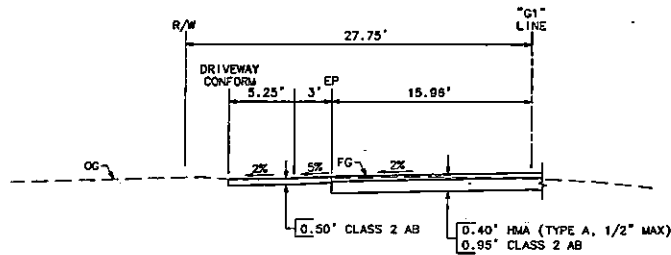

SECTION A-A
NO SCALE

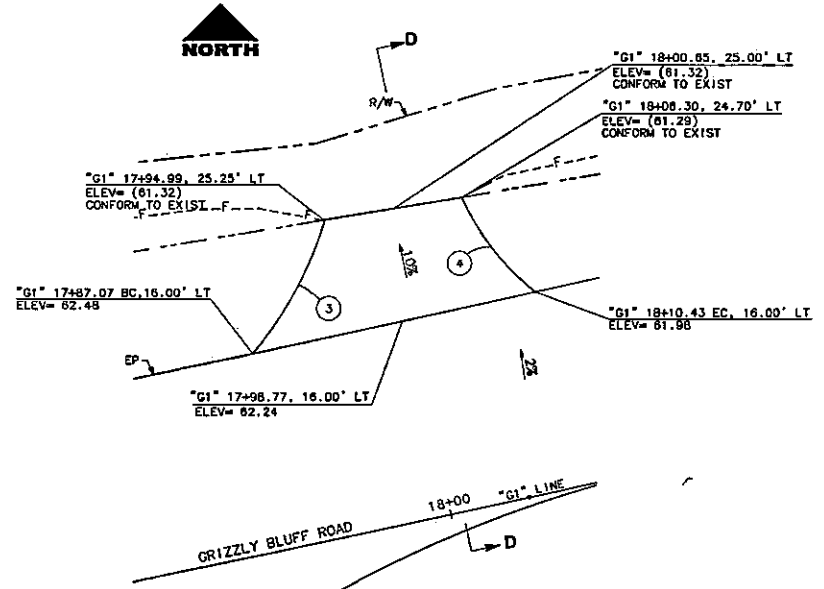

DRIVEWAY NO. 4
SCALE: 1" = 5'

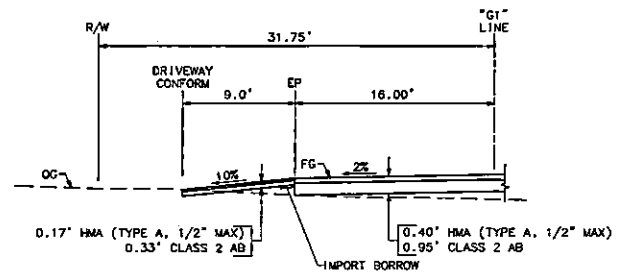

SECTION D-D
NO SCALE

CURVE DATA

No.	R	Δ	T	L
(1)	3.00'	85°13'48"	2.76'	4.48'
(2)	3.00'	180°00'00"	-	0.42'
(3)	3.00'	86°35'47"	3.37'	5.08'



ROAD NAME: GRIZZLY BLUFF ROAD	MARK THOMAS & CO.
ROAD NO.: 0000	SHEET NO.: 18/21
PROJECT NO.: 8815-2004(137)	DATE: 10/20/03
CONTRACT NO.: S8229	PROJECT NO.: 40-209
DRAWING FILE NAME:	DRAWN BY: JH
PLOT DATE: OCTOBER 2007	REVISION DATE: 12/02/2002
	APPROVED BY: JH

COUNTY OF HUMBOLDT DEPARTMENT OF PUBLIC WORKS
GRIZZLY BLUFF ROAD BRIDGE REPLACEMENT
CONSTRUCTION DETAILS

SHEET
7
OF
29

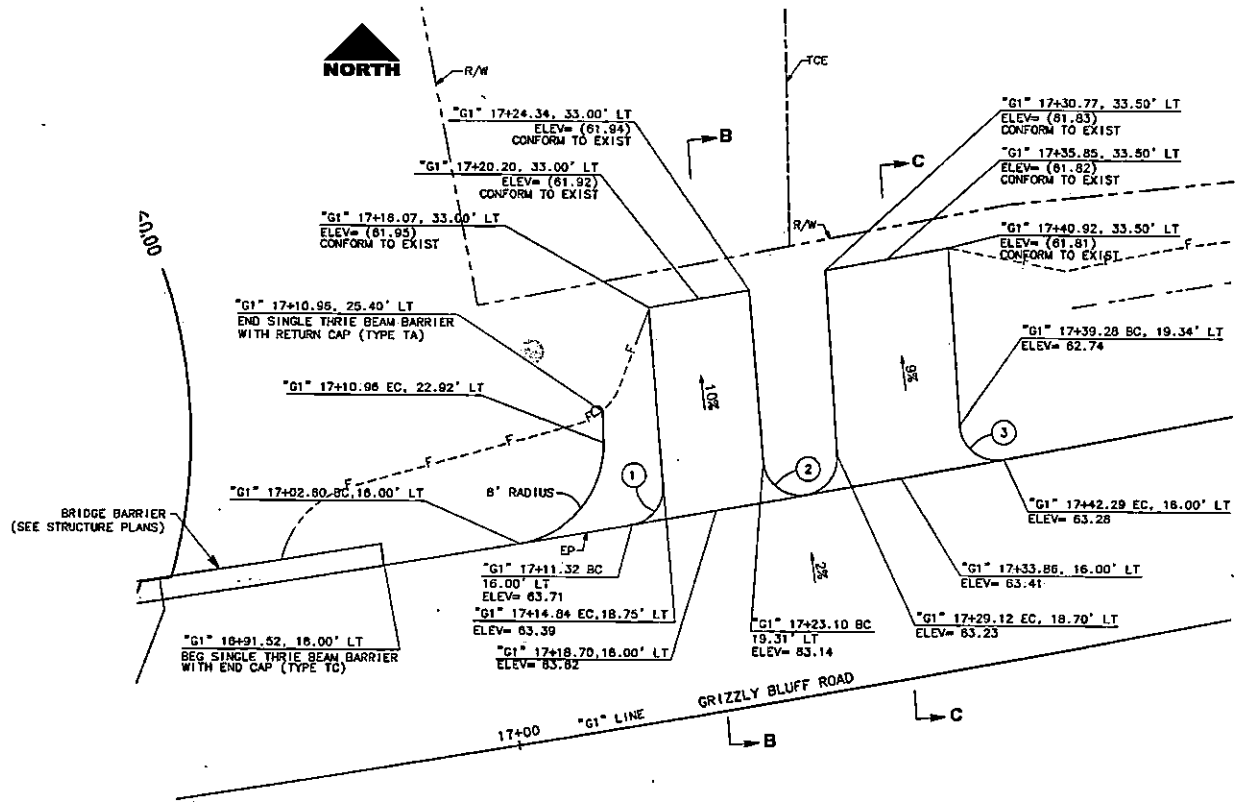

DRIVEWAY NO. 2 AND NO. 3
SCALE: 1" = 5'

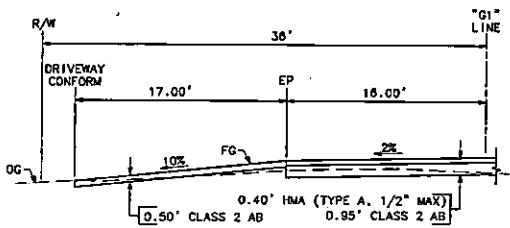

SECTION B-B
NO SCALE

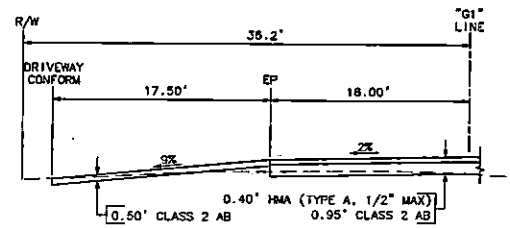

SECTION C-C
NO SCALE



ROAD NAME: GRIZZLY BLUFF ROAD
 ROAD NO: 20100
 MILE POST: 10.31
 MARK THOMAS & CO
 PROJECT NO: BRJ-360(17)
 EA NO: 00000
 DESIGNED BY: SD
 CONTRACT NO: SA-320
 BRIDGE NO: 4C-258
 DRAWN BY: JM
 DRAWING FILE NAME:
 PLOT DATE: DECEMBER 10/17
 REVISION DATE: 10/22/2021
 REVIEWED BY: JF
 APPROVED BY: ES

COUNTY OF HUMBOLDT
 DEPARTMENT OF PUBLIC WORKS
 GRIZZLY BLUFF ROAD BRIDGE REPLACEMENT

CONSTRUCTION DETAILS

SHEET
 8
 OF
 29

CURVE DATA

No.	R	Δ	T	L
(1)	20.00'	19°28'07"	3.43'	8.80'
(2)	25.00'	14°15'22"	3.13'	8.22'
(3)	25.00'	54°04'46"	12.76'	23.60'

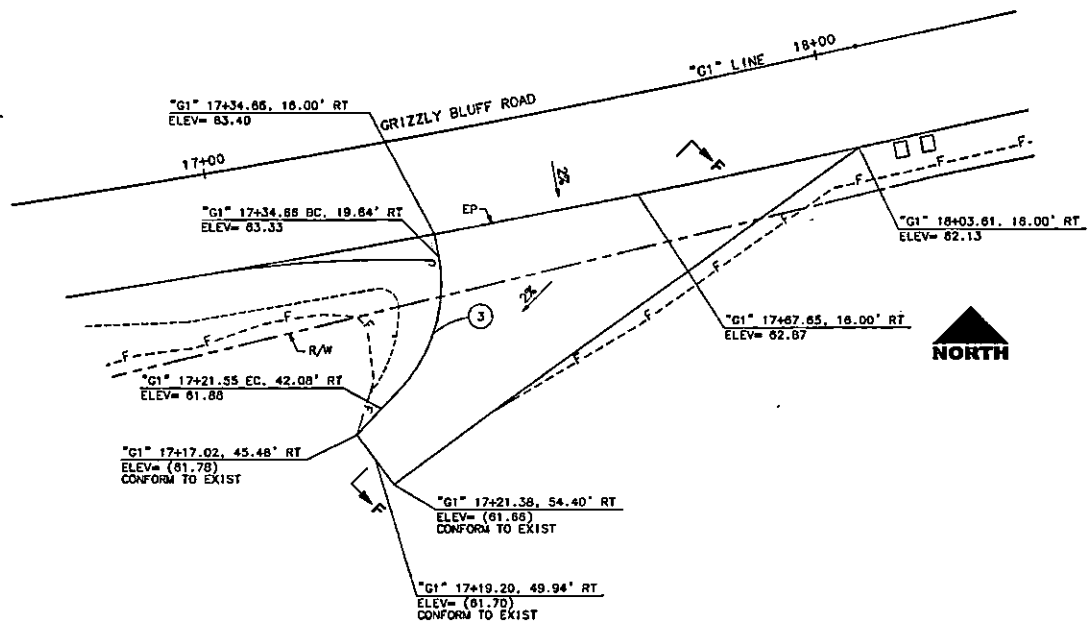
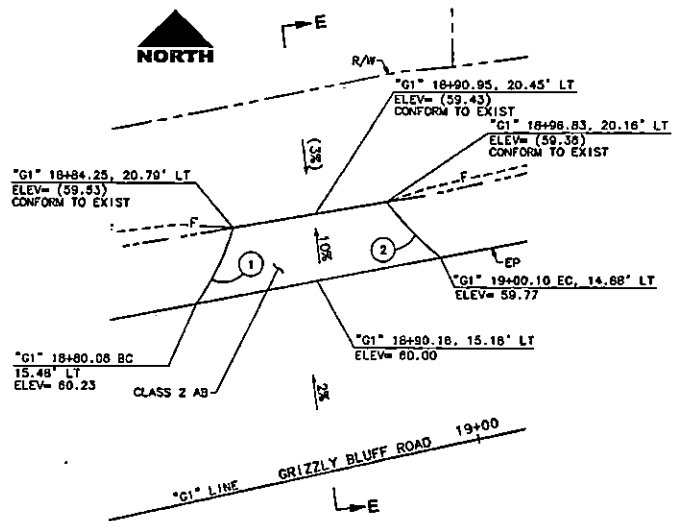

DRIVEWAY NO. 5

1"=5'

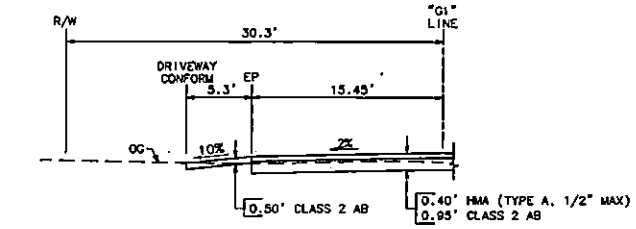

SECTION E-E
 NO SCALE

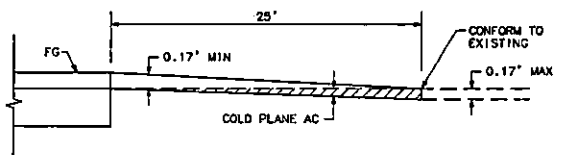

COLD PLANE AC PAVEMENT CONFORM GRIND DETAIL
 NO SCALE

DRIVEWAY NO. 6

SCALE: 1" = 10'

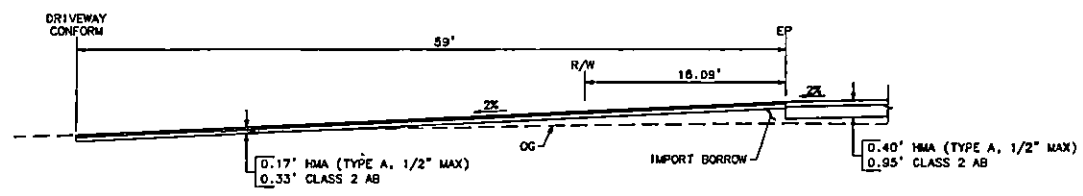

SECTION F-F
 NO SCALE



ROAD NAME: GRIZZLY BLUFF ROAD	SHEET NO.: 1521	MARK THOMAS & CO
ROAD NO.: 2210	CA HCL: 150024	DESIGNED BY: BT
PROJECT NO.: BR13-SR04(17)	BRIDGE NO.: 42-258	DRAWN BY: AH
CONTRACT NO.: SR04	DRAWING FILE NAME:	REVIEWED BY: JF
IF NOT ONE INCH ON THIS SHEET, ALWAYS SCALE ACCORDINGLY	POST DATE: DECEMBER 2017	REVISION DATE: 12/15/2008
		APPROVED BY: BT

COUNTY OF HUMBOLDT	SHEET
DEPARTMENT OF PUBLIC WORKS	9
GRIZZLY BLUFF ROAD BRIDGE REPLACEMENT	OF
CONSTRUCTION DETAILS	29

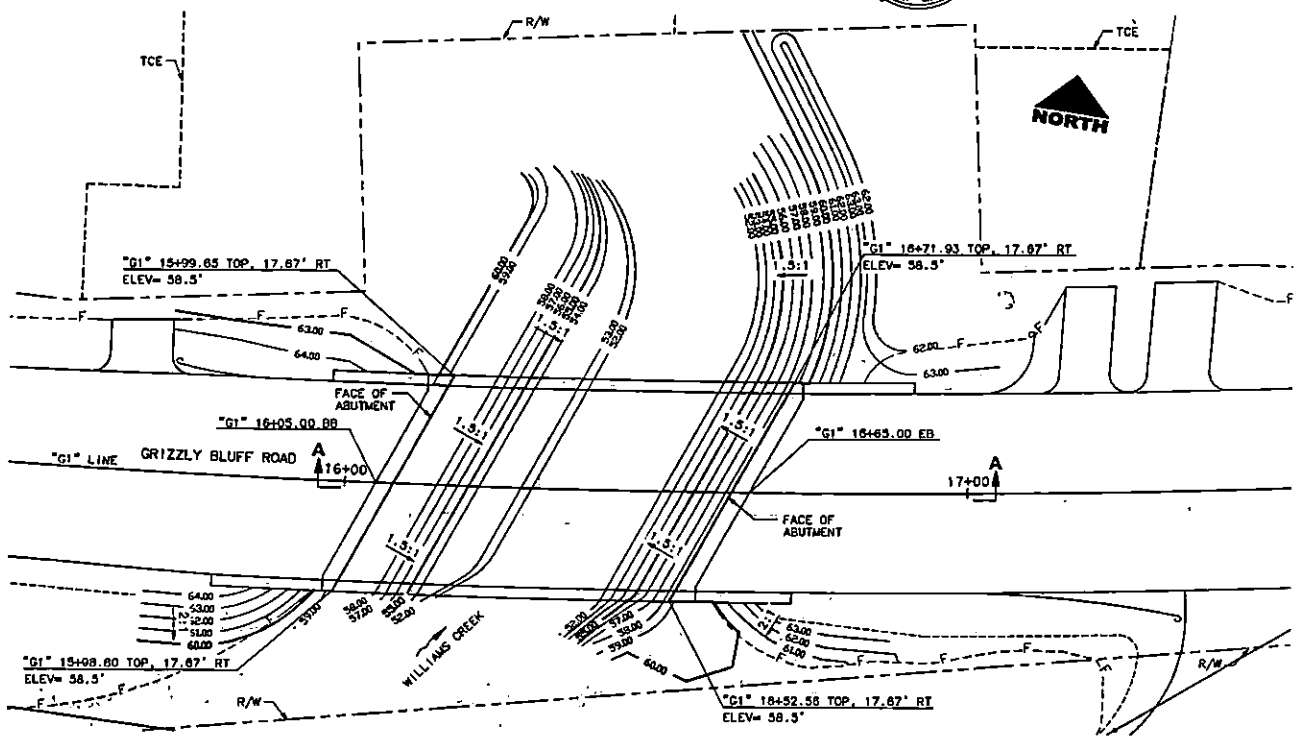

BRIDGE ABUTMENT AND GRADING DETAIL
1"=10'

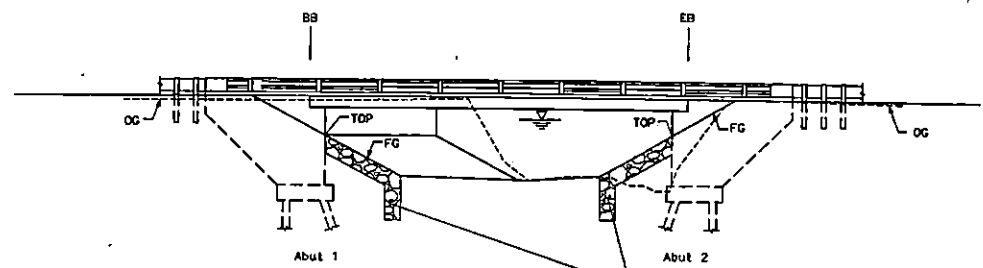

SECTION A-A
NO SCALE
SEE STRUCTURE PLANS FOR RSP LAYOUT

LEGEND

- T— EXISTING ELECTRIC (OVERHEAD) (PG&E)
- F— EXISTING TELEPHONE (UNDERGROUND) (FRONTIER COMMUNICATIONS)
- T— TELEPHONE (UNDERGROUND) (FRONTIER COMMUNICATIONS)
- IRR— EXISTING IRRIGATION (PRIVATE)
- IRR— IRRIGATION (PRIVATE)
- D— EXISTING DITCH
- D— DITCH
- A— ABANDONED WATERLINE (UNKNOWN OWNER)
- P— EXISTING POLE
- S— STEEL FLARED END SECTION



ROAD NAME: GRIZZLY BLUFF ROAD	DATE: 10/17	MARK THOMAS & CO
PROJECT NO: 2010	DATE: 10/17	DESIGNED BY: SD
PROJECT NO: 2010-2014(17)	DATE: 10/17	DRAWN BY: JM
CONTRACT NO: 2010	PROJECT NO: 10-210	REVIEWED BY: JM
DRAWING FILE NAME:	PROJECT DATE: DECEMBER 2017	REVISION DATE: 11/14/2022
PLAT DATE:	REVISION DATE:	APPROVED BY: TS

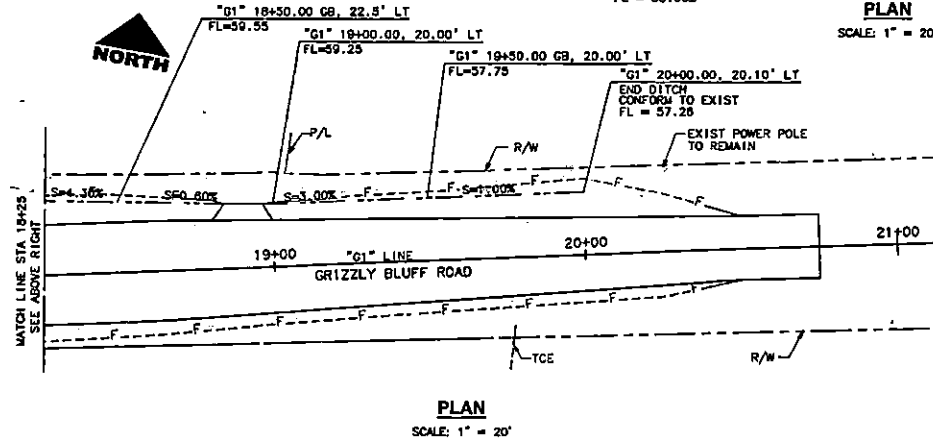
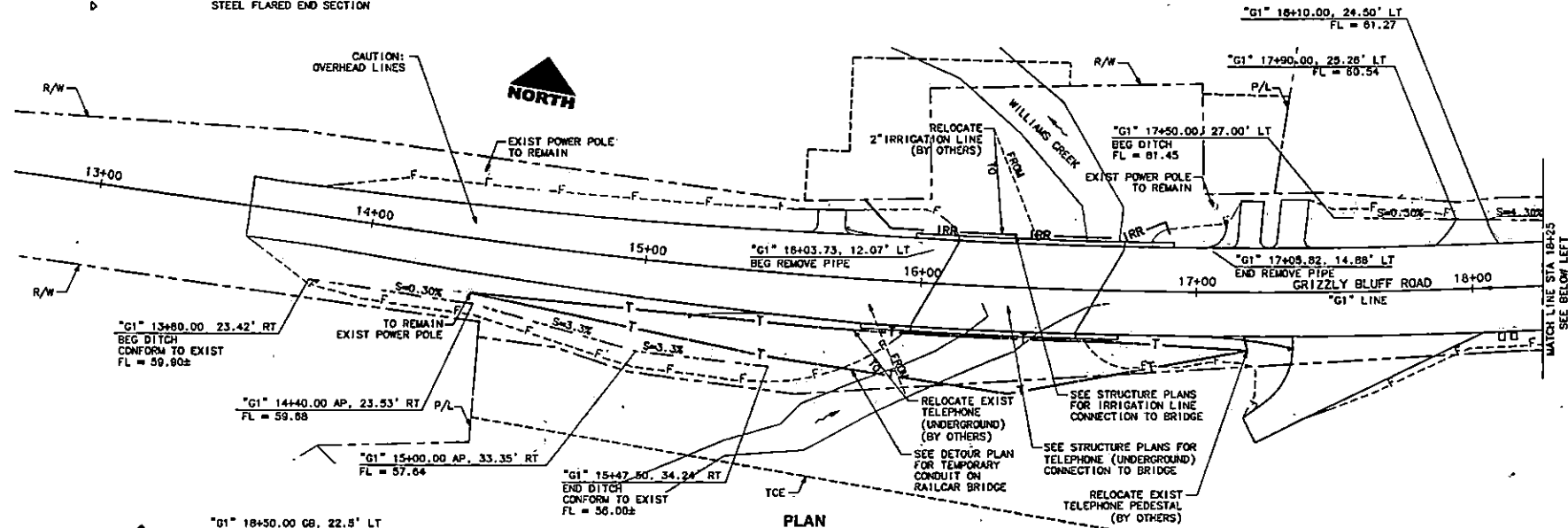

UTILITY CONTACT TABLE

AGENCY	CONTACT	ADDRESS	PHONE
FRONTIER COMMUNICATIONS	MARC GATE	PO BOX 935 COOS BAY, OR 97420	541-808-17212
PG&E	TOM DEACE	2555 MYRTLE AVE, EUREKA, CA 95501	707-445-8510

THIS PLAN ACCURATE FOR DRAINAGE AND UTILITY WORK ONLY

CURVE DATA

No.	R	Δ	T	L
①	150.00'	19°59'53"	25.45'	32.35'
②	100.00'	19°10'20"	16.89'	33.48'
③	100.00'	37°49'55"	34.27'	86.03'
④	100.00'	26°44'17"	23.77'	46.67'

NOTE:

1. CA MUTCD CODES ARE SHOWN AS DESIGNATED BY <C>A> WHICH INDICATES A CALIFORNIA SIGN CODE, OTHERWISE, FEDERAL MUTCD CODES ARE SHOWN.



PROJECT NAME: GRIZZLY BLUFF ROAD	DATE: 01/21	MARK THOMAS & CO.
ROAD NO: 2010	SHEET NO: 11	DESIGNED BY: SD
PROJECT NO: M&S-2000(27)	DATE: 12/02	DRAWN BY: JM
CONTRACT NO: 99029	BRIDGE NO: 40-258	REVIEWED BY: JF
DRAWING FILE NAME:	PROJECT DATE: OCTOBER 2017	REVISION DATE: 03/07/2020
NOT DATE:		APPROVED BY: JS

COUNTY OF HUMBOLDT
DEPARTMENT OF PUBLIC WORKS
GRIZZLY BLUFF ROAD BRIDGE REPLACEMENT
DETOUR PLAN AND PROFILE

SHEET
11
OF
29

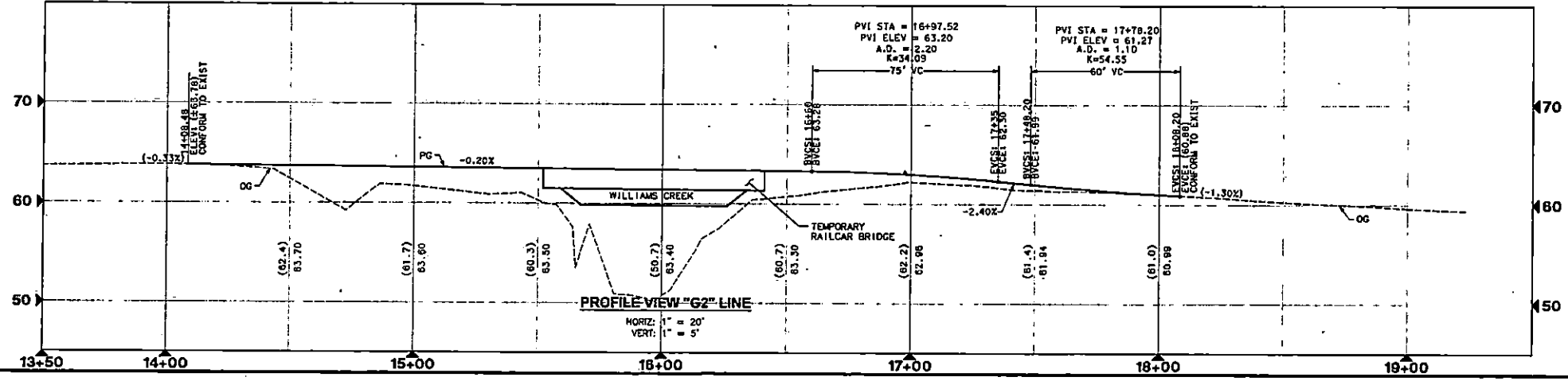
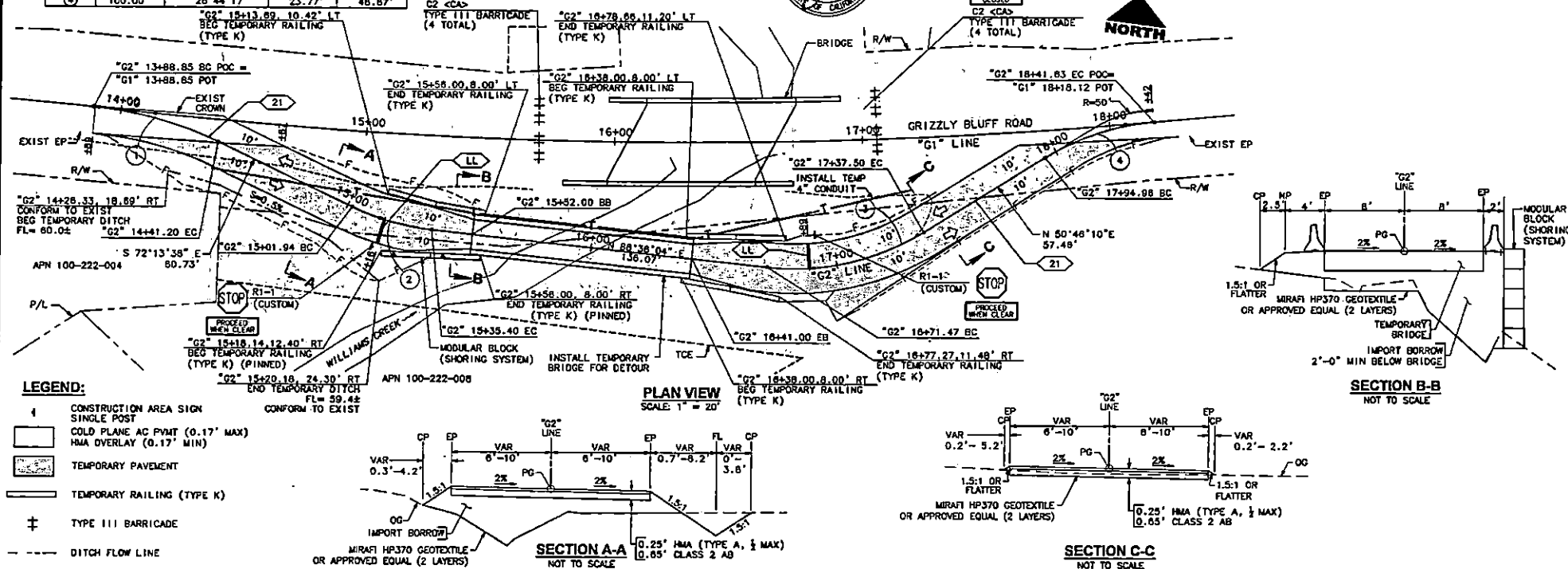

NOTES

1. SEE DETOUR PLAN AND PROFILE FOR MORE DETAILS ON TEMPORARY DETOUR ROAD.
2. PIPE DEFLECTION SHALL FOLLOW MANUFACTURER'S MAXIMUM RECOMMENDED DEFLECTION ANGLE AND OFFSET.
3. AN ALTERNATIVE DIVERSION SYSTEM CAPABLE OF HANDLING FLOWS UP TO 30 CFS WILL BE CONSIDERED WITH PRIOR APPROVAL OF THE ENGINEER.
4. FISH AND WILDLIFE PERMIT CONDITIONS MUST BE FOLLOWED WHEN DIVERTING STREAM.
5. TURBID STREAM WATER SHALL EITHER BE PUMPED UPLAND AND ALLOWED TO FILTER BACK TO STREAM AND/OR CONTRACTOR SHALL CONSTRUCT A SILT DAM AS SHOWN ON THIS SHEET.
6. 24" DIVERSION PIPE SHALL HAVE LEAK-PROOF JOINTS. THEY WILL BE BURIED OR ENCASED WITHIN 20 FEET OF THE PROPOSED BRIDGE DURING THE EXISTING BRIDGE DEMOLITION. PLASTIC PIPE SHALL BE GASKETED.
7. CONTRACTOR IS RESPONSIBLE FOR INSTALLATION AND MAINTENANCE OF FISH EXCLUSIONARY FENCE. LOCATION TO BE DETERMINED BY COUNTY.



ROAD NAME: GRIZZLY BLUFF ROAD	SHEET NO.: 12	MARK THOMAS & CO.	COUNTY OF HUMBOLDT DEPARTMENT OF PUBLIC WORKS	SHEET 12 OF 29
ROAD NO.: 20300	MILE POST: 15.21	DESIGNED BY: MD	GRIZZLY BLUFF ROAD BRIDGE REPLACEMENT	
PROJECT NO.: BLS-1504(27)	TA NO.: 100000	DRAWN BY: JM	TEMPORARY STREAM DIVERSION	
CONTRACT NO.: 28429	PROJ. NO.: 45-238	REVIEWED BY: JM		
DRAWING FILE NAME:	PROJ. DATE: DECEMBER 2017	REVISION DATE: 10/26/2018	APPROVED BY: ES	

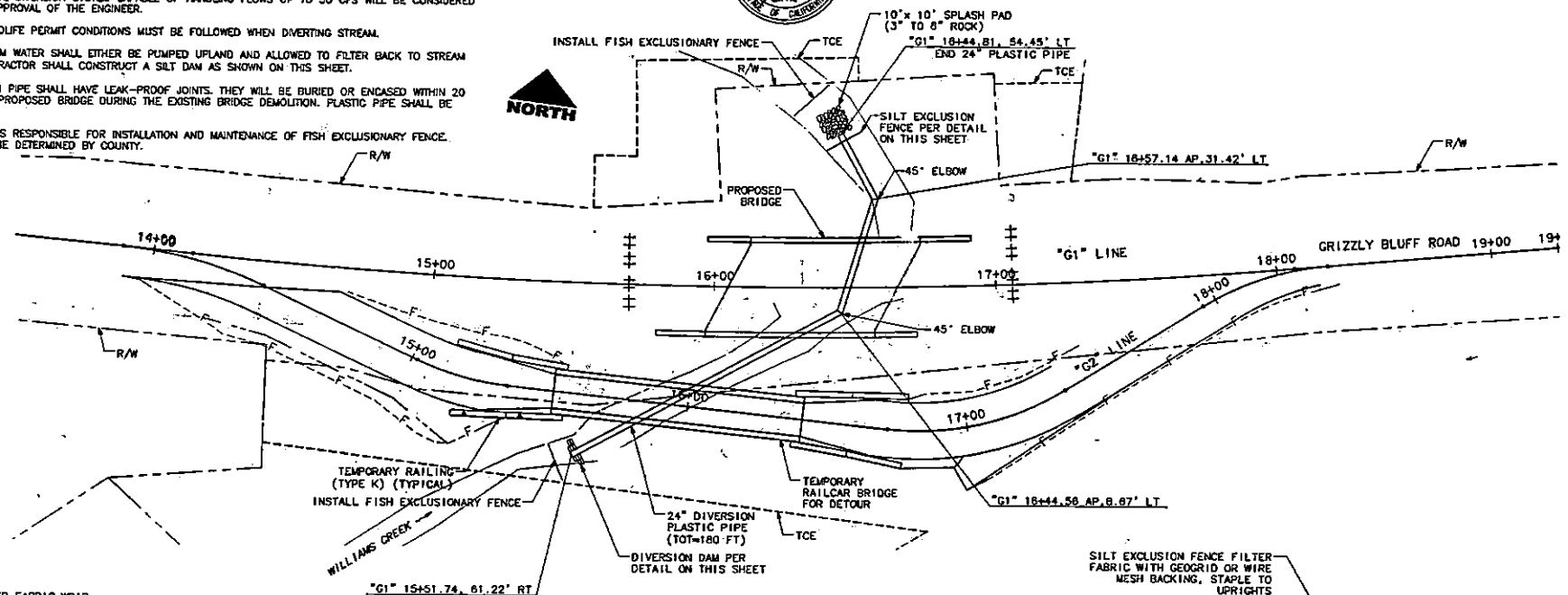

PLAN
SCALE: 1" = 20'

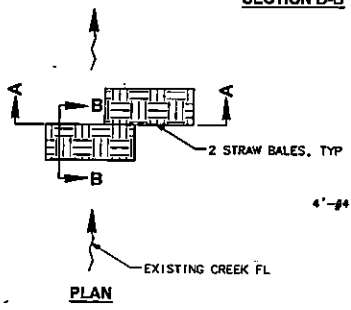
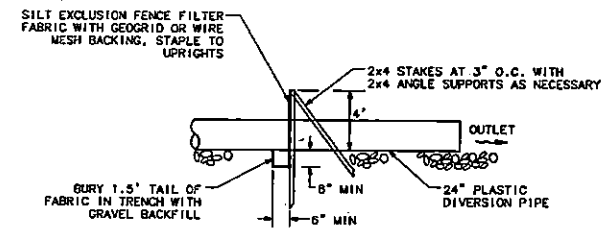
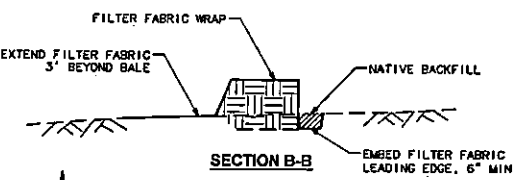

SILT DAM DETAIL
NOT TO SCALE

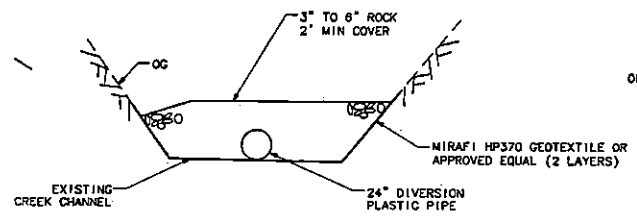
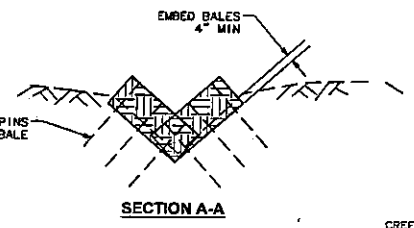

TYPICAL SECTION - DIVERSION PIPE
NOT TO SCALE

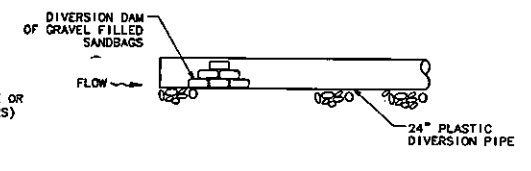

DIVERSION DAM DETAIL
NOT TO SCALE

NOTES

1. HARVEST PLANTING STAKES FROM ON-SITE OR NEARBY SOURCES.
2. SOAK STAKES FOR 5-7 DAYS PRIOR TO INSTALLATION.
3. PRE-DRIVE HOLES FOR STAKES USING AUGER OR EXCAVATOR MOUNTED STINGER. HOLE MUST EXTEND AT LEAST 6" BELOW TOP OF WATER TABLE.
4. PLACE STAKE IN PREPARED HOLE WITH 2-5 BRANCH/BUD SCARS ABOVE THE GROUND.
5. WATER PLANTING AREA THOROUGHLY AFTER INSTALLING STAKES AND ENSURE THERE ARE NO AIR POCKETS IN HOLE AROUND WILLOW STAKES.
6. PLACE 37 WILLOW STAKES 10" ON CENTER MAXIMUM. STAGGER WILLOW STAKE ROWS BY 5 FT PARALLEL TO THE ROAD.
7. REPLANT RED ALDER/ BLACK COTTONWOOD TREES AT 8 FT ON CENTER. THE TREES SHALL HAVE A MINIMUM HEIGHT OF 4 FT.



ROAD NAME: GRIZZLY BLUFF ROAD	HAZ POST: 1021	MARK THOMAS & CO
ROAD NO: 2290	CA NO: 200204	DESIGNED BY: SD
PROJECT NO: BR-1904(17)	PROJECT NO: 42-256	DRAWN BY: JH
CONTRACT NO: 9204	DRAWING FILE NAME:	REVISION BY: JH
DATE: DECEMBER 2007	REVISION DATE: 02/02/2008	APPROVED BY: DS

COUNTY OF HUMBOLDT DEPARTMENT OF PUBLIC WORKS
GRIZZLY BLUFF ROAD BRIDGE REPLACEMENT
REVEGETATION PLAN

SHEET 13
OF 29

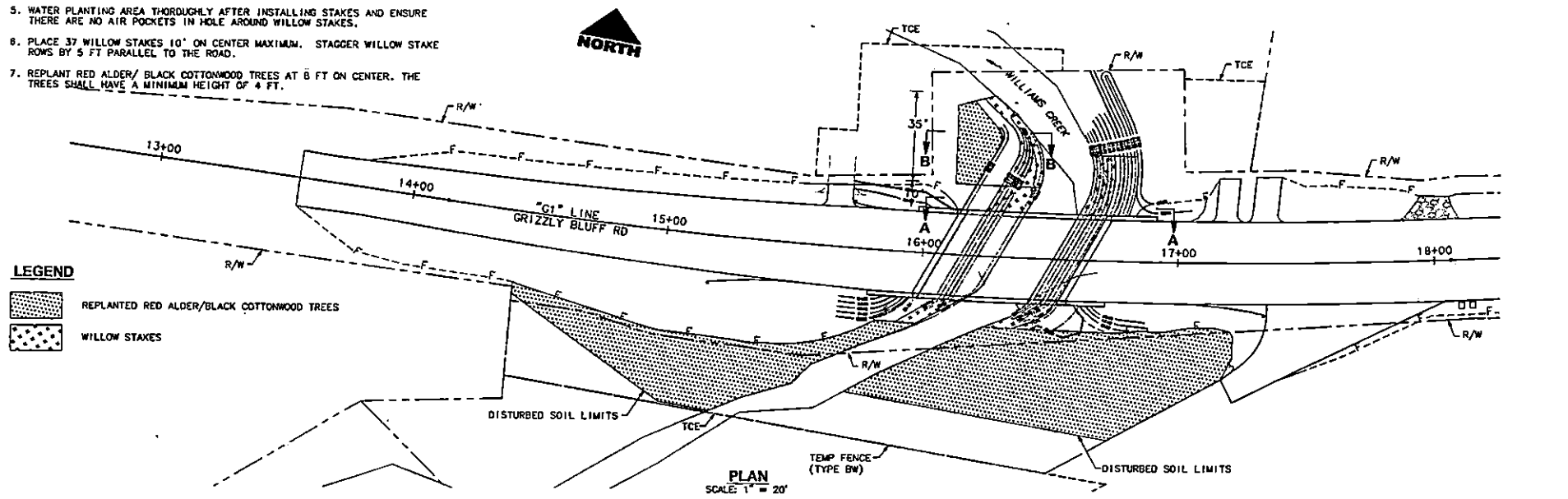

LEGEND

- REPLANTED RED ALDER/BLACK COTTONWOOD TREES
- WILLOW STAKES

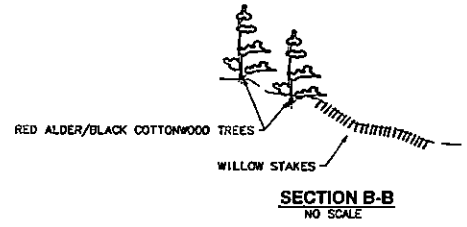
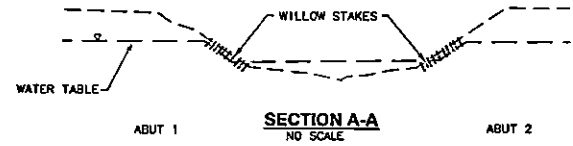
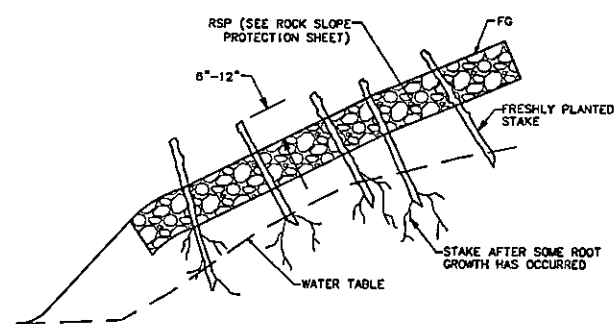
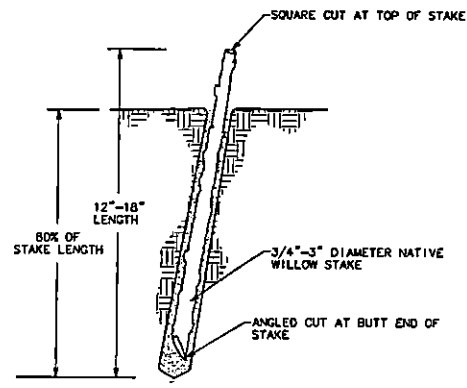

LEGEND

- TSF—xx—TSF TEMPORARY SILT FENCE
- ////TFR////TFR TEMPORARY FIBER ROLLS
- CD—CD— TEMPORARY CHECK DAM (TYPE 2)
- HYDROSEED



ROAD NAME: GRIZZLY BLUFF ROAD ROAD NO.: 2024 PROJECT NO.: BLS-1604(127) CONTRACT NO.: 84-238 DRAWING FILE NAME: PLAN DATE: OCTOBER 2017	MILE POSTS: 14.21 (LA. NO.: 100000) BRIDGE NO.: 44-238 REVISION DATE: 10/24/2018	MARK THOMAS & CO DESIGNED BY: SD CHECKED BY: JF APPROVED BY: JS	COUNTY OF HUMBOLDT DEPARTMENT OF PUBLIC WORKS GRIZZLY BLUFF ROAD BRIDGE REPLACEMENT EROSION CONTROL PLAN & BMPs	SHEET 14 OF 29
--	---	--	--	------------------------------------

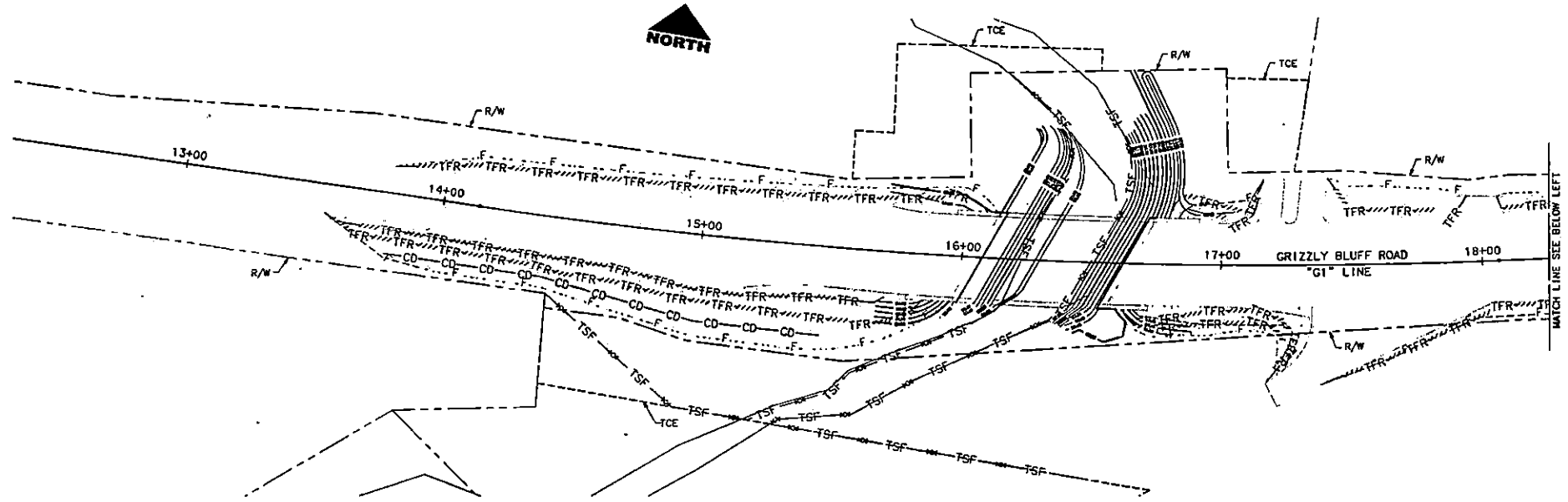

PLAN
SCALE: 1" = 20'

WATER POLLUTION CONTROL PLAN NOTES:

1. THIS WPCP WILL BE IMPLEMENTED DURING CONSTRUCTION AND ITS APPROVAL WILL BE SUBJECT TO PERMIT REQUIREMENTS AND SWPPP APPROVAL.
2. STOCKPILES SHALL BE LOCATED A MINIMUM OF 50 FEET AWAY FROM DRAINAGE COURSES. APPROPRIATE DUST AND EROSION CONTROL BMP'S SHALL BE APPLIED.
3. STAGING AREAS SHOWN ARE APPROVED BY PERMITTING AGENCIES. LAND OWNER CONSENT HAS BEEN ATTAINED THROUGH A TEMPORARY CONSTRUCTION EASEMENT (ON-FILE) FOR USING LANDS FOR STAGING AND STOCKPILING.
4. CONSTRUCTION ENTRANCES BMP'S WILL BE REQUIRED TO CONTROL VEHICLE TRACKING.
5. ALL DISTURBED SOIL AREAS SHALL BE HYDROSEEDING INCLUDING STOCKPILE/ STAGING ZONES.
6. FIBER ROLLS TO BE INSTALLED AT THE TOE OF FILL SLOPES ON ROAD SECTION.

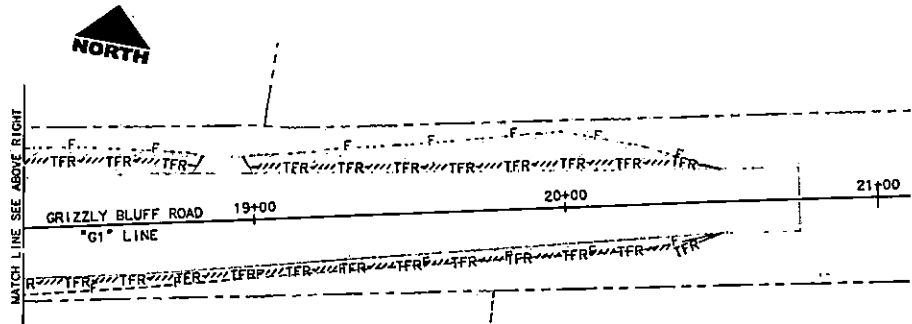

PLAN
SCALE: 1" = 20'

NOTES

1. CA MUTCD CODES SHOWN AS DESIGNATED BY <CA> WHICH INDICATES A CALIFORNIA SIGN CODE. OTHERWISE, FEDERAL MUTCD CODES ARE SHOWN.
2. SIGN LOCATIONS SHOWN ARE APPROXIMATE. EXACT LOCATIONS TO BE DETERMINED BY THE ENGINEER.
3. ALL DIMENSIONS ARE IN INCHES UNLESS OTHERWISE NOTED.



ROAD NAME: GRIZZLY BLUFF ROAD	MARK THOMAS & CO
ROAD NO: 80100	MILE POST: 10.21
PROJECT NO: WLS-3004(27)	CA NO: 200002
CONTRACT NO: 24028	BROD NO: 4C-250
DRAWING FILE NAME:	REVISION DATE: 02/20/2008
PLAT DATE: 02/20/2007	APPROVED BY: [Signature]

COUNTY OF HUMBOLDT DEPARTMENT OF PUBLIC WORKS
GRIZZLY BLUFF ROAD BRIDGE REPLACEMENT
CONSTRUCTION AREA SIGNS

SHEET
15
OF
29

CONSTRUCTION AREA SIGN SUMMARY

SIGN TYPE	QTY	DESCRIPTION	SIZE	REMARKS	POST SIZE	NUMBER OF POSTS
R1-1 (CUSTOM)	2	STOP SIGN PROCEED WHEN CLEAR	30 x 30 38 x 18	VISABLE AT ALL TIMES	4 x 6	1
W5-3 W13-1P	1	ONE LANE BRIDGE 15 MPH	36 x 36 24 x 24	VISABLE AT ALL TIMES	4 x 6	1
W5-1 C29 <CA>	2	STOP AHEAD 500 FT	36 x 36 20 x 7	VISABLE AT ALL TIMES	4 x 6	1
W20-4 W13-1P	2	ONE LANE BRIDGE AHEAD 15 MPH	36 x 36 24 x 24	VISABLE AT ALL TIMES	4 x 6	1
C23 <CA>	5	ROAD WORK AHEAD	36 x 36	VISABLE AT ALL TIMES	4 x 6	1
G20-2	2	END ROAD WORK	36 x 18	VISABLE AT ALL TIMES	4 x 4	1
C2 <CA>	2	ROAD CLOSED	48 x 30	VISABLE AT ALL TIMES	4 x 6	1
C1 <CA>	2	DETOUR AHEAD	36 x 36	VISABLE AT ALL TIMES	4 x 6	1
C7 <CA>	2	END DETOUR	24 x 18	VISABLE AT ALL TIMES	4 x 4	1

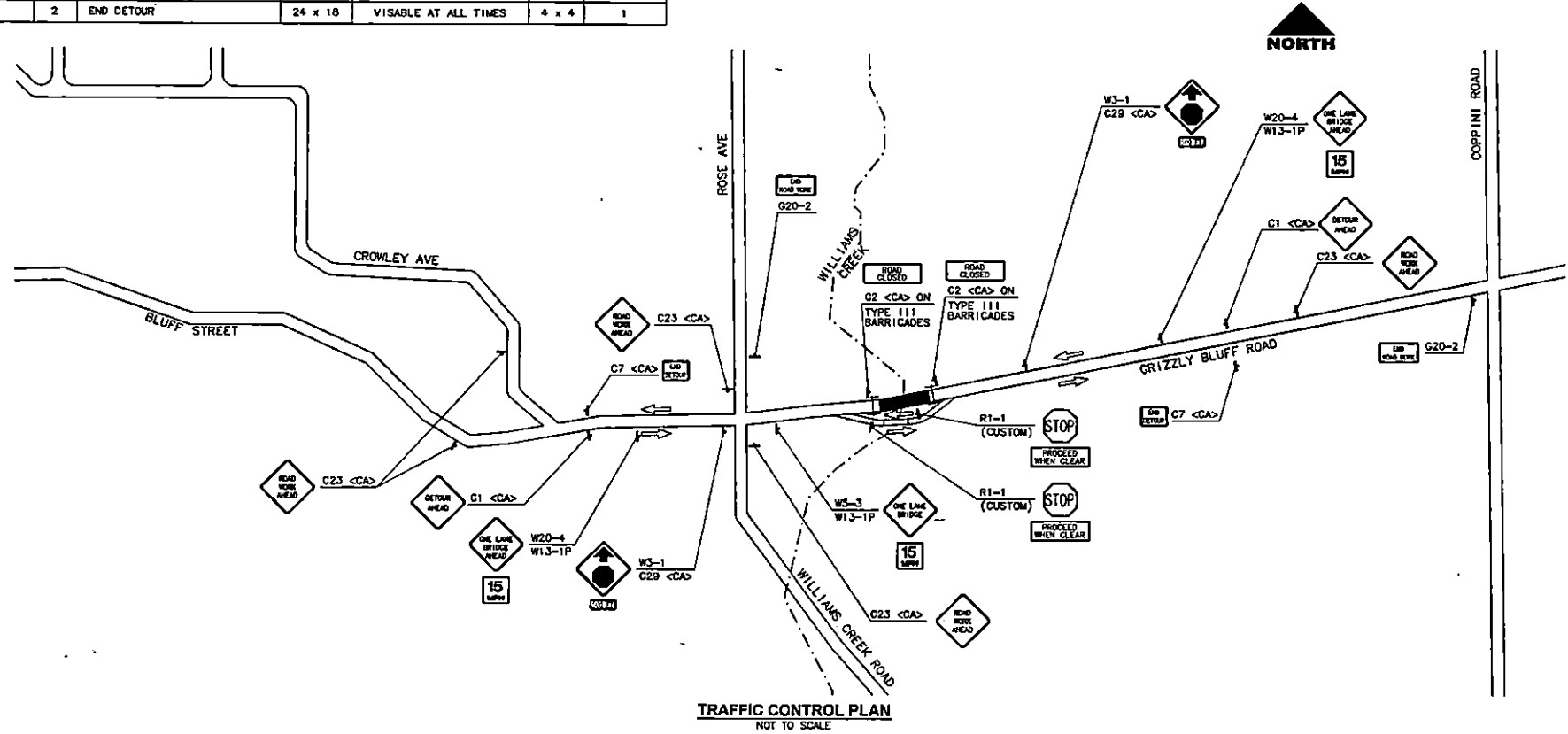

NOTE

- OBJECT MARKERS ARE TYPE P UNLESS OTHERWISE NOTED.
- CA MUTCD CODES SHOWN AS DESIGNATED BY <CA> WHICH INDICATES A CALIFORNIA SIGN CODE. OTHERWISE, FEDERAL MUTCD CODES ARE SHOWN.

LEGEND

- LIMIT OF STRIPING PATTERN
- DELINEATOR OR OBJECT MARKER
- (No.) PAVEMENT DELINEATION DETAIL
- * INSTALL ROADSIDE SIGN
- REMOVE ROADSIDE SIGN
- ▲ RELOCATE ROADSIDE SIGN
- ⋈ ROADSIDE SIGN 1 POST
- ⋈ EXISTING ROADSIDE SIGN
- 45 PAVEMENT MARKING NUMERALS

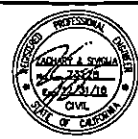

ROAD NAME: GRIZZLY BLUFF ROAD		MARK THOMAS & CO		COUNTY OF HUMBOLDT DEPARTMENT OF PUBLIC WORKS		SHEET 16 OF 29
DATE OF ONE INCH OR ORIGINAL DRAWING	ROAD NO: 2070	MILE POST: 12.0	DESIGNED BY: ED	GRIZZLY BLUFF ROAD BRIDGE REPLACEMENT		
PROJECT NO: 0413-2604(27)	CA MILE: 700002	CONTRACT NO: 041308	DRAWN BY: AM	SIGNING AND STRIPING PLAN		
IF NOT ONE INCH OF THIS SHEET, ADJUST SCALES ACCORDINGLY	DRAWING FILE NAME:	POST DATE: OCTOBER 2017	REVISION DATE: 03/01/2021	REVIEWED BY: JW	APPROVED BY: EB	

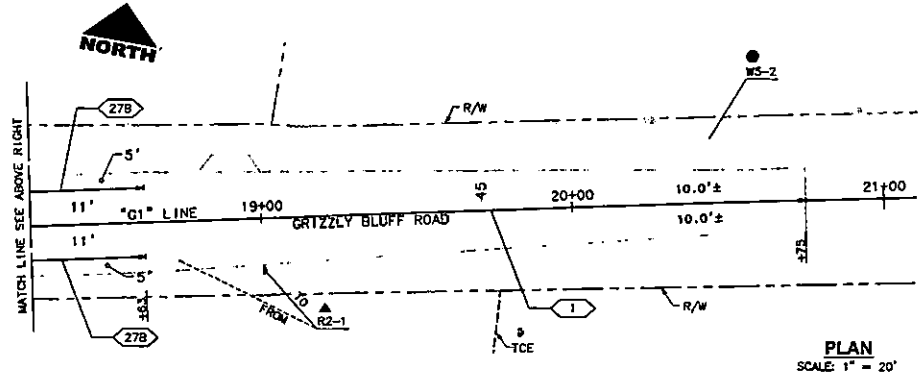
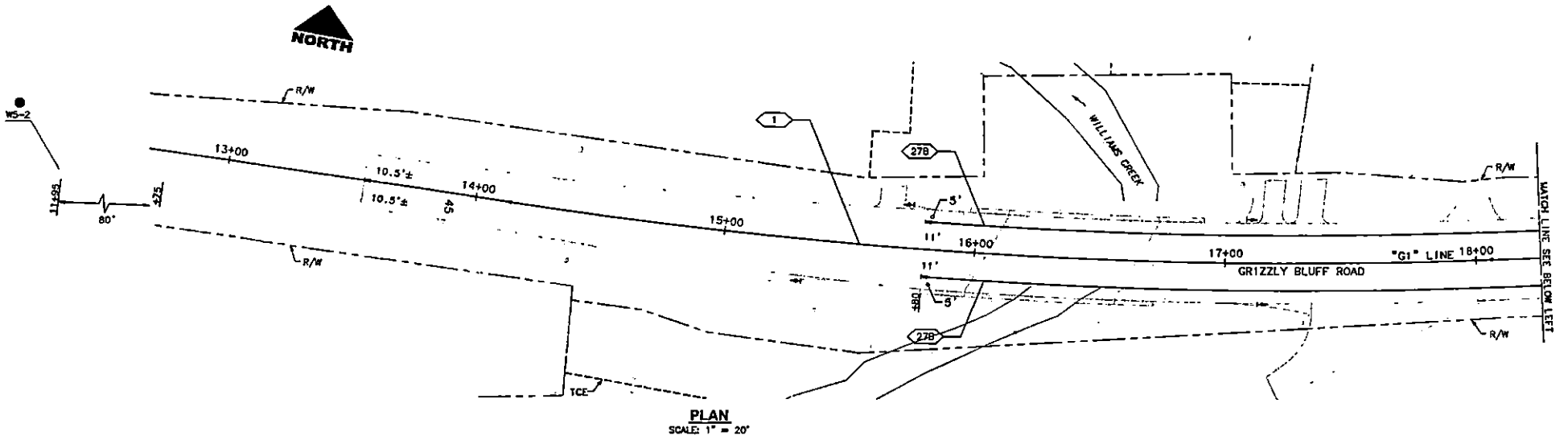

THIS PLAN ACCURATE FOR SIGNING AND STRIPING WORK ONLY

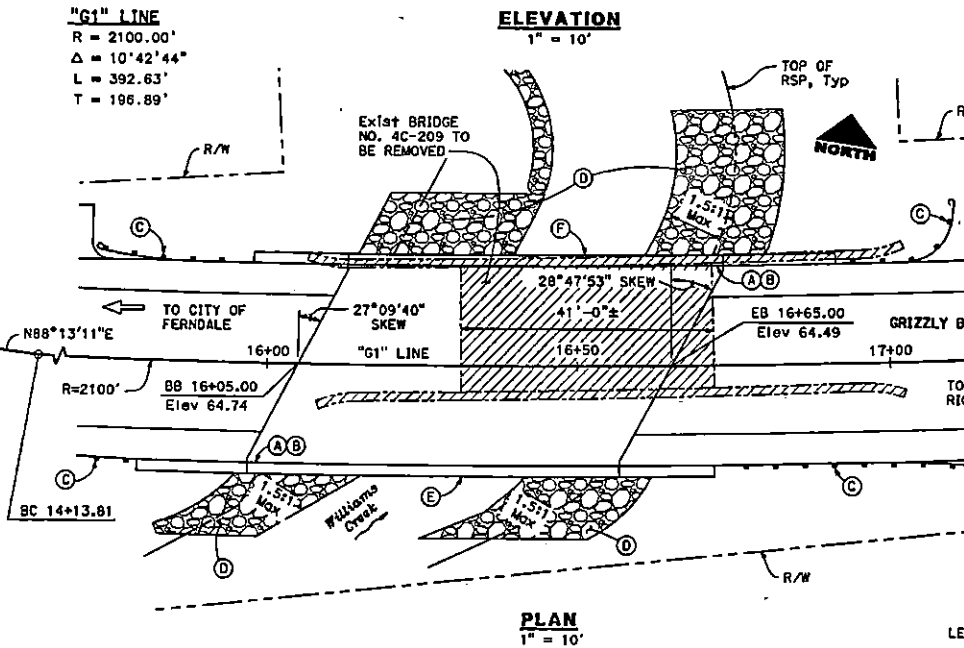
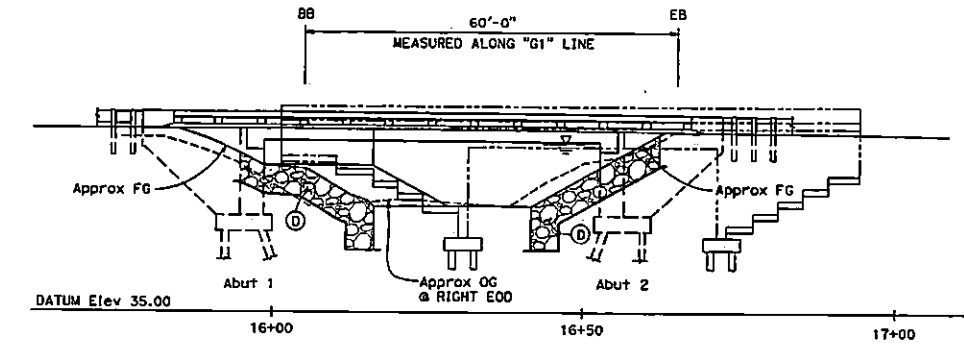
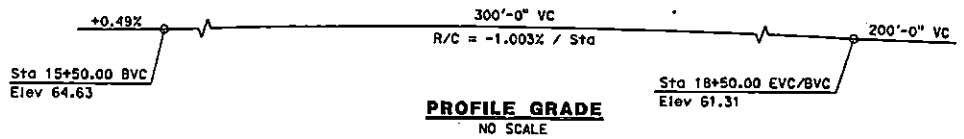

NOTE:
THE CONTRACTOR SHALL VERIFY ALL CONTROLLING FIELD DIMENSIONS BEFORE ORDERING OR FABRICATING ANY MATERIAL.

INDEX TO PLANS

NO.	TITLE
17	BRIDGE GENERAL PLAN
18	DECK CONTOURS
19	FOUNDATION PLAN
20	ABUTMENT 1 LAYOUT
21	ABUTMENT 2 LAYOUT
22	ABUTMENT DETAILS NO. 1
23	ABUTMENT DETAILS NO. 2
24	TYPICAL SECTION
25	LONGITUDINAL SECTION
26	UTILITIES DETAILS
27	DRAINAGE DETAILS
28	ROCK SLOPE PROTECTION
29	LOG OF TEST BORINGS

QUANTITIES

BRIDGE REMOVAL	1 LS
STRUCTURE EXCAVATION (BRIDGE)	504 CY
STRUCTURE BACKFILL (BRIDGE)	274 CY
6" WELDED STEEL PIPE CONDUIT	60 LF
FURNISH STEEL PILING (HP 14x89)	1,964 LF
DRIVE STEEL PILE (HP 14x89)	26 EA
PRESTRESSING CAST-IN-PLACE CONCRETE	1 LS
STRUCTURAL CONCRETE, BRIDGE FOOTING	74 CY
STRUCTURAL CONCRETE, BRIDGE	285 CY
JOINT SEAL (MR 1")	80 LF
BAR REINFORCING STEEL (BRIDGE)	50,208 LB
HEADED BAR REINFORCEMENT	28 EA
ROCK SLOPE PROTECTION (1/4 T, METHOD B)	358 CY
ROCK SLOPE PROTECTION (1 T, METHOD B)	8 CY
ROCK SLOPE PROTECTION (NO. 2 METHOD B)	119 CY
ROCK SLOPE PROTECTION FABRIC (CLASS B)	363 SQYD
MISCELLANEOUS METAL (BRIDGE)	305 LB
CONCRETE BARRIER (TYPE 80)	186 LF
COMMUNICATION CONDUIT (BRIDGE)	114 LF

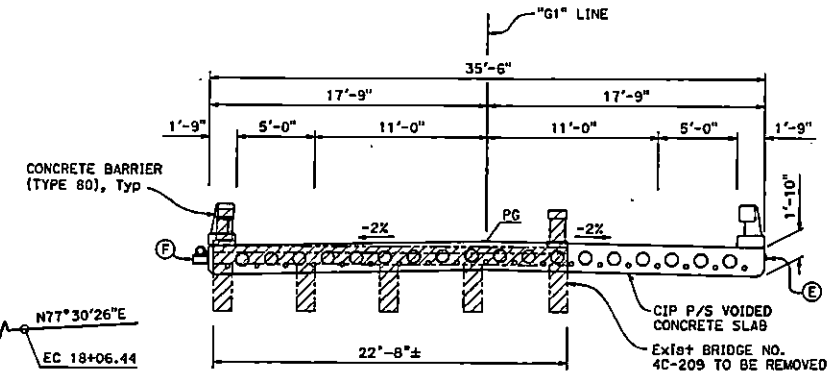

TYPICAL SECTION
1/4" = 1'-0"

NOTES:

- (A) Paint "WILLIAMS CREEK BRIDGE"
 - (B) Paint "BR NO. 4C-258"
 - (C) - ATS see "ROAD PLANS"
 - (D) Rock Slope Protection
 - (E) 1 - 4" Type 1 Communication Conduit
 - (F) 1 - 6" Galv Welded Steel Pipe Casing for Future Utilities
1. For "GENERAL NOTES", see "DECK CONTOURS" sheet.
 2. For "PILE DATA TABLE" and "HYDROLOGIC SUMMARY", see "FOUNDATION PLAN" sheet.

LEGEND:

- Indicates Existing Structure
- ▨ Indicates Bridge Removal

V:\Projects\22103\Grizzly Bluff Bridge Replacement\22103\Drawings\Structure\Sheet17.dwg 12/17/2017 2:31 PM



ROAD NAME: ORCHARD BLUFF ROAD	MILE POST: 10.27	MARK THOMAS & CO
PROJECT NO: 20100	EA NO: 300003	DESIGNED BY: TP
CONTRACT NO: 64B-3804(127)	SN NO: 40-158	DRAWN BY: CB
ISSUED FILE NAME:	REVISION DATE: 03/04/2008	CHECKED BY: VS
DATE DATE: DECEMBER 2007		

COUNTY OF HUMBOLDT
DEPARTMENT OF PUBLIC WORKS
WILLIAMS CREEK BRIDGE (4C-258)

SHEET
18
OF
28

DECK CONTOURS

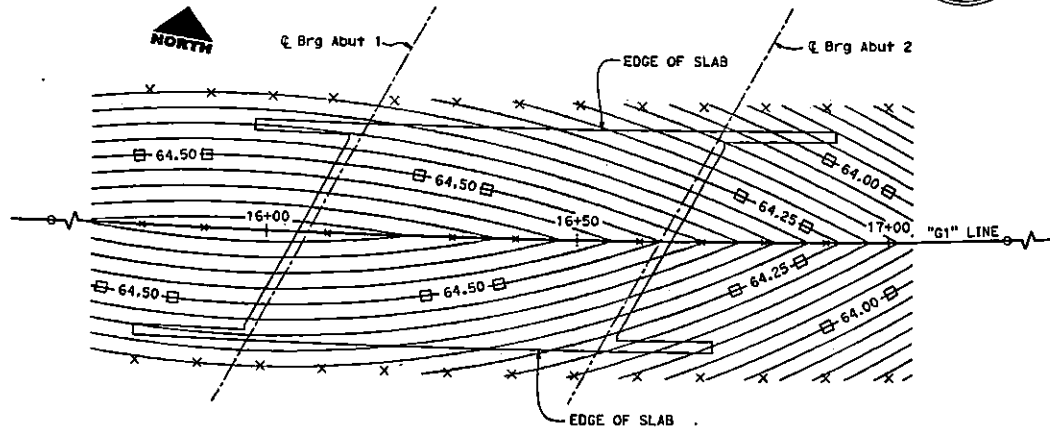

DECK CONTOURS
1" = 10'

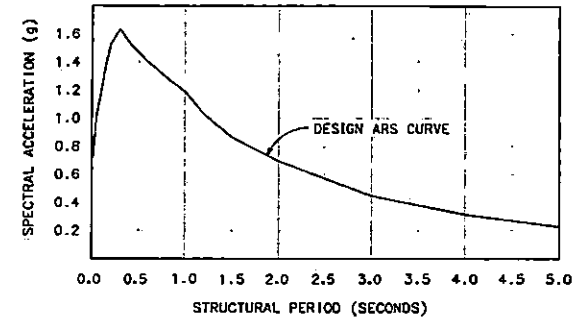

ARS CURVE
(5% DAMPING)

- NOTES:
1. Contour Interval is 0.05 feet.
 2. Contours do not include camber or falsework settlement/camber.
 3. X- Indicates 10 foot Intervals along "G1" Line
 4. □- Indicates quarter foot contour.

GENERAL NOTES
LOAD AND RESISTANCE FACTOR DESIGN

DESIGN:
AASHTO LRFD Bridge Design Specifications, 6th edition and the California Amendments, preface dated January 2014.

SEISMIC DESIGN:
Caltrans Seismic Design Criteria (SDC), Version 1.7 dated April 2013.

DEAD LOAD:
Includes 35 psf for future wearing surface.

LIVE LOADING:
HL93 and Permit Design Load.

SEISMIC LOADING:
Soil Profile: Vs30 = 200 m/s (660 ft/s)
Moment Magnitude: 7.8
Peak Ground Acceleration 0.7g
See ARS Curve

CONCRETE:
f_y = 60 ksi
f'_c = 3.6 ksi unless otherwise noted
n = 8
See "PRESTRESSING NOTES" on "LONGITUDINAL SECTION" sheet.

PILE:
See "PILE DATA TABLE" on "FOUNDATION PLAN" sheet.

STANDARD PLANS DATED 2010

A10A	ABBREVIATIONS (SHEET 1 OF 2)
RSP A10B	ABBREVIATIONS (SHEET 2 OF 2)
A10C	LINES AND SYMBOLS (SHEET 1 OF 3)
A10D	LINES AND SYMBOLS (SHEET 2 OF 3)
A10E	LINES AND SYMBOLS (SHEET 3 OF 3)
RSP A10F	LEGEND - SOIL (SHEET 1 OF 2)
RSP A10G	LEGEND - SOIL (SHEET 2 OF 2)
A62C	LIMITS OF PAYMENT FOR EXCAVATION AND BACKFILL BRIDGE
B0-1	BRIDGE DETAILS
B0-13.	BRIDGE DETAILS
RSP B6-21	JOINT SEALS (MAXIMUM MOVEMENT RATING = 2")
RSP B8-5	CAST-IN-PLACE POST-TENSIONED GIRDER DETAILS
RSP B11-60	CONCRETE BARRIER TYPE 80 (SHEET 1 OF 2)

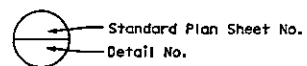

	Structural Concrete, Bridge
	Structural Concrete, Bridge (f' _c = 5.0 ksi @ 28 days)
	Structural Concrete, Bridge Footing

CONCRETE STRENGTH AND TYPE LIMITS
NO SCALE

X:\Projects\04-11111-0001\Drawings\Struct\Williams\4C-258.dwg 17/07/2007 2:33 PM

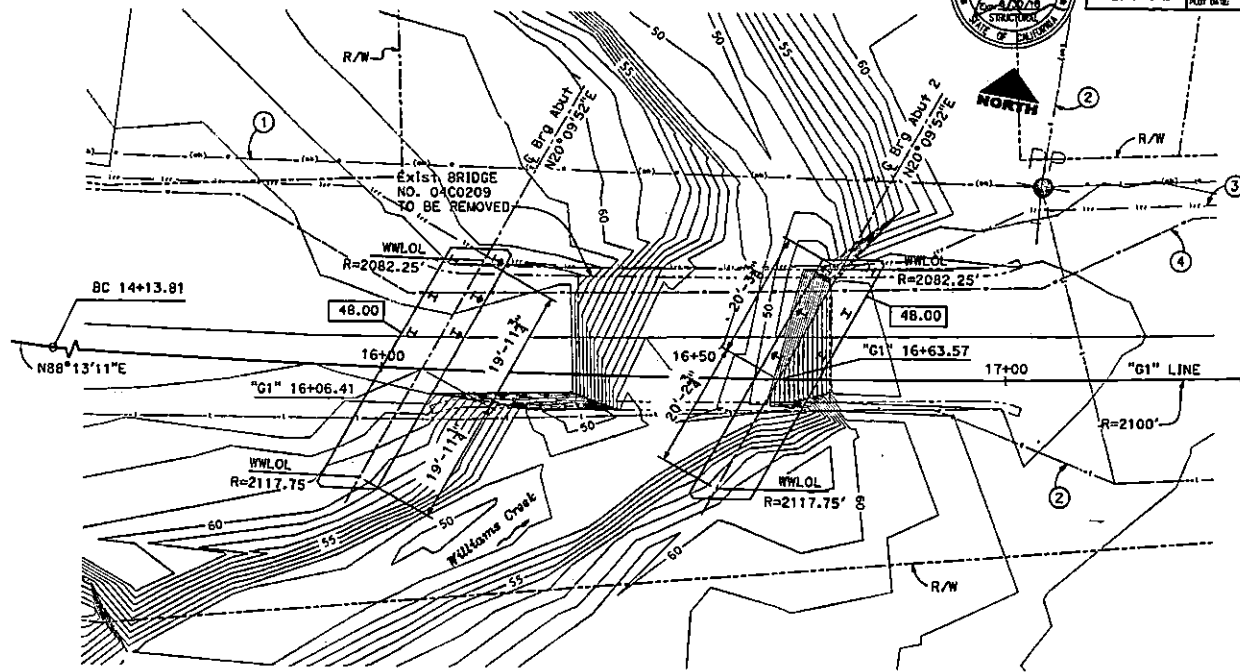

UTILITIES

- ① Exist Electrical Overhead Line to remain, see "ROAD PLANS"
- ② Exist Telephone Line to be relocated by others
- ③ Exist Irrigation Line to be abandoned. Relocated by others after project completion
- ④ Abandoned Water Line (unknown owner)

LEGEND:

- Indicates Bottom of Footing Elevation (feet)
- Indicates Existing Structure
- Indicates HP Pile (all piles not shown)

BENCHMARK

Bearings shown are based on Record of Survey book 70 page 64, which was filed to Record of Survey book 58 pages 120 to 123 (N18°07'04"W between found monument 2 & 3)

NGS BM P1468 (PID LV1290) having elevation of 61.97 feet. (NGVD 29 Datum)

"G1" LINE
 R = 2100.00'
 Δ = 10°42'44"
 L = 392.63'
 T = 196.89'

PLAN
 1" = 10'

PILE DATA TABLE

Location	Pile Type	Nominal Resistance (kips)		Design Tip Elevations (ft)	Specified Tip Elevations (ft)	Nominal Driving Resistance (kips)
		Compression	Tension			
Abut 1	Class 200 HP 14x89	300	0	-19.58(a), -1.58(b)	-19.58	300
Abut 2	Class 200 HP 14x89	300	0	-31.58(a), 5.42(b)	-31.58	300

NOTE:
 Design tip elevations for Abutments are controlled by (a) Compression, (b) Lateral Load.

NOTE:
 THE CONTRACTOR SHALL VERIFY ALL CONTROLLING FIELD DIMENSIONS BEFORE ORDERING OR FABRICATING ANY MATERIAL.

HYDROLOGIC SUMMARY

Drainage Area:	5.9 Square Miles		
	Design Flood	Base Flood	Overtopping Flood
Frequency (Years)	50	100	200
Discharge (Cubic Foot per Sec)	1,725	1,985	2,230
Water Surface (Elevation at Bridge)	61.7	62.4	62.5

Flood plain data is based upon information available when the plans were prepared and is shown to meet County requirements. The accuracy of said information is not warranted by the County and interested or affected parties should make their own investigation.

V:\Projects\08-11111\0819-3004\Drawings\Structural\18-01-12\12/17/2007 3:02 PM



ROAD NAME: CRUZLEY BLUFF ROAD	MILE POSTS: 10.51	MARK THOMAS & CO
ROAD NO.: 3000	EA NO.: 02000	DESIGNED BY: TP
PROJECT NO.: WLLS-1804(17)	BR NO.: 4C-208	DRAWN BY: CR
CONTRACT NO.: 58-009	DRAWING FILE NAME:	REVIEWED BY: JK
PLAT DATE: DECEMBER 2017	REVISION DATE: 04/02/2020	CHECKED BY: VS

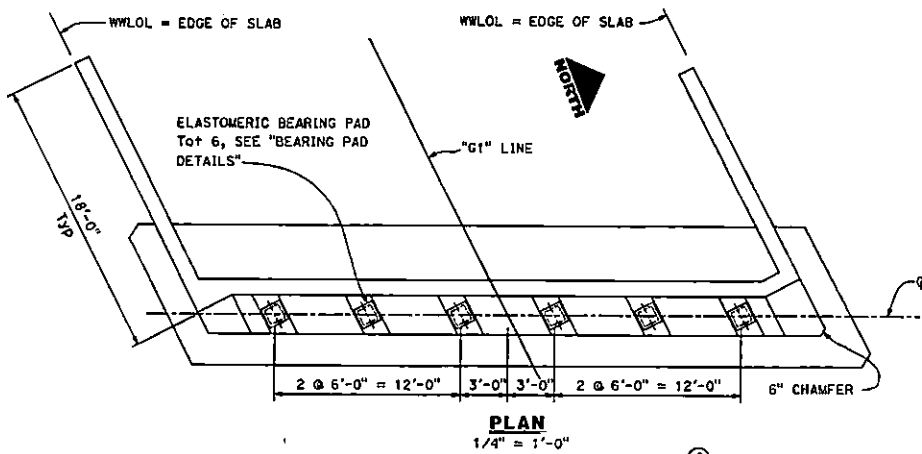

PLAN
1/4" = 1'-0"

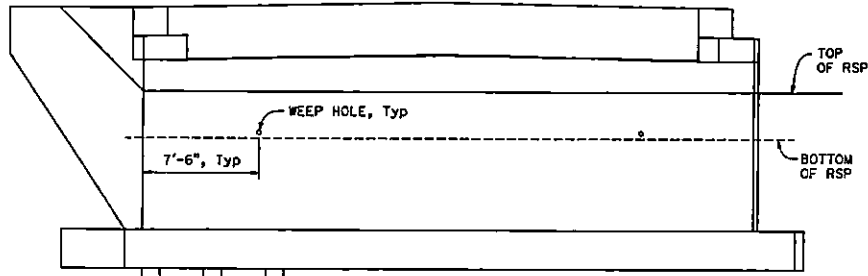

ELEVATION
1/4" = 1'-0"

ALL PILES NOT SHOWN

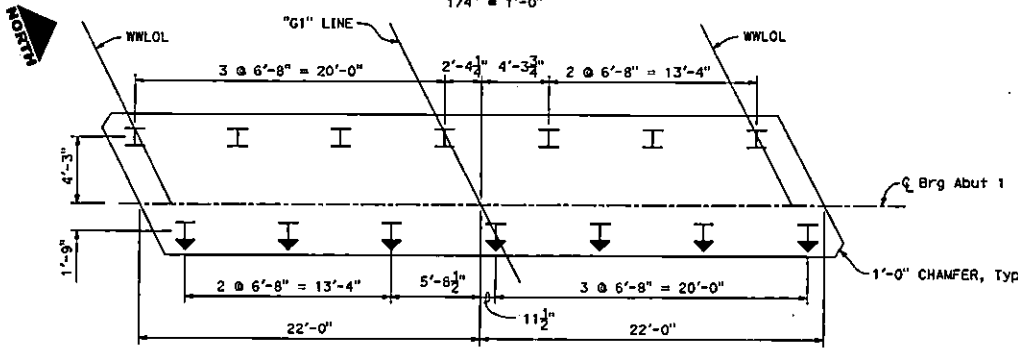

FOOTING PLAN
1/4" = 1'-0"

NOTE:
THE CONTRACTOR SHALL VERIFY ALL CONTROLLING FIELD DIMENSIONS BEFORE ORDERING OR FABRICATING ANY MATERIAL.

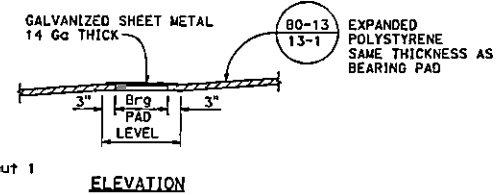

ELEVATION

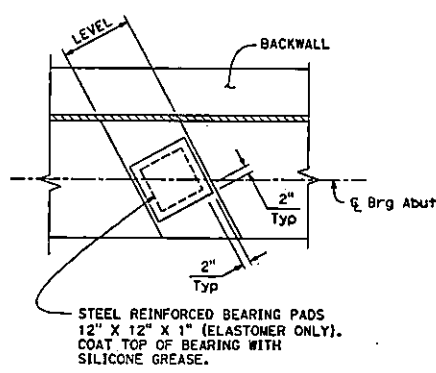

PLAN BEARING PAD DETAILS
NO SCALE

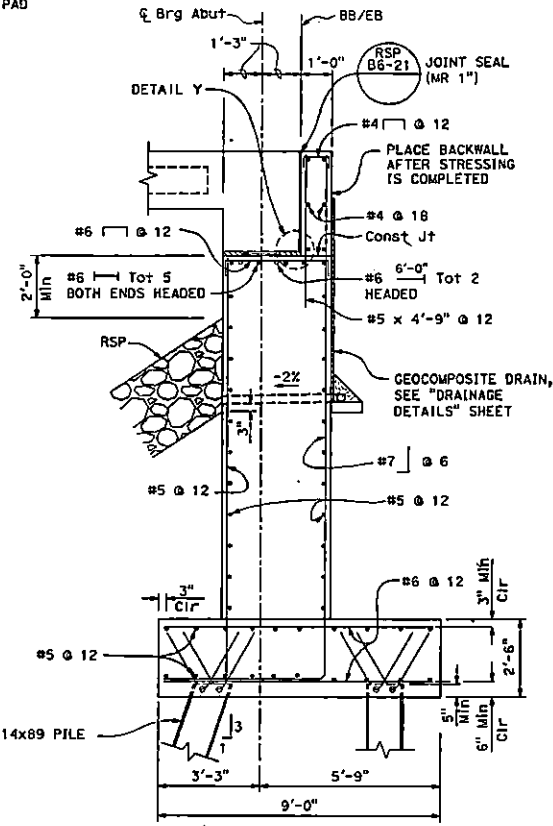

SECTION A-A
1/2" = 1'-0"

- NOTES:
1. For "DETAIL Y", see "ABUTMENT 2 LAYOUT" sheet.
 2. For HP Pile anchor details, see "ABUTMENT DETAILS NO. 1" sheet

- LEGEND:
- Indicates Vertical Pile
 - Indicates Battered Pile

C:\Users\Bart\OneDrive\Documents\Projects\Williams Creek Bridge\4C-208\Drawings\Structures\Sheet\20-29.dwg 12/17/2017 3:01 PM



ONE IS ONE EACH OF ORIGINAL DRAWING IF NOT ONE EACH ON THIS SHEET, AMEND SCALES ACCORDINGLY	ROAD NAME: GRIFFIN BLUFF ROAD ROAD NO: 2222 PROJECT NO: WLB-1004(177) CONTRACT NO: 84208 DRAWING FILE NAME: PLOT DATE: DECEMBER 2017	SHEET NO: 10 21 (A NO: 100001) BR NO: 40-254 REVISION DATE: 03/04/2006	MARK THOMAS & CO DESIGNED BY: TP DRAWN BY: CE REVISION BY: JR CHECKED BY: VS	COUNTY OF HUMBOLDT DEPARTMENT OF PUBLIC WORKS WILLIAMS CREEK BRIDGE (40-254) ABUTMENT 2 LAYOUT	SHEET 21 OF 29
--	---	---	--	--	---------------------------------------

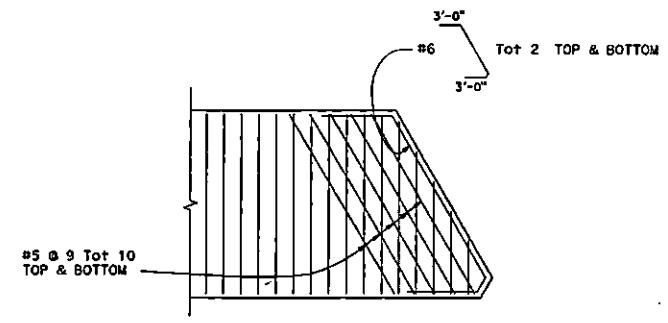
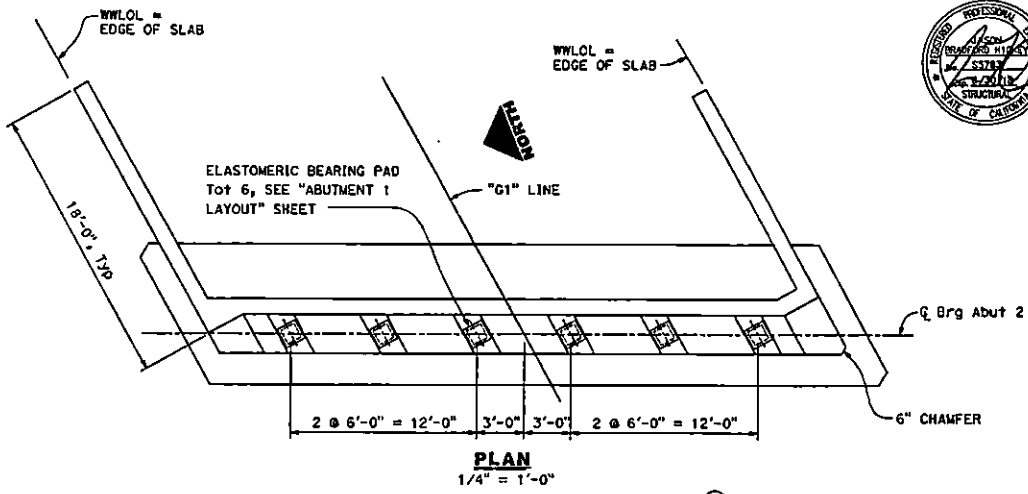

TYPICAL FOOTING CORNER DETAIL
 3/8" = 1'-0"
 NOTE: Longitudinal Footing Reinf not shown for clarity

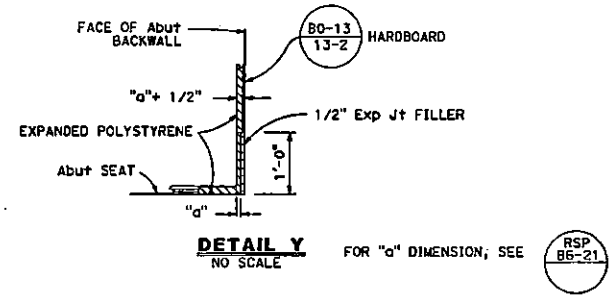
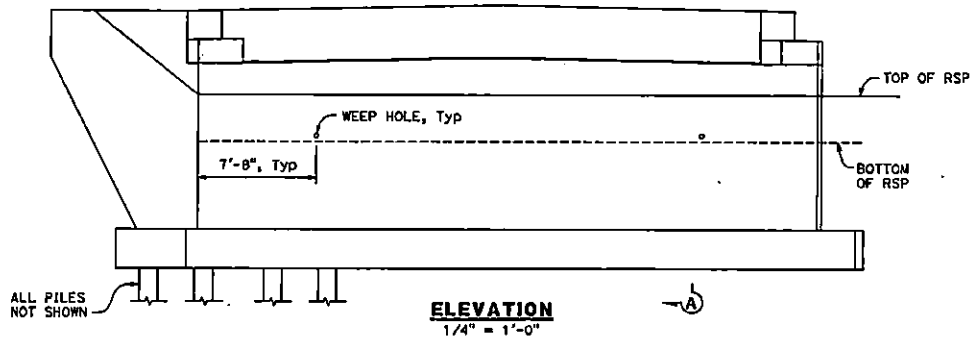

NOTES:
 1. For "SECTION A-A", see "ABUTMENT 1 LAYOUT" sheet.
 2. For location of "DETAIL Y", see "ABUTMENT 1 LAYOUT" sheet.

LEGEND:
 Indicates Vertical Piles
 Indicates Battered Piles

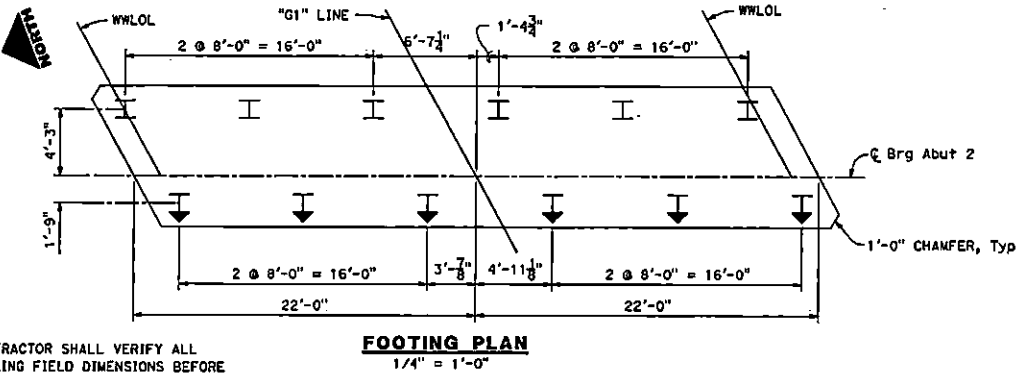

NOTE:
 THE CONTRACTOR SHALL VERIFY ALL CONTROLLING FIELD DIMENSIONS BEFORE ORDERING OR FABRICATING ANY MATERIAL.

V:\Projects\10-11111 City of Grays Bluffs Replacement\1007\Drawings\Structure\Drawings\10-11111-02.dwg 12/17/2017 3:05 PM



ROAD NAME: GREATLY IMPROVED ROAD ROAD NO.: 20700 PROJECT NO.: WLB-288(127) CONTRACT NO.: 09-0308 DRAWING FILE NAME: PLOT DATE: DECEMBER 2017 DESIGNER: MARK THOMAS & CO. CHECKED BY: TP DATE: 12/20/17 SCALE: AS SHOWN DATE: 12/20/17	COUNTY OF HUMBOLDT DEPARTMENT OF PUBLIC WORKS WILLIAMS CREEK BRIDGE (4C-288) ABUTMENT DETAILS NO. 1	SHEET 22 OF 29
---	---	---------------------------------------

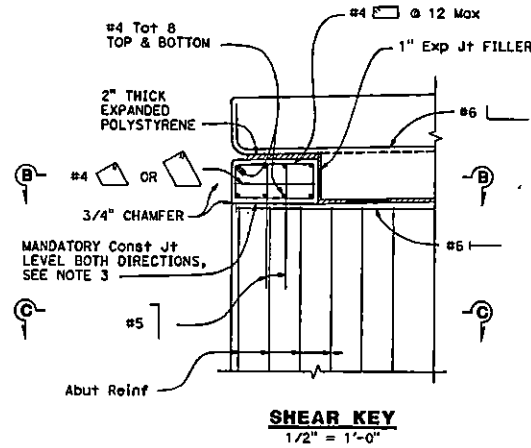

SHEAR KEY
1/2" = 1'-0"

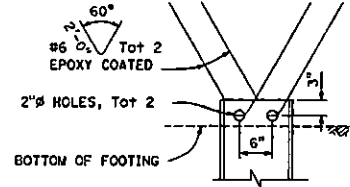

HP 14x89 PILE ANCHOR
1" = 1'-0"

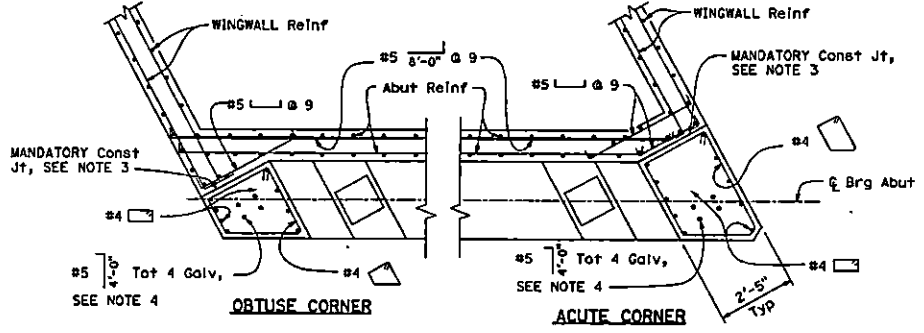

SECTION B-B
1/2" = 1'-0"

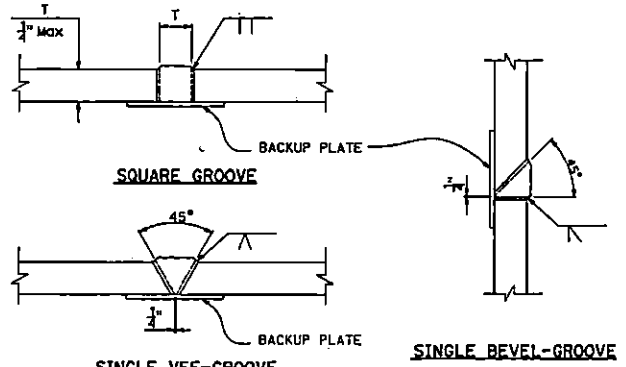

PILE WELDING DETAIL - BUTT JOINTS
NO SCALE

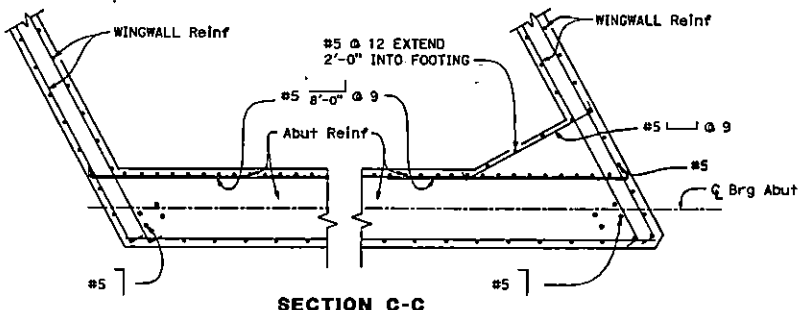

SECTION C-C
1/2" = 1'-0"

NOTE:
THE CONTRACTOR SHALL VERIFY ALL
CONTROLLING FIELD DIMENSIONS BEFORE
ORDERING OR FABRICATING ANY MATERIAL.

Note: Abutment 1 shown, Abutment 2 similar.

- NOTES:
1. Single Vee-Groove and Square Groove permitted for all positions.
 2. Single Bevel-Groove permitted for horizontal joints only.
 3. Mandatory construction joint shall be smooth finished and lined with 15 pound building paper.
 4. Main vertical shear key reinforcement shall be centered transversely in shear key.

W:\Projects\CA-11111\Drawings\Sheet\Sheet\Revisions\2017\12\12\17\2017_12\12\17_12\17_12.dwg 12/17/2017 3:57 PM



ROAD NAME: ONEZLY BLUFF ROAD	MARK THOMAS & CO
ROAD NO: 20-20	MILE POST: 16.21
PROJECT NO: WLS-2004(177)	DATE: 02/02/04
CONTRACT NO: 144709	DATE: 04-25-04
DRAWING FILE NAME:	REVISION DATE: 11/02/2004
PLAT DATE: DECEMBER 2001	CHECKED BY: VE

COUNTY OF HUMBOLDT DEPARTMENT OF PUBLIC WORKS	SHEET 23
WILLIAMS CREEK BRIDGE (4C-266)	OF 29
ABUTMENT DETAILS NO. 2	

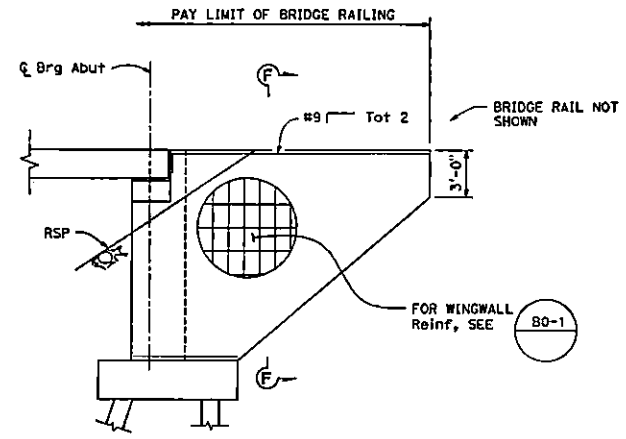

ABUTMENT WINGWALL ELEVATION
1/4" = 1'-0"

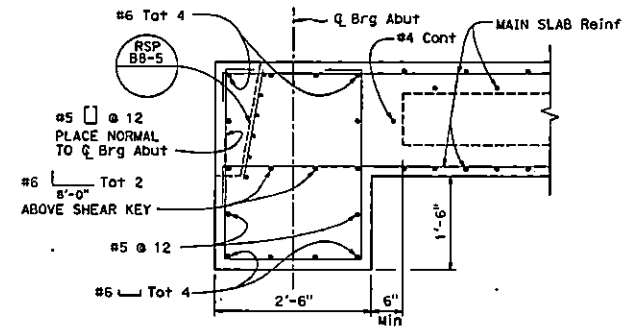

END DIAPHRAGM
1" = 1'-0"

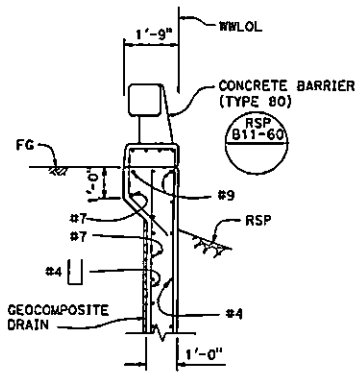

SECTION F-F
1/2" = 1'-0"

NOTE:
For details and reinforcement not shown, see Revised Standard Plans B11-65.

NOTE:
THE CONTRACTOR SHALL VERIFY ALL CONTROLLING FIELD DIMENSIONS BEFORE ORDERING OR FABRICATING ANY MATERIAL.

W:\Projects\24-1011_02\24 Bldg Bridge Replacement\2400\Drawings\Structure Detail\22-23 CG Detail-2.dwg 12/01/2003 3:08 PM



ROAD NAME: CRISLY BLUFF ROAD	MARK THOMAS & CO	COUNTY OF HUMBOLDT DEPARTMENT OF PUBLIC WORKS	SHEET 24 OF 29
ROAD NO: 2020	MILE POST: 10.21	PROJECT NO: HML-980(177)	DESIGNED BY: SP
CONTRACT NO: 98-030	CA REG. NO: 40-258	CONTRACT FILE NO: 98-030	DRAWN BY: JG
DATE: DECEMBER 2017	REVISION DATE: 10/20/2020	PROJECT FILE NAME: WILLIAMS CREEK BRIDGE (40-2001)	CHECKED BY: VS

WILLIAMS CREEK BRIDGE (40-2001)
TYPICAL SECTION

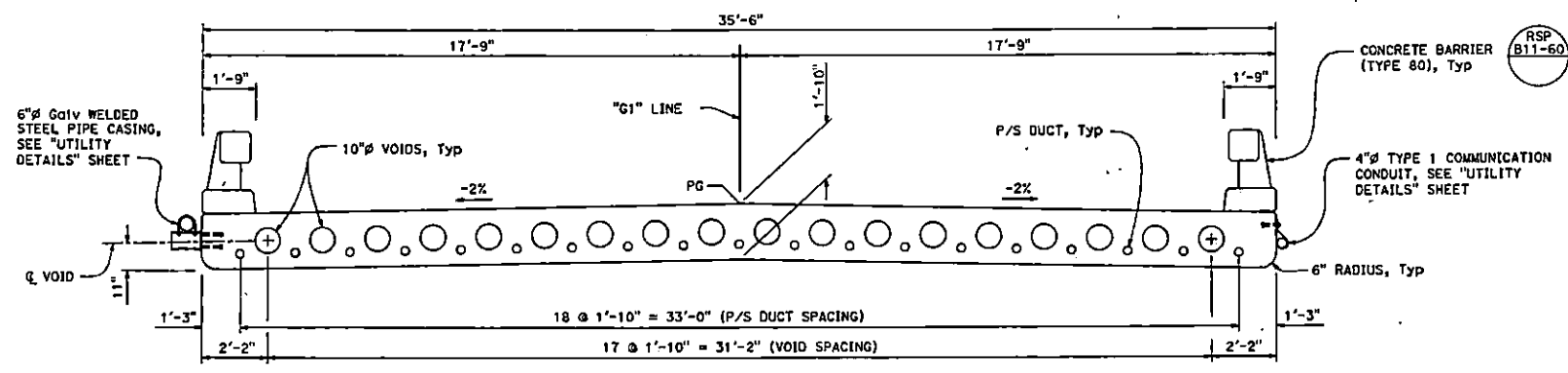

TYPICAL SECTION
1/2" = 1'-0"

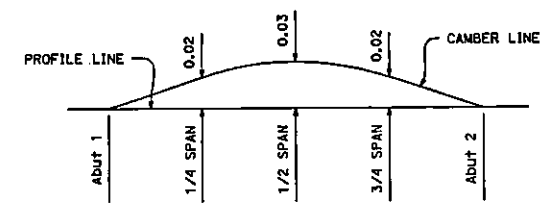

NOTE: Does not include allowance for falsework settlement

CAMBER DIAGRAM
NO SCALE

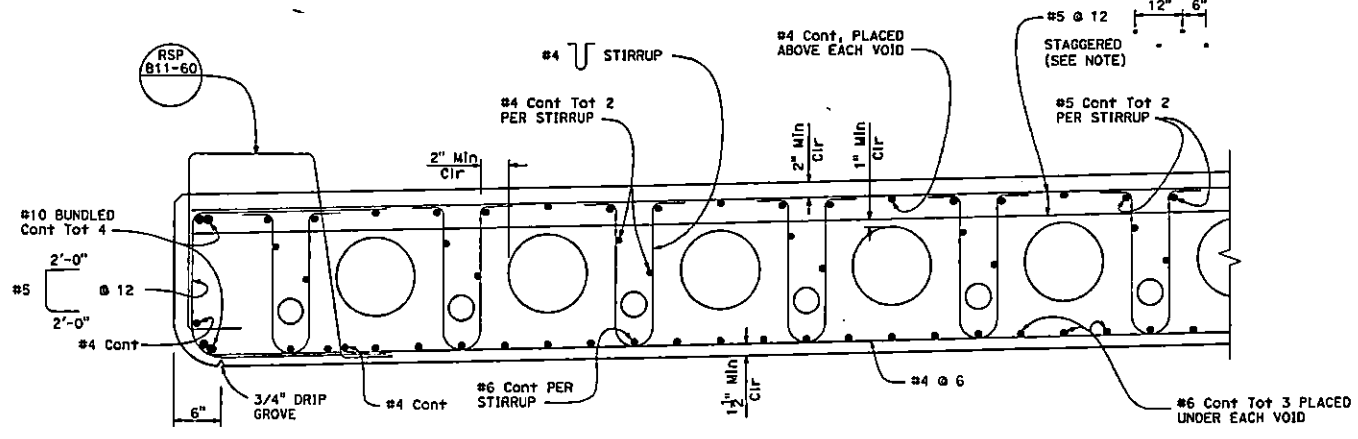

PART TYPICAL SECTION
1 1/2" = 1'-0"

NOTE:
THE CONTRACTOR SHALL VERIFY ALL CONTROLLING FIELD DIMENSIONS BEFORE ORDERING OR FABRICATING ANY MATERIAL.

NOTES:
1. Adjust reinforcement as necessary to place prestress ducts.
2. Steel void formers shall not be permitted.

N:\Users\jg\OneDrive\Documents\Projects\Williams Creek Bridge\40-2001\Drawings\12/17/2017 3:13 PM



DATE OF ONE COPY OF ORIGINAL DRAWING	ROAD NAME	CRIZLY BLUFF ROAD	MARK THOMAS & CO
PROJECT NO.	ROAD NO.	STATE POST MILE POSTS	DESIGNED BY
CONTRACT NO.	CONTRACT NO.	CA REG. NO.	DRAWN BY
IF NOT ONE COPY ON THIS SHEET, ADJUST SCALE ACCORDINGLY	DRAWING FILE NAME	DATE	REVIEWED BY
	PLAT DATE	REVISION DATE	CHECKED BY

COUNTY OF HUMBOLDT
DEPARTMENT OF PUBLIC WORKS
WILLIAMS CREEK BRIDGE (40-268)
LONGITUDINAL SECTION

SHEET
25
OF
29

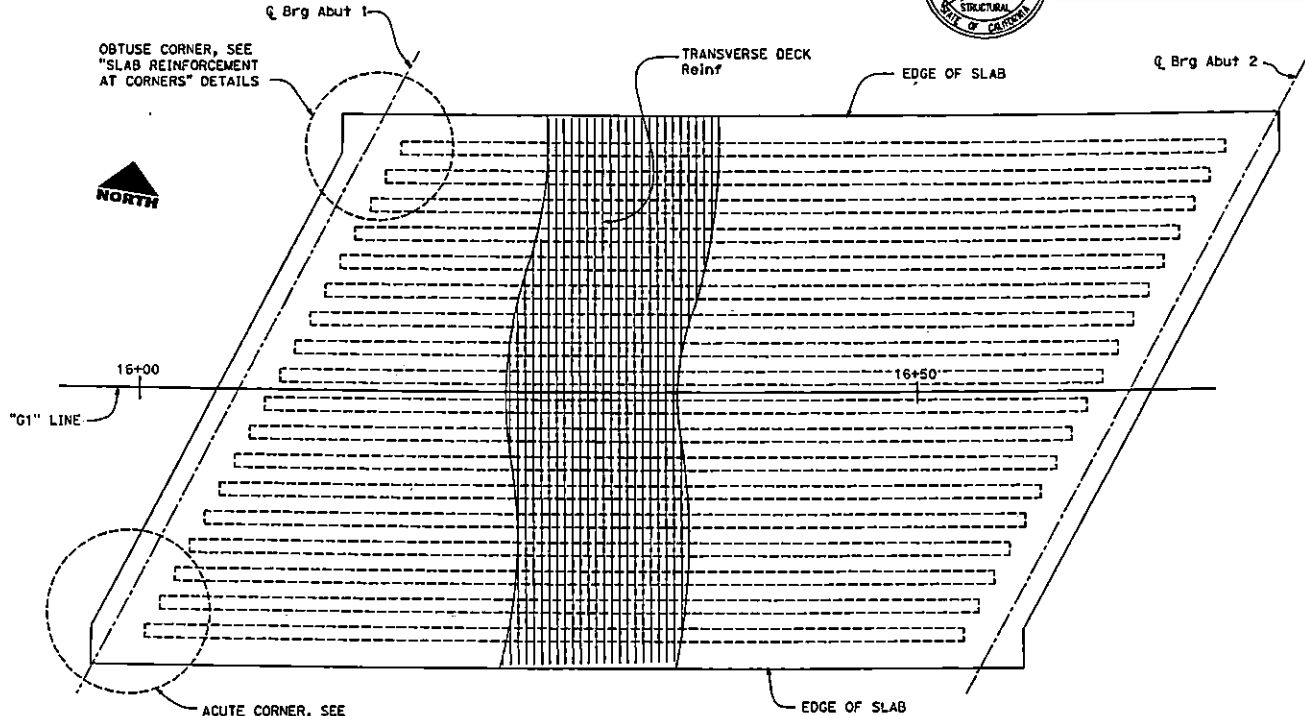

VOID LAYOUT
1/4" = 1'-0"

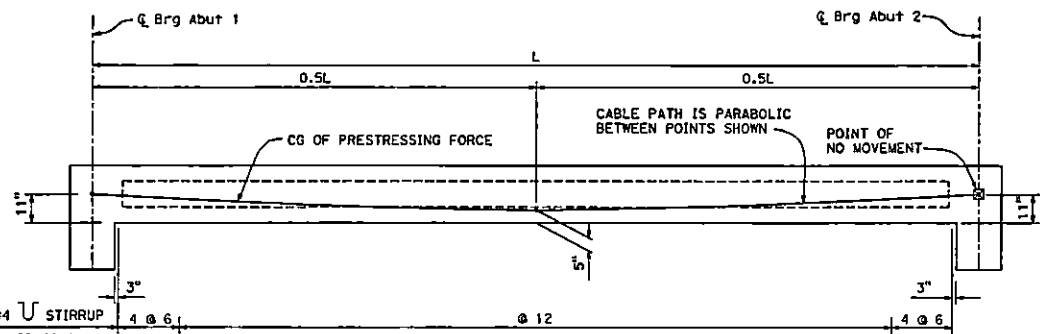

LONGITUDINAL SECTION
NO SCALE

PRESTRESSING NOTES

270 ksi Low Relaxation Strand:
 $P_{jack} = 8,650$ kIps
 Anchor Set = 0.375"
 Friction coefficients
 Curvature, $\mu = 0.15/\text{rad}$
 Wobble, $K = 0.0002/\text{ft}$
 Distribute the prestressing force uniformly across the slab.
 Concrete: $f'_c = 5.0$ ksi @ 28 days
 $f'_{ci} = 4.0$ ksi @ time of stressing
 Contractor shall submit elongation calculations based on initial stress at $\sigma = 0.923$ times jacking stress.
 One end stressing shall be performed from either abutment.

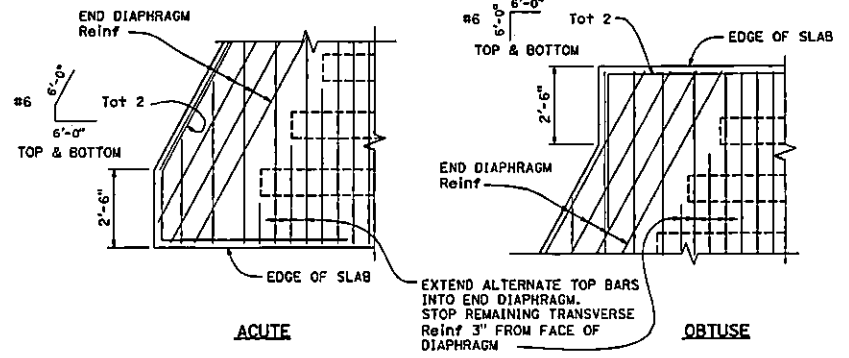

SLAB REINFORCEMENT AT CORNERS
1/2" = 1'-0"

NOTE:
THE CONTRACTOR SHALL VERIFY ALL CONTROLLING FIELD DIMENSIONS BEFORE ORDERING OR FABRICATING ANY MATERIAL.

V:\Projects\16-1111 Crizly Bluff Bridge Replacement\1607\Drawings\Structure Drawings\16-1111 Crizly Bluff July 12/17/2017 3:16 PM



ROAD NAME: CRUZLY BLUFF ROAD	MILE POST: 10.71	MARK THOMAS & CO	COUNTY OF HUMBOLDT DEPARTMENT OF PUBLIC WORKS	SHEET 26 OF 29
PROJECT NO.: WMS-3804(177)	CA PROJ. NUMBER	DESIGNED BY: JP		
CONTRACT WILL NUMBER	SP. NO.: 4C-258	DRAWN BY: CE	WILLIAMS CREEK BRIDGE (4C-288)	
DRAWING FILE NAME	REVISION DATE: 04/14/2008	CHECKED BY: VS		
IF NOT ONE WORK ON THIS SHEET, ADJUST SCALE ACCORDINGLY			UTILITY DETAILS	
PLAT DATE: DECEMBER 2007	REVISION DATE: 04/14/2008			

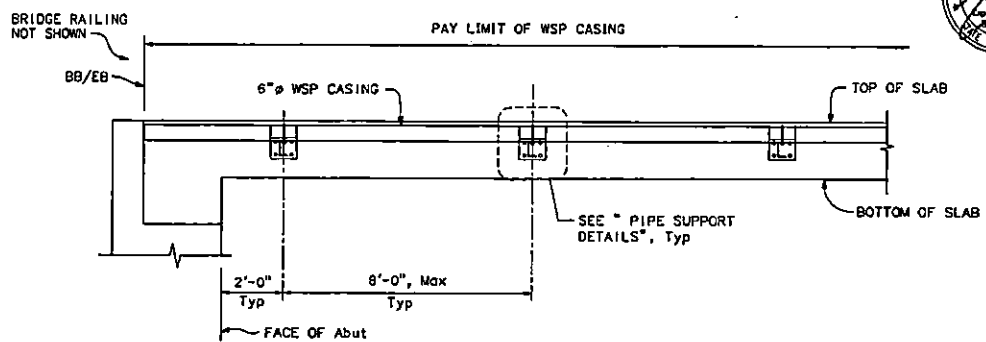

PIPE SUPPORT LAYOUT
1/2" = 1'-0"

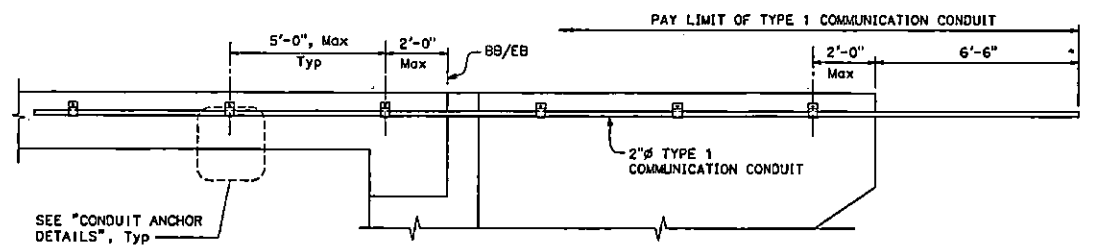

CONDUIT ANCHOR LAYOUT
1/2" = 1'-0"

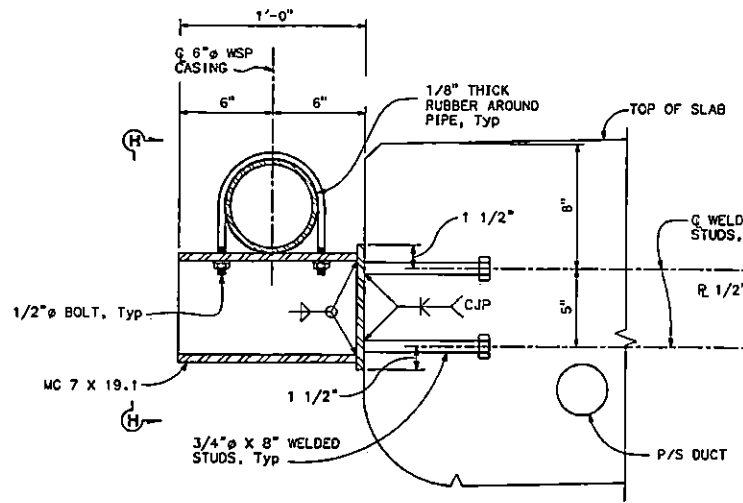

PIPE SUPPORT DETAILS
3" = 1'-0"

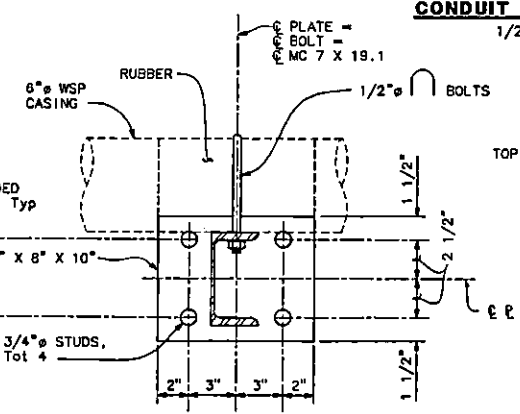

SECTION H-H
3" = 1'-0"

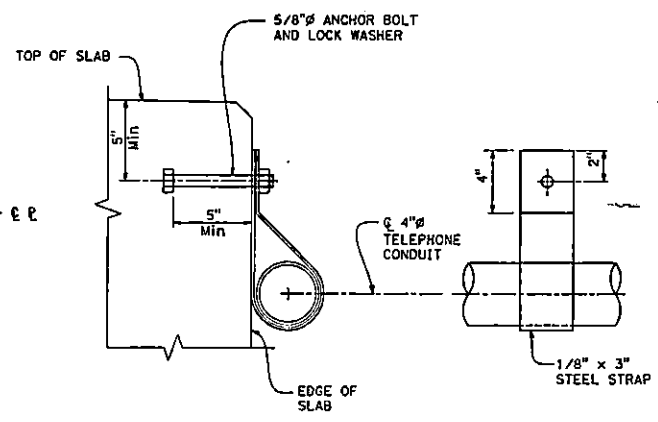

CONDUIT ANCHOR DETAILS
3" = 1'-0"

- NOTES:
1. Structural steel ASTM A36, Fy=36 Ksi
 2. All bolts ASTM A325.
 3. All steel Nuts, Washers and Steel Members shall be hot dipped galvanized. All field welds and damaged surfaces shall be cleaned and treated with 2 applications of zinc-rich primer.
 4. Where dissimilar metals such as galvanized steel and ductile iron are to be placed against each other, provide separating medium of polyethylene tape 1/8" thick to prevent corrosion.

NOTE:
THE CONTRACTOR SHALL VERIFY ALL CONTROLLING FIELD DIMENSIONS BEFORE ORDERING OR FABRICATING ANY MATERIAL.

\\humblt\ba-1111\city\bill\Bridg\Bridg\Drawings\Drawings\Structure\Bridges\08\02\04\08\12/11/2007 3:17 PM



ROAD NAME: ORZELY BLUFF ROAD		MARK THOMAS & CO		COUNTY OF HUMBOLDT DEPARTMENT OF PUBLIC WORKS		SHEET
ROAD NO: 2530	MILE POST: 10.21	DESIGNED BY: JP	WILLIAMS CREEK BRIDGE (4G-258)			27
PROJECT NO: WLS-BRM(17)	EA NO: 20002	DRAWN BY: GB	DRAINAGE DETAILS			OF
CONTRACT NO: 58-202	BN NO: 4C-258	REVIEWED BY: JP				29
DRAWING FILE NAME:		REVISION DATE: 03/20/2022				
PLOT DATE: DECEMBER 2017						

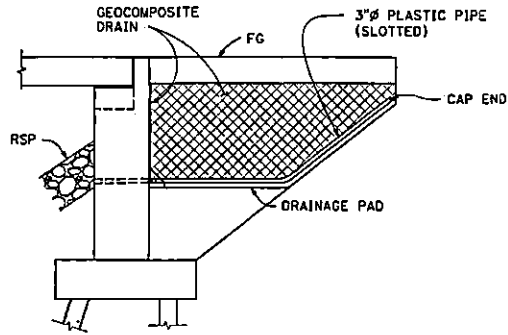

WINGWALL ELEVATION
1/4" = 1'-0"

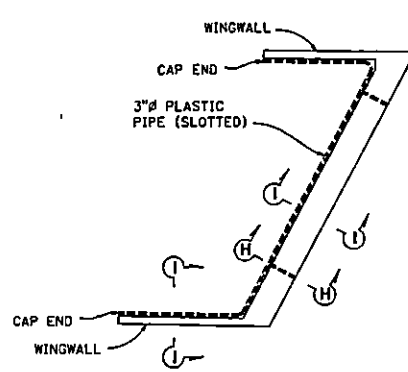

PLAN
NO SCALE

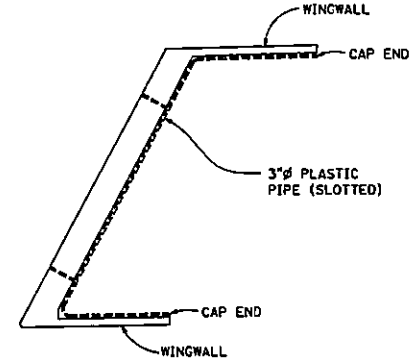

NOTE:
Geocomposite drain, cement treated permeable base, and 3" slotted plastic pipe continuous behind abutment. Cap ends of pipe. Provide "Tee" connection at each 4" drain.

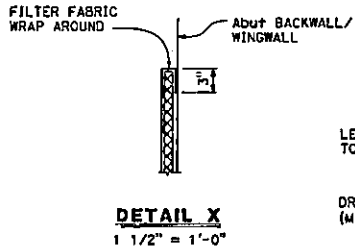

DETAIL X
1 1/2" = 1'-0"

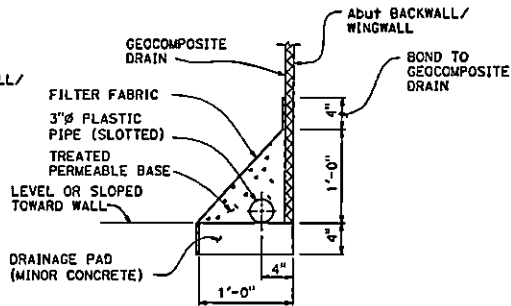

SECTION I-I
1 1/2" = 1'-0"

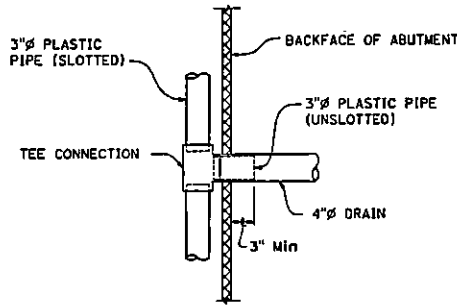

PART PLAN
1 1/2" = 1'-0"

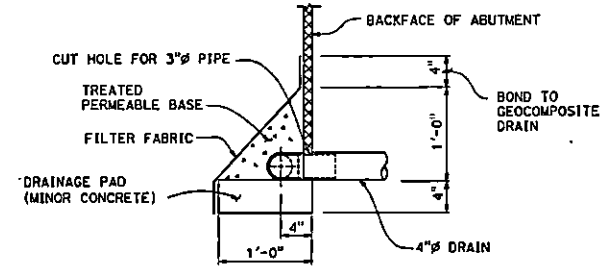

SECTION H-H
1 1/2" = 1'-0"

NOTE:
THE CONTRACTOR SHALL VERIFY ALL CONTROLLING FIELD DIMENSIONS BEFORE ORDERING OR FABRICATING ANY MATERIAL.



ROAD NAME: CRUZLEY BLUFF ROAD	MARK THOMAS & CO	COUNTY OF HUMBOLDT DEPARTMENT OF PUBLIC WORKS	SHEET 28 OF 28
ROAD NO: 30100	MILE POST: 10.31		
PROJECT NO: WBLB-SR04(17)	EA NO: 000002	DESIGNED BY: JP	ROCK SLOPE PROTECTION
CONTRACT NO: 20-030	BN NO: 4C-258	DRAWN BY: GR	
DRAWING FILE NAME:	REVIEWED BY: JP		
PLT DATE: DECEMBER 2017	REVISION DATE: 02/01/2020	CHECKED BY: VE	

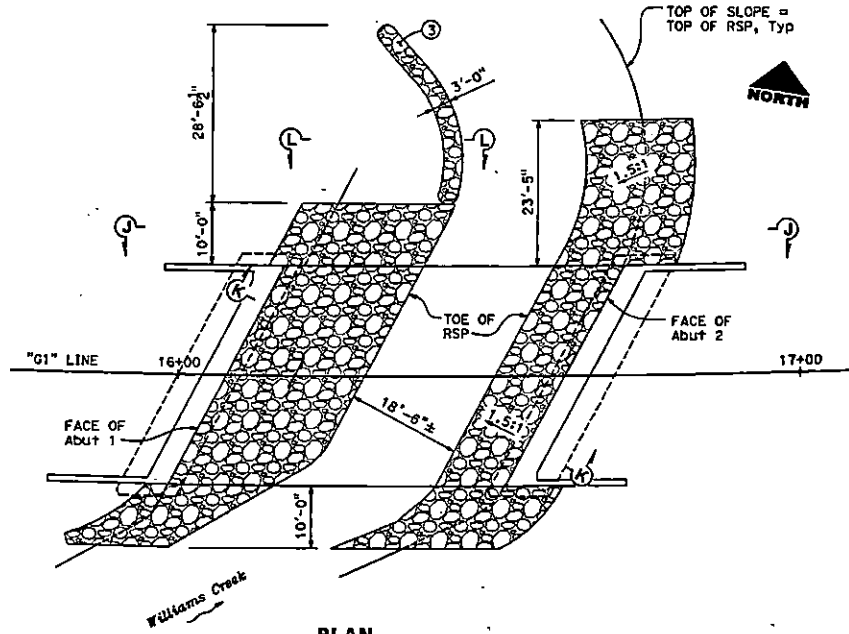

PLAN
NO SCALE

- LEGEND:
- ① Rock Slope Protection, 1/4 Ton (Method B)
 - ② Rock Slope Protection Backing No. 2 (Method B)
 - ③ Rock Slope Protection 1 Ton (Method A)
 - ④ Rock Slope Protection Fabric (Class 8)

NOTE:
THE CONTRACTOR SHALL VERIFY ALL
CONTROLLING FIELD DIMENSIONS BEFORE
ORDERING OR FABRICATING ANY MATERIAL.

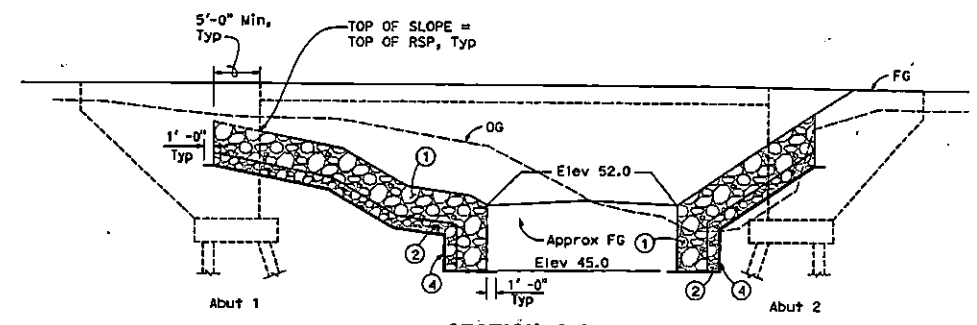

SECTION J-J
NO SCALE

- NOTES:
1. Bridge Rail not shown.
 2. Stop Rock Slope Protection Fabric 1 foot from edge of RSP limit.
- NOTE: For details not shown, see "SECTION K-K"

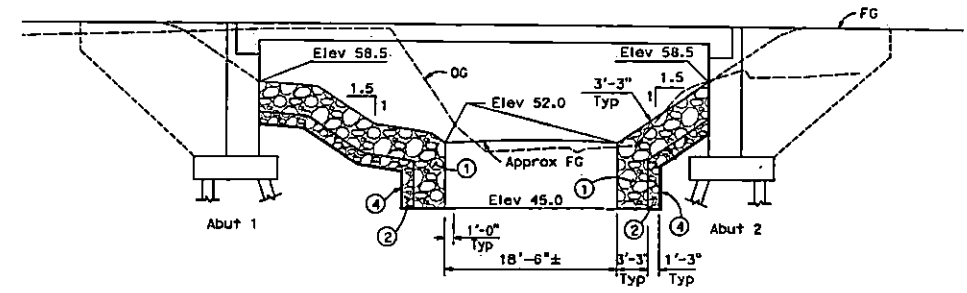

SECTION K-K
NO SCALE

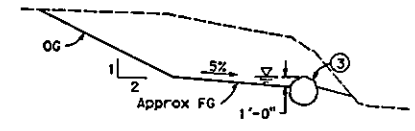

SECTION L-L
NO SCALE

W:\Projects\24-1111 Cruzley Bluff Bridge Replacement\2407\Drawings\Structure Details\28-Williams Creek Bridge (4C-258) 12/17/2017 2:35 PM

M.A.S.A.
REGISTERED CIVIL ENGINEER



ROAD NAME	GRIZZLY BLUFF ROAD	PROJECT NO.	0815-580(127)	DATE	09/23/2014
ROAD NO.	20100	CONTRACT NO.	284229	REVISED DATE	1/7/2017
FILE NO.	10 21	DESIGNED BY	BC	APPROVED BY	BC
DRWN BY	KL	CHECKED BY	BC		

100% SUBMITTA

- NOTES:
- Field classification of soils was in accordance with the California Soil & Rock Logging, Classification, and Presentation Manual (2010). See Log of Test Borings No. 5, Soil Legend.
 - Standard Penetration tests were performed using in accordance with ASTM D 1586 (using a hammer operated with an automated drop system). Drill rods were 1.68-inch diameter "C" code sampler was driven with brass fins.
 - 3/4 inch sampler ID = 2.4 inch, OD = 2.8 inch, 2.0 inch sampler ID = 2.0 inch, OD = 2.3 inch. Both often in same cover as GPT (1.4 inch) sampler.
 - If necessary tests are not shown as being performed, the soil descriptions presented in the LOGS are based solely on the visual practices described in the Manual.
 - The length of each sampled interval is shown graphically on the boring log. Whole number blow counts (N) represent the "standard penetration resistance" interval in accordance with the California Soil & Logging, Classification, and Presentation Manual (June 2010). Values less than 0.8 inches of penetration is achieved, the blow count shown is for that fraction of the "standard penetration resistance" interval actually penetrated.
 - Consistency of soils shown in () where estimated.
 - Ground water surface (GWS) elevations in the borings indicated on the Log of Test Borings Sheets reflect the field level in the borings on the specified date.
 - Ground water surface elevations are subject to seasonal fluctuations and may occur at higher or lower elevations depending on the conditions at any particular time.
 - The "Log of Test Borings" drawing is included with plans in accordance with Section 4-1.03 of California "Standard Specifications".

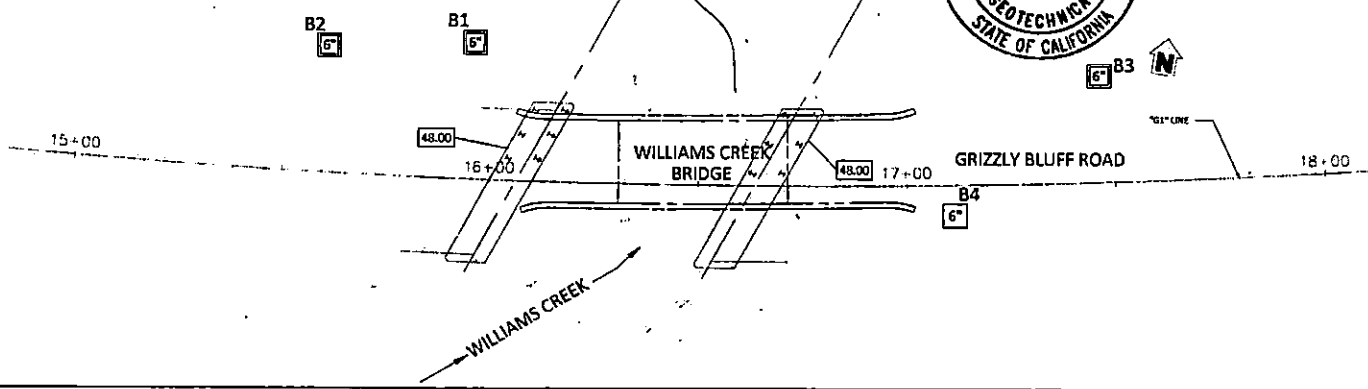

PLAN 1"=30'

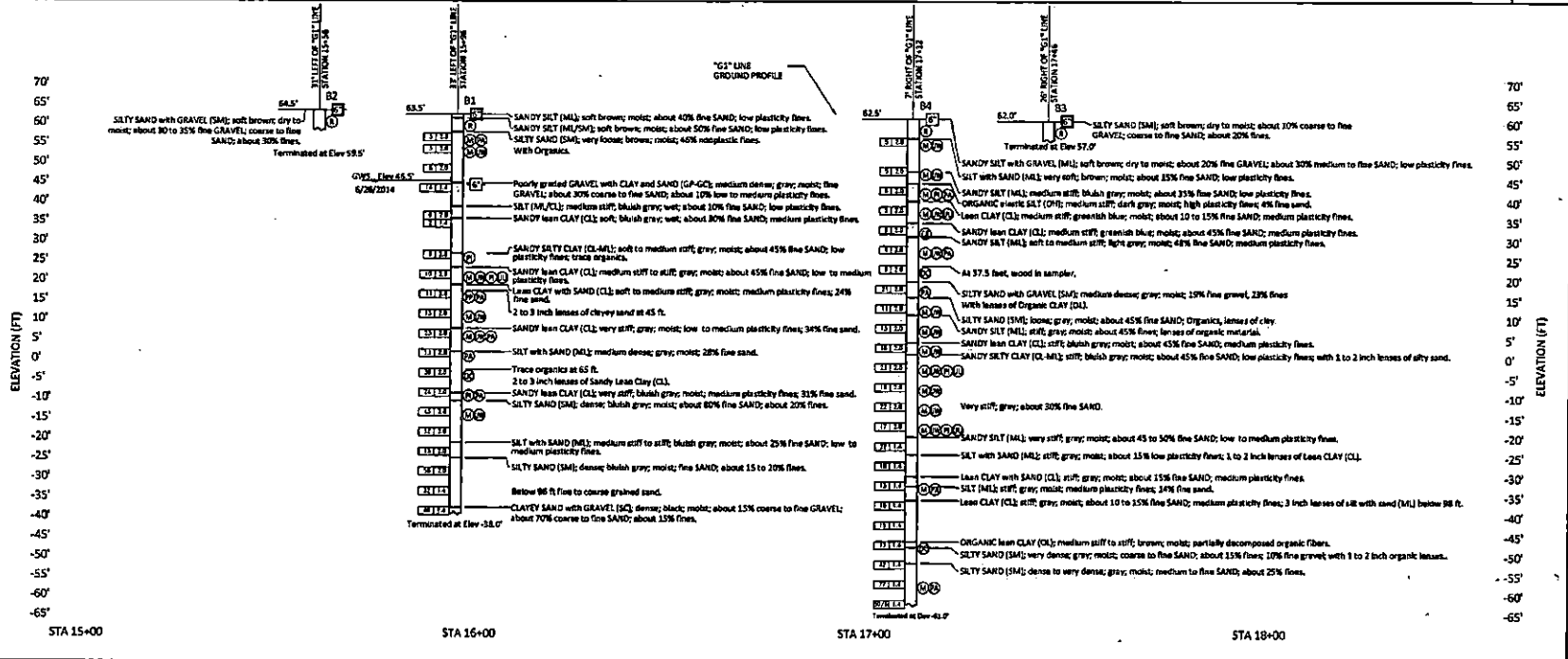

PROFILE 1"=30'

THIS LOGS WAS DEVELOPED IN ACCORDANCE WITH THE CALIFORNIA SOIL & ROCK LOGGING, CLASSIFICATION, AND PRESENTATION MANUAL (JUNE 2010)

1. John Sany (Project) 158-3 Group; Boring Sheet Range - Numbered(40) 1-158-1 (LOT) with the 8148 Reg. 1/20/2013 3:18 PM