



COUNTY OF HUMBOLDT

AGENDA ITEM NO.

For the meeting of: July 1, 2014

Date: June 11, 2014

To: Board of Supervisors

From: *Thomas K. Mattson*
Thomas K. Mattson, Director of Public Works

Subject: **REDWAY TRANSFER STATION REHABILITATION PROJECT,
CONTRACT NO. : 438002**

RECOMMENDATION(S):

That the Board of Supervisors:

- 1) Approve the attached plans and specifications for the Redway Transfer Station Rehabilitation Project,
- 2) Direct the Clerk to advertise the above-mentioned project as required by Section 22037 of the California Public Contract Code with bids to be opened on Tuesday, August 5, 2014 at 2:00 PM.

SOURCE OF FUNDING:

Solid Waste Fund - Redway Transfer Facility Maintenance (3691)

DISCUSSION:

This project will rehabilitate the pavement and drainage facilities at the Redway Transfer Station, which has been used for solid waste services since the 1970s. The property is leased from the State of California and operated by Eel River Disposal Company under a franchise agreement. The existing asphalt pavement will be removed and new aggregate base material installed with geosynthetic reinforcement. The existing

Prepared by Hank Seemann

CAO Approval

Chey Dillingham

REVIEW:

Auditor _____ County Council *SM* Personnel _____ Risk Manager _____ Other _____

TYPE OF ITEM:

- Consent
- Departmental
- Public Hearing
- Other _____

BOARD OF SUPERVISORS, COUNTY OF HUMBOLDT

Upon motion of Supervisor _____ Seconded by Supervisor _____

- Ayes
- Nays
- Abstain
- Absent

PREVIOUS ACTION/REFERRAL:

Board Order No. _____

Meeting of: _____

and carried by those members present, the Board hereby approves the recommended action contained in this Board report.

Dated: _____

By: _____

Kathy Hayes, Clerk of the Board

septic leach field will be decommissioned and the area surfaced with new asphalt paving. This will improve vehicle circulation and expand the equipment staging area. New french drains, drainage swales and asphalt dikes will be installed as well as other drainage, erosion, and pollutant control measures.

FINANCIAL IMPACT:

The requested action does not impact the General Fund, as 100% of the costs are funded through solid waste franchise fees. The Engineer's Estimate for the construction contract is \$344,880, with an additive option of \$38,520 for an additional 0.1-foot thickness of asphalt. Project costs are included in the Fiscal Year 2014/15 budget for Solid Waste (1100438-8998).

This project conforms to the Board of Supervisors' core role of providing for and maintaining infrastructure as identified in the Board's Strategic Framework.

OTHER AGENCY INVOLVEMENT:

California Department of Forestry and Fire Protection
County Division of Environmental Health

ALTERNATIVES TO STAFF RECOMMENDATIONS:

The Board could elect not to approve the project; however, the facility is highly used and the pavement is in poor condition. Rehabilitation of pavement has been recommended by the County Division of Environmental Health which is the solid waste local enforcement agency.

ATTACHMENTS:

County of Humboldt • Department of Public Works
1106 Second Street • Eureka • CA • 95501 • (707) 445-7652



SPECIAL PROVISIONS

NOTICE TO CONTRACTORS,
PROPOSAL AND CONTRACT

FOR

**REDWAY TRANSFER STATION
REHABILITATION PROJECT**

CONTRACT NO.: 438002

40 WORKING DAYS

FOR USE WITH Standard Specifications dated 2010,
Standard Plans dated 2010, Prevailing Wage Rates,
Labor Surcharge and Equipment Rental Rates

**BIDS OPEN :
AUGUST 5, 2014 AT 2:00 PM**

Clerk of the Board's Office
Humboldt County Courthouse
825 Fifth Street
Eureka, CA 95501

Updated 10/22/11 by LLH for 2010 Standard Spec's and Std Plans

DISCARD THIS PAGE

Variable Table			
Variable Description	Variable Name	Formula (hidden until right click and "toggle field codes" is selected)	Current Value
Bid Opening Date	BOD		August 5, 2014
Project Number	ProjNumber		PROJECT NO.:
Contract No.	ContractNo		CONTRACT NO.: 438002
Project Name	ProjName		REDWAY TRANSFER STATION REHABILITATION PROJECT
Working Days	WD		40
Engineer's Est.	EEst		\$344,880.00
Water Pollution Control	DSA		0.50 acres

Note:

The Cover Page needs to be updated separately.

SPECIAL PROVISIONS

**NOTICE TO CONTRACTORS
PROPOSAL AND CONTRACT**

FOR

**REDWAY TRANSFER STATION
REHABILITATION PROJECT
CONTRACT NO.: 438002**

Prepared by

**County of Humboldt
Department of Public Works
1106 Second Street
Eureka, CA 95501**

Approved:



Christopher J. Whitworth
RCE 51931, Expires 06/30/2016

6/11/2014
Date

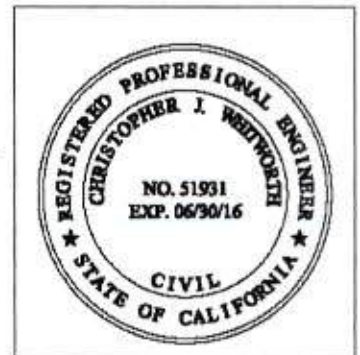

TABLE OF CONTENTS

NOTICE TO CONTRACTORS	2
SPECIAL PROVISIONS	5
DIVISION I GENERAL PROVISIONS	5
1 GENERAL.....	5
2 BIDDING.....	5
3 CONTRACT AWARD AND EXECUTION.....	6
5 CONTROL OF WORK.....	9
6 CONTROL OF MATERIALS.....	10
7 LEGAL RELATIONS AND RESPONSIBILITY TO THE PUBLIC.....	10
8 PROSECUTION AND PROGRESS.....	10
9 PAYMENT.....	11
DIVISION II GENERAL CONSTRUCTION	12
12 TEMPORARY TRAFFIC CONTROL.....	12
13 WATER POLLUTION CONTROL.....	13
15 EXISTING FACILITIES.....	13
15-2.02F REMOVE ASPHALT CONCRETE DIKES.....	13
DIVISION III GRADING	14
19 EARTHWORK.....	14
21 EROSION CONTROL.....	15
DIVISION IV SUB BASES AND BASES	16
26 AGGREGATE BASES.....	16
DIVISION V SURFACINGS AND PAVEMENTS	16
39 HOT MIX ASPHALT.....	16
DIVISION VI STRUCTURES	17
51 CONCRETE STRUCTURES.....	17
DIVISION VII DRAINAGE	17
68 SUBSURFACEDRAINS.....	17
71 RESERVED.....	18
DIVISION VIII MISCELLANEOUS CONSTRUCTION	18
73 CONCRETE CURBS AND SIDEWALKS.....	18
75 MISCELLANEOUS METAL.....	18
PROPOSAL	19
PROPOSAL SIGNATURE PAGE.....	22
BIDDER'S BOND.....	23
CONTRACTOR'S CERTIFICATE REGARDING WORKER'S COMPENSATION.....	24
LIST OF SUBCONTRACTORS.....	25
PUBLIC CONTRACT CODE SECTION 10285.1 STATEMENT.....	26
PUBLIC CONTRACT CODE SECTION 10162 QUESTIONNAIRE.....	26
PUBLIC CONTRACT CODE SECTION 10232 STATEMENT.....	26
DEBARMENT AND SUSPENSION CERTIFICATION.....	27
EQUAL EMPLOYMENT OPPORTUNITY CERTIFICATION.....	28
NONCOLLUSION AFFIDAVIT.....	29
SAMPLE FORMS	30
AGREEMENT.....	30
PAYMENT BOND.....	34
PERFORMANCE BOND.....	35



COUNTY OF HUMBOLDT
DEPARTMENT OF PUBLIC WORKS

NOTICE TO CONTRACTORS

Sealed proposals will be received by (and all bids should be mailed or delivered to) the

Clerk of the Board Office
SEALED BID for (Project Name)
Humboldt County Courthouse
825 Fifth Street
Eureka, California, 95501

until **2:00 PM, TUESDAY, August 5, 2014**, at which time they will be publicly opened by the Clerk of the Board of the County of Humboldt at a public meeting in the Office of the Clerk of the Board of Supervisors, Humboldt County Courthouse, Eureka, California, for performing work as follows:

**REDWAY TRANSFER STATION
REHABILITATION PROJECT
CONTRACT NO.: 438002**

Bids are required for the entire work as described herein:

This project will rehabilitate the pavement and drainage facilities at the Redway Transfer Station, which has been used for solid waste services since the 1970s. The property is leased from the state of California and operated by Eel River Disposal Company, Inc. under a franchise agreement. Site improvements include new French drains and drainage swales; roadway excavation; new and replacement asphalt dikes and parking bumpers; new aggregate base with geosynthetic reinforcement; and new asphalt paving. The existing septic leach field will be decommissioned to enable expansion of the paved area in front of the tipping bay, in order to improve circulation and expand the equipment staging area. Bidders are advised that the work must be completed within **40 working days**. The Engineer's Estimate for this work is: **\$344880.00**.

Plans, Special Provisions (not including documents included by reference) and Proposal Forms may be obtained by prospective Bidders upon **ADVANCE** payment of a non-refundable printing and service charge in the amount of **\$15.00**. All checks shall be made payable to COUNTY OF HUMBOLDT and should be mailed along with the request for Plans to the Humboldt County Department of Public Works, 1106 Second Street, Eureka, California, 95501.

Telephone: (707) 445-7652	Requests for plans, plan holder list or project estimate
(707) 445-7377	Engineering division, questions regarding plans or specs
(707) 445-7409	Fax transmissions

The successful Bidder shall furnish a Payment Bond and a Performance Bond.

The Contractor shall possess a **CLASS "A"** Contractors License at the time this contract is awarded.

This contract is subject to state contract nondiscrimination and compliance requirements pursuant to Government Code, Section 12990.

Pursuant to Section 1773 of the Labor Code, the general prevailing wage rates in the county, or counties, in which the work is to be done have been determined by the Director of the California Department of Industrial Relations. These wages are set forth in the General Prevailing Wage Rates for this project, available at County of Humboldt, 1106 2nd Street, Eureka, CA. 95501 and available from the California Department of Industrial Relations' Internet web site at <http://www.dir.ca.gov>.

KATHY HAYES

Clerk of the Board of Supervisors
County of Humboldt, State of California

DATED: _____

Standard Plans List

The standard plan sheets applicable to this Contract include those listed below. The applicable revised Standard Plans (RSP) listed below are included in the project plans.

ABBREVIATIONS, LINES, SYMBOLS AND LEGEND

A10A	ABBREVIATIONS (SHEET 1 OF 2)
A10B	ABBREVIATIONS (SHEET 2 OF 2)
A10C	LINES AND SYMBOLS (SHEET 1 OF 3)
A10D	LINES AND SYMBOLS (SHEET 2 OF 3)
A10E	LINES AND SYMBOLS (SHEET 3 OF 3)

CURBS, DRIVEWAYS, DIKES, CURB RAMPS AND ACCESSIBLE PARKING

	HOT MIX ASPHALT
A87B	DIKES

DRAINAGE INLETS, PIPE INLETS AND GRATES

D73	DRAINAGE INLETS
D73A	DRAINAGE INLETS (PRE-CAST)
D74B	DRAINAGE INLETS DRAINAGE INLET
D74C	DETAILS
D75C	PIPE INLETS (TRASH RACK DETAILS) GRATE
D77A	DETAILS
D78A	GUTTER DEPRESSIONS
D102	UNDER DRAIN DETAILS

TEMPORARY WATER POLLUTION CONTROL

T51	TEMPORARY WATER POLLUTION CONTROL (TEMP. SILT FENCE)
T53	TEMPORARY WATER POLLUTION CONTROL (TEMP. COVER)
T56	TEMPORARY WATER POLLUTION CONTROL (TEMP. FIBER ROLL)
T57	TEMPORARY WATER POLLUTION CONTROL (TEMP. CHECK DAMS)
T61	TEMPORARY WATER POLLUTION CONTROL (TEMP. DI INLET PROTECTION)
T62	TEMPORARY WATER POLLUTION CONTROL (TEMP. DI INLET PROTECTION)
T63	TEMPORARY WATER POLLUTION CONTROL (TEMP. DI INLET PROTECTION)



COUNTY OF HUMBOLDT
DEPARTMENT OF PUBLIC WORKS

**SPECIAL PROVISIONS
FOR**

**REDWAY TRANSFER STATION
REHABILITATION PROJECT**

CONTRACT NO.: 438002

DIVISION I GENERAL PROVISIONS

1 GENERAL

The work embraced herein shall be done in accordance with the **STANDARD SPECIFICATIONS dated 2010**, and the **STANDARD PLANS dated 2010**, of the State of California, Department of Transportation insofar as the same may apply and in accordance with the following special provisions. In case of conflict between the Standard Specifications and these special provisions, the special provisions shall take precedence over and be used in lieu of such conflicting portions.

Add to section 1-1.07A:

Whenever the following terms are used in the Standard Specifications, the following County departments or persons shall be intended and substituted therefore:

STATE : County of Humboldt, a political subdivision of the State of California.

DEPARTMENT , DIRECTOR : Humboldt County Department of Public Works.

ENGINEER : The Director of Public Works of Humboldt County or his authorized agent working within the scope of his authority.

LABORATORY : Materials and Testing Laboratory of the Humboldt County Department of Public Works.

2 BIDDING

Add to section 2-1.06A:

Plans, Special Provisions (not including documents included by reference) and Proposal Forms may be viewed by prospective Bidders at the Humboldt County Department of Public Works, 1106 Second Street, Eureka, California.

Any addenda or bulletins issued during the time of bidding, or forming a part of the documents issued to the Bidder for the preparation of his bid, shall be covered in the bid, and shall become a part of the Agreement.

No person, firm, or corporation shall be allowed to make or file, or be interested in, more than one bid for the same work, unless alternate bids are called for. A person, firm, or corporation who has submitted a subproposal to a Bidder, or who has quoted prices on materials to a Bidder, is not thereby disqualified from submitting a subproposal or quoting prices to other Bidders.

Replace section 3-1.05:

The successful Bidder, simultaneously with the execution of the Agreement, will be required to furnish a **Payment Bond** in an amount equal to **one hundred (100%) percent** of the contract price, and a faithful **Performance Bond** in an amount equal to **one hundred (100%)** of the contract price; said Bonds shall be secured from a surety company satisfactory to the Humboldt County Board of Supervisors. The Payment Bond shall comply with Section 3248 of the Civil Code of the State of California. The Payment Bond and the faithful Performance Bond shall each be in a form which is satisfactory to the County Counsel of the County of Humboldt. A copy of an acceptable format is attached to the Agreement forms included in the proposal section of these specifications.

Replace section 3-1.07:

I. THIS CONTRACT/AGREEMENT SHALL NOT BE EXECUTED BY COUNTY and the CONTRACTOR is not entitled to any rights, unless certificates of insurance, or other sufficient proof that the following provisions have been complied with, and such certificate(s) are filed with the Clerk of the Humboldt County Board of Supervisors.

II. Without limiting Contractor's indemnification provided herein, Contractor shall and shall require any of its subcontractors to take out and maintain, throughout the period of this Agreement, the following policies of insurance placed with insurers with a current A.M. Bests rating of no less than A:VII or its equivalent against injury/death to persons or damage to property which may arise from or in connection with the activities hereunder of Contractor, its agents, employees or subcontractors:

A. Comprehensive or Commercial General Liability Insurance at least as broad as Insurance Services Office Commercial General Liability coverage (occurrence from CG 0001), in an amount of \$1,000,000 per occurrence. If work involves explosive, underground or collapse risks, XCU must be included. If a general aggregate limit is used, either the general aggregate limit shall apply separately to this project or the general aggregate shall be twice the required occurrence limit. Said policy shall contain, or be endorsed with, the following provisions:

(1) The County, its officers, employees and agents, are covered as additional insured for liability arising out of the operations performed by or on behalf of Contractor. The coverage shall contain no special limitations on the scope of protection afforded to the County, its officers, agents, and employees.

(2) The policy shall not be canceled or materially reduced in coverage without thirty (30) days prior written notice (10 days for non-payment of the premium) to County by certified mail.

(3) The inclusion of more than one insured shall not operate to impair the rights of one insured against another insured, and the coverage afforded shall apply as though separate policies had been issued to each insured, but the inclusion of more than one insured shall not operate to increase the limits of the insurer's liability.

(4) For claims related to this project, the Contractor's insurance is primary coverage to the County, and any insurance or self-insurance programs maintained by the County are excess to Contractor's insurance and will not be called upon to contribute with it.

(5) Any failure to comply with reporting or other provisions of the parties, including breach of warranties, shall not affect coverage provided to County, its officers, employees, and agents.

B. Automobile liability insurance with coverage at least as broad as Insurance Services Office form CA 0001 06092, Code 1 (any auto), for vehicles used in the performance of this Agreement with minimum coverage of not less than \$1,000,000 per accident combined single limit (CSL). Such policy shall contain or be endorsed with the provision that coverage shall not be canceled or materially reduced in coverage without thirty(30) days prior written notice (10 days for non-payment of premium) to County by certified mail.

C. Workers' Compensation insurance meeting statutory limits of the California Labor Code which policy shall contain or be endorsed to contain a waiver of subrogation against County, its officers, agents, and employees and provide for thirty (30) days prior written notice in the event of cancellation.

D. Contractor shall furnish County with certificates and original endorsements effecting the required coverage prior to execution of this Agreement by County. The endorsements shall be on forms as approved by the County's Risk Manager or County Counsel. Any deductible or self-insured retention over \$100,000 shall be disclosed to and approved by County. If Contractor does not keep all required policies in full force and effect, County may, in addition to other remedies under this Agreement, take out the necessary insurance, and Contractor agrees to pay the cost of said insurance.

The County may elect to treat a failure to maintain the requisite insurances as a breach of contract/agreement and terminate the contract/agreement as provided herein.

III. Contractor shall indemnify and hold harmless County and its Board, officers, officials, employees, and volunteers from and against all claims, damages, losses, and expenses including attorney fees arising out of the performance of the work described herein, caused in whole or in part by any negligent act or omission by the contractor, any subcontractor, anyone directly or indirectly employed by any of them or anyone for whose acts any of them may be liable, except where caused by the active negligence, sole negligence, or willful misconduct of the County.

Replace paragraph 4, section 3-1.18:

The form of Agreement which the successful Bidder, as Contractor, will be required to execute, is included in the contract documents and should be carefully examined by the bidder. The agreement and bonds will be executed in duplicate. The signed agreements and bonds together with the required insurance certificates are to be returned by the successful bidder within **7 days**, not including Sundays and legal holidays, after the bidder has received the contract for execution.

AA

5 CONTROL OF WORK

Add to section 5-1.13A:

The subcontractors listed on the "Subcontractor List," shall perform the work and supply the materials for which they are listed, unless the Contractor has received prior written authorization to perform the work with other forces or to obtain the materials from other sources.

The Contractor should notify the Engineer in writing of any changes to its anticipated subcontractor participation. This notice should be provided prior to the commencement of that portion of the work.

Per Govt Code § 4216 et seq., the Contractor shall notify the Engineer and the appropriate regional notification center for operators of subsurface installations at least 3 working days, but not more than 14 calendar days, prior to performing any excavation or other work close to any underground pipeline, conduit, duct, wire or other structure. Regional notification centers include but are not limited to the following:

Notification Center	Telephone Number
Underground Service Alert-Northern California (USA)	1-800-642-2444 1-800-227-2600
Underground Service Alert-Southern California (USA)	1-800-422-4133 1-800-227-2600

Add to section 5-1.20:

Coordination with Eel River Disposal (ERD) during the project to minimize delays of patrons dumping garbage is essential to the project.

ERD hours are as follows:

- Mon/Tue: 9:00-4:00 (public)
- Wed/Thu: 9:00-1:30 (open to accounts only)
- Fri/Sat: 9:00-4:00 (public)
- Sun: 12:00-4:00 (public)

Paving and excavation of areas in front of the garbage bay will need to be done at a time when no patrons are there.

AA

6 CONTROL OF MATERIALS

Add to section 6-2.03:

The Contractor shall notify the Engineer not less than 48 hours before County-furnished material is to be picked up by the Contractor. A full description of the material and the time the material will be picked up shall be provided.

AA

7 LEGAL RELATIONS AND RESPONSIBILITY TO THE PUBLIC

Add to section 7-1.02K(2) paragraph 2:

The general prevailing wage rates determined by the Director of Industrial Relations, for the county or counties in which the work is to be done, are available at the Humboldt County Department of Public Works, 1106 Second Street, Eureka CA 95501. These wage rates are not included in the Special Provision, Notice to Bidder's, Proposal and Contract Book for the project. Changes, if any, to the general prevailing wage rates will be available at the same location.

Add to section 7-1.02L:

7-1.02L(3) Noncollusion

In conformance with Public Contract Code Section 7106, a Noncollusion Affidavit is included in the Proposal. Signing the Proposal shall also constitute signature of the Noncollusion Affidavit.

Add to section 7-1.02M(3):

Material from mining operations furnished for this project shall only come from sites in compliance with the Surface Mining and Reclamation Act of 1975 (SMARA) or sites not subject to SMARA. Contractor shall provide County with documentation establishing compliance with SMARA or exemption from SMARA.

The requirements of this section shall apply to materials furnished for the project, except for acquisition of materials in conformance with the provisions in section 4-1.04, "Use of Materials Found on the Job Site," of the Standard Specifications.

AA

8 PROSECUTION AND PROGRESS

Replace section 8-1.04B, paragraph 1:

The Contractor shall begin work within fifteen calendar days after the contract has been executed by the Board of Supervisors of the County of Humboldt, provided he has received a written "Notice to Proceed" from the Engineer in accordance with Section 4 of the contract Agreement.

Replace section 8-1.05, paragraph 2:

Said work shall be diligently prosecuted to completion before the expiration of: **40 WORKING DAYS**

Tabulation of working days shall begin on the fifteenth calendar day after execution of the contract by the Board of Supervisors of the County of Humboldt. If said fifteenth calendar day falls on a Saturday,

AA

13 WATER POLLUTION CONTROL

Insert into Section 13-1.01:

Preliminary calculations by the Engineer indicate that the project's disturbed soil area is 0.50 acres not including borrow site or Contractor's staging area.

AA

15 EXISTING FACILITIES

15-2.02B(3)(c)(i) General

Do not use a heating device to soften the pavement.

The cold planing machine must be:

1. Equipped with a cutter head width that matches the planing width. If the cutter head width is wider than the cold plane area shown, submit to the Engineer a request for using a wider cutter head. Do not cold plane unless the Engineer approves your request.
2. Equipped with automatic controls for the longitudinal grade and transverse slope of the cutter head and:
 - 2.1. If a ski device is used, it must be at least 30 feet long, rigid, and a 1-piece unit. The entire length must be used in activating the sensor.
 - 2.2. If referencing from existing pavement, the cold planing machine must be controlled by a self-contained grade reference system. The system must be used at or near the centerline of the roadway. On the adjacent pass with the cold planing machine, a joint-matching shoe may be used.
3. Equipped to effectively control dust generated by the planing operation
4. Operated so that no fumes or smoke is produced.

Replace broken, missing, or worn machine teeth.

15-2.02F Remove Asphalt Concrete Dikes

All removed AC Dike shall become property of the Contractor and shall be disposed of outside the project are in accordance with the provisions in Section 5-1.20B(4) of the Standard Specifications.

15-2.02B(4) Remove Subbase, Base, and Bituminous Surfacing

Remove the subbase, base, and bituminous surfacing to a depth of at least 6 inches below the grade of the existing surfacing. Subbases and bases include the various types shown. Backfill the resulting holes and depressions with earth material from the excavation and to the lines and grades established by the Engineer.

AA

DIVISION III GRADING

19 EARTHWORK

Add to Section 19-1.01A:

Earthwork activities include clearing and grubbing, developing a water supply, and finishing the roadway. Comply with sections 16, 17-2, and 22.

Replace paragraphs 3 and 4 of Section 19-2.03B with:

Surplus excavated material shall become the property of the Contractor and shall be disposed of outside the project area in accordance with the provisions in Section 5-1.20B(4) of the Standard Specifications.

Add to Section 19-2.03G :

Slopes above the French drains shall be graded at a 2:1 or less with placement of fiber rolls as shown on the plans. The slopes shall be hydroseeded after placement of fiber rolls.

Add to Section 19-6.02B:

Geosynthetic soil reinforcement for use in the aggregate base layer under the HMA overlay, shall be Tensar BX 1200 or approved equal. The Geogrid must be placed as shown on the plans, in accordance with the manufacturer's instructions and as directed by the Engineer.

AA

21 EROSION CONTROL

Add to Section 21-1.02L:

Hydroseed work shall consist of applying erosion control materials, consisting of a mixture of fiber, seed, tackifier, commercial fertilizer and water. The mixture shall be applied to embankment and excavation slopes and other graded or disturbed areas of the project including any borrow or disposal sites as determined by the Engineer.

Seed shall consist of the following native species or equivalent approved by Engineer:

<u>Botanical Name (Common Name)</u>	<u>Percentage Purity (minimum)</u>	<u>Percentage Germination (minimum)</u>	<u>Lbs. Per Acre</u>
Bromus Carinatus (California Brome)	95	95	35
Vulpia microstachys (Small Fescue or Three Weeks Fescue)	98	85	6
Trifolium wildenovii (Tomcat Clover)	98	80	4

Seed shall be mixed on the project site in the presence of the Engineer.

The erosion control materials shall be mixed and applied in the following proportions:

<u>Material</u>	<u>Lbs. per Acre (Slope Measurement)</u>
Fiber	1500
Seed	45
Commercial Fertilizer	300

Tackifier conforming to section 21-1.02F shall be incorporated in the mix at the rate recommended by the manufacturer.

Hydroseed will be paid for as a lump sum payment which shall include full compensation for furnishing all materials, equipment, tools, etc, and for doing all work involved in completing the hydroseeding work as specified herein and as directed by the Engineer.

Per section 21-2.02P:

21-1.02P Fiber Rolls

Fiber roll must have a minimum functional longevity of 1 year and comply with the following requirements:

AA

DIVISION VI STRUCTURES

51 CONCRETE STRUCTURES

Section 51-7.02 PRECAST DRAINAGE INLETS

Replace "Reserved" with

Pre-cast Drainage inlets shall be installed in compliance with Section 90 Concrete. Install pre-cast Drainage inlets as shown on plans and directed by the Engineer. Contractor shall install a county-furnished trash guard inside inlets. These can be installed after placement of the DI.

AA

DIVISION VII DRAINAGE

68 SUBSURFACEDRAINS

Per section 68-2.02f

68-2.02F Permeable Material

68-2.02F(1) General

Permeable material for use in backfilling trenches under, around, and over underdrains must consist of hard, durable, clean sand, gravel, or crushed stone and must be free from organic material, clay balls, or other deleterious substances.

Permeable material must have a durability index of not less than 40.

68-2.02F(3) Class 2 Permeable Material

The percentage composition by weight of Class 2 permeable material in place must comply with the grading requirements shown in the following table:

**Class 2 Permeable Material
Grading Requirements**

Sieve sizes	Percentage passing
1"	100
3/4"	90-100
3/8"	40-100
No. 4	25-40
No. 8	18-33
No. 30	5-15
No. 50	0-7
No. 200	0-3

Class 2 permeable material must have a sand equivalent value of not less than 75.

71 RESERVED

Section 71 replace "Reserved" with

71 DRAINAGE INSERTS

Drainage inlet inserts shall be either PIG Quick-Fit Drain Insert (#FLT745) for oil and sediment filtering or equivalent. Equivalent measures must be presented to the Engineer and approved by the Engineer prior to purchase and installation. Submittals of equivalent measures must be in writing and include manufacturer's specifications. The oil and sediment filter must fit into the 10X10 Drainage Inlets. They must be installed as per manufactures' specifications and instructions.

^^

DIVISION VIII MISCELLANEOUS CONSTRUCTION

73 CONCRETE CURBS AND SIDEWALKS

Section 73-5 replace "Reserved" with:

73-5 Pre-Cast Parking Bumpers

Pre-cast parking bumpers shall be installed at locations as shown on the plans. The bumpers shall be anchored to the new pavement using #5 rebar.

^^

75 MISCELLANEOUS METAL

Per section 75-1.02B

Grates must be produced from one of the following:

1. Structural steel complying with one of the following:
 ASTM A 36/A 36M
 A576, GRADES 1021, 1022, 1026, 1029, OR 1030
2. DUCTILE IRON CASTINGS
3. CARBON-STEEL CASTINGS

Match-mark frames and grates and covers in pairs before delivery to the job site; the grates and covers must fit into their frames without rocking.

^^

PROPOSAL
TO
THE COUNTY OF HUMBOLDT
FOR

**REDWAY TRANSFER STATION
REHABILITATION PROJECT**

CONTRACT NO.: 438002

Name of Bidder: _____
(Name must be exactly as it appears [or will appear] on Contractor's license)

Business
Address: _____

Telephone No.: _____

Place of Residence: _____

The work for which this proposal is submitted is for construction in accordance with the special provisions (including the payment of not less than the State general prevailing wage rates or Federal minimum wage rates), the project plans, including any addenda thereto, the contract annexed hereto and also in accordance with the California Department of Transportation Standard Plans, dated **2010**, the Standard Specifications, dated **2010**, and the Labor Surcharge and Equipment Rental Rates in effect at the time the work is performed.

Bids are to be submitted for the entire work. **The amount of the bid for comparison purposes will be the total of all Base Bid items or the total of Base Bid plus Additive(s) if the Additive(s) is awarded.**

The bidder shall set forth for each unit basis item of work a unit price and a total for the item, and for each lump sum item a total for the item, all in clearly legible figures in the respective spaces provided for that purpose. In the case of unit basis items, the amount set forth under the "Item Total" column shall be the product of the unit price bid and the estimated quantity for the item.

In case of discrepancy between the unit price and the total set forth for a unit basis item, the unit price shall prevail, except as provided in (a) or (b), as follows:

- (a) If the amount set forth as a unit price is unreadable or otherwise unclear, or is omitted, or is the same as the amount as the entry in the item total column, then the amount set forth in the item total column for the item shall prevail and shall be divided by the estimated quantity for the item and the price thus obtained shall be the unit price;
- (b) (Decimal Errors) If the product of the entered unit price and the estimated quantity is exactly off by a factor of ten, one hundred, etc., or one-tenth, or one-hundredth, etc. from the entered total, the discrepancy will be resolved by using the entered unit price or item total, whichever most closely approximates percentagewise the unit price or item total in the County of Humboldt's Final Estimate of cost.

If both the unit price and the item total are unreadable or otherwise unclear, or are omitted, the bid may be deemed irregular. Likewise if the item total for a lump sum item is unreadable or otherwise unclear, or is omitted, the bid may be deemed irregular unless the project being bid has only a single item and a clear, readable total bid is provided.

Symbols such as commas and dollar signs will be ignored and have no mathematical significance in establishing any unit price or item total or lump sums. Written unit prices, item totals and lump sums will be interpreted according to the number of digits and, if applicable, decimal placement. Cents symbols also have no significance in establishing any unit price or item total since all figures are assumed to be expressed in dollars and/or decimal fractions of a dollar. Bids on lump sum items shall be item totals only; if any unit price for a lump sum item is included in a bid and it differs from the item total, the items total shall prevail.

The foregoing provisions for the resolution of specific irregularities cannot be so comprehensive as to cover every omission, inconsistency, error or other irregularity which may occur in a bid. Any situation not specifically provided for will be determined in the discretion of the County of Humboldt, and that discretion will be exercised in the manner deemed by the County of Humboldt to best protect the public interest in the prompt and economical completion of the work. The decision of the County of Humboldt respecting the amount of a bid, or the existence or treatment of an irregularity in a bid, shall be final.

If this proposal shall be accepted and the undersigned shall fail to enter into the contract and furnish the 2 bonds in the sums required by the State Contract Act, with surety satisfactory to the County of Humboldt, within 8 days, not including Saturdays, Sundays and legal holidays, after the bidder has received notice from the County of Humboldt that the contract has been awarded, the County of Humboldt may, at its option, determine that the bidder has abandoned the contract, and thereupon this proposal and the acceptance thereof shall be null and void and the forfeiture of the security accompanying this proposal shall operate and the same shall be the property of the County of Humboldt.

The undersigned, as bidder, declares that the only persons or parties interested in this proposal as principals are those named herein; that this proposal is made without collusion with any other person, firm, or corporation; that he has carefully examined the location of the proposed work, the annexed proposed form of contract, and the plans therein referred to; and he proposes, and agrees if this proposal is accepted, that he will contract with the County of Humboldt, in the form of the copy of the contract annexed hereto, to provide all necessary machinery, tools, apparatus and other means of construction, and to do all the work and furnish all the materials specified in the contract, in the manner and time therein prescribed, and according to the requirements of the Engineer as therein set forth, and that he will take in full payment therefore the following prices, to wit:

REDWAY TRANSFER STATION REHABILITATION PROJECT

CONTRACT NO.: 438002

BID FORM

BASE BID

ITEM NO.	ITEM CODE	ITEM DESCRIPTION	UNIT	QTY	UNIT PRICE	TOTAL
1	130100	Job Site Management	LS	1		
2	130200	Prepare Water Pollution Control Program	LS	1		
3	130610	Temporary Check Dam	EA	4		
4	130620	Temporary Drainage Inlet Protection	EA	2		
5	150244	S Abandon Septic (Existing)	LS	1		
6	150771	Remove Asphalt Concrete Dike	LF	900		
7	150770	Remove Asphalt Concrete Pavement	SF	3,160		
9	198250	Geosynthetic Reinforcement	SY	3,164		
10	210350	Fiber Rolls	EA	45		
11	210430	Hydroseed	SF	9,117		
12	260203	Class 2 Aggregate Base (CY)	CY	685		
13	390132	Hot Mix Asphalt (Type A) (02)	Ton	586		
14	394073	Place Hot Mix Asphalt Dike (Type A)	LF	1,106		
15	517002	Furnish and Place Pre-cast DI	EA	2		
16	680285	4" Plastic Pipe Underdrain	LF	540		
17	682001	Permeable Material- Class 2	CY	100		
18	730045	Minor Structural Concrete- drainage swale	CY	9		
19	735000	Pre-cast parking bumpers (4')	EA	30		
20	750007	Grate for long drain	LS	1		
21		Pig Drain Inserts (oil, sediment and trash collectors)	EA	3		
22	999990	Mobilization	LS	1		
BASE BID TOTAL						

ADDITIVE OPTION A:

A1	390132	Hot Mix Asphalt (Type A) (.1)	Ton	214		
ADDITIVE BID TOTAL						

ACKNOWLEDGEMENT OF ADDENDA

<u>ADDENDUM NO.</u>	<u>INITIAL</u>
_____	_____
_____	_____
_____	_____

(Bidder's Signature)

(Title)

PROPOSAL SIGNATURE PAGE

Accompanying this proposal is _____

(NOTICE: INSERT THE WORDS "CASH (\$___)", "CASHIER'S CHECK", "CERTIFIED CHECK", OR "BIDDERS'S BOND", AS THE CASE MAY BE.)

in the amount of at least **TEN PERCENT (10%)** of the total bid.

The names of all persons interested in the foregoing proposal as Principals are as follows:

(NOTE: If a Bidder or other interested person is a Corporation, state the legal name of the corporation, also names of the president, secretary, treasurer, and manager thereof; if a Co-partnership, state the true name of the firm, also state the names of all individual copartners composing the firm; if the Bidder or other interested person is an Individual, state the first and last names in full.)

Licensed in accordance with an act providing for the registration of Contractors,

LICENSE NO. _____ **Classification(s)** _____

Note: It is optional to provide your contractors license number at this time. You are not required to provide your contractors license number until the time that the contract is to be awarded.

By my signature on this proposal I certify, under penalty of perjury under the laws of the State of California, that the foregoing questionnaire and statements of Public Contract Code Sections 10162, 10232 and 10285.1 are true and correct and that the bidder has complied with the requirements of Section 8103 of the Fair Employment and Housing Commission Regulations (Chapter 5, Title 2 of the California Administrative Code). By my signature on this proposal I further certify, under penalty of perjury under the laws of the State of California and the United States of America, that the Noncollusion Affidavit required by Title 23 United States Code, Section 112 and Public Contract Code Section 7106; and the Title 49 Code of Federal Regulations, Part 29 Debarment and Suspension Certification are true and correct.

Date: _____



Signature and Title of Bidder

Bidder's Business Address _____

Place of Residence _____

BIDDER'S BOND
COUNTY OF HUMBOLDT, DEPARTMENT OF PUBLIC WORKS
REDWAY TRANSFER STATION
REHABILITATION PROJECT

CONTRACT NO.: 438002

for which bids are to be opened on **TUESDAY**, August 5, 2014, at 2:00 PM, in the Office of the Clerk of the Board, Humboldt County Courthouse, in Eureka, California.

Know all men by these presents: That we _____

_____, as **PRINCIPAL**,

and _____,

as **SURETY**, are held and firmly bound unto the County of Humboldt in the penal sum of **TEN PERCENT (10%) OF THE TOTAL AMOUNT OF THE BID** of the **PRINCIPAL** named above, submitted by said **PRINCIPAL** to the County of Humboldt for the work described above, for the payment of which sum is lawful money of the United States, well and truly to be made, to the Director of the Department to which said bid was submitted, we bind ourselves, our heirs, executors, administrators and successors, jointly and severally, firmly by these presents. In no case shall the liability of the **SURETY** hereunder exceed the sum of:

\$ _____

THE CONDITION OF THIS OBLIGATION IS SUCH, that whereas the **PRINCIPAL** has submitted the above mentioned bid to the County of Humboldt, as aforesaid, for the construction as specifically described above,

NOW, THEREFORE, if the aforesaid **PRINCIPAL** is awarded the contract, and within the time and manner required under the Specifications, after the prescribed forms are presented to him for signature, enters into a written contract, in the prescribed form, in accordance with the bid, and files two bonds with the Department, one to guarantee faithful performance and the other to guarantee payment for labor and materials, as required by law, then this obligation shall be null and void; otherwise, it shall be and remain in full force and virtue.

IN WITNESS WHEREOF, we have hereunto set our hands and seals on this

_____ day of _____, 20_____.

_____(seal)

_____(seal)

PRINCIPAL

_____(seal)

_____(seal)

SURETY

Address: _____

Note: Signatures of those executing for **SURETY** must be properly acknowledged.

CONTRACTOR'S CERTIFICATE REGARDING WORKER'S COMPENSATION

Labor Code Section 3700.

"Every employer except the State and all political subdivisions or institutions thereof, shall secure the payment of compensation in one or more of the foregoing ways:

- A. By being insured against liability to pay compensation by one or more insurers duly authorized to write compensation insurance in this State.
- B. By securing from the Director of Industrial Relations a certificate of consent of self-insure, which may be given upon furnishing proof satisfactory to the Director of Industrial Relations of ability to self-insure and to pay any compensation that may become due to his employees."

I am aware of the provisions of Section 3700 of the Labor Code which requires every employer to be insured against liability for worker's compensation or to undertake self-insurance in accordance with the provisions of that code, and that I will comply with such provisions before commencing the performance of the work of this contract.

(In accordance with Article 5 [commencing at Section 1860], Chapter 1 , Part 7 , Division 2 , of the Labor Code, the above certificate must be signed and filed with the awarding body prior to commencing any work under this contract.)

LIST OF SUBCONTRACTORS

CONTRACT NO.: 438002

The bidder shall list all subcontractors in accordance with Section 2-1.054 of the Standard Specifications. Photocopy this form for additional firms.

Firm Name/ Address/ City, State, ZIP		Phone/ Fax	Interested in Bidding on:	Description of Portion of Work to be Performed
<i>Name</i>		<i>Phone</i>	Airport (FAA) funded work: <input type="checkbox"/> YES <input type="checkbox"/> NO	
<i>Address</i>				
<i>City State ZIP</i>		<i>Fax</i>	Highway (FHWA) funded work: <input type="checkbox"/> YES <input type="checkbox"/> NO	
<i>Name</i>		<i>Phone</i>	Airport (FAA) funded work: <input type="checkbox"/> YES <input type="checkbox"/> NO	
<i>Address</i>				
<i>City State ZIP</i>		<i>Fax</i>	Highway (FHWA) funded work: <input type="checkbox"/> YES <input type="checkbox"/> NO	
<i>Name</i>		<i>Phone</i>	Airport (FAA) funded work: <input type="checkbox"/> YES <input type="checkbox"/> NO	
<i>Address</i>				
<i>City State ZIP</i>		<i>Fax</i>	Highway (FHWA) funded work: <input type="checkbox"/> YES <input type="checkbox"/> NO	
<i>Name</i>		<i>Phone</i>	Airport (FAA) funded work: <input type="checkbox"/> YES <input type="checkbox"/> NO	
<i>Address</i>				
<i>City State ZIP</i>		<i>Fax</i>	Highway (FHWA) funded work: <input type="checkbox"/> YES <input type="checkbox"/> NO	

PUBLIC CONTRACT CODE SECTION 10285.1 STATEMENT

In conformance with Public Contract Code Section 10285.1 (Chapter 376, Stats. 1985), the bidder hereby declares under penalty of perjury under the laws of the State of California that the bidder has ____, has not ____ been convicted within the preceding three years of any offenses referred to in that section, including any charge of fraud, bribery, collusion, conspiracy, or any other act in violation of any state or Federal antitrust law in connection with the bidding upon, award of, or performance of, any public works contract, as defined in Public Contract Code Section 1101, with any public entity, as defined in Public Contract Code Section 1100, including the Regents of the University of California or the Trustees of the California State University. The term "bidder" is understood to include any partner, member, officer, director, responsible managing officer, or responsible managing employee thereof, as referred to in Section 10285.1.

Note: The bidder must place a check mark after "has" or "has not" in one of the blank spaces provided. The above Statement is part of the Proposal. Signing this Proposal on the signature portion thereof shall also constitute signature of this Statement. Bidders are cautioned that making a false certification may subject the certifier to criminal prosecution.

PUBLIC CONTRACT CODE SECTION 10162 QUESTIONNAIRE

Has the bidder, any officer of the bidder, or any employee of the bidder who has a proprietary interest in the bidder, ever been disqualified, removed, or otherwise prevented from bidding on, or completing a Federal, State or local government project because of a violation of law or a safety regulation?

YES NO

If the answer is yes, explain the circumstances in the following space.

PUBLIC CONTRACT CODE SECTION 10232 STATEMENT

In accordance with Public Contract Code Section 10232, the Contractor, hereby states under penalty of perjury, that no more than one final unappealable finding of contempt of court by a Federal court has been issued against the Contractor within the immediately preceding two year period because of the Contractor's failure to comply with an order of a Federal court which orders the Contractor to comply with an order of the National Labor Relations Board.

NOTE : The above statement and questionnaire constitute part of the Proposal, and signature on the signature portion of this Proposal shall constitute signature of this statement and questionnaire.

DEBARMENT AND SUSPENSION CERTIFICATION

TITLE 49, CODE OF FEDERAL REGULATIONS, PART 29

The bidder, under penalty of perjury, certifies that, except as noted below, he/she or any other person associated therewith in the capacity of owner, partner, director, officer, manager:

- is not currently under suspension, debarment, voluntary exclusion, or determination of ineligibility by any Federal agency;
- has not been suspended, debarred, voluntarily excluded or determined ineligible by any Federal agency within the past 3 years;
- does not have a proposed debarment pending; and
- has not been indicted, convicted, or had a civil judgment rendered against it by a court of competent jurisdiction in any matter involving fraud or official misconduct within the past 3 years.

If there are any exceptions to this certification, insert the exceptions in the following space.

Exceptions will not necessarily result in denial of award, but will be considered in determining bidder responsibility. For any exception noted above, indicate below to whom it applies, initiating agency, and dates of action.

Notes: Providing false information may result in criminal prosecution or administrative sanctions. The above certification is part of the Proposal. Signing this Proposal on the signature portion thereof shall also constitute signature of this Certification.

(THE BIDDER'S EXECUTION ON THE SIGNATURE PORTION OF THIS PROPOSAL SHALL ALSO CONSTITUTE AN ENDORSEMENT AND EXECUTION OF THOSE CERTIFICATIONS WHICH ARE A PART OF THIS PROPOSAL)

EQUAL EMPLOYMENT OPPORTUNITY CERTIFICATION

The bidder _____, proposed subcontractor _____, hereby certifies that he has _____, has not _____, participated in a previous contract or subcontract subject to the equal opportunity clauses, as required by Executive Orders 10925, 11114, or 11246, and that, where required, he has filed with the Joint Reporting Committee, the Director of the Office of Federal Contract Compliance, a Federal Government contracting or administering agency, or the former President's Committee on Equal Employment Opportunity, all reports due under the applicable filing requirements.

Note: The above certification is required by the Equal Employment Opportunity Regulations of the Secretary of Labor (41 CFR 60-1.7(b)(1)), and must be submitted by bidders and proposed subcontractors only in connection with contracts and subcontracts which are subject to the equal opportunity clause. Contracts and subcontracts which are exempt from the equal opportunity clause are set forth in 41 CFR 60-1.5. (Generally only contracts or subcontracts of \$10,000 or under are exempt.)

Currently, Standard Form 100 (EEO-1) is the only report required by the Executive Orders or their implementing regulations.

Proposed prime contractors and subcontractors who have participated in a previous contract or subcontract subject to the Executive Orders and have not filed the required reports should note that 41 CFR 60-1.7(b)(1) prevents the award of contracts and subcontracts unless such contractor submits a report covering the delinquent period or such other period specified by the Federal Highway Administration or by the Director, Office of Federal Contract Compliance, U.S. Department of Labor.

NONCOLLUSION AFFIDAVIT
(Title 23 United States Code Section 112 and
Public Contract Code Section 7106)

To the COUNTY OF HUMBOLDT, DEPARTMENT OF PUBLIC WORKS:

In accordance with Title 23 United States Code Section 112 and Public Contract Code 7106 the bidder declares that the bid is not made in the interest of, or on behalf of any undisclosed person, partnership, company, association, organization, or corporation; that the bid is genuine and not collusive or sham; that the bidder has not directly or indirectly induced or solicited any other bidder to put in a false or sham bid, and has not directly or indirectly colluded, conspired, connived, or agreed with any bidder or anyone else to put in a sham bid, or that anyone shall refrain from bidding; that the bidder has nor in any manner, directly or indirectly, sought by agreement, communication, or conference with anyone to fix the bid price of the bidder or any other bidder, or to fix any overhead, profit, or cost element of the bid price, or of that of any other bidder, or to secure any advantage against the public body awarding the contract or anyone interested in the proposed contract; that all statements contained in the bid are true; and, further, that the bidder has not, directly or indirectly, submitted his or her bid price or any breakdown thereof, or the contents thereof, or divulged information or data relative thereto, or paid, and will not pay, any fee to any corporation, partnership, company, association, organization, bid depository, or to any member or agent thereof to effectuate a collusive or sham bid.

NOTE : The above Noncollusion Affidavit is part of the Proposal. Signing this Proposal on the signature portion thereof shall also constitute signature of this Noncollusion Affidavit.

Bidders are cautioned that making a false certification may subject the certifier to criminal prosecution.

**SAMPLE FORMS
AGREEMENT**

This is an AGREEMENT made and entered into this _____ day
of _____, 20____, by and between the County of Humboldt, a
political subdivision of the State of California (hereinafter referred to as COUNTY)
and _____,
a corporation organized and existing under the laws of the State of _____;
a partnership consisting of _____

an individual doing business as _____
_____ in the State of California,
hereinafter referred to as "CONTRACTOR".

County and Contractor for the consideration hereinafter named agree as follows:

Section 1 - SCOPE OF WORK

Contractor shall furnish all Labor, Tools and Materials and perform all the work for the:

**REDWAY TRANSFER STATION
REHABILITATION PROJECT
CONTRACT NO.: 438002**

in accordance with the contract documents referred to in Section 3 of this Agreement.

Section 2 - CONTRACT PRICE

County shall pay, and Contractor shall accept Contractor's Bid Prices, as shown on EXHIBIT "A" attached hereto and made a part hereof, as full compensation for furnishing all materials and for doing all the work contemplated and embraced in this Agreement; also for all loss or damage, arising out of the work aforesaid, or from the actions of the elements, or from any unforeseen difficulties or obstructions which may arise or be encountered in the prosecution of the work until its acceptance by County, and for all risks of every description connected with the work; also for all expenses incurred by or in consequence of the suspension or discontinuance of the work and for well and faithfully completing the work, and the whole thereof, in the manner and according to the Plans and Specifications, and the requirements of the Engineer.

Section 3 - CONTRACT DOCUMENTS

The complete contract between the parties hereto shall consist of the following, hereinafter referred to as the CONTRACT DOCUMENTS:

- Notice to Contractors
- Plans and Drawings
- Bid Form
- Bidder's Bond
- Performance Bond
- Payment Bond
- This Agreement
- Special Provisions

And, as published by the Department of Transportation, State of California, except as modified by the Special Provisions:

- Standard Plans - dated 2010
- Standard Specifications - dated 2010
- Equipment Rental Rates in effect at the time the work is performed

And, as published by the California Department of Industrial Relations, and the California Business, Transportation and Housing Agency,

- General Prevailing Wage Rates
- Labor and Surcharge Rates

And any addenda to any of the above documents, all of which are on file in the office of the Director of Public Works of the County of Humboldt. Each of said CONTRACT DOCUMENTS is incorporated and made a part of this Agreement by the reference contained in this Section.

All rights and obligations of the County and the Contractor are fully set forth and described in the Contract Documents. All of the above named documents are intended to be complimentary, so that any work called for in one, and mentioned in the other is to be performed and executed the same as if mentioned in all said documents.

Section 4 - BEGINNING OF WORK

Following receipt and full execution and approval of the Contract Documents, and posting of the requisite Bonds as called for therein, the COUNTY will issue a "Notice to Proceed". Under no circumstances shall the CONTRACTOR enter upon the site of work until receipt of the "Notice to Proceed", or unless so authorized in writing by the COUNTY.

Section 5 - TIME OF COMPLETION

The work called for in this Agreement shall be commenced within fifteen (15) days of the date of execution of the contract by COUNTY and shall be fully completed within a period of 40 working days beginning on the fifteenth calendar day after the date of said approval of contract.

Section 6 - PREVAILING WAGE

Copies of the prevailing wage rates of per diem wages are on file in the Humboldt County Public Works office at 1106 Second Street, Eureka, California and are available to any interested person on request.

Section 7 - WORKERS' COMPENSATION

By my signature hereunder, as CONTRACTOR, I certify that I am aware of the provisions of Section 3700 of the Labor Code which requires every employer to be insured against liability for Workers' Compensation or to undertake self insurance in accordance with the provisions of that code, and I will comply with such provisions before commencing the performance of the work of this contract.

Section 8 - COMPLIANCE WITH LAWS

The Contractor agrees to comply with all local, state and federal laws and regulations, including but not limited to the Americans With Disabilities Act. The Contractor further agrees to comply with any applicable federal, state or local licensing standards, any applicable accrediting standards, and any other applicable standards or criteria established locally or by the state or federal governments.

This agreement shall be governed by and construed in accordance with the laws of the State of California.

Section 9 - NOTICES

All notices shall be in writing and delivered in person or transmitted by mail. Notices required to be given to the COUNTY shall be addressed as follows:

Humboldt County Department of Public Works
1106 Second Street, Eureka, California, 95501

Notices required to be given to CONTRACTOR shall be addressed as follows:

IN WITNESS WHEREOF, The parties hereto have entered into this Agreement as of the date first above set forth.

COUNTY OF HUMBOLDT

(SEAL) BY _____
Chairman, Board of Supervisors
of the County of Humboldt,
State of California

ATTEST:
KATHY HAYES
Clerk of the Board of Supervisors
of the County of Humboldt,
State of California

BY _____
Clerk of the Board

CONTRACTOR

BY _____

TITLE _____

BY _____

TITLE _____

(Two Signatures Required For Corporation)

APPROVED AS TO FORM:

BY _____
Deputy County Counsel

INSURANCE CERTIFICATES REVIEWED
AND APPROVED:

BY _____
Risk Manager

PAYMENT BOND

KNOW ALL MEN BY THESE PRESENTS :

THAT WHEREAS , the County of Humboldt, by its order made _____ ,
20____, has awarded to _____
hereinafter designated as the "Principal," a contract for the work described as follows:

NOW , THEREFORE , we the Principal and _____
_____, Surety, are held and firmly bound unto the
County of Humboldt in the penal sum of _____
Dollars (\$ _____) , lawful money of the United States of America for the payment of which
sum well and truly to be made, we bind ourselves, our heirs, executors, administrators, successors and assigns,
jointly and severally, firmly by these presents.

THE CONDITION OF THIS OBLIGATION IS SUCH that if said Principal, his or its subcontractors,
heirs, executors, administrators, successors, or assigns, shall fail to pay any of the persons named in Section
3181 of the Civil Code, or amounts due under the Unemployment Insurance Code, with respect to work or labor
performed by claimant, or for any amounts required to be deducted, withheld, and paid over to the Franchise Tax
Board from the wages of employees of the Contractor and his subcontractors pursuant to Section 18806 of the
Revenue and Taxation Code with respect to such work and labor as required by Sections 3247 et seq. of the
Civil Code of California, then said Surety will pay for the same, in or to an amount not exceeding the amount
hereinafter set forth, and also will pay in case suit is brought upon this bond, such reasonable attorney's fees, as
shall be fixed by the court, awarded and taxed as in the above-mentioned statutes provided.

AND , the said Surety, for value received, hereby stipulates and agrees that no change, extension of time,
alteration or addition to the terms of the contract or to the work to be performed thereunder or the specifications
accompanying the same shall in any wise affect its obligations on this bond, and it does hereby waive notice of
any such change, extension of time, alteration or addition to the terms of the contract, or to the work, or to the
specifications.

IN WITNESS WHEREOF , this instrument has been duly executed by Principal and Surety above named,
on the _____ day of _____, 20____ .

PRINCIPAL
BY _____

SURETY
BY _____
Attorney-in-fact

PERFORMANCE BOND

KNOW ALL MEN BY THESE PRESENTS : that

(Name of Contractor)

(Address of Contractor)

a _____, hereinafter called Principal, and
(Corporation , Partnership , or Individual)

Name of Surety)

(Address of Surety)

hereinafter called Surety, are held and firmly bound unto _____

(Name of Owner)

(Address of Owner)

hereinafter called Owner , in the penal sum of _____

_____ Dollars , \$ _____

in lawful money of the United States, for the Payment of which sum well and truly to be made, we bind ourselves, successors, and assigns, jointly and severally, by these presents.

THE CONDITION OF THIS OBLIGATION is such that whereas, the Principal entered into a certain contract with the OWNER, dated the _____ day of _____, 20 __ , a copy of which is hereto attached and made a part hereof for the construction of :

NOW , THEREFORE , if the Principal shall well , truly and faithfully perform its duties, all of the undertakings, covenants, terms, conditions, and agreements of said contract during the original term thereof, and any extensions thereof which may be granted by the OWNER, with or without notice to the Surety and during the one year guaranty period, and if he shall satisfy all claims and demands incurred under such contract, and shall fully indemnify and save harmless the OWNER from all costs and damages which it may suffer by reason of failure to do so, and shall reimburse and repay the OWNER all outlay and expense which the OWNER may incur in making good any default, then this obligation shall be void; otherwise to remain in full force and effect.

PROVIDED , FURTHER , that the said surety, for value received hereby stipulate and agrees that no change, extension of time, alteration or addition to the specifications accompanying the same shall in any wise affect its obligation on this BOND , and it does hereby waive notice of any such change, extension of time, alteration or addition to the terms of the contract or to the WORK or to the SPECIFICATIONS.

PROVIDED , FURTHER , that no final settlement between the OWNER and the CONTRACTOR shall abridge the right of any beneficiary hereunder, whose claim may be unsatisfied.

IN WITNESS WHEREOF, this instrument is executed in ____ counterparts, one of which shall
(number)
be deemed an original, this the _____ day of _____, 20__.

ATTEST :

(Principal) Secretary
(SEAL)

Principal
BY _____ (s)

(Witness as to Principal)

Address

Address

Surety

ATTEST :

(SEAL)

(Witness as to Surety)

Address

BY _____
Attorney - in - Fact

Address

NOTE : Date of BOND must not be prior to date of contract. If CONTRACTOR is Partnership, all partners should execute BOND.

IMPORTANT : Surety companies executing BONDS must appear on the Treasury Department's most current list (Circular 570 as amended) and be authorized to transact business in the state where the PROJECT is located.

PROJECT NO.	438002	SECTION	REHABILITATION OF REDWAY STATION	SHEET NO.	1
DATE	06/30/16	SCALE	AS SHOWN	OF	3
DESIGNER	W&A	PROJECT NO.	438002	PROJECT NAME	REHABILITATION OF REDWAY STATION
DATE	06/30/16	PROJECT NO.	438002	PROJECT NAME	REHABILITATION OF REDWAY STATION
DESIGNER	W&A	PROJECT NO.	438002	PROJECT NAME	REHABILITATION OF REDWAY STATION
DATE	06/30/16	PROJECT NO.	438002	PROJECT NAME	REHABILITATION OF REDWAY STATION

COUNTY OF HUMBOLDT
DEPARTMENT OF PUBLIC WORKS
PROJECT PLANS FOR CONSTRUCTION OF
REDWAY TRANSFER STATION
REHABILITATION PROJECT
CONTRACT NO. 438002

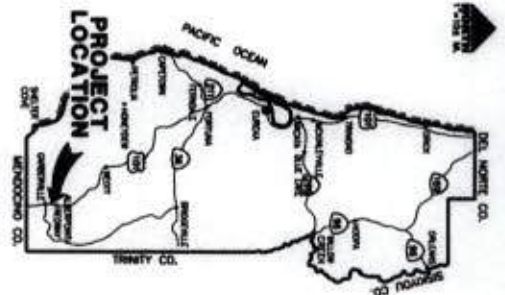
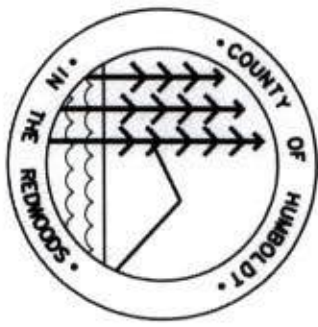
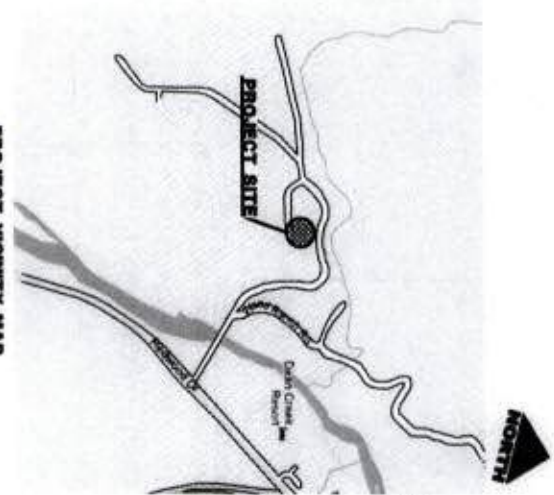

- INDEX OF SHEETS**
- 1 COVER SHEET
 - 2 GRADING AND DRAINAGE PLAN
 - 3 CONSTRUCTION DETAILS

APPLICABLE STANDARD PLANS

REFERENCE TO CALIFORNIA STANDARD PLANS DATED MAY 2010

UNIFORM CONSTRUCTION CODE

CALIFORNIA HEALTH & SAFETY CODE

HUMBOLDT COUNTY CODE - TITLE 19 CHAPTER 2 SECTION 612-4

HUMBOLDT COUNTY CODE - TITLE 19 CHAPTER 1 SECTION 611-4

OR 10 DIVISION 10

NOTES

THE CONTRACTOR SHALL HAVE A CLASS "A" LICENSE FOR THIS PROJECT.

APPROVED



 CHRISTOPHER J. WHITWORTH
 REG. 51931, EXP. 6/30/16
 DATE: 06/30/16



PROJECT LIST BOI PRICE

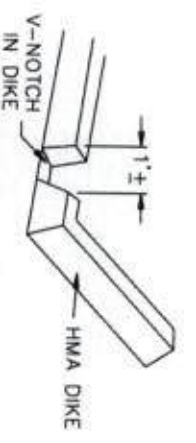
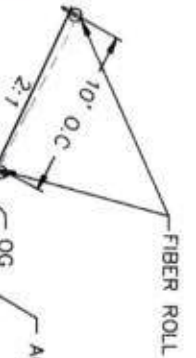

DATE: 10/15/10	PROJECT: REBAR TANGLED STATION REHABILITATION	SHEET NO: 2
SCALE: 1" = 20'	DR: [Redacted]	OF: 3
DATE: 10/15/10	PROJECT: REBAR TANGLED STATION REHABILITATION	SHEET NO: 3
SCALE: 1" = 20'	DR: [Redacted]	OF: 3
DATE: 10/15/10	PROJECT: REBAR TANGLED STATION REHABILITATION	SHEET NO: 3
SCALE: 1" = 20'	DR: [Redacted]	OF: 3



DIKE DRAIN
NOT TO SCALE

FIBER ROLLS
NOT TO SCALE

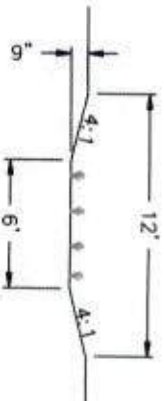

VEGETATED SWALE
NOT TO SCALE

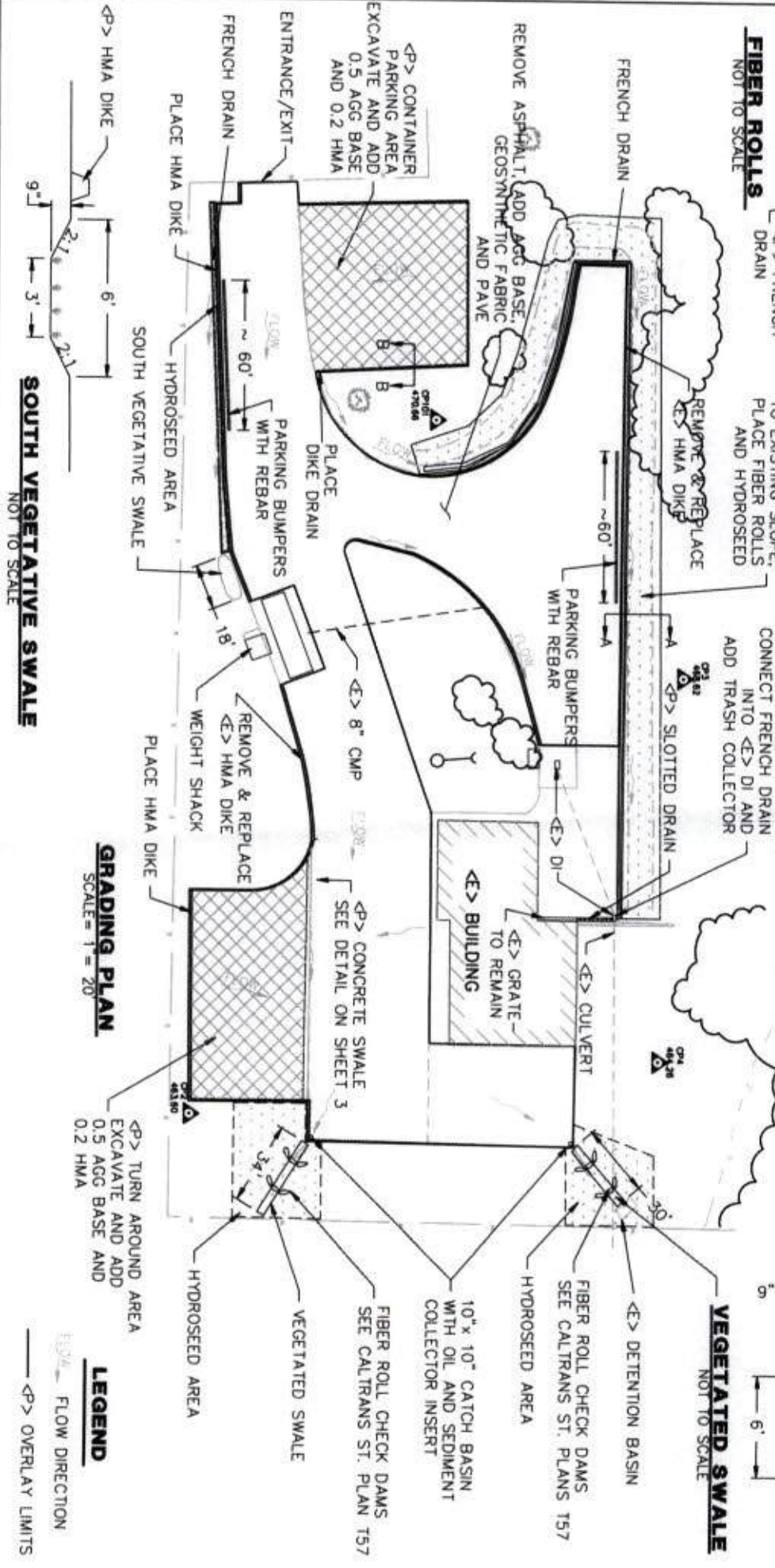

SOUTH VEGETATIVE SWALE
NOT TO SCALE

GRADING PLAN
SCALE = 1" = 20'

LEGEND

— FLOW DIRECTION
— OVERLAY LIMITS



PROJECT NO.	DATE
DRAWN BY	CHECKED BY
SCALE	DATE
PROJECT TITLE	PROJECT LOCATION
PROJECT NO.	DATE

REGION SECTION	COUNTY OF HAMBOROUGH
SHEET NO.	DEPARTMENT OF PUBLIC WORKS
TOTAL SHEETS	ROADWAY TRAFFIC SIGNAL REHABILITATION
DATE	CONSTRUCTION DETAILS
3	3

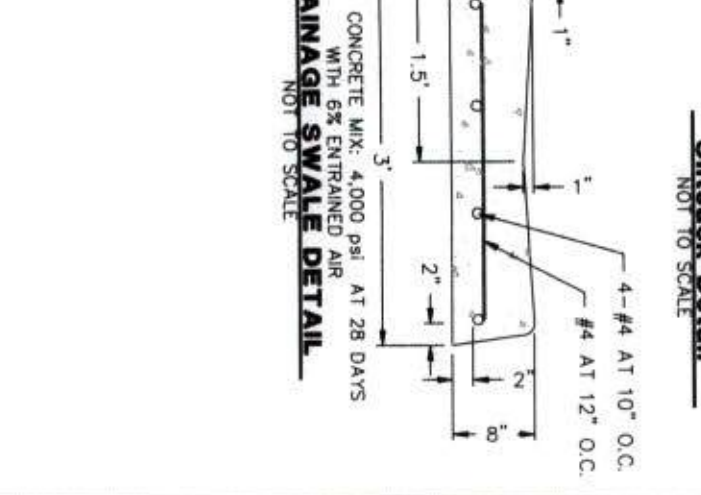
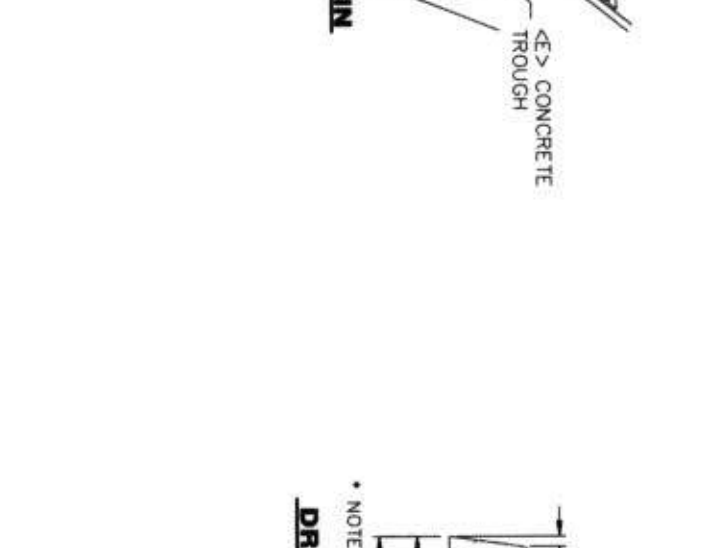
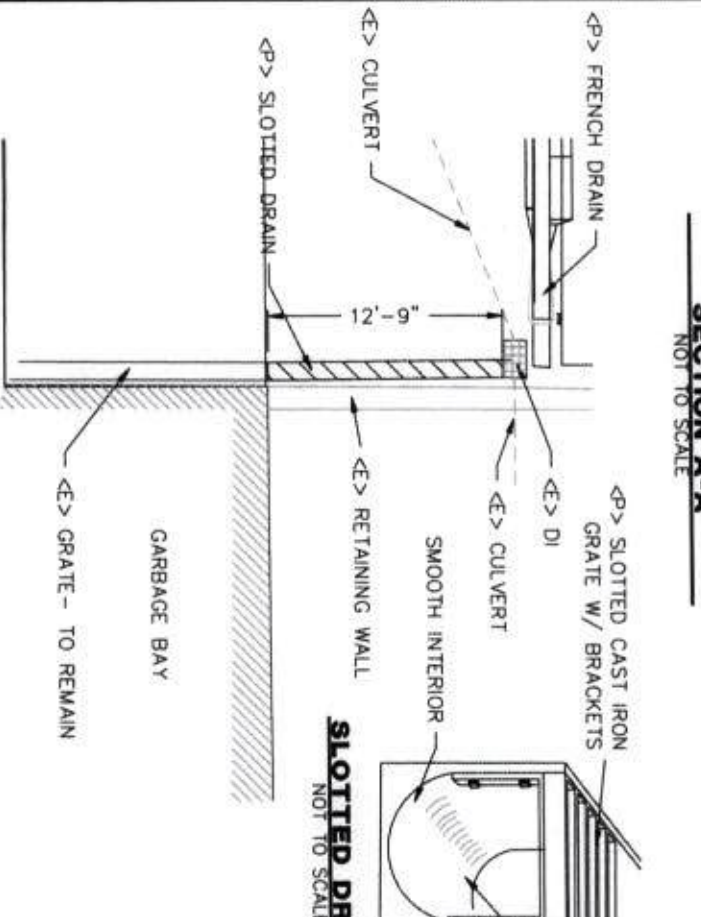
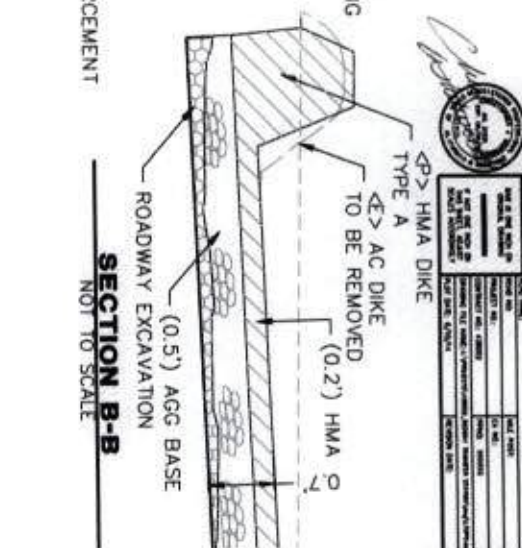
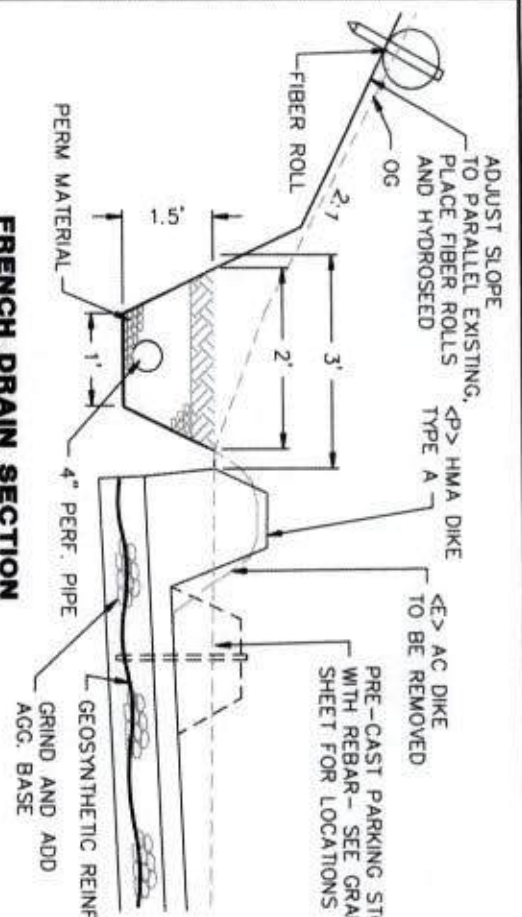

SLOTTED DRAIN LOCATION
NOT TO SCALE

FRENCH DRAIN SECTION SECTION A-A
NOT TO SCALE

SECTION B-B
NOT TO SCALE

SLOTTED DRAIN
NOT TO SCALE

Siltstack Detail
NOT TO SCALE

DRAINAGE SWALE DETAIL
NOT TO SCALE

NOTE: CONCRETE MIX: 4,000 psi AT 28 DAYS WITH 6% ENTRAINED AIR