



Lost Coast Elixirs LLC
569 Eubanks Rd, Garberville CA 95542
Permit Application 11247

Re: Water & Energy Calculation for Pre-Existing vs. Current Cultivation Area

This application is proposing to reduce the overall canopy area from pre-existing 28,065 square feet to current 23,854 square feet. This change includes reducing the outdoor area from 22,514 square feet to 16,144 square feet and then increasing the mixed light area from 5551 square feet to 7710 square feet.

Water Usage:

The reduction in overall canopy results in a 3052 gallon per week reduction in water use during the dry season (May through September). The estimated water saved is over 61,000 gallons each season. The increased mixed light operation would result in approximately 16,604 extra gallons used, however the extra water would be sourced during the wetter winter months which would have a minimal impact. The overall result would be 44,436 gallons saved with the reduction.

Mixed Light Increase
1387 gallons per week
1980 gallons per week
593 per week
16,604 total increase

Outdoor Decrease
15,435 gallons per week
12,382 gallons per week
3052 per week
61,040 total decrease

Overall decrease of 44,436 gallons

Energy Usage:

The mixed light operation is powered by generator use. The generators used can support the increased wattage in the mixed light area without increased use. The generators would run at a higher load capacity than the pre-existing output which would result in the machine running more efficiently. The recommended load capacity for highest efficiency for the MQ 220 is 80% (176 kw output). The hours of use would also not be any different with the increased area.

Pre-Exiting Grow Light Watts 138,775 / 208V = 667 amps (62% load; 139 kw output)
Current Grow Light Watts 192,750 / 208V = 926 amps (87% load; 193 kw output)
Prime Output = 176 kw; 80% load

MQ POWER[®]

MQ Power Super-Silent WhisperWatt 220 to 800 kVA - Single / Three Phase

Model	DCA220SSCU4i	DCA300SSCU4i	DCA400SSI4F	DCA600SSVC	DCA800SSK2C
Generator					
Design	Revolving Field Self-Ventilated Drip-Proof Single Bearing				
No. of Poles	4-poles				
Excitation	Brushless with AVR				
Standby Output	194 kW (242KVA)	264 kW (330kVA)	336 kW (420kVA)	528 kW (660kVA)	704 kW (880kVA)
Prime Output	176 kW (220kVA)	240 kW (300kVA)	320 kW (400kVA)	480 kW (600kVA)	640 kW (800kVA)
Generator RPM	1800				
Voltage - 3 phase	208, 220, 240, 416, 440, 480V Reconnectable				
Voltage - 1 phase	120, 127, 139, 240, 254, 277V Adjustable				
Armature Connection	Star with neutral				
Voltage Regulation (No Load to Full Load)	± 0.5%				
Frequency	60 Hz				
Frequency Regulation (No Load to Full Load)	± 0.25% Electric Governor				
Power Factor	0.8				
Sound Level dB (A) Full Load at 23 Feet	75	75	69	74	73
Diesel Engine					
Make / Model	Cummins QSB7-G6	Cummins QSL9-G8	Isuzu BQ-6WG1X	Volvo TAD1642GE	Komatsu SAA6D170E-3
Emissions	Tier 4i	Tier 4i	Tier 4 Final	Tier 2	Tier 2
Starting System	Electric				
Design	4-cycle Water Cooled Direct Injection Turbocharged Charge Air Cooled EGR		4-cycle Water Cooled Direct Injection Turbocharged Charge Air Cooled EGR, DOC and SCR	4-cycle Water Cooled Direct Injection Turbocharged Charge Air Cooled	
Displacement	6,700 cc	8,900 cc	15,681 cc	16120 cc	23,150 cc
No. of Cylinders	6	6	6	6	6
Bore x Stroke (mm)	107 x 124	114 x 145	147 x 154	144 x 165	170 x 170
Gross Engine Power Output	314	433	512.3	809	1,220
Full Tank Capacity gal. (liters)	100 (380)	129 (490)	55.5 (210)	129 (490)	129 (490)
Fuel consumption					
full load gph (lph)	12.4 (46.8)	16.3 (61.8)	22.5 (85.1)	33.1 (125.2)	41.3 (156.5)
3/4 load gph (lph)	9.5 (36.0)	14.1 (53.3)	17.3 (65.5)	24.2 (91.7)	30.8 (116.4)
1/2 load gph (lph)	6.9 (26.0)	12.0 (45.5)	12.2 (46.0)	17.3 (65.4)	22.6 (85.9)
1/4 load gph (lph)	4.4 (16.8)	7.05 (26.7)	7.7 (29.0)	10.5 (39.6)	14.5 (54.9)
DEF Tank Capacity gal. (liters)	N/A	N/A	14.8 (56)	N/A	N/A
Coolant Capacity gal. (liters)	11.4 (43.0)	14.0 (53.0)	19.4 (73.6)	24.6 (93.0)	39.1 (148)
Oil Capacity gal. (liters)	4.6 (17.5)	6.0 (22.7)	15.1 (57)	12.7 (48.0)	37.2 (141)
Battery	12V 100Ah x 2 24V System	12V 150Ah x 2 24V System	12V 200Ah x 2 24V System	12V 200Ah x 2 24V System	12V 200Ah x 4 24V System
Size					
L x W x H in. (cm)	138 x 52 x 69 (350 x 130 x 175)	150 x 59 x 71 (380 x 150 x 180)	181 x 59 x 89 (460 x 150 x 225)	185 x 65 x 94 (470 x 165 x 240)	241 x 77 x 98 (611 x 195 x 250)
Approx Net Wt lbs. (kg)	6,636 (3,010)	8,642 (3,920)	12,280 (5,570)	16,373 (7,425)	23,634 (10,720)
Amps					
Single Phase 120V	488.9A (4 wire)	666.7A (4 wire)	888.9A (4 wire)	1,333.3A (4 wire)	1,777.8A (4 wire)
Single Phase 240V	244.4A (4 wire)	333.3A (4 wire)	444.4A (4 wire)	666.7A (4 wire)	888.9A (4 wire)
Three Phase 240V	529A	722A	962A	1443A	1924A
Three phase 480V	265A	361A	481A	721A	962A

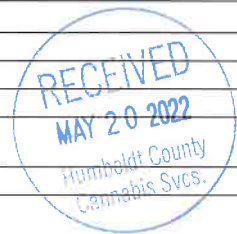

Features and specifications are subject to change without notice
 Units manufactured by Denyo Manufacturing Corp.
 Copyright 2014, Multiquip Inc. DW1114



Acevedo, Megan

From: Jasmin Holmgren <jasmin@lostcoastexotics.com>
Sent: Tuesday, June 07, 2022 10:04 AM
To: Johnson, Cliff
Cc: Acevedo, Megan; Tommy Harwood; Ford, John; Bushnell, Michelle
Subject: Re: Lost Coast Elixirs 11247
Attachments: Application 11247-CUP.pdf

Caution: This email was sent from an EXTERNAL source. Please take care when clicking links or opening attachments.

Hi Megan,

I was able to discuss this with Mr Harwood this morning. In an effort to reduce fuel consumption, timers were installed on the generators at the beginning of this year. We have seen a reduction of 40% in consumption since then. We have eliminated over use and employee error. The increased mixed light area is less than 40%, so overall there will be a small reduction in fuel consumption. We will continue to use the timers in the operation and will try to explore other ways to reduce fuel consumption however possible.

Please let me know if I need to amend the Ops Plan or Energy Calculation page to include this information. Until yesterday it hadn't been asked of us to include fuel consumption info so let me know if you need that added.

Thank you,

Jasmin Holmgren



State Water Resources Control Board

Sent by email. No hard copy to follow.

Effective Date: 7/20/2021

WDID: 1_12CC435453

Lost Coast Elixirs, Llc
Attn: Thomas Harwood
Email: Admin@Lostcoaste.Com

FACILITY ADDRESS:
569 Eubanks Road
Garberville CA, 95542
Humboldt County

NOTICE OF APPLICABILITY – WASTE DISCHARGE REQUIREMENTS, WATER QUALITY ORDER WQ 2019-0001-DWQ

This Notice of Applicability (NOA) provides notice that the requirements of the State Water Resources Control Board (State Water Board) *Cannabis Cultivation Policy- Principles and Guidelines for Cannabis Cultivation* (Policy), and Order WQ 2019-0001-DWQ (General Order), are applicable to the site as described below.

DISCHARGER: LOST COAST ELIXIRS, LLC

WDID: 1_12CC435453	ORDER: WQ 2019-0001-DWQ
Enrollment – Type	Enrollee - WDR
Tier and Risk	Tier 2 Low Risk
Wastewater Disposal	Not Applicable
Disturbed Area (SqFt)	48611
Cultivation Area (SqFt)	35039

FACILITY APNs:

220-081-016-000

Additional site-specific requirements are contained in this NOA. The Discharger is responsible for all the applicable requirements in the Policy, General Order, and this NOA.

If you have any further question, please contact North Coast Regional Cannabis Unit at northcoast.cannabis@waterboards.ca.gov

APPROVED BY

Karen Mogus
Deputy Director
Division of Water Quality

E. JOAQUIN ESQUIVEL, CHAIR | EILEEN SOBECK, EXECUTIVE DIRECTOR

The *Cannabis Cultivation Policy- Principles and Guidelines for Cannabis Cultivation* (Policy) and the *General Waste Discharge Requirements and Waiver of Waste Discharge Requirements for Discharges of Waste Associated with Cannabis Cultivation Activities*, Order WQ 2019-0001-DWQ (General Order) are available at <<http://www.waterboards.ca.gov/cannabis>>. The Discharger shall ensure that all site operating personnel know, understand, and comply with the requirements contained in the Policy, General Order, and this Notice of Applicability (NOA). Note that the General Order contains standard provisions, general requirements, and prohibitions that apply to all cannabis cultivation activities (Attachment A of the General Order).

Please direct submittals, discharge notifications, and questions regarding compliance and enforcement to the North Coast Regional Cannabis Unit Regional Cannabis Unit, at (707) 576-2676 or northcoast.cannabis@waterboards.ca.gov unless otherwise directed in this document.

CONTENTS:

1. **ENROLLMENT RESPONSIBILITIES**
2. **FACILITY AND DISCHARGE DESCRIPTION**
3. **PROJECTS AND MAINTANCE OCCURING IN STREAMS AND WETLANDS**
4. **GENERAL REQUIERMENTS**
5. **TECHNICAL REPORT REQUIRMENTS**
6. **MONITORING AND REPORTING PROGRAM**
7. **ANNUAL FEE**
8. **TERMINATION OF COVERAGE UNDER THE GENERAL ORDER**
9. **REGION SPECIFIC REQUIERMENTS**

Additional Cannabis Water Quality Resources

The links below are available on the last page of this document

Water Boards' Cannabis Cultivation Webpage	Water Quality Fees Webpage
Cannabis Policy	Water Quality Annual Fee Invoice Lookup
Cannabis General Order	Facility-At-A-Glance Report
Rural Roads Handbook	Cultivation Permitting Agency Webinar

For translation assistance, please contact the following:

Spanish: Para obtener más información en español por favor contáctenos al teléfono (916) 341-5265 o vía email a: OPP-LanguageServices@Waterboards.ca.gov.

Hmong: Rau kev npaub ntxiv ua lus Hmoob, thov txuas lus nrog peb ntawm xov tooj (916)-341-5265 los sis email: OPP-LanguageServices@Waterboards.ca.gov.

1. ENROLLMENT RESPONSIBILITIES

Lost Coast Elixirs, Llc (hereafter "Discharger") submitted information, or updated enrollment information, for discharges of waste associated with cannabis cultivation at or near 569 Eubanks Road Garberville CA, 95542. The Discharger's cannabis cultivation activities are in compliance, will be in compliance with, or the Discharger will contact the Regional Board if they cannot be in compliance with the requirements of the State Water Board's Policy and General Order before the winter period. You are hereby assigned waste discharger identification (WDID) number 1_12CC435453.

The Discharger is responsible for all applicable requirements in the Policy, General Order, and this NOA, including submittal of all required reports. The Discharger is the sole person with legal authority to, among other things, change information submitted to obtain regulatory coverage under the General Order; request changes to enrollment status, including tier and risk designation; and terminate regulatory coverage. The Discharger may designate a third-party representative/agent to represent them in issues related to the General Order but must do so in writing. The Regional Water Quality Control Board (Regional Water Board) or the State Water Board (collectively Water Boards) will hold the Discharger liable for any noncompliance with the Policy, General Order, or this NOA. Pursuant to the General Order, if the Discharger is not the landowner, the Discharger must have express written permission of the landowner authorizing the cannabis cultivation activities. If the landowner contests this NOA and the Discharger cannot obtain consent, the Discharger will be required to submit a request for termination of coverage under the General Order, as described in Section 5 below.

This NOA does not provide authorization to cultivate cannabis; such authorization is provided through a license from the California Department of Food and Agriculture (CalCannabis), required permits from your local jurisdiction (city or county), and an agreement or exemption from agreement from the California Department of Fish and Wildlife. The Policy and General Order, and by reference this NOA, require that you obtain all appropriate permits from other agencies prior to cultivating cannabis.

2. FACILITY AND DISCHARGE DESCRIPTION

The information submitted by the Discharger indicates:

1. the disturbed area is greater than or equal to 1 acre (43,560 square feet)
2. no portion of the disturbed area is within the required riparian setbacks
3. no portion of the disturbed area is located on a slope greater than 30 percent

Therefore, the activities are classified as Tier 2 Low Risk and meet the requirements of the General Order.

If site conditions described above change, you must contact the North Coast Regional Cannabis Unit listed at the top of page 2.

3. PROJECTS AND MAINTANCE OCCURING IN STREAMS AND WETLANDS

The Policy and General Order require that, prior to conducting any work in streams or wetlands, the Discharger obtain water quality certification from the Water Boards and other required permits from other agencies (e.g., a Clean Water Act section 404 permit from the United States Army Corps of Engineers, a Lake and Streambed Alteration Agreement from the California Department of Fish and Wildlife, and other local permits). Enrollment in the General Order requires that the Discharger obtain water quality certification for any such work, but this NOA does not provide the necessary certification. If the Discharger proposes or requires work in streams or wetlands, they must apply for water quality

certification by filling out and submitting a separate application for that work. Additional application and monitoring fees will apply. Please contact the North Coast Regional Cannabis Unit for application forms, fee information, and instructions.

4. GENERAL REQUIERMENTS

The General Order requires that all applicable best practicable treatment or control (BPTC) measures listed in Attachment A of the General Order be implemented before the onset of the winter period November 15 to April 1. Dischargers that cannot implement all applicable BPTC measures by the onset of the winter period shall submit to the Regional Water Board a Site Management Plan that includes a time schedule and scope of work for use by the Regional Water Board in developing a compliance schedule as described in General Requirement No. 33 in Attachment A of the General Order.

The Discharger shall notify the Regional Water Board in writing of any proposed change in the method of waste disposal for irrigation tailwater, hydroponic wastewater, or other miscellaneous industrial wastewaters. Note the following:

- i. Discharge to a permitted wastewater treatment collection system and facility that accepts cannabis cultivation wastewater is permissible under the General Order. A will-serve letter (or equivalent) from the sewer agency is sufficient to demonstrate that the discharge is in compliance with wastewater system requirements and shall be made available to the Water Boards upon request.
- ii. The Discharger shall retain, for a minimum of five years, appropriate documentation for any industrial wastewater collected to a storage tank for disposal at a permitted wastewater facility that accepts cannabis cultivation wastewater. Documentation shall be made available to the Water Boards upon request.
- iii. The Discharger must obtain separate regulatory authorization (e.g., site-specific Waste Discharge Requirements (WDRs), conditional waiver of WDRs, or other permit mechanism) from the Regional Water Board prior to implementing alternative waste disposal methods, such as onsite wastewater treatment systems, including, but not limited to, a septic/leach field system, evaporation ponds, or onsite landscape irrigation using treated wastewater. Additional monitoring and reporting requirements may be necessary to demonstrate compliance with the General Order and the Regional Water Board's Basin Plan.

During reasonable hours, the Discharger shall allow the Water Boards, California Department of Fish and Wildlife, CAL FIRE, and any other authorized representatives of the Water Boards, upon presentation of a badge, employee identification card, or similar credentials, to:

- i. enter premises and facilities where cannabis is cultivated; where water is diverted, stored, or used; where wastes are treated, stored, or disposed; or in which any records are kept;
- ii. access and copy any records required to be kept under the terms and conditions of the Policy and General Order;
- iii. record audio and video, inspect, and/or photograph any cannabis cultivation sites, and associated premises, facilities, monitoring equipment or device, practices, or operations regulated or required by the Policy and General Order; and

- iv. sample, monitor, photograph, and record audio and video of site conditions, any discharge, waste material substances, or water quality parameters at any location for the purpose of ensuring compliance with the Policy and General Order.

5. TECHNICAL REPORT REQUIREMENTS

The technical reports described below shall be submitted through the Water Boards Cannabis Cultivation Programs Portal by completing a *General Order Technical Reporting* survey. See Section 8 for required reporting before termination of General Order coverage.

A Site Management Plan, due by 7/31/2021, as required by General Order Provision C.1.a. and Attachment A, Section 5. Attachment D of the General Order provides guidance on the contents of the Site Management Plan

6. MONITORING AND REPORTING PROGRAM

The Discharger shall comply with the Monitoring and Reporting Program (MRP). Attachment B of the General Order provides guidance on the contents for the annual reporting requirement. Annual reports shall be submitted through the Water Boards Cannabis Cultivation Programs Portal by completing a *Online Cannabis Water Quality Monitoring & Reporting Program* survey by March 1 following the year being monitored. The Discharger shall comply with the MRP and any future revisions as specified by the Regional Water Board Executive Officer, the State Water Board Division of Water Quality Deputy Director, or the State Water Board Chief Deputy Director.

7. ANNUAL FEE

If applicable you will receive an invoice annually until coverage under this General Order is formally terminated. Please visit http://www.waterboards.ca.gov/resources/fees/water_quality/ and click on the latest Water Quality Fee Schedule (for example, for fiscal year 2020-2021, the fee schedule is called 'FY 2020-2021 Water Quality Fee Schedule'). California Code of Regulation Title 23 Division 3 Chapter 9 Article 1 Section 2200.7, 'Annual Fee Schedule for Cannabis Cultivation.' Please note that the Fee Schedule is reviewed annually and future fees may be invoiced at different rates.

Annual fees are assessed on a fiscal year basis (July 1 through June 30). Invoices are sent by the State Water Board roughly midway through each fiscal year, usually in January. Please do not submit payments without receiving an invoice. If you have questions or concerns about your fees please contact the Water Boards Fee Branch at FeeBranch@waterboards.ca.gov or (916) 341-5247. The fee is due and payable on an annual basis until coverage under the General Order is formally terminated. Instructions for requesting termination of coverage appear in Section 8.

To terminate coverage, the Discharger must submit a Notice of Termination, including a Site Closure Report, at least 90 days prior to termination of activities, and a final Annual Monitoring Report. See Termination of Coverage Under the General Order section below.

8. TERMINATION OF COVERAGE UNDER THE GENERAL ORDER

Dischargers who wish to terminate coverage under the General Order must submit to the Regional Water Board a *Notice of Termination (NOT)*, along with a *Site Closure Report*. The NOT and Site Closure Report shall be submitted through the Water Boards Cannabis Cultivation Programs Portal <https://public2.waterboards.ca.gov/cgo> by completing a *Cannabis General Order Termination Request Form* survey.

Dischargers enrolled under Waste Discharge Requirements in the General Order (i.e., non-Waiver enrollees) must also submit a final Annual Monitoring Report. The final Annual Monitoring Report shall be submitted by completing an *Online Cannabis Water Quality Monitoring & Reporting Program* survey.

The Regional Water Board reserves the right to inspect the site before approving a request for termination of coverage. Attachment C of the General Order includes the *NOT* form and Attachment D of the General Order provides guidance on the contents of the *Site Closure Report*.

9. REGION SPECIFIC REQUIERMENTS

Dischargers shall comply with all applicable federal, state, and local laws, regulations, and permitting requirements. This includes any applicable Regional Water Board Orders or Regional Water Quality Control Plan (Basin Plan) requirements, including prohibitions and/or water quality objectives governing the discharge. In the event of duplicate or conflicting requirements, the most stringent requirement shall apply.

You can access your regions Basin Plan by visiting your local Regional Water Board's website at <https://www.waterboards.ca.gov/northcoast/>.

The Discharger shall also comply with the provisions of the North Coast Regional Water Board's Supplement to the General Order Annual Monitoring and Reporting Program (Regional Supplement), which independently appears as Investigative Order No. R1-2019-0023, issued by the Regional Water Board Executive Officer on March 22, 2019. The information required by Order No. R1-2019-0023 will be submitted while completing the *Online Cannabis Water Quality Monitoring & Reporting Program* survey

Individuals Notified of Notice of Applicability Issuance

Kevin Porzio, State Water Resources Control Board
dwq.cannabis@waterboards.ca.gov

North Coast Water Quality Control Board
Northcoast.Cannabis@Waterboards.Ca.Gov

Cliff Johnson, Senior Planner
Humboldt County
Cjohnson@Co.Humboldt.Ca.Us

210720_2L_1_12CC435453_Lost_Coast_Elixirs__Eb_NOA_BTM

Additional Cannabis Water Quality Resources

Water Boards' Cannabis Cultivation Webpage:

https://www.waterboards.ca.gov/water_issues/programs/cannabis/cannabis_outreach.html

Cannabis Policy:

https://www.waterboards.ca.gov/water_issues/programs/cannabis/docs/policy/final_cannabis_policy_with_attach_a.pdf

Cannabis General Order:

https://www.waterboards.ca.gov/board_decisions/adopted_orders/water_quality/2019/wqo2019_0001_dwq.pdf

Rural Roads Handbook:

http://www.pacificwatershed.com/sites/default/files/handbook_chapter_download_page.pdf

Cultivation Permitting Agency Webinar: <https://youtu.be/kVbIKnFRZy8>

Water Quality Fees Webpage: https://www.waterboards.ca.gov/resources/fees/water_quality/

Water Quality Annual Fee Invoice Lookup:

<http://infofees.waterboards.ca.gov/FeeInfo/DischargerInvoice.aspx>

Facility-At-A-Glance Report:

<https://ciwqs.waterboards.ca.gov/ciwqs/readOnly/CiwqsReportServlet?reportName=facilityAtAGlance&inCommand=reset>

**Water Resource Protection Plan
For
WDID #1B16459CHUM**

Submitted to:

Thomas Harwood

Prepared by:

Timberland Resource Consultants
165 South Fortuna Blvd
Fortuna, CA 95540

9-28-2016

Purpose

This Water Resource Protection Plan (WRPP) has been prepared on behalf of the discharger, by agreement and in response to the California Water Code Section 13260(a), which requires that any person discharging waste or proposing to discharge waste within any region that could affect the quality of the waters of the state, other than into a community sewer system, shall file with the appropriate regional water board a Report of Waste Discharge (ROWD) containing such information and data as may be required by the Regional Water Board. The Regional Water Board may waive the requirements of Water Code section 13260 for specific types of discharges if the waiver is consistent with the Basin Plan and in the public interest. Any waiver is conditional and may be terminated at any time. A waiver should include monitoring requirements to verify the adequacy and effectiveness of the waiver's conditions. Order R1-2015-0023 conditionally waives the requirement to file a ROWD for discharges and associated activities described in finding 4.

Scope of Report

Order No. R1-2015-0023 states that "Tier 2 Dischargers and Tier 3 Dischargers who intend to cultivate cannabis before, during, or following site cleanup activities shall develop and implement a water resource protection plan that contains the elements listed and addressed below. Dischargers must keep this plan on site, and produce it upon request by Regional Water Board staff. Management practices shall be properly designed and installed, and assessed periodically for effectiveness. If a management measure is found to be ineffective, the plan must be adapted and implemented to incorporate new or additional management practices to meet standard conditions. Dischargers shall certify annually to the Regional Water Board individually or through an approved third party program that the plan is being implemented and is effectively protecting water quality, and report on progress in implementing site improvements intended to bring the site into compliance with all conditions of this Order."

Methods

The methods used to develop this WRPP include both field and office components. The office component consisted of reviewing available CGS Geomorphic Features Maps, Geology Maps, and historic aerial photos. The field component included identifying and accurately mapping all watercourses, wet areas, and wetlands located downstream of the cultivation areas, associated facilities, and all appurtenant roads accessing such areas. An accurate location of the Waters of the State is necessary to make an assessment of whether potential and existing erosion sites/pollution sites have the potential to discharge waste to an area that could affect waters of the State (including groundwater). Next, all cultivation areas, associated facilities, and all appurtenant roads accessing such areas were assessed for discharges and related controllable water quality factors from the activities listed in Order R1-2015-0023, Finding 4a-j. The field assessment also included an evaluation and determination of compliance with the Standard Conditions per Provision I.B of Order No. R1-2015-0023. The water resource protection plans required under Tier 2 are meant to describe the specific measures a discharger implements to achieve compliance with standard conditions. Therefore, all required components of the water resource protection plan per Provision I.B of Order No. R1-2015-0023 were physically inspected and evaluated. A comprehensive summary of each Standard Condition as it relates to the subject property is appended.

Summary of Standard Conditions Compliance

1. Site maintenance, erosion control, and drainage features Y/N
2. Stream crossing maintenance Y/N
3. Riparian and wetland protection and management Y/N
4. Spoils management Y/N
5. Water storage and use Y/N
6. Irrigation runoff Y/N
7. Fertilizers and soil amendments Y/N
8. Pesticides and herbicides? Y/N
9. Petroleum products and other chemicals Y/N
10. Cultivation-related wastes Y/N
11. Refuse and human waste Y/N

Identified Sites Requiring Remediation (See Standard Conditions Assessment)

Unique Map Point(s)	Map Point Description	Associated Standard Condition	Temporary BMP	Permanent BMP	Priority for Action	Time Schedule for completion of Permanent BMP	Completion Date
Map Point 1	Minor ditch erosion downslope of Map Point 1.	A(1)(b) A(1)(d) A(1)(e)	N/A	Install a 15 inch diameter, ditch relief culvert.	2	11/15/18	
Map Point 2	Runoff converges in inside ditch and flows over road fill above Class III watercourse.	A(1)(c) A(1)(d) A(3) A(4)	N/A	Deepen and rock line the inside ditch from the north end of the segment, to the Class III watercourse. The ditch shall be rock lined, "U" shaped, and wide enough to contain flows from expected runoff. Rock shall be large enough so that it remains in place during expected flows. Keep the outsloped road surface in place as it is. Install a rolling dip across the road surface approximately 20 to 30 feet north of the end of the road. Rock cobble shall be placed along the bottom of the fill slope off of the end of the road and may also be placed to fill in eroded gullies down the fill slope. This rock armoring may need to be placed by hand if equipment cannot reach, and to keep disturbance to a minimum.	2	11/15/18	

Identified Sites Requiring Remediation (See Standard Conditions Assessment)

Unique Map Point(s)	Map Point Description	Associated Standard Condition	Temporary BMP	Permanent BMP	Priority for Action	Time Schedule for completion of Permanent BMP	Completion Date
Map Point 2.5	Rock lined drainage ditch below "French Drain" Outlet	A(1)(d)	N/A	Monitor the site following prolonged precipitation. If erosion begins to take place, contact Timberland Resource Consultants to determine future erosion control measures.	2	Following heavy rains and prior to 11/15/18.	
Map Point 3	Additional ditch relief culvert needed to disperse flows prior to it reaching the watercourse	A(1)(d) A(1)(e)	N/A	Install a 15 inch diameter, ditch relief culvert	2	11/15/18	
Map Point 4.	Fill for a developed, cultivation area, toes out near the head of a small Class III watercourse.	A(1)(d) A(1)(e) A(3) A(4)	N/A	Install straw wattles or silt fencing around the toe of the fill. Apply grass seed and install erosion control netting or straw mulch to exposed soils. Monitor the fill slopes especially after heavy rainfall. If erosion or connectivity with the head of the Class III watercourse becomes apparent, contact Timberland Resource Consultants.	2	Upon receipt of this plan and prior to 11/15/18.	
Map Point 5	Road surface runoff drains easterly, at a natural low spot approximately 60 feet above the top of a Class III watercourse.	A(1)(d) A(1)(e)	N/A	Install a rolling dip in the road segment along Map Point 5.	2	11/15/18	
Map Point 6	Inside ditched road that is hydrologically connected to a Class III watercourse.	A(1)(d)	Maintain the straw wattles placed across this road surface to ensure that it continues to function as a temporary sediment trap for the remainder of this winter, as intended.	Deepen and rock line the existing inside ditch from the west end of the segment, to the Class III watercourse at the southeast end of the segment. The ditch shall be rock lined, "U" shaped, and wide enough to contain flows from expected runoff. Rock shall be large enough so that it remains stable and in place during expected flows. Monitor to ensure that reconstructed slopes are draining as expected.	2	11/15/18	
Map Point 7	Storm water runoff from around the developed area is hydrologically connected to a Class III watercourse during heavy rainfall.	A(1)(d) A(1)(e)	N/A	Maintain and monitor the storm drain and the culvert at Map Point 7 and the connected drainage downslope. If significant erosion or gulying begins to take place, contact Timberland Resource Consultants.	2	Following heavy rains and prior to 11/15/18.	
Map Point 8 and 9	Two old culverts located on the seasonal road that are not watercourse crossings nor are they ditch relief culverts.	A(2)	N/A	Maintain and keep open. Pry open the inlet. Cut off the crushed segment of culvert outlet at Map Point 8 and attach a downspout if necessary.	2	11/15/18	

Identified Sites Requiring Remediation (See Standard Conditions Assessment)

Unique Map Point(s)	Map Point Description	Associated Standard Condition	Temporary BMP	Permanent BMP	Priority for Action	Time Schedule for completion of Permanent BMP	Completion Date
Cultivation Soil Pile	Cultivation spoils carrying down the slope in runoff for approximately 300 feet.	A(4) A(7) A(10)	N/A	Cover pile with tarps, and surround with secured straw wattles. Alternatively, the Discharger could remove the pile to a more stable (level) location up on the developed portion of the property and keep covered during heavy rainfall.	2	11/15/18	
Shed "F"	Two gasoline storage tanks. One equipped with secondary containment, one without. Both tanks were located outside, unprotected from precipitation.	A(9)	N/A	Both fuel tanks shall be equipped with secondary containment, and a cover and side-wind protection throughout the rainy season.	2	11/15/18	

Treat Priority: Treatment Priority (1) indicates a very high priority with treatment being planned to occur immediately, (2) indicates a high priority site with treatment to occur prior to the start of the winter period (Nov. 15), (3) indicates a moderate priority with treatment being planned to occur within one year, or prior to the winter period (Nov. 15) of the 2nd season of operations, and (4) indicates a low priority with treatment being planned to occur in the shortest time possible, but no later than the expiration of this Order (five years).

Monitoring Plan

Tier 2 Dischargers shall include a monitoring element in the water resource protection plan that at a minimum provides for periodic inspection of the site, checklist to confirm placement and efficacy of management measures, and document progress on any plan elements subject to a time schedule. Tier 2 Dischargers shall submit an annual report (Appendix C) by March 31 of each year that documents implementation and effectiveness of management measures during the previous year. Tier 2 annual reporting is a function that may be provided through an approved third party program.

Monitoring of the site includes visual inspection and photographic documentation of each feature of interest listed on the site map, with new photographic documentation recorded with any notable changes to the feature of interest. At a minimum, all site features must be monitored annually, to provide the basis for completion of the annual re-certification process. Additionally, sites shall be monitored at the following times to ensure timely identification of changed site conditions and to determine whether implementation of additional management measures is necessary to iteratively prevent, minimize, and mitigate discharges of waste to surface water: 1) just prior to October 15 to evaluate site preparedness for storm events and storm water runoff, 2) following the accumulation of 3" total precipitation or by November 15, whichever is sooner, and 3) following any rainfall event with an intensity of 3" precipitation in 24 hours. Precipitation data can be obtained from the National Weather Service Forecast Office (e.g. by entering the zip code of the parcel location at <http://www.srh.noaa.gov/forecast>).

Inspection Personnel Contact Information:

Ron Pelletier
Timberland Resource Consultants
165 South Fortuna Blvd, Fortuna CA 95540
707-725-1897

Monitoring Plan Reporting Requirements

Order No. R1-2015-0023, Appendix C must be submitted to the Regional Water Board or approved third party program upon initial enrollment in the Order (NOI) and annually thereafter by March 31. Forms submitted to the Regional Water Board shall be submitted electronically to northcoast@waterboards.ca.gov. If electronic submission is infeasible, hard copies can be submitted to: North Coast Regional Water Quality Control Board, 5550 Skylane Boulevard, Suite A, Santa Rosa, CA 95403.

STATEMENT OF CONTINGENT AND LIMITING CONDITIONS CONCERNING THE PREPARATION AND USE OF WATER RESOURCE PROTECTION PLAN

Prepared by Timberland Resource Consultants

1. This Water Resource Protection Plan has been prepared for the property within APN 220-081-016 at the request of the discharger.
2. Timberland Resource Consultants does not assume any liability for the use or misuse of the information in this Water Resource Protection Plan.
3. The information is based upon conditions apparent to Timberland Resource Consultants at the time the inspection was conducted, and as disclosed to Timberland Resource Consultants by the landowner and / or the Discharger. Changes due to land use activities or environmental factors occurring after this inspection, have not been considered in this Water Resource Protection Plan.
4. Maps, photos, and any other graphical information presented in this report are for illustrative purposes. Their scales are approximate, and they are not to be used for locating and establishing boundary lines.
5. The conditions presented in this Water Resource Protection Plan may differ from those made by others or from changes on the property occurring after the inspection was conducted. Timberland Resource Consultants does not guarantee this work against such differences.
6. Timberland Resource Consultants did not conduct an investigation on a legal survey of the property.
7. Persons using this Water Resource Protection Plan are advised to contact Timberland Resource Consultants prior to such use.
8. Timberland Resource Consultants will not discuss this report or reproduce it for anyone other than the Client named in this report without authorization from the Client.



Ron Pelletier
Timberland Resource Consultants

Water Resource Protection Plan

General Location Map - WDID1B16459CHUM

NORTH

Map Scale 1 inch = 2,000 feet
Section 21, T4S, R2E, HB&M
Briceland USGS 7.5' Quad, C.I. = 40 feet

 Property Boundary

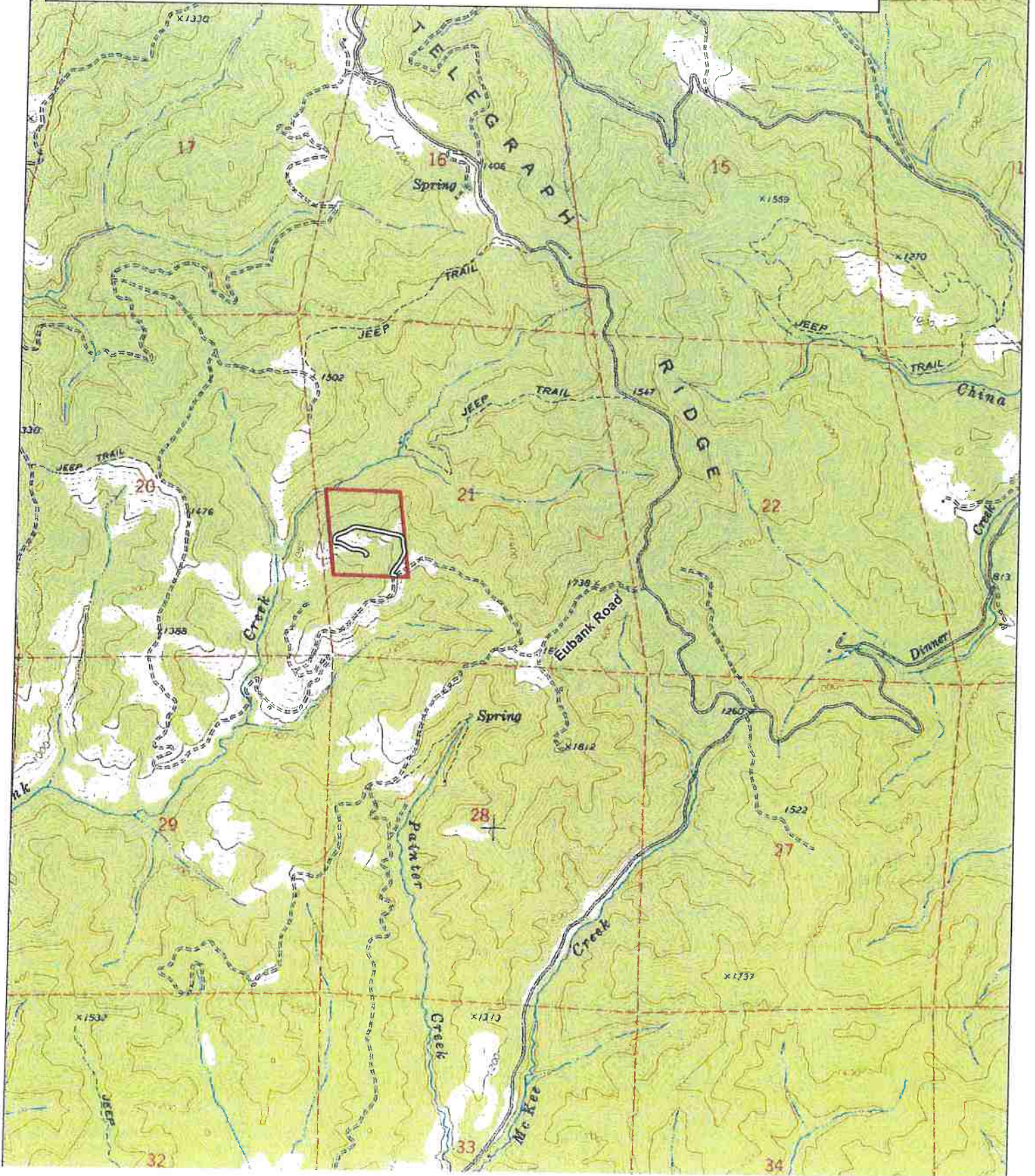

Water Resource Protection Plan

WRPP Map - WDID1B16459CHUM



Map Scale 1 inch = 200 feet
 APN 220-081-016 - Section 21, T4S, R2E, H8&M
 Brceland USGS 7.5' Quad. C. I. = 40 feet

- | | | | | | |
|--|-----------------------|--|---|--|--|
| | Property Boundary | | Garage / Shop | | Developed Areas |
| | Rocked Roads | | Shed (G = Generator Shed
F = Fuel Shed) | | Cultivation Soil Pile |
| | Seasonal Roads | | House | | Cultivation Soil Carried
In Runoff |
| | ATV Trail | | Solar Panel | | Map Points
(E) DRC = Existing Ditch
Relief Culvert |
| | Bank Seep / Spring | | 60' x 25' Cement Foundation
(Under Construction) | | Storm Drain Drop Inlets |
| | Class III Watercourse | | Cultivation - Greenhouse | | Storm Drain Outlet |
| | Class II Watercourse | | Cultivation - Outdoor | | Potential Connected Road /
Development Drainage |
| | Multi Water Tanks | | | | |
| | Water Tank | | | | |
| | POD | | | | |
| | Well | | | | |

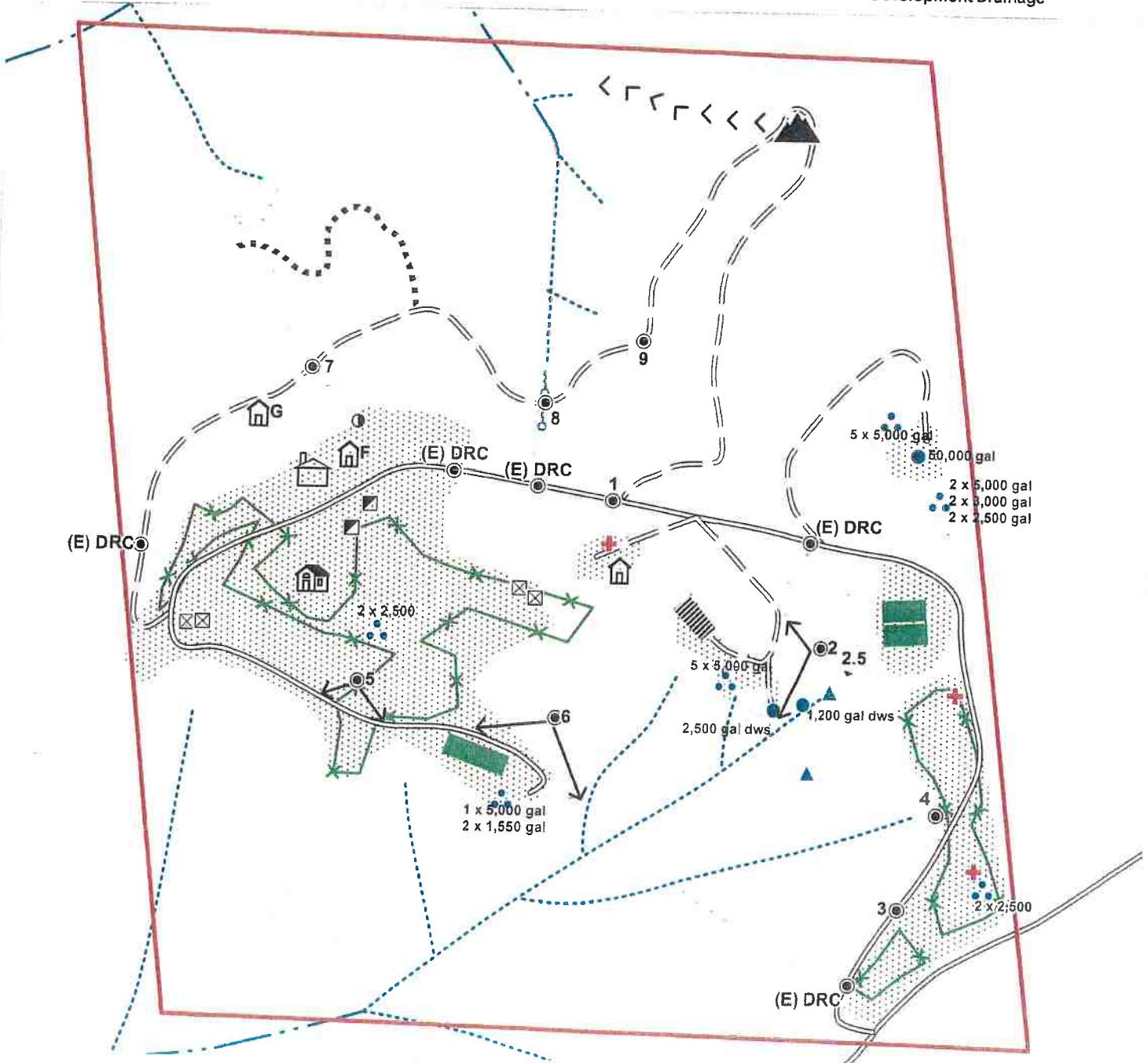

Water Resource Protection Plan

WRPP Map - W DID1B16459CHUM



Map Scale 1 inch = 200 feet
 APN 220-081-016 - Section 21, T4S, R2E, HB&M
 Briceland USGS 7.5' Quad, C.I. = 40 feet

- | | | | | | |
|--|-----------------------|--|---|--|--|
| | Property Boundary | | Garage / Shop | | Developed Areas |
| | Rocked Roads | | Shed (G = Generator Shed
F = Fuel Shed) | | Cultivation Soil Pile |
| | Seasonal Roads | | House | | Cultivation Soil Carried
In Runoff |
| | ATV Trail | | Solar Panel | | Map Points
(E) DRC = Existing Ditch
Relief Culvert |
| | Bank Seep / Spring | | 60' x 25' Cement Foundation
(Under Construction) | | Storm Drain Drop Inlets |
| | Class III Watercourse | | Cultivation - Greenhouse | | Storm Drain Outlet |
| | Class II Watercourse | | Cultivation - Outdoor | | Potential Connected Road /
Development Drainage |
| | Multi Water Tanks | | | | |
| | Water Tank | | | | |
| | POD | | | | |
| | Well | | | | |

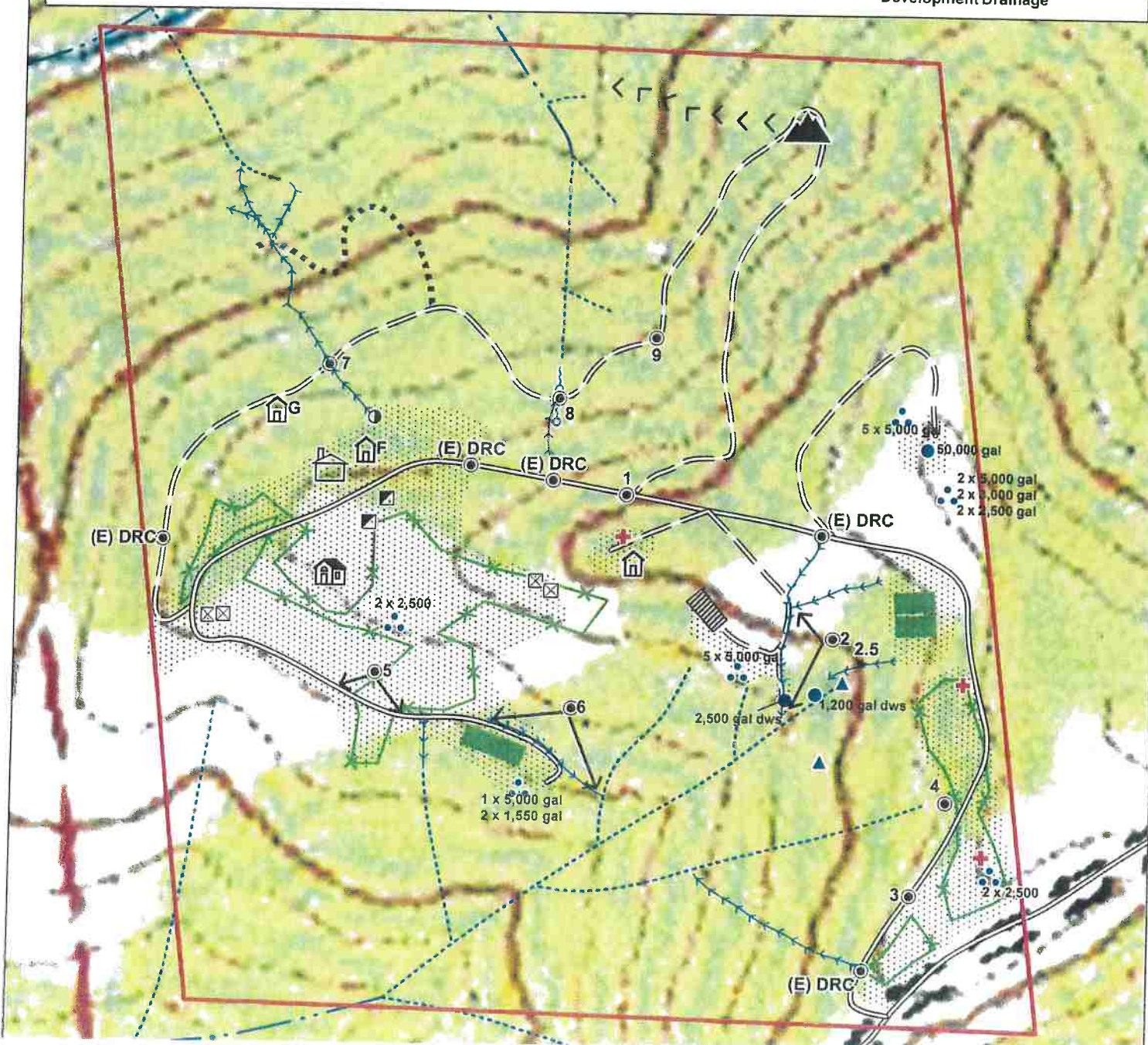

























Water Resource Protection Plan

WRPP Map - WDID1B16459CHUM

NORTH

Map Scale 1 inch = 200 feet
 APN 220-081-016 - Section 21, T4S, R2E, HB&M
 Brice land USGS 7.5' Quad C.1. = 40 feet

- | | | | | | |
|---|-----------------------|---|---|---|--|
|  | Property Boundary |  | Garage / Shop |  | Developed Areas |
|  | Rocked Roads |  | Shed (G = Generator Shed
F = Fuel Shed) |  | Cultivation Soil Pile |
|  | Seasonal Roads |  | House |  | Cultivation Soil Carried
In Runoff |
|  | ATV Trail |  | Solar Panel |  | Map Points
(E) DRC = Existing Ditch
Relief Culvert |
|  | Bank Seep / Spring |  | 60' x 25' Cement Foundation
(Under Construction) |  | Storm Drain Drop Inlets |
|  | Class III Watercourse |  | Cultivation - Greenhouse |  | Storm Drain Outlet |
|  | Class II Watercourse |  | Cultivation - Outdoor |  | Potential Connected Road /
Development Drainage |
|  | Multi Water Tanks | | | | |
|  | Water Tank | | | | |
|  | POD | | | | |
|  | Well | | | | |



Water Resource Protection Plan
Assessment of Standard Conditions
for
APN 220-081-016 - WDID #1B16459CHUM

A. Standard Conditions, Applicable to All Dischargers

1. Site maintenance, erosion control and drainage features: In compliance? Y /N (see b, c, d, and e. below)
- a. Roads shall be maintained as appropriate (with adequate surfacing and drainage features) to avoid developing surface ruts, gullies, or surface erosion that results in sediment delivery to surface waters.

The access roads on the property have adequate surfacing and were not rutting on the date of the assessment. The road on the property that accesses the house and much of the property is rocked. Other roads on the property shown as seasonal roads or an ATV trail also have adequate surfacing for their use and were free of ruts, gullies, and surface erosion. Road surfaces on the property are currently in compliance with this standard condition.

- b. Roads, driveways, trails, and other defined corridors for foot or vehicle traffic of any kind shall have adequate ditch relief drains or rolling dips and/or other measures to prevent or minimize erosion along the flow paths and at their respective outlets

In order to minimize minor erosion of a short section of inside ditch and eliminate potential connectivity, a ditch relief culvert shall be installed at Map Point 1 as shown on the WRPP Map. This location is near the top of a grade of road that currently has two existing ditch relief culverts downslope. Installation of a ditch relief culvert at Map Point 1 will reduce the volume of ditch drainage currently draining at the first existing ditch relief culvert located westerly of Map Point 1, and eliminate potential connectivity downslope of the existing ditch relief culvert draining towards Map Point 8 on the WRPP Map.

Other than this location, roads on the property have adequate drainage features to minimize and prevent erosion along inside ditches and at outlets. With the installation of a ditch relief culvert at Map Point 1, roads on the property will be in compliance with this standard condition. Discharger is aware of the normal road maintenance required to keep his roads open and from becoming degraded.

- c. Roads and other features shall be maintained so that surface runoff drains away from potentially unstable slopes or earthen fills. Where road runoff cannot be drained away from an unstable feature, an engineered structure or system shall be installed to ensure that surface flows will not cause slope failure.

Physical reconnaissance of the property revealed no unstable areas per 14CCR 895.1. Developed areas and cultivation areas are located along existing roads that tend to follow the ridgetops. Slopes in the vicinity of the developed areas and cultivation areas for the most part are gentle. Some of the developed areas have been graded on slopes 30% to 40%. Steeper slopes on the property are undeveloped, timbered and vegetated.

Although unstable areas were not identified, this property is not in full compliance with this standard condition because there is one location where runoff is being directed towards earthen fill. This is shown on the WRPP Map. Road / Development Drainage collects in an inside ditch shown as Map Point 2, and is eroding over a small constructed pad at the south end of the road where a water tank is located. The tank is shown as “2,500 gal dws” on the WRPP Map. Runoff is currently eroding over the earthen fill at the end of the road and is connected to the Class III watercourse. This current situation is not in compliance with Standard Condition A.1.d. below. A description and a feasible remedy are described in detail below, under Standard Condition A.1.d.

- d. Roads, clearings, fill prisms, and terraced areas (cleared/developed areas with the potential for sediment erosion and transport) shall be maintained so that they are hydrologically disconnected¹, as feasible, from surface waters, including wetlands, ephemeral, intermittent and perennial streams.

¹ Connected roads are road segments that deliver road surface runoff, via the ditch or road surface, to a stream crossing or to a connected drain that occurs within the high delivery potential portion of the active road network. A connected drain is defined as any cross-drain culvert, water bar, rolling dip, or ditch-out that appears to deliver runoff to a defined channel. A drain is considered connected if there is evidence of surface flow connection from the road to a defined channel or if the outlet has eroded a channel that extends from the road to a defined channel. (http://www.forestsandfish.com/documents/Road_Mgmt_Survey.pdf)

There are eight locations where roads and / or developed areas on the property are potentially hydrologically connected to Class III watercourses. These are identified on the WRPP Map as Map Points 1 through 7. Each of these situations along with feasible remedies are described below. Because of the identified potential connectivity, this property is not in compliance with this standard condition.

Map Point 1: Map Point 1 is the location for a proposed ditch relief culvert installation. There is currently an existing, functioning ditch relief culvert located along this segment of road, westerly of Map Point 1. Upon inspection of the outlet of the existing ditch relief culvert, a narrow, potentially connected drainage channel had recently formed. It appeared to be from the recent heavy rainfall that had just occurred in October, 2016. The recently formed connected drainage extends downslope for approximately 100 feet and deposits onto and over the road surface near Map Point 8 on the WRPP Map. In order to reduce the volume of ditch runoff draining from the existing ditch relief culvert, west of Map Point 1, the Discharger shall install a 15 inch diameter, ditch relief culvert at the location shown as Map Point 1 on the WRPP Map. This is expected to evenly disperse ditch runoff prior to it extending downslope and potentially connecting with a watercourse below.

Map Point 2: Map Point 2 is a segment of road of approximately 150 feet in length. Runoff originating from an existing ditch relief culvert and from a developed, cultivation area upslope, converge at the north end of the road segment shown as Map Point 2. During rain storms, runoff is carried southerly in the inside ditch to the end of the road where it drains into the Class III watercourse. The road is slightly outsloped along this segment so surface drainage does not contribute to the volume of flow in the ditch. During heavy rain storms, runoff escapes the ditch and flows over erodible fills at the end of the road, directly above the Class III watercourse. The Discharger has recently installed erosion control netting on the slope of the fill off of the end of

the road, and has rock lined the inside ditch along the area shown as Map Point 2. The Discharger has also rock lined the road and development drainage channels that lead to the inside ditch from above.

The most feasible mitigation for the connected road segment at Map Point 2 is to deepen and rock line the existing inside ditch from the north end of the segment, to the Class III watercourse at the south end of the segment. At the south end of this road segment, an inside ditch shall be constructed along the base of the existing cut bank, and continue southerly to the Class III watercourse. The ditch shall be rock lined, "U" shaped, and wide enough to contain flows from expected runoff. Rock shall be large enough so that it remains stable and in place during expected flows. The ditch shall be used to drain the runoff from above. The slightly outsloped road surface shall remain as it is. A rolling dip shall be installed across the road surface approximately 20 to 30 feet north of the end of the road. This will be done to drain the road surface westerly away from the erodible fills off of the end of the road. Rock cobble shall be placed along the bottom of the fill slope off of the end of the road to armor the base. Rock armor may also be placed to fill in eroded gullies that had formed down the fill slope prior to the placement of the erosion control jute netting. This rock armoring may need to be placed by hand if equipment cannot reach, and to keep disturbance to a minimum. Grass and vegetation have begun to become established on the fill slope off of the end of the road. Leave as much of this vegetation intact as possible. Although this will not result in a hydrologic disconnection, it is the most feasible option for mitigating hydrologic connectivity and keeping runoff from eroding fills off of the end of the road.

Map Point 2.5: Map Point 2.5 is a recently rock lined drainage channel that extends from the outlet of a "French Drain" that exists under the developed cultivation area. The rock lined drainage extends downslope for approximately 100 feet and ends just above the head of a Class III watercourse. The areas adjacent to the rock lined channel has been lined with "jute" netting and covered with straw. The application of rock to the drainage ditch and the adjacent erosion control had just recently been installed prior to the site visit on 12/2/16. No erosion was observed at the site, but it had not yet experienced prolonged, heavy precipitation. The site is mapped and was designated as Map Point 2.5 on the WRPP Map. Future monitoring of the site shall take place following periods of prolonged precipitation to determine if erosion is occurring to the area, especially between the bottom of the rock lined drainage and the top of the Class III watercourse. If erosion begins to take place, the Discharger shall contact Timberland Resource Consultants to determine future erosion control measures to be taken.

Map Point 3: Map Point 3 is the location for a proposed ditch relief culvert installation. There is currently an existing, functioning ditch relief culvert located along this segment of road, southwesterly of Map Point 3. Upon inspection of the outlet of the existing ditch relief culvert, a narrow, connected drainage channel had recently formed through the duff and a very shallow layer of soil. It appeared to be from the recent heavy rainfall that had just occurred in October, 2016. The recently formed connected drainage extends and meanders downslope for approximately 300 feet to the small Class III watercourse below. In order to reduce the volume of runoff draining from the existing ditch relief culvert near the southeastern corner of the property, the Discharger shall install a 15 inch diameter, ditch relief culvert at the location shown as Map Point 3 on the WRPP Map. This is expected to evenly disperse ditch runoff prior to it reaching the Class III watercourse below.

Map Point 4: At this location, recently placed fill for a developed cultivation area, toes out near the head of a small Class III watercourse. The fill face at Map Point 4 was in the process of being armored with rock on the date of the assessment. Minor surface erosion occurred over these recently placed fills during recent heavy rainfall in October, 2016, prior to the placement of the rock armor. Because of the recent fills and ongoing rock armoring at Map Point 4, combined with the recent rainfall, hydrologic connectivity between the fills and the upper extent of the Class III watercourse was difficult to determine following one site visit. Given its close proximity, the Discharger shall install erosion control measures to the fill face at Map Point 4. Install straw wattles or silt fencing around the toe of the fill. Apply grass seed and install erosion control netting or straw mulch to exposed soils on the fresh fill face at Map Point 4. Also monitor the fill slopes at Map Point 4, especially after periods of heavy rainfall. If erosion or connectivity with the head of the Class III watercourse becomes apparent, the Discharger shall contact Timberland Resource Consultants.

Map Point 5: The road segment identified as Map Point 5 is approximately 120 feet in length in which surface runoff from the road, drains off of the road easterly, at a natural low spot that is approximately 60 feet above the top of a Class III watercourse. This area is shown as Map Point 5 on the WRPP Map. Although it does not appear to be a significant source of sediment, it is a hydrologically connected road segment. The road surface along this segment is rocked and is not rutting. In order to reduce the amount of road runoff that drains to the head of the Class III watercourse, the Discharger shall install a rolling dip in the road segment identified as Map Point 5. This is expected to significantly reduce the amount of road surface runoff reaching the Class III watercourse southeast of Map Point 5.

Map Point 6: This is a segment of a road and cultivation area that is hydrologically connected to a Class III watercourse via an inside ditch. The segment of road with inside ditch is approximately 100 feet long and the connected ditch beyond the end of the road is approximately 50 to 60 feet. The last 50 to 60 feet appears to be located on a historic logging skidtrail down to the Class III watercourse. The upper length of inside ditch beyond the end of the road appears to have been lined with rock in the past. A gully has now formed along the lower end of this connected drainage. This connected ditch is also transporting sediment from the outdoor cultivation area above the road between Map Points 5 and 6. Runoff from recent heavy rainfall deposits sediment from this terraced cultivation area down onto the road surface and inside ditch along the segment shown as Map Point 6. The terraced slopes above the road between Map Points 5 and 6 have begun to slump. The Discharger has covered these developed, terraced slopes with plastic and tarps to protect them from precipitation and more slumping. This does protect the slopes but leads to more runoff into the ditch at Map Point 6 during rains.

The Discharger has hired an engineer and an experienced operator to plan, permit, and reconfigure the slumping developed, terraced slopes, and to improve drainage between Map Points 5 and 6. In general, the reconfiguration of the slopes will involve re-contouring and reducing the eastern extent of the terraced area above the road between Map Points 5 and 6. Rock armoring of cut banks and fill slopes may take place if necessary, as determined by the engineer or the operator. Erosion control netting, grass seed, and straw wattles will be installed on bare soils. Green houses will be rain guttered and piped off of the terrace surfaces. Drainage will be incorporated into these reconstructed terrace slopes in the form of gently out sloping of the terrace surfaces. Construction of rock lined drainage ditches may be incorporated into these re-configured terrace slopes at locations to be determined by the engineer. The Discharger, the engineer, and the operator are all aware of the Order and the need to reduce sediment and disperse runoff. As a temporary mitigation, the Discharger has recently installed approximately

20 evenly spaced straw wattles across the road along the segment shown as Map Point 6 to act as a sediment trap.

The most feasible mitigation for the connected inside ditch segment shown as Map Point 6 is to deepen and rock line the existing inside ditch from the west end of the segment, to the Class III watercourse at the southeast end of the segment. The ditch shall be rock lined, "U" shaped, and wide enough to contain flows from expected runoff. Rock shall be large enough so that it remains stable and in place during expected flows. Although this does not result in a hydrologic disconnection, it is the most feasible option for mitigation at this particular site. Installation of cross drains along this segment are not being proposed because of existing infrastructure below the road and it is unlikely that runoff could be successfully dispersed prior to joining with other Class III watercourses located downslope to the south. The Discharger shall monitor the terraced slopes between Map Points 5 and 6 upon conclusion of the proposed reconstruction work that was described above, to ensure that area is draining as expected.

Map Point 7: Storm water runoff originating from above, is conveyed across the seasonal road via a 24 inch diameter culvert shown at Map Point 7. Storm water runoff from around the developed area surrounding the house, a graded parking area, and terraced slopes are originally collected by two storm drain drop inlets and connected via an underground culvert that outlets northeast of the fuel storage shed. The storm drains, their outlet, and the connected road and development drainage, as well as the culvert at Map Point 7 are all shown on the WRPP Map. This drainage infrastructure was planned and installed along with the development of the house site on this property approximately 6 to 8 years ago. Drainage from the storm drain outlet is not eroding. It flows over a heavily rock armored cut bank face above the 24 inch diameter culvert inlet at Map Point 7. Energy dissipation boulders were placed below the outlet at the time of its installation. Erosion is not occurring at Map Point 7.

The drainage below Map Point 7 was followed out and mapped to assess for connectivity with a watercourse. The drainage below Map Point 7 can be followed as it continues downslope through the duff and a shallow layer of soil. It appeared to have been freshly uncovered during the recent heavy rainfall that had just occurred in October, 2016, and may not have been detectable prior to October, 2016. The recently formed, connected drainage extends for approximately 200 feet downslope, where slopes become more gradual on a bench near the end of an old skid trail. Once on the benching slopes, the drainage begins to divide and disperse. However, at least one of the small channels appeared capable of remaining intact and continuous downslope for approximately 100 more feet, to a small Class III watercourse, during periods of heavy rainfall.

The connected road and development drainage is only connected to the small Class III watercourse during periods of heavy rainfall, and when it is connected, the volume of water is far less than what occurs upslope at the culvert outlet at Map Point 7. The storm drain outlet and the culvert at Map Point 7 are kept maintained and did not appear to be sources of sediment. Downslope of Map Point 7, the area is tree covered and vegetated, and the connected drainage does not flow across erodible fills and is not causing significant erosion. The source of the connected drainage is the storm drainage infrastructure that was planned and installed around the developed house site area 6 to 8 years ago. Although hydrologically connected during heavy rainfall, significant erosion was not taking place. Further mitigation downslope of Map Point 7 is not feasible and would not necessarily result in a disconnection during heavy rainfall. The Discharger shall continue to maintain and monitor the storm drain and the culvert at Map Point 7. Also monitor the connected drainage downslope of Map Point 7, especially after periods of

heavy rainfall. If significant erosion or gulying begins to take place, the Discharger shall contact Timberland Resource Consultants.

- e. Ditch relief drains, rolling dip outlets, and road pad or terrace surfaces shall be maintained to promote infiltration/dispersal of outflows and have no apparent erosion or evidence of soil transport to receiving waters.

There are four locations identified on the property where ditch relief drains, rolling dip outlets, and road or terrace surfaces have evidence of soil transport to small Class III watercourses on the property. These have been discussed above in Standard Condition A.1.d, and are identified as Map Points 1, 3, 4, 5, and 7. Each of these situations along with feasible remedies are described above. Because of these identified locations, this property is not in compliance with this standard condition. Other than these specific locations, roads and developed areas on the property are adequately maintained to promote dispersal of outflows and have no apparent erosion or soil transport to receiving waters. The Discharger is aware of the normal maintenance of road drainage features required to keep them functioning properly and from causing erosion.

- f. Stockpiled construction materials are stored in a location and manner so as to prevent their transport to receiving waters.

In compliance at this time. In the future, all construction materials will be stored to prevent their transport to receiving waters.

2. Stream Crossing Maintenance: **In compliance?** Y /N

- a. Culverts and stream crossings shall be sized to pass the expected 100-year peak streamflow.
 b. Culverts and stream crossings shall be designed and maintained to address debris associated with the expected 100-year peak streamflow.
 c. Culverts and stream crossings shall allow passage of all life stages of fish on fish-bearing or restorable streams, and allow passage of aquatic organisms on perennial or intermittent streams.
 d. Stream crossings shall be maintained so as to prevent or minimize erosion from exposed surfaces adjacent to, and in the channel and on the banks.
 e. Culverts shall align with the stream grade and natural stream channel at the inlet and outlet where feasible.²
 f. Stream crossings shall be maintained so as to prevent stream diversion in the event that the culvert/crossing is plugged, and critical dips shall be employed with all crossing installations where feasible.³

²At a minimum, the culvert shall be aligned at the inlet. If infeasible to align the culvert outlet with the stream grade or channel, outlet armoring or equivalently effective means may be applied.

³If infeasible to install a critical dip, an alternative solution may be chosen.

There are no watercourse crossings therefore this property is in compliance with this Standard Condition. There are two old culverts located on the seasonal road that appear to have been in place for a long time. These are not watercourse crossings nor are they ditch relief culverts. Nonetheless, they were assessed and are being described in this section of the report. These are shown as Map Points 8 and 9 on the WRPP Map. Map Point 8 is a 15 inch diameter metal culvert that appears to have been installed many years ago to drain a small bank seep / spring. It is functioning, but the inlet is partially crushed. The outlet appears to have been elongated and is now crushed. The Discharger has recently hand dug out a small 5 foot by 5 foot basin at the inlet. The Discharger shall pry open the inlet, cut off the crushed segment of culvert at the

outlet and attach a downspout if necessary. Installation of the ditch relief culvert at Map Point 1 on the road above will relieve the amount of drainage flowing onto the road adjacent to Map Point 8 during heavy rainfall.

The culvert at Map Point 9 is a 15 inch diameter metal culvert that has also been in place for a long time. It is located in a draw that is upslope from the top of a Class III watercourse. The draw at the culvert location doesn't appear to have had flowing water for a very long time, even during the recent heavy rainfall of October, 2016. It is in need of maintenance at the inlet.

3. Riparian and Wetland Protection and Management: In compliance? Y /N (see below)
- a. For Tier 1 Dischargers, cultivation areas or associated facilities shall not be located within 200 feet of surface waters. While 200 foot buffers are preferred for Tier 2 sites, at a minimum, cultivation areas and associated facilities shall not be located or occur within 100 feet of any Class I or II watercourse or within 50 feet of any Class III watercourse or wetlands. The Regional Water Board or its Executive Officer may apply additional or alternative⁴ conditions on enrollment, including site-specific riparian buffers and other BMPs beyond those identified in water resource protection plans to ensure water quality protection.
 - b. Buffers shall be maintained at natural slope with native vegetation.
 - c. Buffers shall be of sufficient width to filter wastes from runoff discharging from production lands and associated facilities to all wetlands, streams, drainage ditches, or other conveyances.
 - d. Riparian and wetland areas shall be protected in a manner that maintains their essential functions, including temperature and microclimate control, filtration of sediment and other pollutants, nutrient cycling, woody debris recruitment, groundwater recharge, streambank stabilization, and flood peak attenuation and flood water storage.

⁴Alternative site-specific riparian buffers that are equally protective of water quality may be necessary to accommodate existing permanent structures or other types of structures that cannot be relocated.

The current cultivation areas are located mostly up on major ridgetops or just off. The nearest cultivation areas are 60 to 65 feet from Class III watercourses, and hundreds of feet from the nearest Class II watercourses. With the exception of two locations described below, Map Point 2 and Map Point 4, buffers are undeveloped and heavily vegetated with native trees and brush and are sufficiently wide enough to filter any discharges from production lands. In order to gain compliance with the Order, riparian buffers shall be excluded from operations and protected in a manner that maintains their essential functions.

Map Point 2: The south end of the Map Point 2 segment is an area where road fill extends into the 50 foot wide Class III buffer. During rain storms, runoff is carried southerly in the inside ditch to the end of the road where it drains into the Class III watercourse. During heavy rain storms, runoff escapes the ditch and flows over the road fill that ends directly above the Class III watercourse. This is currently not in compliance with Standard Condition A.3.b. and c. above. In addition to the Map Point 2 mitigations provided previously in this report, riparian buffers shall be excluded from operations and protected in a manner that maintains their essential functions. The Discharger has recently installed erosion control netting on the face of the fill off of the end of the road that extends into the buffer. See the previous mitigation for Map Point 2 discussed in Standard Condition A.1.d above.

Map Point 4: At this location, recently placed fill for a developed, cultivation area, toes out near the head of a small Class III watercourse. The fill face at Map Point 4 was in the process of being armored with rock on the date of the assessment. Because of the recent fills and ongoing rock armoring at Map Point 4, combined with the recent rainfall, the upper extent of the Class III watercourse was difficult to determine following one site visit. The cultivation area itself is not within the 50 foot wide Class III buffer, but the bottom half of the recent fills may be. In addition to the Map Point 4 mitigations provided previously in this report, riparian buffers shall be excluded from operations and protected in a manner that maintains their essential functions. See the previous mitigation for Map Point 4 discussed in Standard Condition A.1.d above.

4. Spoils Management: In compliance? Y/N (see below)

- a. Spoils⁵ shall not be stored or placed in or where they can enter any surface water.
- b. Spoils shall be adequately contained or stabilized to prevent sediment delivery to surface waters.
- c. Spoils generated through development or maintenance of roads, driveways, earthen fill pads, or other cleared or filled areas shall not be sidecast in any location where they can enter or be transported to surface waters.

⁵ Spoils are waste earthen or organic materials generated through grading or excavation, or waste plant growth media or soil amendments. Spoils include but are not limited to soils, slash, bark, sawdust, potting soils, rock, and fertilizers.

There are two locations, Map Points 2 and 4, where road and terrace fills were previously placed that have access to Class III watercourses. Descriptions of these sites, and measures to stabilize these fill slopes are included in Standard Conditions A.1.d. and A.3. above.

A large cultivation spoils pile is located near the northeast corner of the property that is not in compliance this Standard Condition. It is located on the inside turn of a switchback, far from watercourses, on gentle to moderate slopes that appear to be adequate to contain the spoils. However, during the heavy rainfall in October, 2016, this pile became saturated. Runoff coming from the pile, mixed with road runoff, drain across the road in a small waterbreak. Upon assessment of the area below the road, cultivation spoils were found to be carrying down the slope in runoff for approximately 300 feet. It was not accessing a watercourse during the assessment, but if left untreated, could potentially. The Discharger shall contain this pile by covering it with tarps, and surrounding it with secured straw wattles. Alternatively, the Discharger could remove the pile to a more stable location up onto the developed portion of the property and keep it covered during periods of rainfall.

5. Water Storage and Use: In compliance? Y/N

- a. Size and scope of an operation shall be such that the amount of water used shall not adversely impact water quality and/or beneficial uses, including and in consideration with other water use by operations, instream flow requirements and/or needs in the watershed, defined at the scale of a HUC-12⁶ watershed or at a smaller hydrologic watershed as determined necessary by the Regional Water Board Executive Officer.
- b. Water conservation measures shall be implemented. Examples include use of rainwater catchment systems or watering plants with a drip irrigation system rather than with a hose or sprinkler system.
- c. For Tier 2 Dischargers, if possible, develop off-stream storage facilities to minimize surface water diversion during low flow periods.
- d. Water is applied using no more than agronomic rates.⁷
- e. Diversion and/or storage of water from a stream should be conducted pursuant to a valid water right and in compliance with reporting requirements under Water Code section 5101.

- f. Water storage features, such as ponds, tanks, and other vessels shall be selected, sited, designed, and maintained so as to insure integrity and to prevent release into waters of the state in the event of a containment failure.

⁶See definition and link to maps at: <http://water.usgs.gov/GIS/huc.html>

⁷"Agronomic rates" is defined as the rates of fertilizer and irrigation water that a plant needs to enhance soil productivity and provide the crop or forage growth with needed nutrients for optimum health and growth, without having any excess water or nutrient percolate beyond the root zone.

Water Use and Storage: The landowner has three permitted wells, which are plumbed to twenty-five hard plastic tanks (90,000 gallons of total storage capacity) located throughout the property that are dedicated to agriculture. There is also a 50,000 gallon pioneer tank that is dedicated to domestic use. The Streambed Alteration Notification recently submitted to CDFW stated the following: the landowner presently has 57,100 ft² of existing cultivation consisting of 20,500 ft² mixed light, 1,800 ft² indoor and 34,800 ft² outdoor. At 1.4 gallons of water per 10 ft² for the outdoor and 0.75 gallons of water per 10 ft² for the mixed light, total water use is approximately 8,000 gallons of water per day. The Discharger indicated that in the future total cultivation area on the property will be approximately 30,000 square feet.

There are two existing diversions from a springs located at the head of a Class III watercourse that is tributary to Eubank Creek. The northern diversion works is a wooden spring box approximately 2.5 feet square and 1 foot deep. Diverted water is gravity fed via ¾-inch poly pipe down to a 2,500 gallon tank. The recently submitted Streambed Alteration Notification proposes to allow direct diversion for domestic use only at 200 gallons of water per day. The second diversion works is located approximately 100 feet to the south. It is a 6 inch perforated plastic pipe of unknown length that is situated horizontally into the side of the hill in a shallow depression. It is going to be added to the recently submitted Streambed Alteration Notification.

Water storage and use on the property is in compliance with the Standard Conditions 5, a – f. The size of the operation does not appear excessive to a point of adversely impacting water quality and/or beneficial uses. The Discharger uses three separate wells on the property and will follow the conditions of his approved CDFW Streambed Alteration Agreement. The discharger uses mulch extensively and meters water at the hose to ensure over watering does not take place. As stated above, surface water diversions are used for domestic uses only. Well water is used for irrigation. Surface water diversions are not used for irrigation. Irrigation is applied at an agronomic rate. Surface diversion of water from a stream, when taking place, are conducted in compliance with reporting requirements under Water Code section 5101, and a recently submitted CDFW Streambed Alteration Notification. Water storage tanks are situated on constructed flats on or near ridgetops far from watercourses that are stable and level.

6. Irrigation Runoff: In compliance? Y /N

Implementing water conservation measures, irrigating at agronomic rates, applying fertilizers at agronomic rates and applying chemicals according to the label specifications, and maintaining stable soil and growth media should serve to minimize the amount of runoff and the concentration of chemicals in that water. In the event that irrigation runoff occurs, measures shall be in place to treat/control/contain the runoff to minimize the pollutant loads in the discharge. Irrigation runoff shall be managed so that any entrained constituents, such as fertilizers, fine sediment and suspended organic particles, and other oxygen consuming materials are not discharged to nearby watercourses. Management practices include, but are not limited to, modifications to irrigation systems that reuse tailwater by constructing off-stream retention basins, and active (pumping) and or passive (gravity) tailwater recapture/redistribution systems. Care shall

be taken to ensure that irrigation tailwater is not discharged towards or impounded over unstable features or landslides.

In compliance at this time. The Discharger irrigates at an agronomic rate that does not result in runoff. This combined with the proximity of the cultivation area from the watercourse, ensures there is little to no chance for any irrigation runoff to reach surface waters.

7. Fertilizers and Soil Amendments: Y /N (see below)

- a. Fertilizers, potting soils, compost, and other soils and soil amendments shall be stored in locations and in a manner in which they cannot enter or be transported into surface waters and such that nutrients or other pollutants cannot be leached into groundwater.
- b. Fertilizers and soil amendments shall be applied and used per packaging instructions and/or at proper agronomic rates.
- c. Cultivation areas shall be maintained so as to prevent nutrients from leaving the site during the growing season and post-harvest.

The cultivation spoils pile that is located near the northeast corner of the property is not currently in compliance with this Standard Condition or Standard Condition A(4) as discussed previously in this report. As stated above, this pile needs to be tarped and surrounded by straw wattles or removed to a more stable location.

With the exception of this one location, the rest of the property is in compliance with this Standard Condition. The Discharger keeps bagged, boxed, and bottles of fertilizers and amendments in a large garage or storage sheds on the property. With the exception of the cultivation spoils pile discussed above, spent growth spoils remain on the immediate cultivation areas and are amended for reuse at the beginning of the growing season. Fertilizers and soil amendments are applied per packaging instructions and at agronomic rates. Fertilizing at agronomic rates will help to prevent nutrients from leaving the site during, and after the growing season. Cultivation areas are level and most soils were contained in pots or planter boxes. Other than the site discussed above, no areas were found where cultivation soils were leaving the site in runoff.

8. Pesticides/Herbicides: In compliance? Y /N

At the present time, there are no pesticides or herbicides registered specifically for use directly on cannabis and the use of pesticides on cannabis plants has not been reviewed for safety, human health effects, or environmental impacts. Under California law, the only pesticide products not illegal to use on cannabis are those that contain an active ingredient that is exempt from residue tolerance requirements and either registered and labeled for a broad enough use to include use on cannabis or exempt from registration requirements as a minimum risk pesticide under FIFRA section 25(b) and California Code of Regulations, title 3, section 6147. For the purpose of compliance with conditions of this Order, any uses of pesticide products shall be consistent with product labeling and any products on the site shall be placed, used, and stored in a manner that ensures that they will not enter or be released into surface or ground waters.

The Discharger does not use any chemical pesticides and herbicides. If needed in the future, pesticide or herbicide use on the property will be all natural, organic ingredients. Any pesticide products used on this property in the future shall be consistent with product labelling, and used and stored in a manner that ensures that they will not enter or be released into the surface or ground waters.

9. Petroleum products and other chemicals: **In compliance?** Y /N (see below)

- a. Petroleum products and other liquid chemicals, including but not limited to diesel, biodiesel, gasoline, and oils shall be stored so as to prevent their spillage, discharge, or seepage into receiving waters. Storage tanks and containers must be of suitable material and construction to be compatible with the substance(s) stored and conditions of storage such as pressure and temperature.
- b. Above ground storage tanks and containers shall be provided with a secondary means of containment for the entire capacity of the largest single container and sufficient freeboard to contain precipitation.
- c. Dischargers shall ensure that diked areas are sufficiently impervious to contain discharged chemicals.
- d. Discharger(s) shall implement spill prevention, control, and countermeasures (SPCC) and have appropriate cleanup materials available onsite.
- e. Underground storage tanks 110 gallons and larger shall be registered with the appropriate County Health Department and comply with State and local requirements for leak detection, spill overflow, corrosion protection, and insurance coverage.

Electricity on most of the property is provided by a large diesel generator and, at times by solar panels on the property. A diesel generator is housed within a fully enclosed, permanent generator shed on the property. It is shown as shed "G" on the WRPP Map. The shed is equipped with a cement floor and a large secondary containment tank for the contents of fuel inside of the generator. The diesel fuel storage for the generator is in a large metal fuel tank, equipped with secondary containment, and housed within a permanent shed dedicated to fuel storage. It is shown as shed "F" on the WRPP Map. Outside, off of the side of the fuel storage shed, is two gasoline storage tanks. One was equipped with permanent secondary containment. The other was smaller and was not equipped with secondary containment. Both of these tanks were located outside, unprotected from precipitation. In order to be in compliance with Standard Condition A. 9 above, the fuel tanks shall be equipped with secondary containment, and a cover and side-wind protection throughout the rainy season. This could include tarping or enclosing within a temporary or permanent shed during rain storms.

10. Cultivation-related wastes: **In compliance?** Y /N (see below)

Cultivation-related wastes including, but not limited to, empty soil/soil amendment/ fertilizer/pesticide bags and containers, empty plant pots or containers, dead or harvested plant waste, and spent growth medium shall, for as long as they remain on the site, be stored⁸ at locations where they will not enter or be blown into surface waters, and in a manner that ensures that residues and pollutants within those materials do not migrate or leach into surface water or groundwaters.

⁸Plant waste may also be composted, subject to the same restrictions cited above for cultivation-related waste storage.

The cultivation spoils pile that is located near the northeast corner of the property is not currently in compliance with this Standard Condition or Standard Conditions A(4) and A(7) as discussed previously in this report. It contains spent growth medium. As stated above, this pile needs to be tarped and surrounded by straw wattles or removed to a more stable location.

With the exception of this one location, the rest of the property is in compliance with this Standard Condition. Storing of cultivation wastes was not taking place on the property during the assessment. Cultivation wastes are periodically taken to the nearest waste disposal location. Dead and harvested plant waste is composted or sometimes burned near the cultivation areas, far from any watercourses. In order to remain in compliance with Standard Condition 10 above, all cultivation-related waste in the form of empty bags, containers, pots and, dead or harvested plant waste and spent growth medium shall be stored where they will not enter or be blown into surface

waters, or removed from the site and disposed of properly. Cultivation-related wastes that contain residues or pollutants shall be stored in a manner that ensures that those materials do not leach into surface water or groundwaters. This can be achieved by following Items 137 and 139 in Appendix B of the Order.

11. Refuse and human waste: In compliance? Y /N

- a. Disposal of domestic sewage shall meet applicable County health standards, local agency management plans and ordinances, and/or the Regional Water Board's Onsite Wastewater Treatment System (OWTS) policy, and shall not represent a threat to surface water or groundwater.
- b. Refuse and garbage shall be stored in a location and manner that prevents its discharge to receiving waters and prevents any leachate or contact water from entering or percolating to receiving waters.
- c. Garbage and refuse shall be disposed of at an appropriate waste disposal location.

Sewage disposal on the property are two functioning septic systems on the property. One is connected to the house, the other is connected to the garage / shop. Waste water disposal on the property currently does not appear to be a threat to surface or ground water and was not causing a nuisance on the property. The Discharger stated that both septic systems on the property were permitted by Humboldt County. In order to be in full compliance with Standard Condition 11.a., the septic systems need to meet applicable County health standards, local agency management plans and ordinances, and/or the Regional Water Board's Onsite Wastewater Treatment System (OWTS) policy. See Appendix B. Item 142 of the Order.

Household garbage and refuse was not accumulated or being stored on the property on the inspection date. According to the discharger, garbage is stored in sealed bags or garbage cans with lids and periodically taken to the dump. Garbage is stored near the garage far from any watercourses. In order to be in compliance with Standard Condition 11. b. and c. above, refuse and garbage shall be stored in a location and manner that prevents its discharge to receiving waters and prevents any leachate or contact water from entering or percolating to receiving waters. This can be accomplished by storing garbage in covered containers or keeping it tarped during the winter. Garbage and refuse shall be disposed of at an appropriate waste disposal location. See Appendix B. Item 141 of the Order.

12. Remediation/Cleanup/Restoration Remediation/cleanup/restoration activities may include, but are not limited to, removal of fill from watercourses, stream restoration, riparian vegetation planting and maintenance, soil stabilization, erosion control, upgrading stream crossings, road outcropping and rolling dip installation where safe and suitable, installing ditch relief culverts and overside drains, removing berms, stabilizing unstable areas, reshaping cutbanks, and rocking native-surfaced roads. Restoration and cleanup conditions and provisions generally apply to Tier 3 sites, however owners/operators of Tier 1 or 2 sites may identify or propose water resource improvement or enhancement projects such as stream restoration or riparian planting with native vegetation and, for such projects, these conditions apply similarly. Appendix B accompanying this Order includes environmental protection and mitigation measures that apply to cleanup activities such as: temporal limitations on construction; limitations on earthmoving and construction equipment; guidelines for removal of plants and revegetation; conditions for erosion control, limitations on work in streams, riparian and wetland areas; and other measures.

Mitigation measures are listed in the Water Resource Protection Plan and also noted above in this document.

Pictures

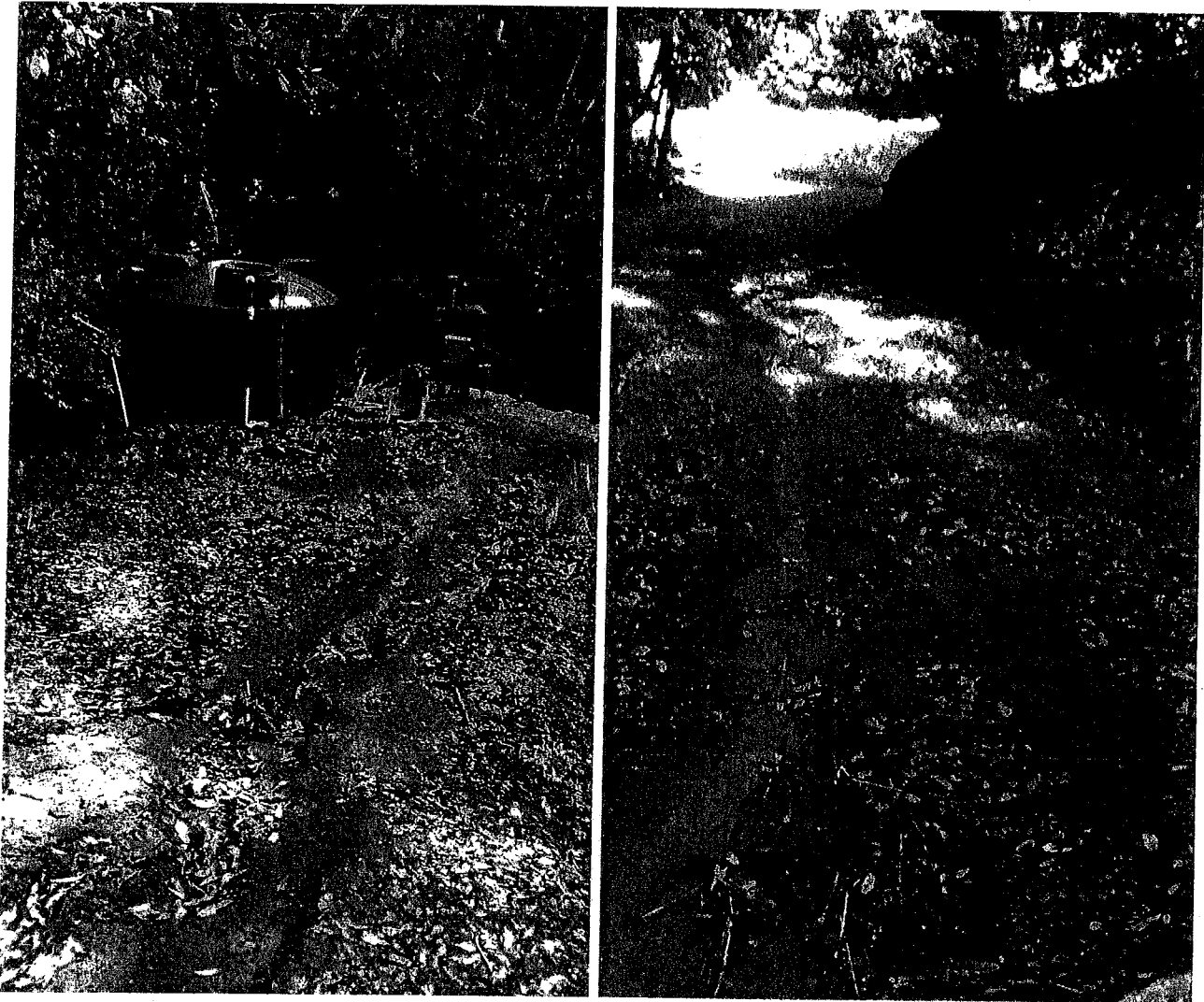

Pictures 1 and 2: These are the pictures taken along the segment of Map Point 2 prior to the recent rock lining of the inside ditch. The picture on the left shows the south end of the road segment identified as Map Point 2 on the WRPP Map. The picture on the right is taken from south end of this road segment and is looking up the road in a northerly direction. The recent October rainfall has caused the runoff to overflow the inside ditch and over the fill at the end of the road. The most feasible mitigation for this connected road segment is to deepen and rock line the existing inside ditch from the north end of the segment, to the Class III watercourse at the south end of the segment. The Discharger had recently installed erosion control "Jute" Netting on the face of the road fill. Photo date 11/3/2016

Pictures



Picture 3: This is a picture of the newly rock lined drainage channels located upslope of Map Point 2. The channel on the left extends from the outlet of an existing ditch relief culvert. The channel on the right extends from the surface of the developed cultivation area. Photo date 12/2/2016

Pictures



Pictures 4 and 5: These pictures show the bottom of the newly rock lined drainage channels and where they intersect with the newly rock lined inside ditch along Map Point 2. Photo date 12/2/2016

Pictures



Picture 6: This is a picture along Map Point 2 showing the bottom half of the newly rock lined inside ditch taken from near the location of picture 2 above. Photo date 12/2/2016

Pictures



Picture 7: This is a picture at the end of the road where the rock lining of the ditch ends at the south end of Map Point 2. Photo date 12/2/2016

Pictures



Pictures 8 and 9: The picture on the left shows recently widened and rock lined ditch. In it, the rock lined ditch shall be extended over the end of the road, towards the Class III watercourse. A rolling dip shall be installed just prior to the end of the road, to drain the road surface towards the right so that it no longer can drain over the fill slope straight off of the end of the road. The picture on the right shows the grassed over jute netting placed on the fills beyond the end of the road. Rock armor shall be placed along the bottom edge of the jute netting and in the small erosion gully in the foreground of the photo. Photo date 2/13/2017

Pictures



Picture 10: This is a picture of the newly rock lined drainage ditch that drains a "French drain" outlet that collects from the surface of the developed cultivation area. It ends above a swale that contains the top of a Class III watercourse. Photo date 12/2/2016

Pictures



Picture 11: This is a picture of the outlet of the existing ditch relief culvert near in the southeastern corner of the property. The small drainage pictured below this culvert extends and meanders for approximately 300 feet to the small Class III watercourse below. Installation of a 15 inch diameter, ditch relief culvert approximately 120 feet northeast of this location, at Map Point 3, is expected to reduce the volume of water draining from this culvert so that runoff is dispersed prior to it reaching a watercourse. Photo date 11/3/2016

Pictures

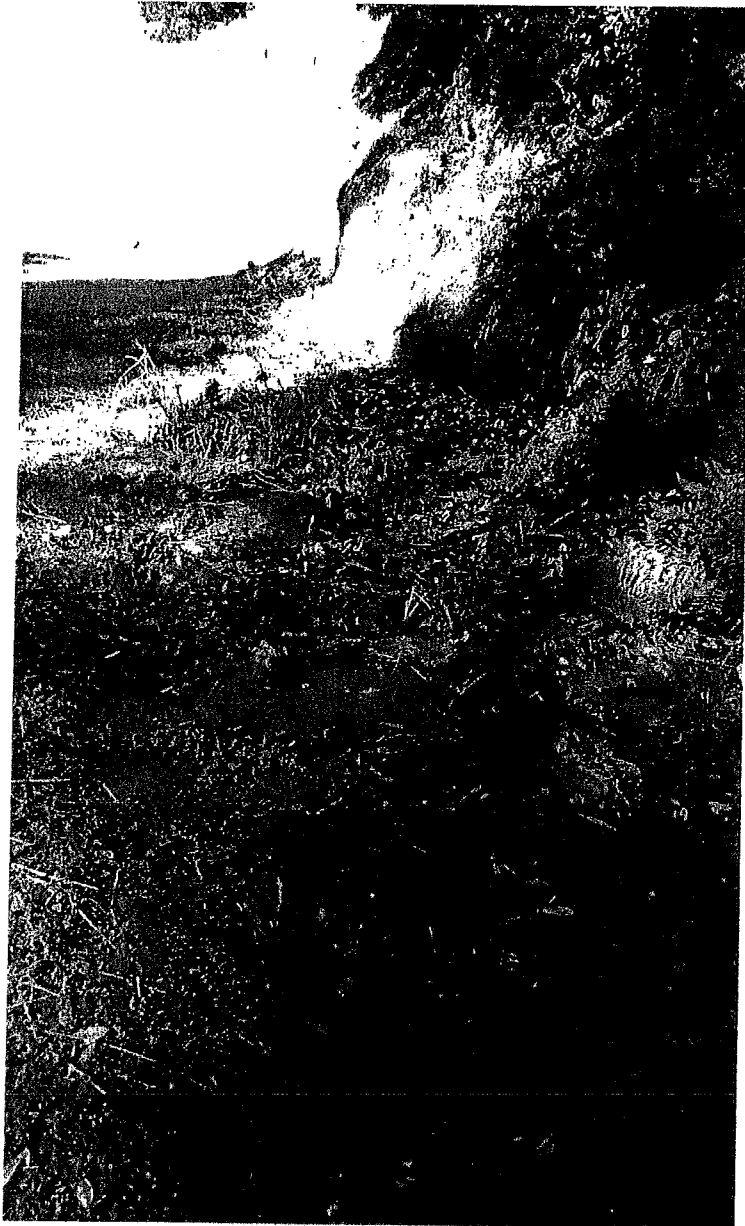

Picture 12: This is a picture of some of the leftover rock armoring along the connected inside ditch drainage that is shown as Map Point 6. The most feasible mitigation for this connected inside ditch segment is to deepen and rock line the existing inside ditch from the west end of the segment, to the Class III watercourse at the southeast end of the segment. Photo date 11/3/2016

Pictures



Pictures 13 and 14: These are pictures taken at the southeast of Map Point 6. It shows the eroded gully between the end of the road and the Class III watercourse. The dog in the picture on the right is pointing up the natural Class III watercourse. Photo date 12/2/2016

Pictures

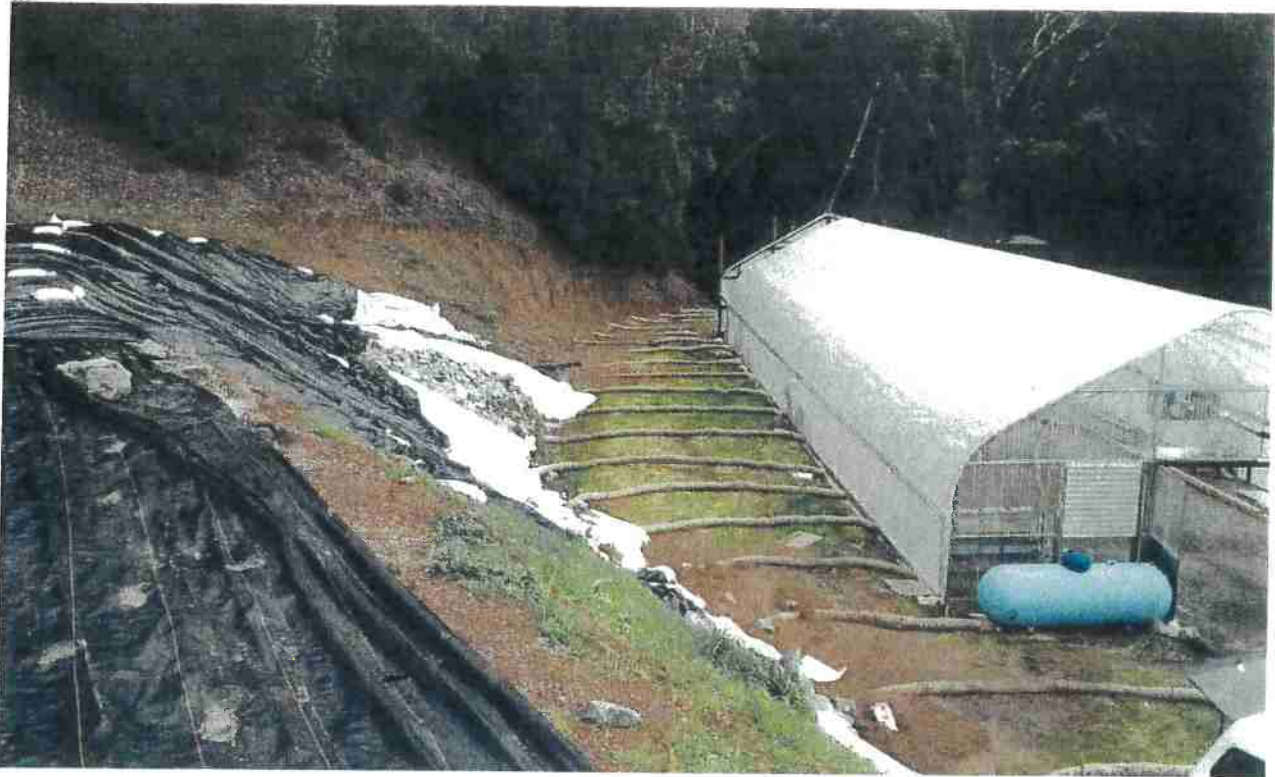

Picture 15: This is a picture of the area of Map Point 6 on the WRPP Map. The straw wattles were recently installed to trap sediment from reaching the watercourse beyond the end of the greenhouse in the picture. The terraced area in the left half of the picture is slumping slightly and will be re-configured as stated in the report. Photo date 2/13/2017

Pictures



Pictures 16 and 17: The picture on the left shows the heavily rock armored inlet above the inlet at Map Point 7. The inlet is located at the lower left corner of the picture. The picture on the right shows the outlet of the culvert at Map Point 7 taken from the surface of the roads. Photo date 11/3/2016

Pictures

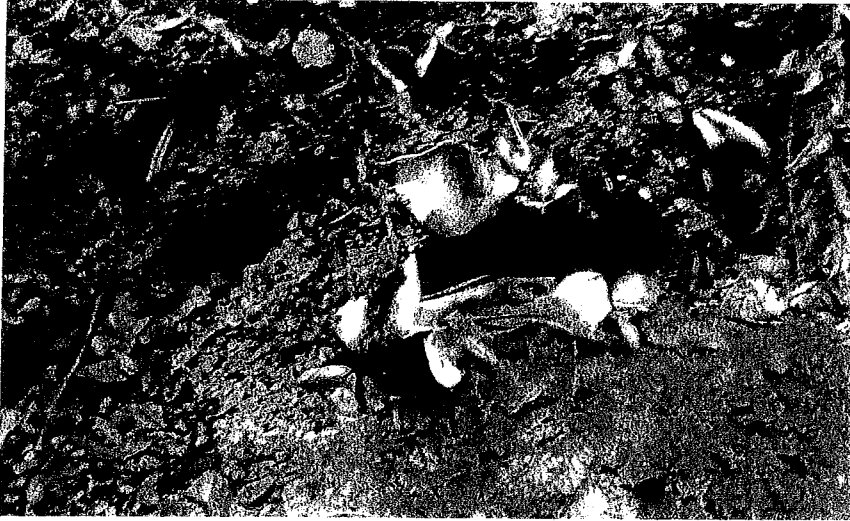

Pictures 18 and 19: These are pictures of the crushed inlet and outlet of the existing culvert draining the bank seep / spring at Map Point 8 on the WRPP Map. Photo date 12/2/2016

Pictures



Picture 20: This picture shows the cultivation spoils pile that is located in the northeast corner of the property. To be in compliance it should be covered and contained with straw wattles or removed. Photo date 11/3/2016

Pictures

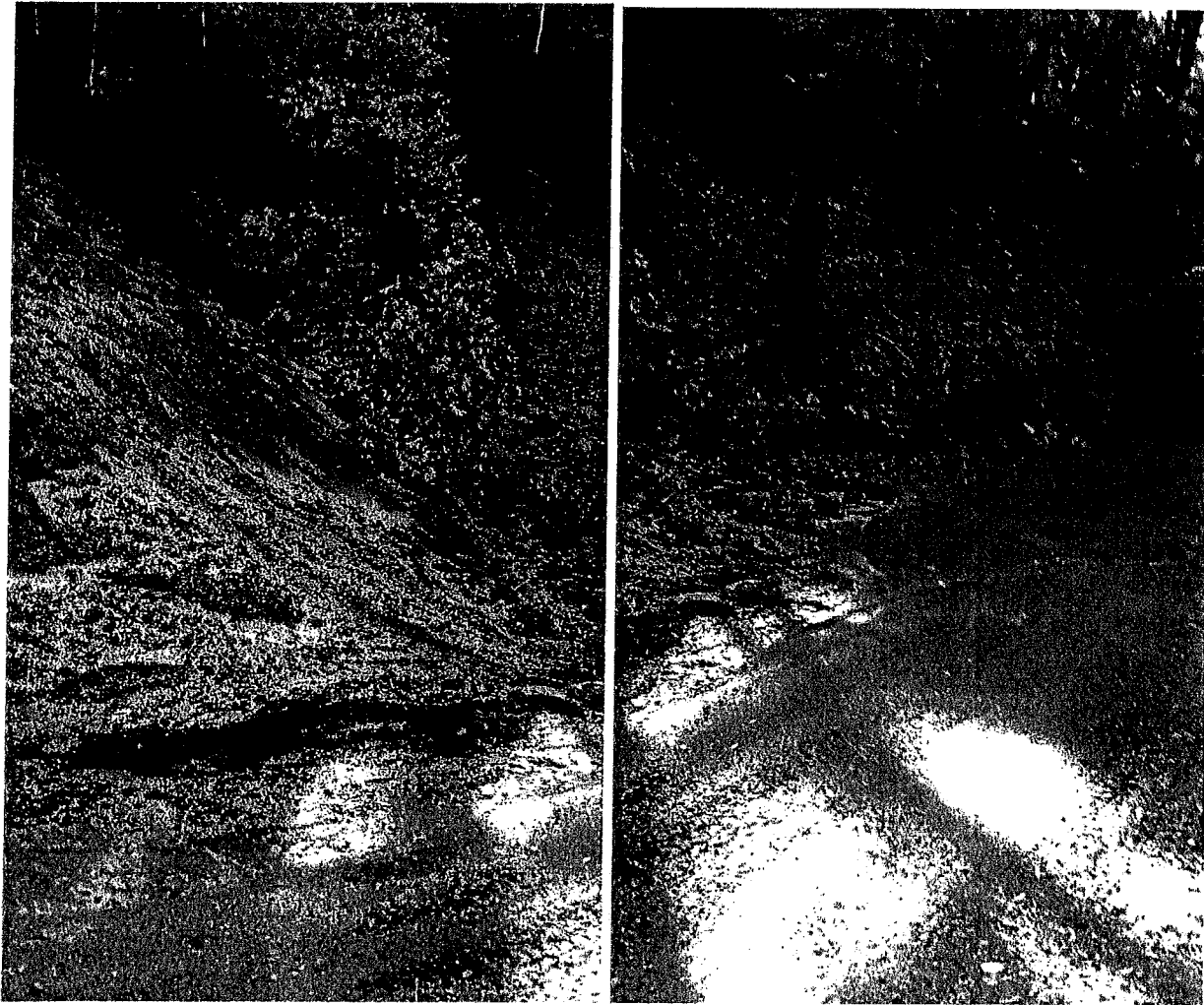

Pictures 21 and 22: This picture shows the base of the spoils pile and the shallow road drainage feature that conveys road runoff across the road. To be in compliance, the pile should be covered and contained with straw wattles or removed. Photo date 11/3/2016

Pictures



Picture 23: The large building in this picture is the garage / shop and the smaller building is the fuel storage shed. Off of the right side of the fuel storage shed are two gasoline storage tanks. The white square tank on the wooden platform needs secondary containment and both tanks need to be tarped or covered from precipitation during the winter to prevent secondary containment tanks from filling with rain. Photo date 11/3/2016

BMP: Ditch Relief Culvert

- Install ditch relief culverts at an oblique (typically 30 degree) angle to the road so that ditch flow is not forced to make a sharp angle turn to enter the pipe. On low gradient roads (<5%), where ditch flow is slow, ditch relief culverts can be installed at right angles to the road.
- Install ditch relief culverts (DRC) to outlet at, and drain to, the base of the fill.
- If it cannot be installed at the base of the fill, install the DRC with a grade steeper than the inboard ditch draining to the culvert inlet, and install a downspout on the outlet to carry the culverted flow to the base of the fillslope.
- Downspouts longer than 20 feet should be secured to the hillslope for stability.
- Ditch relief culverts should not carry excessive flow such that downcutting of the ditchline or gullying below the outlet occur.
- Do not discharge flows from ditch relief culverts onto unstable fill or active landslides.
- If the ditch is on an insloped or crowned road, consider using outsloping to drain the road surface. The ditch and the ditch relief culvert would then convey only spring flow from the cutbanks and hillslope runoff, and not turbid runoff from the road surface.

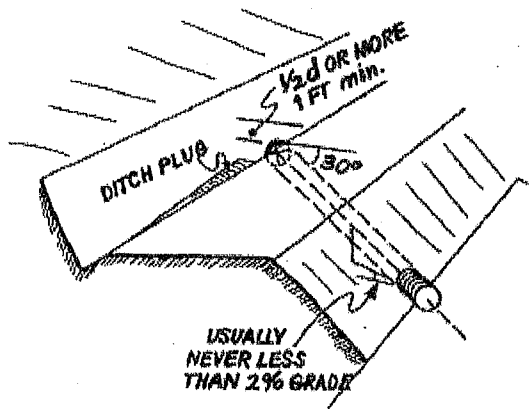
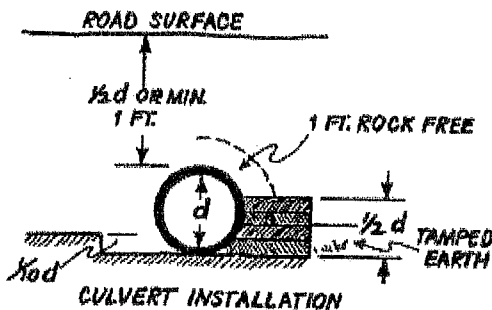

FIGURE 48. The elements of a properly installed ditch relief culvert. The culvert is angled at about 30 degrees to the road alignment to help capture flow and prevent culvert plugging or erosion of the inlet area. It is set at the base of the fill (ideally) or with a grade slightly steeper than the grade of the contributing ditch (but never with a grade less than 2 percent) (USDA-SCS, 1983). At a minimum, the grade of the ditch relief culvert should be sufficient to prevent sediment accumulation at the inlet or deposition within the culvert itself (it should be self-cleaning) (USDA-SCS, 1983).



HANDBOOK FOR FOREST, RANCH AND RURAL ROADS

BMP: Rolling Dip

- Rolling dips are drainage structures designed to capture and discharge surface water collected on road surfaces and in inside ditches at a specific location.
- The road shall dip into and out of the rolling dip to eliminate the possibility of water flowing along the road surface or in an inside ditch to bypass the dip structure.
- The rolling dip shall be constructed with clean native materials.
- The rolling dips outlet may be armored to resist downcutting and erosion.
- Do not discharge rolling dips into swales that show signs of instability or active landsliding.
- If the rolling dip is designed to divert both road surface and ditch runoff, block the down-road ditch with compacted fill.

BMP: Rocked Rolling Dip

- Rocked Rolling dips are drainage structures designed to capture and discharge surface water collected on road surfaces and in inside ditches at a specific location.
- The road shall dip into and out of the rolling dip to eliminate the possibility of water flowing along the road surface or in an inside ditch to bypass the dip structure.
- The rocked rolling dips inlet and outlet shall be armored to resist downcutting and erosion.
- The entire length of the rocked rolling dip shall be rock armored to a minimum of 5-feet from the centerline of the dip.
- If a keyway is necessary, the rocked rolling dip keyway shall be constructed at the base of the dip and shall be of sufficient size, depth, and length to support materials used in the rocked rolling dip construction back up to the road crossing interface.
- Do not discharge rolling dips into swales that show signs of instability or active landsliding.
- If the rolling dip is designed to divert both road surface and ditch runoff, block the down-road ditch with compacted fill.
- The rolling dip must be drivable and not significantly inhibit traffic and road use.

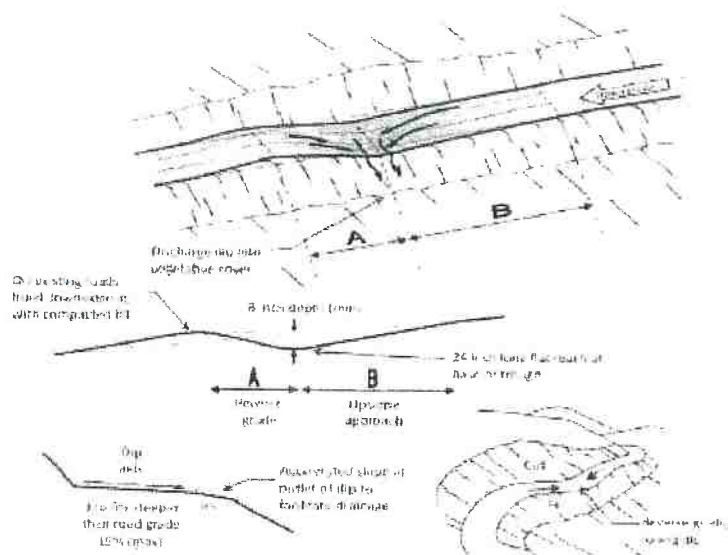

FIGURE 34 A classic Type 1 rolling dip, where the excavated up-road approach (B) to the rolling dip is several percent steeper than the approaching road and extends for 60 to 80 feet to the dip axis. The lower side of the structure reverses grade (A) over approximately 15 feet or more, and then falls down to rejoin the original road grade. The dip must be deep enough that it is not obliterated by normal grading, but not so deep that it is difficult to negotiate or a hazard to normal traffic. The outward cross-slope of the dip axis should be 3% to 5% greater than the up-road grade (B) so it will drain properly. The dip axis should be out-sloped sufficiently to be self-cleaning, without triggering excessive downcutting or sediment deposition in the dip axis (Modified from Best, 2013).

—HANDECOX FOR FOREST RANCH AND RURAL ROADS

Water Resource Protection Plan

General Location Map - WDID1B16459CHUM

NORTH

Map Scale 1 inch = 2,000 feet
Section 21, T4S, R2E, HB&M
Briceland USGS 7.5' Quad. C.1 = 40 feet

 Property Boundary

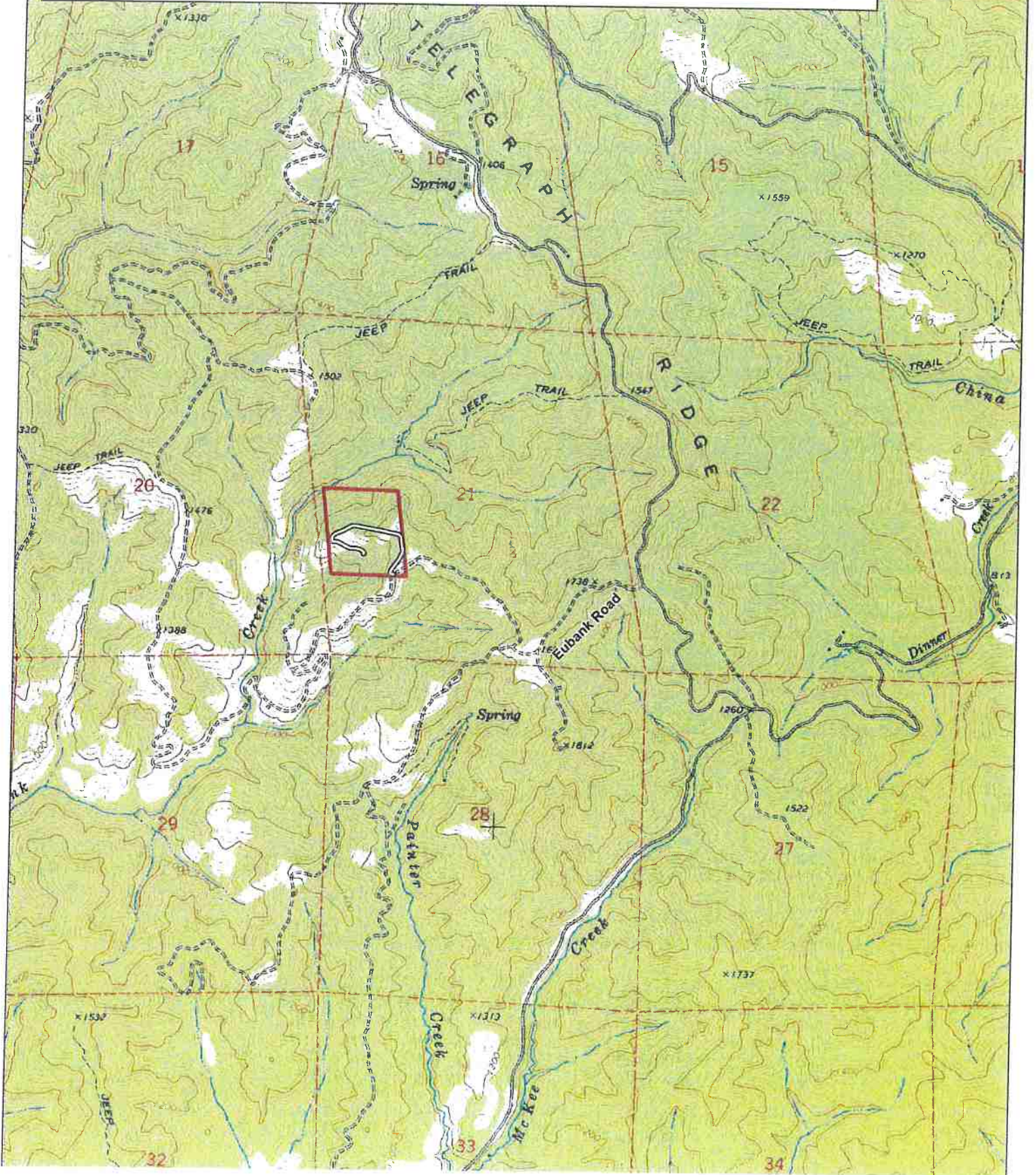

Water Resource Protection Plan

WRPP Map - WDID1B16459CHUM

NORTH

Map Scale 1 inch = 200 feet
 APN 220-081-016 - Section 21, T4S, R2E, HB&M
 Briceland USGS 7.5' Quad. C. 1. = 40 feet

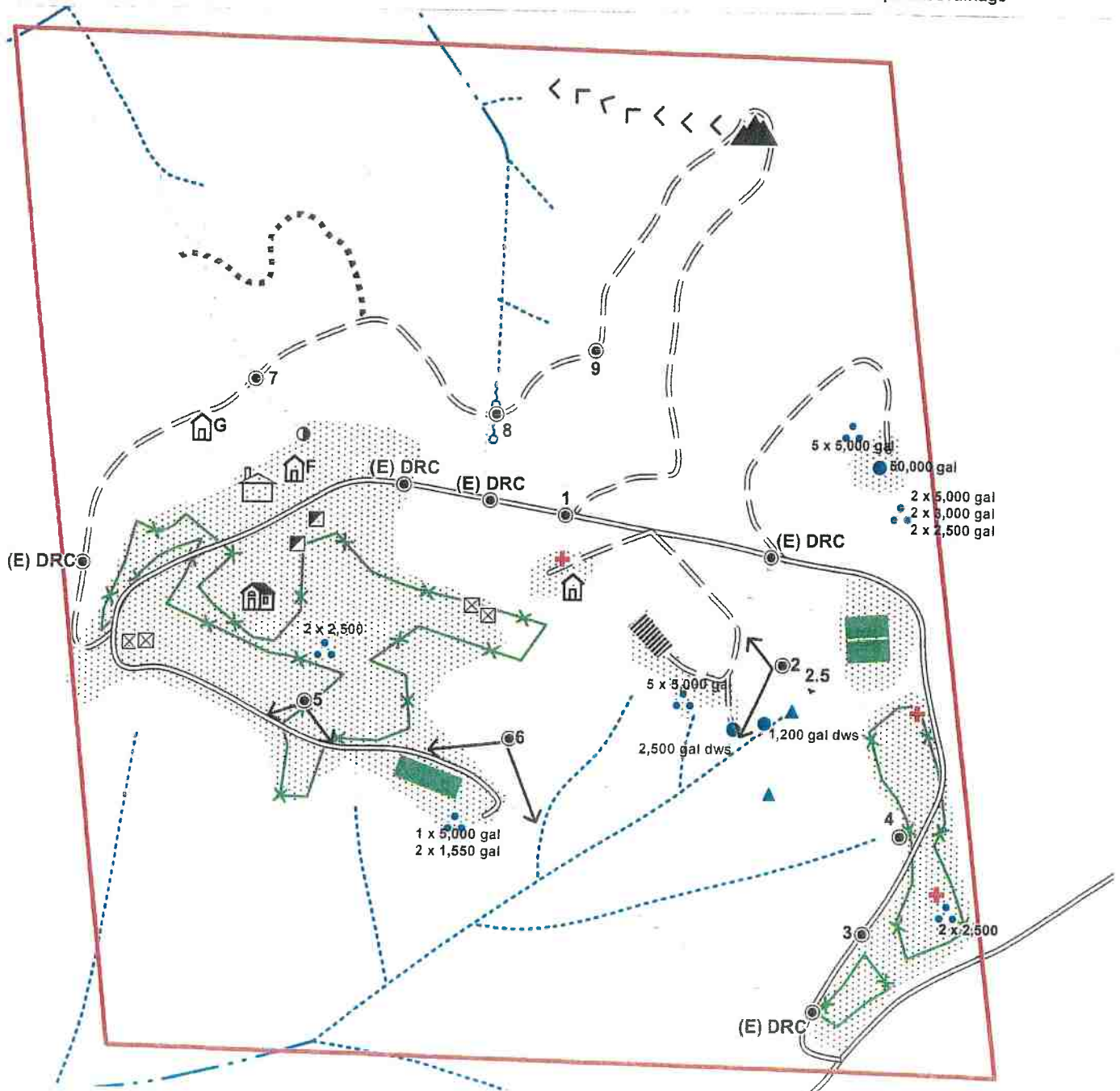
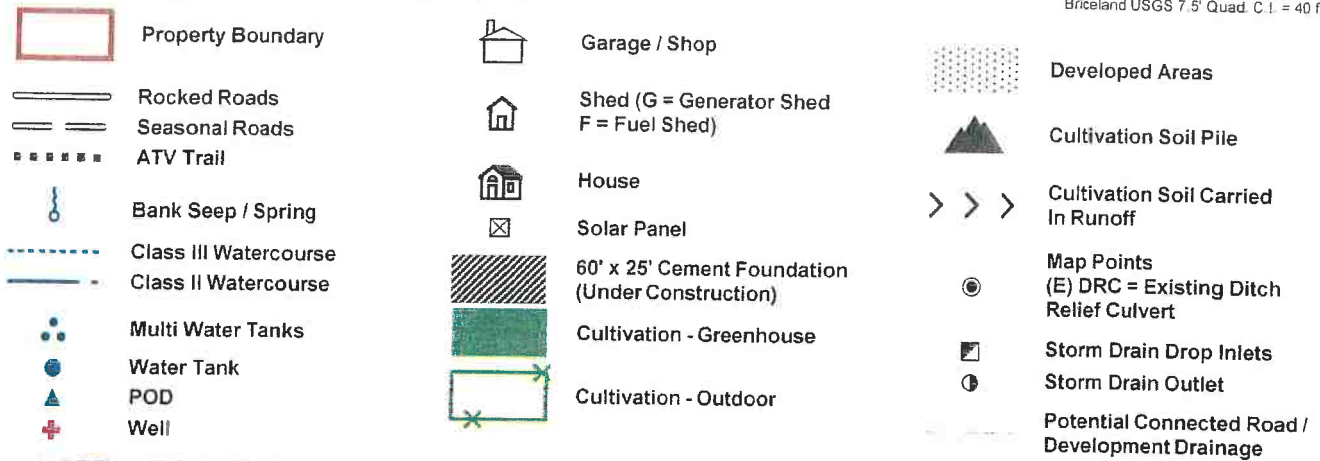

























Water Resource Protection Plan

WRPP Map - WDID1B16459CHUM

NORTH

Map Scale 1 inch = 200 feet
 APN 220-081-016 - Section 21, T4S, R2E, HB&M
 Briceland USGS 7.5' Quad. C.I. = 40 feet

- | | | | | | |
|---|-----------------------|---|---|---|--|
|  | Property Boundary |  | Garage / Shop |  | Developed Areas |
|  | Rocked Roads |  | Shed (G = Generator Shed
F = Fuel Shed) |  | Cultivation Soil Pile |
|  | Seasonal Roads |  | House |  | Cultivation Soil Carried
In Runoff |
|  | ATV Trail |  | Solar Panel |  | Map Points
(E) DRC = Existing Ditch
Relief Culvert |
|  | Bank Seep / Spring |  | 60' x 25' Cement Foundation
(Under Construction) |  | Storm Drain Drop Inlets |
|  | Class III Watercourse |  | Cultivation - Greenhouse |  | Storm Drain Outlet |
|  | Class II Watercourse |  | Cultivation - Outdoor |  | Potential Connected Road /
Development Drainage |
|  | Multi Water Tanks | | | | |
|  | Water Tank | | | | |
|  | POD | | | | |
|  | Well | | | | |

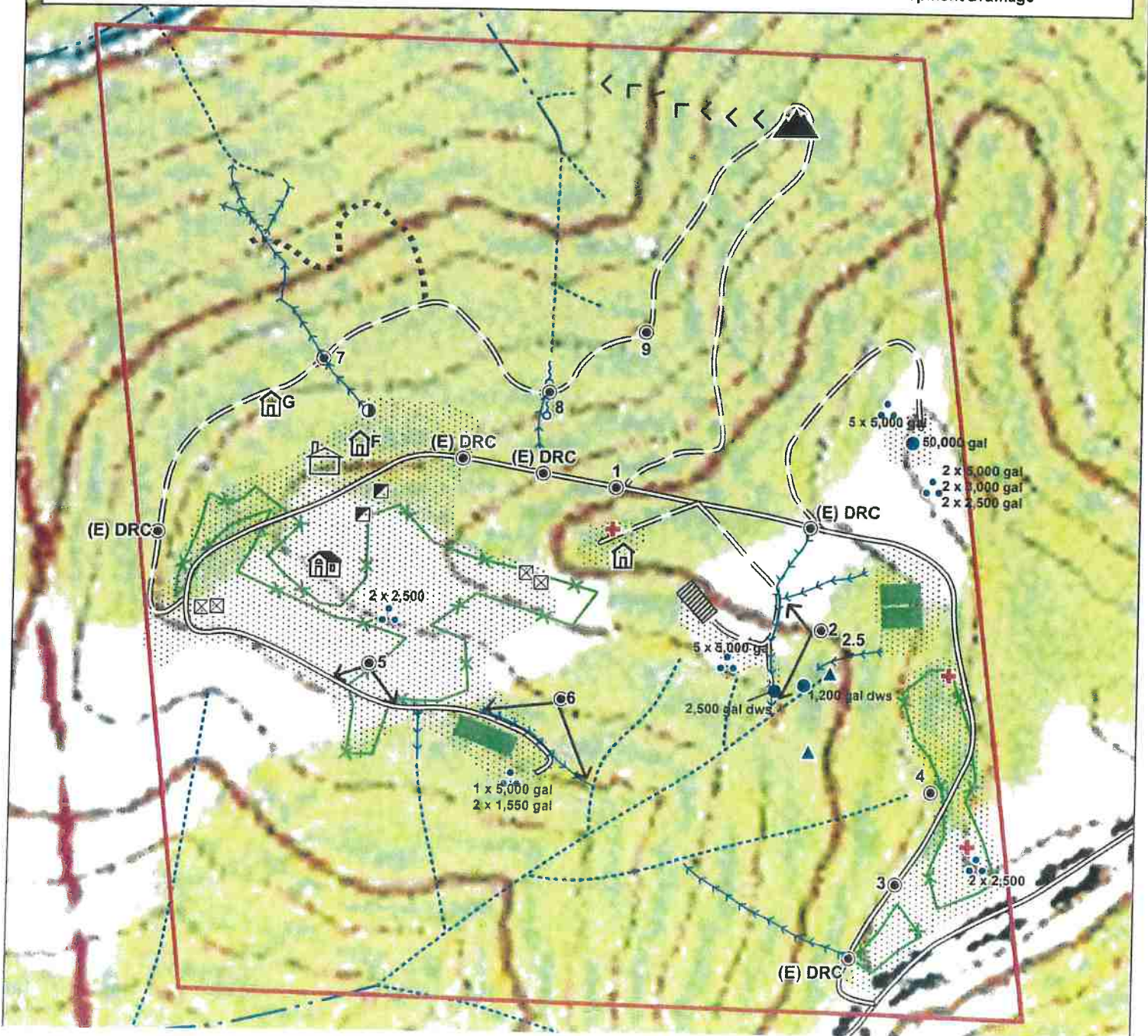

























Water Resource Protection Plan

WRPP Map - WDID1B16459CHUM

NORTH

Map Scale 1 inch = 200 feet
 APN 220-081-016 - Section 21, T4S, R2E, HB&M
 Briceland USGS 7.5' Quad. C.I. = 40 feet

- | | | | | | |
|---|-----------------------|---|---|---|--|
|  | Property Boundary |  | Garage / Shop |  | Developed Areas |
|  | Rocked Roads |  | Shed (G = Generator Shed
F = Fuel Shed) |  | Cultivation Soil Pile |
|  | Seasonal Roads |  | House |  | Cultivation Soil Carried
In Runoff |
|  | ATV Trail |  | Solar Panel |  | Map Points
(E) DRC = Existing Ditch
Relief Culvert |
|  | Bank Seep / Spring |  | 60' x 25' Cement Foundation
(Under Construction) |  | Storm Drain Drop Inlets |
|  | Class III Watercourse |  | Cultivation - Greenhouse |  | Storm Drain Outlet |
|  | Class II Watercourse |  | Cultivation - Outdoor |  | Potential Connected Road /
Development Drainage |
|  | Multi Water Tanks | | | | |
|  | Water Tank | | | | |
|  | POD | | | | |
|  | Well | | | | |

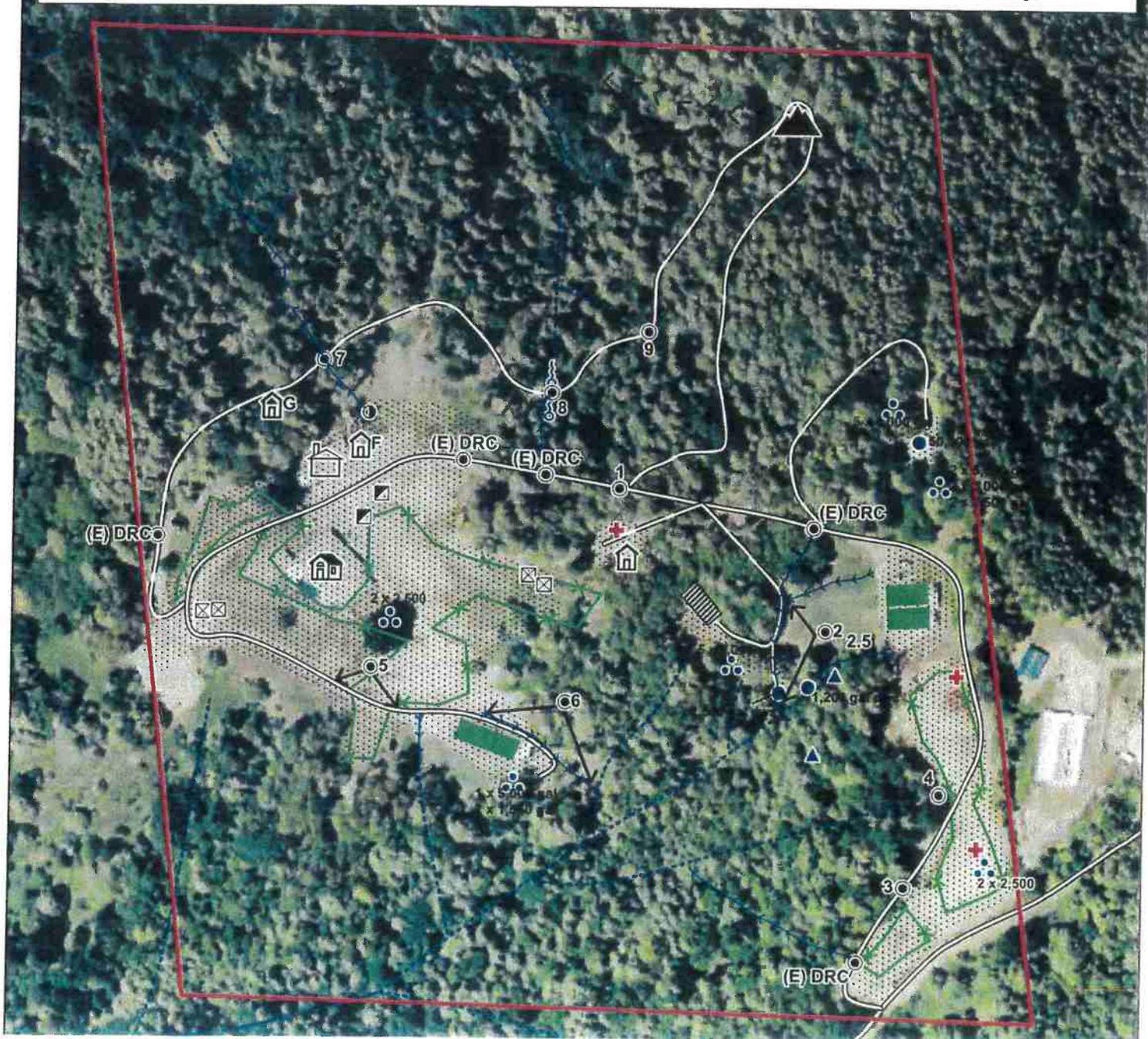



Humboldt County Department of Health and Human Services
DIVISION OF ENVIRONMENTAL HEALTH

100 H Street - Suite 100 - Eureka, CA 95501
 Voice: 707-445-6215 - Fax: 707-441-5699 - Toll Free: 800-963-9241
 envhealth@co.humboldt.ca.us

RECEIVED
 SEP 24 2009
 09110-0164
 HUMBOLDT CO. DIVISION
 OF ENVIRONMENTAL HEALTH

WATER WELL APPLICATION
CONSTRUCTION - REPAIR - DESTRUCTION

Instructions:

1. Complete both pages of the application and submit the required fee with the Well Permit application, including Well Driller's signature.
2. The Well Permit will be returned to the property owner by mail when approved by the Humboldt County Division of Environmental Health (DEH).
3. Work on the well shall not be started prior to approval of the Well Permit Application by DEH.
4. Any changes made to the location of a new well shall be approved by DEH prior to commencement of drilling.
5. DEH shall be notified by the Well Driller a minimum of 24 hours prior to sealing the annular space.

Site Address 569 EUBANKS ROAD APN 220-081-016

City/State/Zip WHITETHORN CA 95589

Directions to Site _____

Property Owner THOMAS HARWOOD

Mailing Address P.O. BOX 264

City/State/Zip REDWAY CA 95560 Phone 707-834-4738

I hereby grant right-of-entry for inspection purposes

Drilling Contractor FISCH DRILLING License # 683865

I hereby agree to comply with all laws and regulations of the County of Humboldt and the State of California Department of Water Resources Bulletin 74 pertaining to water well construction. I will contact Humboldt County Division of Environmental Health (DEH) when I commence work. Within 15 days after completion of work, I will furnish DEH a report of the work performed and notify them before putting the well into use.

Well Driller Signature: [Signature]

Type of Application:
 Construction \$329.00
 Repair \$116.00
 Destruction \$116.00

Estimated Work Dates:
OCT 2009 Start
 _____ Completion

Construction:
 Estimated Depth (ft.) _____
 Diameter (in.) 10
 Depth of Seal (ft.) 20
 Sealing Material Bentonite

Casing:
 Diameter (in.) 5
 Material: CL200 PVC

Intended Use:
 Domestic - private
 Community Supply
 Irrigation
 Other _____

Type of Sewage System:
 Community Sewer
 Septic System
 Distance from well site to septic system(s) 1000'

FOR OFFICE USE ONLY

Fee: \$329.00
 Date: 9-24-09
 Receipt: 0014514
 By: [Signature]
 Approved by: _____

Permit Number _____

Site Approved By: [Signature] 10/30/09
 Site Finaled By: _____
 Sealed to Depth of: _____
 Seal Observed: Yes No
 Date Approved: _____

TRIF-LICATE
Owner's Copy

STATE OF CALIFORNIA
WELL COMPLETION REPORT

Refer to Instruction Pamphlet

No. **1087868**

DWR USE ONLY — DO NOT FILL IN

STATE WELL NO./STATION NO.

LATITUDE LONGITUDE

APN/TRS/OTHER

Page ___ of ___

Owner's Well No. 1

Date Work Began 2/15/2011, Ended 2/17/2011

Local Permit Agency San Bernardino

Permit No. W-17-10285 Permit Date 2/17/2011

GEOLOGIC LOG

WELL OWNER

ORIENTATION (✓) VERTICAL HORIZONTAL ANGLE _____ (SPECIFY)

DRILLING METHOD Hand FLUID _____

Name Tom Hamilton

Mailing Address 2400 26th

CITY Redlands STATE CA ZIP 92370

DEPTH FROM SURFACE

Ft.	to	Ft.	DESCRIPTION
-----	----	-----	-------------

WELL LOCATION

Address 2400 26th

City Redlands

County San Bernardino

0	29	Soft brown sand
29	30	Grey shale
30	30	Hard grey shale
30	35	Shale with thin layers of water
35	140	Hard sandstone

APN Book _____ Page _____ Parcel 236-011-116

Township _____ Range _____ Section _____

Lat _____ Long _____

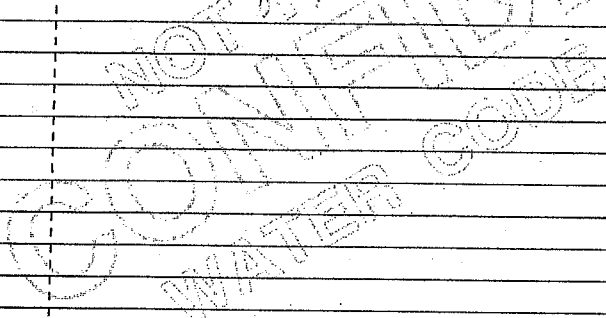

APN Book _____ Page _____ Parcel 236-011-116

Township _____ Range _____ Section _____

Lat _____ Long _____

LOCATION SKETCH

ACTIVITY (✓)

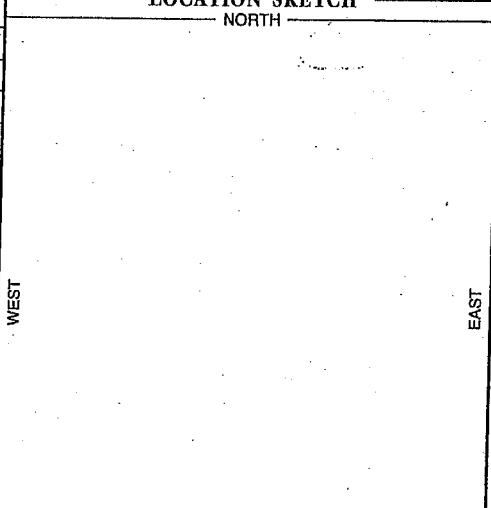

- NEW WELL
- MODIFICATION/REPAIR
 - Deepen
 - Other (Specify) _____
- DESTROY (Describe Procedures and Materials Under "GEOLOGIC LOG")
- USES (✓)**
- WATER SUPPLY
 - Domestic Public
 - Irrigation Industrial
- MONITORING
- TEST WELL
- CATHODIC PROTECTION
- HEAT EXCHANGE
- DIRECT PUSH
- INJECTION
- VAPOR EXTRACTION
- SPARGING
- REMEDICATION
- OTHER (SPECIFY) _____

Illustrate or Describe Distance of Well from Roads, Buildings, Fences, Rivers, etc. and attach a map. Use additional paper if necessary. **PLEASE BE ACCURATE & COMPLETE.**

WATER LEVEL & YIELD OF COMPLETED WELL

DEPTH TO FIRST WATER 110 (Ft.) BELOW SURFACE

DEPTH OF STATIC WATER LEVEL _____ (Ft.) & DATE MEASURED 2/17/2011

ESTIMATED YIELD * 100 (GPM) & TEST TYPE Static

TEST LENGTH _____ (Hrs.) TOTAL DRAWDOWN _____ (Ft.)

* May not be representative of a well's long-term yield.

TOTAL DEPTH OF BORING 140 (Feet)

TOTAL DEPTH OF COMPLETED WELL 140 (Feet)

DEPTH FROM SURFACE Fl. to Ft.	BORE-HOLE DIA. (Inches)	CASING (S)					MATERIAL / GRADE	INTERNAL DIAMETER (Inches)	GAUGE OR WALL THICKNESS	SLOT SIZE IF ANY (Inches)	DEPTH FROM SURFACE Fl. to Ft.	ANNULAR MATERIAL			
		TYPE (✓)										CE- MENT (✓)	BEN- TONITE (✓)	FILL (✓)	FILTER PACK (TYPE/SIZE)
0 to 30	9"	✓					F 470	5"	9/16"	0 to 27					
30 to 140	1"	✓					11	11	1/2"	27 to 140				200 mesh	

ATTACHMENTS (✓)

- Geologic Log
- Well Construction Diagram
- Geophysical Log(s)
- Soil/Water Chemical Analyses
- Other _____

ATTACH ADDITIONAL INFORMATION, IF IT EXISTS.

CERTIFICATION STATEMENT

I, the undersigned, certify that this report is complete and accurate to the best of my knowledge and belief.

NAME Bushnell Enterprises
(PERSON, FIRM, OR CORPORATION) (TYPED OR PRINTED)

ADDRESS 649 Bear Creek Rd CITY Corral STATE CA ZIP 95942

Signed [Signature] DATE SIGNED 2/17/2011
C-57 LICENSED WATER WELL CONTRACTOR C-57 LICENSE NUMBER _____

TRIPLICATE
Owner's Copy

STATE OF CALIFORNIA
WELL COMPLETION REPORT

Refer to Instruction Pamphlet

No. **1087869**

Page of

Owner's Well No.

Date Work Began 10-6-16 Ended 10-6-16

Local Permit Agency HUMB

Permit No. 16-17-0227 Permit Date 5-21-17

DWR USE ONLY — DO NOT FILL IN

STATE WELL NO./STATION NO.

LATITUDE LONGITUDE

APN/TRS/OTHER

GEOLOGIC LOG

WELL OWNER

ORIENTATION (∠) VERTICAL HORIZONTAL ANGLE (SPECIFY)

DRILLING METHOD ROTA-1 FLUID

Name TOMMY H. HARRISON

Mailing Address 1000 1/2

CITY BECKWYTH CA STATE CA ZIP 95570

DEPTH FROM SURFACE

Ft. to Ft.

WELL LOCATION

Address 569 WINDY

City BECKWYTH CA

County HUMBoldt

APN Book Page Parcel 020 261 016

Township Range Section

Lat Long

Describe material, grain size, color, etc.

DEPTH FROM SURFACE	DESCRIPTION
Ft. to Ft.	
0-10	Soft Dry Rock
10-65	Grey shale
65-130	Grey shale
130-160	Red Blue sand shale
160-200	Grey shale

LOCATION SKETCH

ACTIVITY (∠)

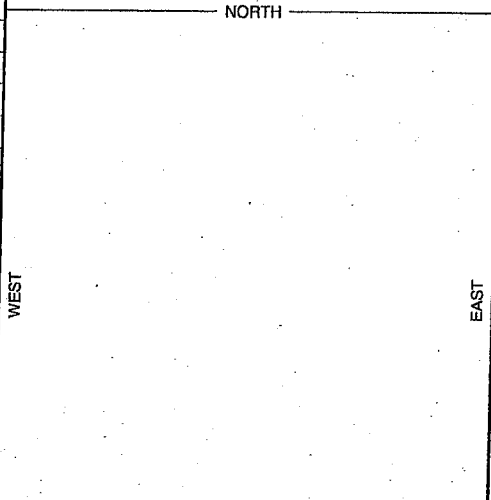

- NEW WELL
- MODIFICATION/REPAIR
- Deepen
 - Other (Specify)
- DESTROY (Describe Procedures and Materials Under "GEOLOGIC LOG")
- USES (∠)
- WATER SUPPLY
- Domestic Public
 - Irrigation Industrial
- MONITORING
- TEST WELL
- CATHODIC PROTECTION
- HEAT EXCHANGE
- DIRECT PUSH
- INJECTION
- VAPOR EXTRACTION
- SPARGING
- REMEDICATION
- OTHER (SPECIFY)

Illustrate or Describe Distance of Well from Roads, Buildings, Fences, Rivers, etc. and attach a map. Use additional paper if necessary. **PLEASE BE ACCURATE & COMPLETE.**

WATER LEVEL & YIELD OF COMPLETED WELL

DEPTH TO FIRST WATER 200 (Feet) BELOW SURFACE

DEPTH OF STATIC WATER LEVEL 190 (Feet) & DATE MEASURED 10-6-16

ESTIMATED YIELD * 15 (GPM) & TEST TYPE ABR 117

TEST LENGTH 1 (Hrs.) TOTAL DRAWDOWN (Feet)

* May not be representative of a well's long-term yield.

TOTAL DEPTH OF BORING 200 (Feet)

TOTAL DEPTH OF COMPLETED WELL 190 (Feet)

DEPTH FROM SURFACE	BORE-HOLE DIA. (Inches)	CASING (S)						DEPTH FROM SURFACE	ANNULAR MATERIAL				
		TYPE (∠)				MATERIAL / GRADE	INTERNAL DIAMETER (Inches)		GAUGE OR WALL THICKNESS	SLOT SIZE IF ANY (Inches)	TYPE		
Ft. to Ft.		BLANK	SCREEN	CON-DOCTOR	FILL PIPE								
0-160	7"					F4180	5"	3/4" x 1/8"					
160-200							6"		0.020				3/8" 100

ATTACHMENTS (∠)

CERTIFICATION STATEMENT

- Geologic Log
- Well Construction Diagram
- Geophysical Log(s)
- Soil/Water Chemical Analyses
- Other

I, the undersigned, certify that this report is complete and accurate to the best of my knowledge and belief.

NAME Rushell Enterprises
(PERSON, FIRM, OR CORPORATION) (TYPED OR PRINTED)





ADDRESS 1099 Beaconer Rd, Grap CA 95572 CITY STATE ZIP

Signed [Signature] DATE SIGNED 5-21-17 403700
C-57 LICENSED WATER WELL CONTRACTOR C-57 LICENSE NUMBER

ATTACH ADDITIONAL INFORMATION, IF IT EXISTS.

180101070202TRC71

WRPP Site Map

-  Property Line
-  Seasonal Road
-  Eubanks Creek (Class I)
-  Greenhouse

Preliminary Site Map

Map Date 06/16/2016

Map Scale 1" = 300'

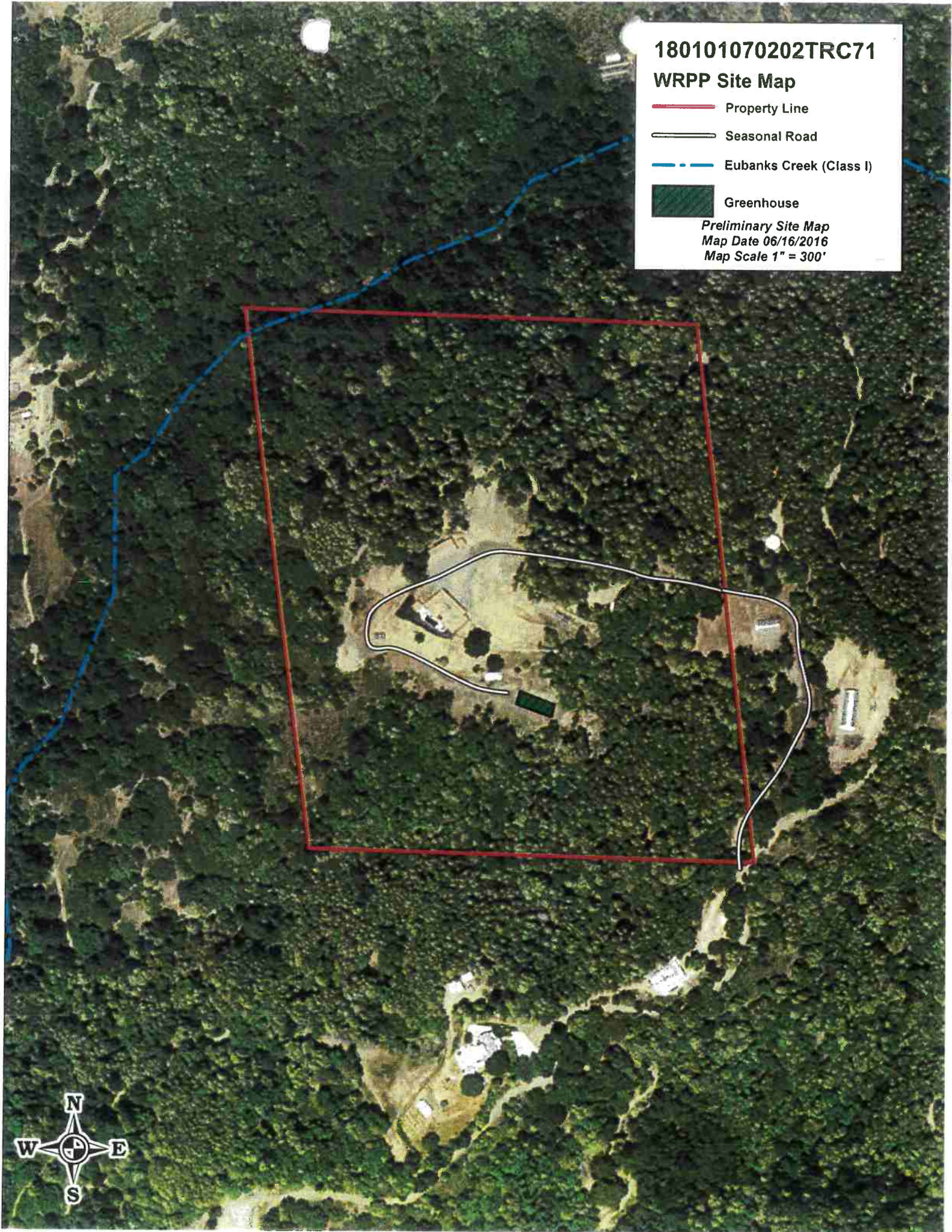

180101070202TRC71

WRPP Site Map

-  Property Line
-  Seasonal Road
-  Eubanks Creek (Class I)
-  Greenhouse

*Preliminary Site Map
Map Date 06/16/2016
Map Scale 1" = 300'*

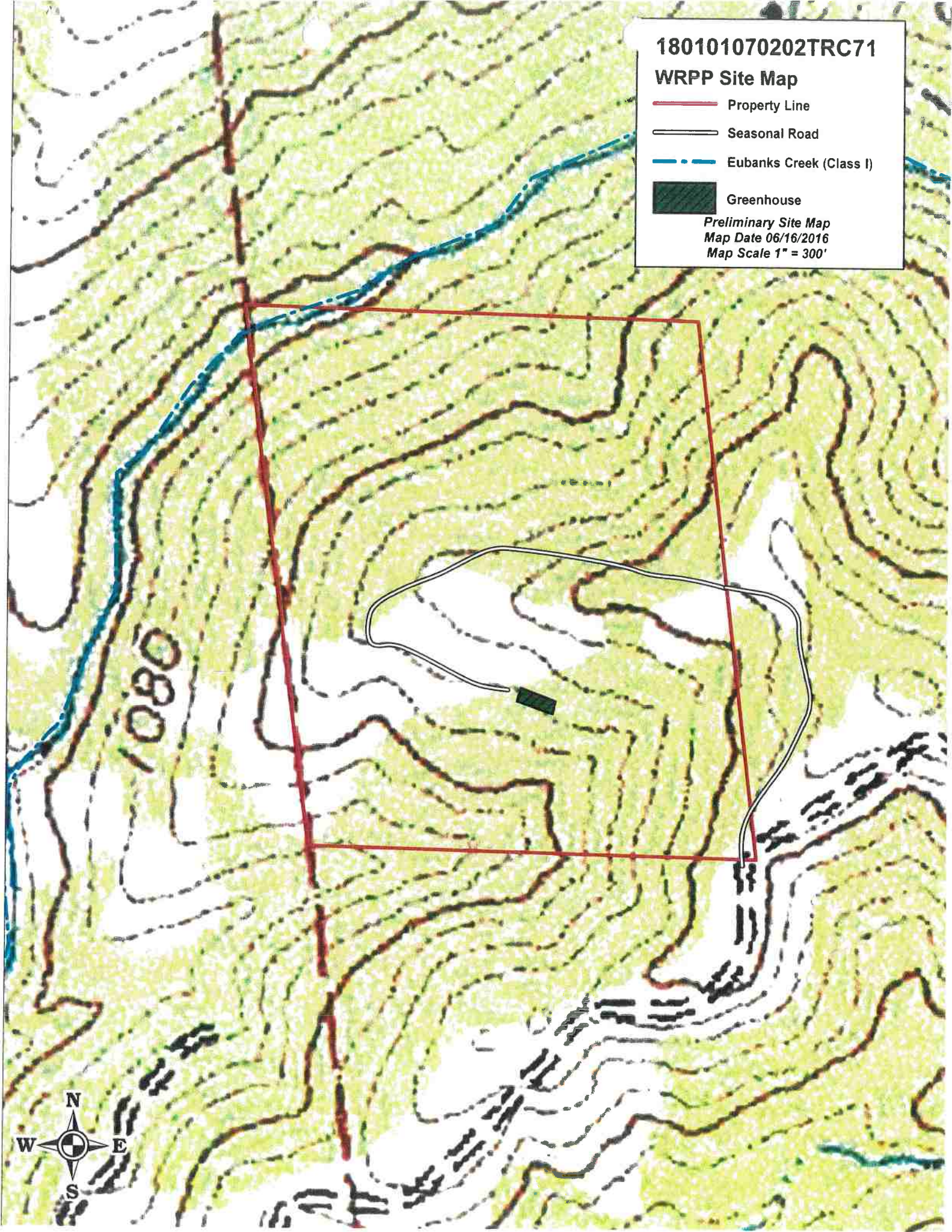



CALIFORNIA DEPARTMENT OF FISH AND WILDLIFE
REGION 1 – NORTHERN REGION
619 Second Street
Eureka, CA 95501



STREAMBED ALTERATION AGREEMENT
NOTIFICATION NO. 1600-2016-0436-R1
Unnamed Tributaries to Eubank Creek, Tributary to the Mattole River
and the Pacific Ocean

Mr. Thomas Harwood
Harwood Water Diversion and Remediation Project
4 Encroachments

This Streambed Alteration Agreement (Agreement) is entered into between the California Department of Fish and Wildlife (CDFW) and Mr. Thomas Harwood (Permittee).

RECITALS

WHEREAS, pursuant to Fish and Game Code (FGC) section 1602, the Permittee initially notified CDFW on September 7, 2016, that the Permittee intends to complete the project described herein.

WHEREAS, pursuant to FGC section 1603, CDFW has determined that the project could substantially adversely affect existing fish or wildlife resources and has included measures in the Agreement necessary to protect those resources.

WHEREAS, the Permittee has reviewed the Agreement and accept its terms and conditions, including the measures to protect fish and wildlife resources.

NOW THEREFORE, the Permittee agrees to complete the project in accordance with the Agreement.

PROJECT LOCATION

The project to be completed is located within the Eubank Creek watershed, approximately 3.2 miles southeast of the town of Ettersburg, County of Humboldt, State of California. The project is located in Section 21, T4S, R2E, Humboldt Base and Meridian; in the Briceland U.S. Geological Survey 7.5-minute quadrangle; Assessor's Parcel Number 220-081-016; latitude 40.0961 °N and longitude 123.9681 °W at the parcel center.

PROJECT DESCRIPTION

The project is limited to 4 encroachments (Table 1). Two encroachments are for water diversion from underflow in unnamed tributaries to Eubank Creek for domestic use.

Notification #1600-2016-0436-R1
 Streambed Alteration Agreement
 Page 2 of 10

Work for water diversion will include use and maintenance of existing infrastructure. One encroachment is for removal of an unused water diversion from an unnamed tributary to Eubank Creek. The last encroachment is to hydrologically disconnect and restore an erosion channel to its natural condition.

Table 1. Summary of project encroachments with descriptions.

ID	Latitude/Longitude (Decimal degrees)	Description
POD 1	40.0956, -123.9660	Use and maintain existing spring box for domestic use.
POD 2	40.0953, -123.9661	Use and maintain existing horizontal well for domestic use.
POD 3	40.0954, -123.9664	Remove existing unused water diversion infrastructure.
Sediment Discharge Point	40.09517, -123.9672	Redesign the upslope road and cultivation site to hydrologically disconnect and redirect storm water runoff. Restore erosion channel to its natural condition.

PROJECT IMPACTS

Existing fish or wildlife resources the project could substantially adversely affect include: Southern Torrent Salamanders (*Rhyacotriton variegatus*), Coastal Tailed Frog (*Ascaphus truei*), Foothill Yellow-legged Frog (*Rana boylei*), Red-bellied Newt (*Taricha rivularis*), Chinook Salmon (*Oncorhynchus tshawytscha*), Coho Salmon (*O. kisutch*), Steelhead Trout (*O. mykiss*), Pacific Lamprey (*Entosphenus tridentate*), Western Brook Lamprey (*Lampetra richardsoni*), as well as, other amphibian, reptile, aquatic invertebrate, mammal, and bird species.

The adverse effects the project could have on the fish or wildlife resources identified above include:

Impacts to water quality:

- increased water temperature;
- reduced instream flow;
- temporary increase in fine sediment transport;

Impacts to bed, channel, or bank and direct effects on fish, wildlife, and their habitat:

- loss or decline of riparian habitat;
- direct impacts on benthic organisms;

Impacts to natural flow and effects on habitat structure and process:

- cumulative effect when other diversions on the same stream are considered;
- diversion of flow from activity site;
- direct and/or incidental take;
- indirect impacts;
- impediment of up- or down-stream migration;
- water quality degradation; and
- damage to aquatic habitat and function.

Notification #1800-2016-0436-R1
Streambed Alteration Agreement
Page 3 of 10

MEASURES TO PROTECT FISH AND WILDLIFE RESOURCES

1. Administrative Measures

The Permittee shall meet each administrative requirement described below.

- 1.1 Documentation at Project Site. The Permittee shall make the Agreement, any extensions and amendments to the Agreement, and all related notification materials and California Environmental Quality Act (CEQA) documents, readily available at the project site at all times and shall be presented to CDFW personnel, or personnel from another state, federal, or local agency upon request.
- 1.2 Providing Agreement to Persons at Project Site. The Permittee shall provide copies of the Agreement and any extensions and amendments to the Agreement to all persons who will be working on the project at the project site on behalf of the Permittee, including but not limited to contractors, subcontractors, inspectors, and monitors.
- 1.3 Adherence to Existing Authorizations. All water diversion facilities that the Permittee owns, operates, or controls shall be operated and maintained in accordance with current law and applicable water rights.
- 1.4 Change of Conditions and Need to Cease Operations. If conditions arise, or change, in such a manner as to be considered deleterious by CDFW to the stream or wildlife, operations shall cease until corrective measures approved by CDFW are taken. This includes new information becoming available that indicates that the bypass flows and diversion rates provided in this agreement are not providing adequate protection to keep aquatic life downstream in good condition or to avoid "take" or "incidental take" of federal or State listed species.
- 1.5 Notification of Conflicting Provisions. The Permittee shall notify CDFW if the Permittee determines or learns that a provision in the Agreement might conflict with a provision imposed on the project by another local, state, or federal agency. In that event, CDFW shall contact the Permittee to resolve any conflict.
- 1.6 Project Site Entry. The Permittee agrees to allow CDFW employees access to any property it owns and/or manages for the purpose of inspecting and/or monitoring the activities covered by this Agreement, provided CDFW: a) provides 24 hours advance notice; and b) allows the Permittee or representatives to participate in the inspection and/or monitoring. This condition does not apply to CDFW enforcement personnel.

Notification #1600-2016-0436-R1
Streambed Alteration Agreement
Page 4 of 10

2. Avoidance and Minimization Measures

To avoid or minimize adverse impacts to fish and wildlife resources identified above, the Permittee shall implement each measure listed below.

- 2.1 Permitted Project Activities. Except where otherwise stipulated in this Agreement, all work shall be in accordance with the Permittee Notification received on September 7, 2016, together with all maps, BMP's, photographs, drawings, and other supporting documents submitted with the Notification.
- 2.2 Work Period. All work, not including water diversion, shall be confined to the period **August 1 through October 1 of 2017**. Work on stream banks or within the active channel of a stream shall be restricted to periods of **dry weather**. Precipitation forecasts and potential increases in stream flow shall be considered when planning construction activities. Construction activities shall cease and all necessary erosion control measures shall be implemented prior to the onset of precipitation.
- 2.3 Extension of the Work Period. If weather conditions permit, and the Permittee wishes to extend the work period after October 1, a written request shall be made to CDFW at least 5-working days before the proposed work period variance. Written approval (letter or e-mail) for the proposed time extension must be received from CDFW prior to activities continuing past October 1.

Water Diversion

- 2.4 Maximum Diversion Rate. The maximum instantaneous diversion rate from either POD shall not exceed 3 gallons per minute (gpm) at any time.
- 2.5 Seasonal Diversion Minimization. No more than 200 gallons per day shall be diverted from each POD during the low flow season from **May 15 to October 15 of any year**. Water shall be diverted only if the Permittee can adhere to conditions 2.4 of this Agreement.
- 2.6 Measurement of Diverted Flow. The Permittee shall install a device acceptable to CDFW for measuring the quantity of water diverted from each POD. This measurement shall begin as soon as this Agreement is signed by the Permittee. The Permittee shall record the quantity of water pumped to and from the system on a weekly basis. Alternatively, the Permittee can record the frequency of pumping and the time to fill storage.
- 2.7 Water Management Plan. The Permittee shall submit a Water Management Plan no later than June 30, 2017, that describes how compliance will be achieved under this Agreement. The Water Management Plan shall include details on water storage, water conservation, or other relevant material to maintain water needs in coordination with diversion minimization and bypass flow requirements. The Water Management Plan shall include a brief narrative describing water use on the

Notification #1600-2016-0436-R1
Streambed Alteration Agreement
Page 5 of 10

property, photographs to support the narrative, and water use calculations to ensure compliance with this Agreement. The Water Management Plan shall be submitted to CDFW at 619 Second Street, Eureka, CA 95501.

- 2.8 **Intake Structure.** No polluting materials (e.g., particle board, plastic sheeting, bentonite) shall be used to construct or screen, or cover the diversion intake structure.
- 2.9 **Intake Screening.** Screens shall be installed on intakes wherever water is diverted, and shall be in place whenever water is diverted. Openings in intakes shall not exceed 1/8 inch diameter (horizontal for slotted or square openings) or 3/32 inch for round openings. The Permittee shall regularly inspect, clean, and maintain screens in good condition.
- 2.10 **Intake Shall Not Impede Aquatic Species Passage.** The water diversion structures shall be designed, constructed, and maintained such that they do not constitute a barrier to upstream or downstream movement of aquatic life.
- 2.11 **Water Conservation.** The Permittee shall make best efforts to minimize water use, and to follow best practices for water conservation and management.
- 2.12 **Water Storage Maintenance.** Storage tanks shall have a float valve to shut off the diversion when tanks are full to prevent overflow from being diverted when not needed. The Permittee shall install any other measures necessary to prevent overflow of tanks resulting in more water being diverted than is used.
- 2.13 **State Water Code.** This Agreement does not constitute a valid water right. The Permittee shall comply with State Water Code sections 5100 and 1200 et seq. as appropriate for the water diversion and water storage. The application for this registration is found at:
http://www.swrcb.ca.gov/waterrights/publications/forms/forms/docs/sdu_registration.pdf.

Erosion Control

- 2.14 **Sediment Discharge Point.** The Permittee shall not deepen and rock line the existing erosion channel created from storm water runoff. Instead, the Permittee shall redesign (in accordance with condition 2.15) the upslope road and cultivation site to hydrologically disconnect storm water runoff. Storm water runoff shall not be directed to where it may enter the stream. The Permittee shall restore the erosion channel to its natural condition. **by October 1, 2017.**
- 2.15 **Storm water Management Plan.** The Permittee shall submit a storm water management plan for CDFW review and approval at least 60 days prior to project implementation. This plan shall include a narrative describing how the erosion channel will be remediated and how all storm water runoff will be hydrologically

Notification #1600-2016-0436-R1
Streambed Alteration Agreement
Page 6 of 10

disconnected with supporting diagrams and maps. Specifically, this plan shall address the sediment discharge point, the storm water discharged to the Class III swale from the French drain ditch, and storm water directed to Map Point 1.

- 2.16 **Runoff**. The Permittee shall not allow silt or nutrient laden runoff to enter the stream or be directed to where it may enter the stream. Erosion control measures, such as, silt fences, straw hay bales, infiltration galleries, swales, gravel or rock lined ditches, water check bars, and broadcasted weed-free straw shall be used where ever storm water runoff has the potential to enter any waterway.
- 2.17 **Runoff from Steep Areas**. Permittee shall make preparations so that runoff will be diverted into stable areas with little erosion potential or contained behind erosion control structures. Erosion control structures such as straw bales and/or siltation control fencing shall be placed and maintained until the threat of erosion ceases.
- 2.18 **Erosion Control Maintenance**. Permittee shall periodically monitor and make modifications, repairs and improvements to erosion control measures whenever it is needed.
- 2.19 **Rock Armor Placement**
- 2.19.1 No heavy equipment shall enter the wetted stream channel.
- 2.19.2 No fill material, other than clean rock, shall be placed in the stream channel.
- 2.19.3 Rock shall be sized to withstand washout from high stream flows, and extend above the ordinary high water level.
- 2.19.4 Rock armoring shall not constrict the natural stream channel width and shall be keyed into a footing trench with a depth sufficient to prevent instability.
- 2.20 **Project Inspection**. All projects shall be inspected by Timberland Resource Consulting or a licensed engineer to ensure that the proposed project was implemented as designed. The inspection report shall include photographs of the site and shall be submitted to CDFW within 90 days of project completion.
3. **Reporting Measures**
- 3.1 **Measurement of Diverted Flow**. Copies of the water diversion records (measure 2.6) shall be submitted to CDFW at 619 Second Street, Eureka, CA 95501 no later than December 31 of each year beginning in 2017.
- 3.2 **Water Management Plan**. The Permittee shall submit a Water Management Plan (measure 2.7) no later than June 30, 2017, that describes how compliance will be achieved under this Agreement. The Water Management Plan shall be submitted to CDFW at the 619 Second Street, Eureka, CA 95501.

Notification #1600-2016-0436-R1
Streambed Alteration Agreement
Page 7 of 10

3.3 Project Inspection. The Permittee shall submit the Project Inspection Report (measure 2.20) to CDFW, LSA Program at 619 Second Street, Eureka, CA 95501, within 90 days following project completion.

CONTACT INFORMATION

Written communication that the Permittee or CDFW submits to the other shall be delivered to the address below unless the Permittee or CDFW specifies otherwise.

To Permittee:

Mr. Thomas Harwood
P.O. Box 264
Redway, California 95560
707-362-0156

To CDFW:

Department of Fish and Wildlife
Northern Region
619 Second Street
Eureka, California 95501
Attn: Lake and Streambed Alteration Program
Notification #1600-2016-0436-R1

LIABILITY

The Permittee shall be solely liable for any violation of the Agreement, whether committed by the Permittee or any person acting on behalf of the Permittee, including its officers, employees, representatives, agents or contractors and subcontractors, to complete the project or any activity related to it that the Agreement authorizes.

This Agreement does not constitute CDFW's endorsement of, or require the Permittee to proceed with the project. The decision to proceed with the project is the Permittee's alone.

SUSPENSION AND REVOCATION

CDFW may suspend or revoke in its entirety this Agreement if it determines that the Permittee or any person acting on behalf of the Permittee, including its officers, employees, representatives, agents, or contractors and subcontractors, is not in compliance with the Agreement.

Before CDFW suspends or revokes the Agreement, it shall provide the Permittee written notice by certified or registered mail that it intends to suspend or revoke. The notice

Notification #1600-2016-0436-R1
Streambed Alteration Agreement
Page 8 of 10

shall state the reason(s) for the proposed suspension or revocation, provide the Permittee an opportunity to correct any deficiency before CDFW suspends or revokes the Agreement, and include instructions to the Permittee, if necessary, including but not limited to a directive to immediately cease the specific activity or activities that caused CDFW to issue the notice.

ENFORCEMENT

Nothing in the Agreement precludes CDFW from pursuing an enforcement action against the Permittee instead of, or in addition to, suspending or revoking the Agreement.

Nothing in the Agreement limits or otherwise affects CDFW's enforcement authority or that of its enforcement personnel.

OTHER LEGAL OBLIGATIONS

This Agreement does not relieve the Permittee or any person acting on behalf of the Permittee, including its officers, employees, representatives, agents, or contractors and subcontractors, from obtaining any other permits or authorizations that might be required under other federal, state, or local laws or regulations before beginning the project or an activity related to it.

This Agreement does not relieve the Permittee or any person acting on behalf of the Permittee, including its officers, employees, representatives, agents, or contractors and subcontractors, from complying with other applicable statutes in the FGC including, but not limited to, FGC sections 2050 *et seq.* (threatened and endangered species), 3503 (bird nests and eggs), 3503.5 (birds of prey), 5650 (water pollution), 5652 (refuse disposal into water), 5901 (fish passage), 5937 (sufficient water for fish), and 5948 (obstruction of stream).

Nothing in the Agreement authorizes the Permittee or any person acting on behalf of the Permittee, including its officers, employees, representatives, agents, or contractors and subcontractors, to trespass.

AMENDMENT

CDFW may amend the Agreement at any time during its term if CDFW determines the amendment is necessary to protect an existing fish or wildlife resource.

The Permittee may amend the Agreement at any time during its term, provided the amendment is mutually agreed to in writing by CDFW and the Permittee. To request an amendment, the Permittee shall submit to CDFW a completed CDFW "Request to Amend Lake or Streambed Alteration" form and include with the completed form

Notification #1600-2016-0436-R1
Streambed Alteration Agreement
Page 9 of 10

payment of the corresponding amendment fee identified in CDFW's current fee schedule (see Cal. Code Regs., tit. 14, § 699.5).

TRANSFER AND ASSIGNMENT

This Agreement may not be transferred or assigned to another entity, and any purported transfer or assignment of the Agreement to another entity shall not be valid or effective, unless the transfer or assignment is requested by the Permittee in writing, as specified below, and thereafter CDFW approves the transfer or assignment in writing.

The transfer or assignment of the Agreement to another entity shall constitute a minor amendment, and therefore to request a transfer or assignment, the Permittee shall submit to CDFW a completed CDFW "Request to Amend Lake or Streambed Alteration" form and include with the completed form payment of the minor amendment fee identified in CDFW's current fee schedule (see Cal. Code Regs., tit. 14, § 699.5).

EXTENSIONS

In accordance with FGC section 1605(b), the Permittee may request one extension of the Agreement, provided the request is made prior to the expiration of the Agreement's term. To request an extension, the Permittee shall submit to CDFW a completed CDFW "Request to Extend Lake or Streambed Alteration" form and include with the completed form payment of the extension fee identified in CDFW's current fee schedule (see Cal. Code Regs., tit. 14, § 699.5). CDFW shall process the extension request in accordance with FGC 1605(b) through (e).

If the Permittee fails to submit a request to extend the Agreement prior to its expiration, the Permittee must submit a new notification and notification fee before beginning or continuing the project the Agreement covers (FGC section 1605(f)).

EFFECTIVE DATE

The Agreement becomes effective on the date of CDFW's signature, which shall be: 1) after the Permittee signature; 2) after CDFW complies with all applicable requirements under the California Environmental Quality Act (CEQA); and 3) after payment of the applicable FGC section 711.4 filing fee listed at http://www.wildlife.ca.gov/habcon/ceqa/ceqa_changes.html.

TERM

This Agreement shall **expire five years** from date of execution, unless it is terminated or extended before then. All provisions in the Agreement shall remain in force throughout its term. The Permittee shall remain responsible for implementing any provisions specified herein to protect fish and wildlife resources after the Agreement expires or is terminated, as FGC section 1605(a)(2) requires.

Notification #1600-2016-0436-R1
Streambed Alteration Agreement
Page 10 of 10

AUTHORITY

If the person signing the Agreement (signatory) is doing so as a representative of the Permittee, the signatory hereby acknowledges that he or she is doing so on the Permittee's behalf and represents and warrants that he or she has the authority to legally bind the Permittee to the provisions herein.

AUTHORIZATION

This Agreement authorizes only the project described herein. If the Permittee begins or completes a project different from the project the Agreement authorizes, the Permittee may be subject to civil or criminal prosecution for failing to notify CDFW in accordance with FGC section 1602.

CONCURRENCE

The undersigned accepts and agrees to comply with all provisions contained herein.

FOR Mr. Thomas Harwood



Thomas Harwood

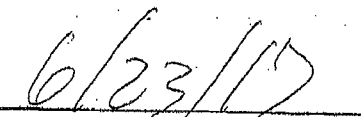

Date

FOR DEPARTMENT OF FISH AND WILDLIFE

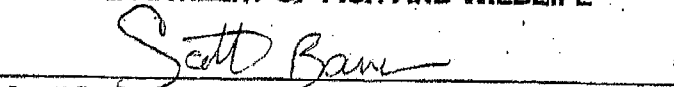

Scott Bauer
Senior Environmental Scientist Supervisor

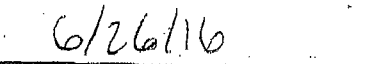

Date

COPY

FOR DEPARTMENT USE ONLY				
DATE RECEIVED	APPROVAL TYPE	APPROVAL DATE	APPROVAL OFFICER	APPROVAL SIGNATURE



STATE OF CALIFORNIA
 DEPARTMENT OF FISH AND WILDLIFE
NOTIFICATION OF LAKE OR STREAMBED ALTERATION



Complete EACH field, unless otherwise indicated, following the enclosed instructions and submit ALL required enclosures. Attach additional pages, if necessary.

1. APPLICANT PROPOSING PROJECT

Name	THOMAS HARWOOD		
Business/Agency			
Street Address	PO BOX 264		
City, State, Zip	REDWAY CA 95560		
Telephone	707-362-0156	Fax	
Email			

2. CONTACT PERSON *(Complete only if different from applicant)*

Name	Chris Carroll		
Street Address	165 S. Fortuna Blvd.		
City, State, Zip	Fortuna, CA, 95540		
Telephone	707-725-1897	Fax	
Email	carroll@timberlandresource.com		

3. PROPERTY OWNER *(Complete only if different from applicant)*

Name	THOMAS & CHRISTINA HARWOOD		
Street Address	PO BOX 264		
City, State, Zip	REDWAY CA 95560		
Telephone	707-362-0156	Fax	
Email			

4. PROJECT NAME AND AGREEMENT TERM

A. Project Name		APN 220-081-016		
B. Agreement Term Requested		<input checked="" type="checkbox"/> Regular (5 years or less) <input type="checkbox"/> Long-term (greater than 5 years)		
C. Project Term		D. Seasonal Work Period		E. Number of Work Days
Beginning (year)	Ending (year)	Start Date (month/day)	End Date (month/day)	

NOTIFICATION OF LAKE OR STREAMBED ALTERATION

5. AGREEMENT TYPE

Check the applicable box. If box B, C, D, or E is checked, complete the specified attachment.

A.	<input checked="" type="checkbox"/> Standard (Most construction projects, excluding the categories listed below)	
B.	<input type="checkbox"/> Gravel/Sand/Rock Extraction (Attachment A)	Mine I.D. Number: _____
C.	<input type="checkbox"/> Timber Harvesting (Attachment B)	THP Number: _____
D.	<input checked="" type="checkbox"/> Water Diversion/Extraction/Impoundment (Attachment C)	SWRCB Number: _____
E.	<input type="checkbox"/> Routine Maintenance (Attachment D)	
F.	<input type="checkbox"/> CDFW Fisheries Restoration Grant Program (FRGP)	FRGP Contract Number _____
G.	<input type="checkbox"/> Master	
H.	<input type="checkbox"/> Master Timber Harvesting	

6. FEES

Please see the current fee schedule to determine the appropriate notification fee. Itemize each project's estimated cost and corresponding fee. **Note: The Department may not process this notification until the correct fee has been received.**

A. Project		B. Project Cost	C. Project Fee
1	Surface Water Diversion	~\$5k	\$245.50
2			
3			
4			
5			
		D. Base Fee (if applicable)	
		E. TOTAL FEE ENCLOSED	\$245.50

7. PRIOR NOTIFICATION OR ORDER

A. Has a notification previously been submitted to, or a Lake or Streambed Alteration Agreement previously been issued by, the Department for the project described in this notification?

Yes (Provide the information below) No

Applicant: _____ Notification Number: _____ Date: _____

B. Is this notification being submitted in response to an order, notice, or other directive ("order") by a court or administrative agency (including the Department)?

No Yes (Enclose a copy of the order, notice, or other directive. If the directive is not in writing, identify the person who directed the applicant to submit this notification and the agency he or she represents, and describe the circumstances relating to the order.)

Continued on additional page(s)

NOTIFICATION OF LAKE OR STREAMBED ALTERATION

8. PROJECT LOCATION

A. Address or description of project location.

(Include a map that marks the location of the project with a reference to the nearest city or town, and provide driving directions from a major road or highway)

569 EUBANKS ROAD, BRICELAND CA

Continued on additional page(s)

B. River, stream, or lake affected by the project. Unnamed Class III watercourse

C. What water body is the river, stream, or lake tributary to? Eubank Creek - Mattole River

D. Is the river or stream segment affected by the project listed in the state or federal Wild and Scenic Rivers Acts? Yes No Unknown

E. County Humboldt County

F. USGS 7.5 Minute Quad Map Name	G. Township	H. Range	I. Section	J. ¼ Section
Briceland, CA	4S	2E	21	SW

Continued on additional page(s)

K. Meridian (check one) Humboldt Mt. Diablo San Bernardino

L. Assessor's Parcel Number(s)

220-081-016

Continued on additional page(s)

M. Coordinates (If available, provide at least latitude/longitude or UTM coordinates and check appropriate boxes)

Latitude/Longitude	Latitude: -123.9659778°		Longitude: 40.09563281°	
	<input type="checkbox"/> Degrees/Minutes/Seconds	<input checked="" type="checkbox"/> Decimal Degrees	<input type="checkbox"/> Decimal Minutes	
UTM	Easting:	Northing:	<input type="checkbox"/> Zone 10	<input type="checkbox"/> Zone 11
Datum used for Latitude/Longitude or UTM		<input type="checkbox"/> NAD 27	<input checked="" type="checkbox"/> NAD 83 or WGS 84	

NOTIFICATION OF LAKE OR STREAMBED ALTERATION

9. PROJECT CATEGORY AND WORK TYPE (Check each box that applies)

PROJECT CATEGORY	NEW CONSTRUCTION	REPLACE EXISTING STRUCTURE	REPAIR/MAINTAIN EXISTING STRUCTURE
Bank stabilization – bioengineering/recontouring	<input type="checkbox"/>	<input type="checkbox"/>	<input type="checkbox"/>
Bank stabilization – rip-rap/retaining wall/gabion	<input type="checkbox"/>	<input type="checkbox"/>	<input type="checkbox"/>
Boat dock/pier	<input type="checkbox"/>	<input type="checkbox"/>	<input type="checkbox"/>
Boat ramp	<input type="checkbox"/>	<input type="checkbox"/>	<input type="checkbox"/>
Bridge	<input type="checkbox"/>	<input type="checkbox"/>	<input type="checkbox"/>
Channel clearing/vegetation management	<input type="checkbox"/>	<input type="checkbox"/>	<input type="checkbox"/>
Culvert	<input type="checkbox"/>	<input type="checkbox"/>	<input type="checkbox"/>
Debris basin	<input type="checkbox"/>	<input type="checkbox"/>	<input type="checkbox"/>
Dam	<input type="checkbox"/>	<input type="checkbox"/>	<input type="checkbox"/>
Diversion structure – weir or pump intake	<input type="checkbox"/>	<input type="checkbox"/>	<input checked="" type="checkbox"/>
Filling of wetland, river, stream, or lake	<input type="checkbox"/>	<input type="checkbox"/>	<input type="checkbox"/>
Geotechnical survey	<input type="checkbox"/>	<input type="checkbox"/>	<input type="checkbox"/>
Habitat enhancement – revegetation/mitigation	<input type="checkbox"/>	<input type="checkbox"/>	<input type="checkbox"/>
Levee	<input type="checkbox"/>	<input type="checkbox"/>	<input type="checkbox"/>
Low water crossing	<input type="checkbox"/>	<input type="checkbox"/>	<input type="checkbox"/>
Road/trail	<input type="checkbox"/>	<input type="checkbox"/>	<input type="checkbox"/>
Sediment removal – pond, stream, or marina	<input type="checkbox"/>	<input type="checkbox"/>	<input type="checkbox"/>
Storm drain outfall structure	<input type="checkbox"/>	<input type="checkbox"/>	<input type="checkbox"/>
Temporary stream crossing	<input type="checkbox"/>	<input type="checkbox"/>	<input type="checkbox"/>
Utility crossing : Horizontal Directional Drilling	<input type="checkbox"/>	<input type="checkbox"/>	<input type="checkbox"/>
Jack/bore	<input type="checkbox"/>	<input type="checkbox"/>	<input type="checkbox"/>
Open trench	<input type="checkbox"/>	<input type="checkbox"/>	<input type="checkbox"/>
Other (specify):	<input type="checkbox"/>	<input type="checkbox"/>	<input type="checkbox"/>

NOTIFICATION OF LAKE OR STREAMBED ALTERATION

10. PROJECT DESCRIPTION

A. Describe the project in detail. Photographs of the project location and immediate surrounding area should be included.

- Include any structures (e.g., rip-rap, culverts, or channel clearing) that will be placed, built, or completed in or near the stream, river, or lake.
- Specify the type and volume of materials that will be used.
- If water will be diverted or drafted, specify the purpose or use.

Enclose diagrams, drawings, plans, and/or maps that provide all of the following: site specific construction details; the dimensions of each structure and/or extent of each activity in the bed, channel, bank or floodplain; an overview of the entire project area (i.e., "bird's-eye view") showing the location of each structure and/or activity, significant area features, and where the equipment/machinery will enter and exit the project area.

See Addendum 10

Continued on additional page(s)

B. Specify the equipment and machinery that will be used to complete the project.

No construction proposed.

Continued on additional page(s)

C. Will water be present during the proposed work period (specified in box 4.D) in the stream, river, or lake (specified in box 8.B).

Yes No (Skip to box 11)

D. Will the proposed project require work in the wetted portion of the channel?

Yes (Enclose a plan to divert water around work site)
 No

NOTIFICATION OF LAKE OR STREAMBED ALTERATION

11. PROJECT IMPACTS

A. Describe impacts to the bed, channel, and bank of the river, stream, or lake, and the associated riparian habitat. Specify the dimensions of the modifications in length (linear feet) and area (square feet or acres) and the type and volume of material (cubic yards) that will be moved, displaced, or otherwise disturbed, if applicable.

No construction proposed.

Continued on additional page(s)

B. Will the project affect any vegetation?

Yes (Complete the tables below) No

Vegetation Type	Temporary Impact	Permanent Impact
	Linear feet: _____ Total area: _____	Linear feet: _____ Total area: _____
	Linear feet: _____ Total area: _____	Linear feet: _____ Total area: _____

Tree Species	Number of Trees to be Removed	Trunk Diameter (range)

Continued on additional page(s)

C. Are any special status animal or plant species, or habitat that could support such species, known to be present on or near the project site?

Yes (List each species and/or describe the habitat below) No Unknown

Anadromous salmonids occur in Eubank Creek.

Continued on additional page(s)

D. Identify the source(s) of information that supports a "yes" or "no" answer above in Box 11.C.

CNDDDB

Continued on additional page(s)

E. Has a biological study been completed for the project site?

Yes (Enclose the biological study) No

Note: A biological assessment or study may be required to evaluate potential project impacts on biological resources.

F. Has a hydrological study been completed for the project or project site?

Yes (Enclose the hydrological study) No

Note: A hydrological study or other information on site hydraulics (e.g., flows, channel characteristics, and/or flood recurrence intervals) may be required to evaluate potential project impacts on hydrology.

NOTIFICATION OF LAKE OR STREAMBED ALTERATION

12. MEASURES TO PROTECT FISH, WILDLIFE, AND PLANT RESOURCES

A. Describe the techniques that will be used to prevent sediment from entering watercourses during and after construction.

No construction proposed.

Continued on additional page(s)

B. Describe project avoidance and/or minimization measures to protect fish, wildlife, and plant resources.

This notification proposes forbearance for diversion for agricultural use.

Continued on additional page(s)

C. Describe any project mitigation and/or compensation measures to protect fish, wildlife, and plant resources.

As prescribed by CDFW

Continued on additional page(s)

13. PERMITS

List any local, state, and federal permits required for the project and check the corresponding box(es). Enclose a copy of each permit that has been issued.

- A. Humboldt County Ordinance 2544 (Application Applied Issued
- B. submitted and pending County Review) Applied Issued
- C. _____ Applied Issued
- D. Unknown whether local, state, or federal permit is needed for the project. (Check each box that applies)

Continued on additional page(s)

NOTIFICATION OF LAKE OR STREAMBED ALTERATION

14. ENVIRONMENTAL REVIEW

A. Has a draft or final document been prepared for the project pursuant to the California Environmental Quality Act (CEQA), National Environmental Protection Act (NEPA), California Endangered Species Act (CESA) and/or federal Endangered Species Act (ESA)?	
<input checked="" type="checkbox"/> Yes (Check the box for each CEQA, NEPA, CESA, and ESA document that has been prepared and enclose a copy of each) <input type="checkbox"/> No (Check the box for each CEQA, NEPA, CESA, and ESA document listed below that will be or is being prepared)	
<input type="checkbox"/> Notice of Exemption <input type="checkbox"/> Initial Study <input type="checkbox"/> Negative Declaration <input type="checkbox"/> THP/ NTMP	<input checked="" type="checkbox"/> Mitigated Negative Declaration <input type="checkbox"/> Environmental Impact Report <input type="checkbox"/> Notice of Determination (Enclose) <input type="checkbox"/> Mitigation, Monitoring, Reporting Plan <input type="checkbox"/> NEPA document (type): _____ <input type="checkbox"/> CESA document (type): _____ <input type="checkbox"/> ESA document (type): _____
B. State Clearinghouse Number (if applicable)	No. 2015042074
C. Has a CEQA lead agency been determined?	<input checked="" type="checkbox"/> Yes (Complete boxes D, E, and F) <input type="checkbox"/> No (Skip to box 14.G)
D. CEQA Lead Agency	California Regional Water Quality Control Board North Coast Region
E. Contact Person	Mathias St. John, Executive Officer
F. Telephone Number	707-570-3762
G. If the project described in this notification is part of a larger project or plan, briefly describe that larger project or plan.	
<p>See Addendum 10's discussion of California Regional Water Quality Control Board North Coast Region Order No. 2015-0023, Waiver of Waste Discharge Requirements and General Water Quality Certification for Discharges of Waste Resulting from Cannabis Cultivation and associated Activities or Operations with Similar Environmental Effects in the North Coast Region. The Applicant is enrolled in TRC's Third Party Program (TRC ID# 180101070202TRC71 & WDID# 1B16459CHUM).</p> <p align="right"><input type="checkbox"/> Continued on additional page(s)</p>	
H. Has an environmental filing fee (Fish and Game Code section 711.4) been paid?	
<input type="checkbox"/> Yes (Enclose proof of payment) <input checked="" type="checkbox"/> No (Briefly explain below the reason a filing fee has not been paid)	
<p><i>Note: If a filing fee is required, the Department may not finalize a Lake or Streambed Alteration Agreement until the filing fee is paid.</i></p>	

15. SITE INSPECTION

Check one box only.
<input type="checkbox"/> In the event the Department determines that a site inspection is necessary, I hereby authorize a Department representative to enter the property where the project described in this notification will take place at any reasonable time, and hereby certify that I am authorized to grant the Department such entry.
<input checked="" type="checkbox"/> I request the Department to first contact (insert name) <u>Chris Carroll</u> at (insert telephone number) <u>707-175-1897</u> to schedule a date and time to enter the property where the project described in this notification will take place. I understand that this may delay the Department's determination as to whether a Lake or Streambed Alteration Agreement is required and/or the Department's issuance of a draft agreement pursuant to this notification.

NOTIFICATION OF LAKE OR STREAMBED ALTERATION

16. DIGITAL FORMAT

Is any of the information included as part of the notification available in digital format (i.e., CD, DVD, etc.)?
<input type="checkbox"/> Yes (Please enclose the information via digital media with the completed notification form)
<input checked="" type="checkbox"/> No

17. SIGNATURE

I hereby certify that to the best of my knowledge the information in this notification is true and correct and that I am authorized to sign this notification as, or on behalf of, the applicant. I understand that if any information in this notification is found to be untrue or incorrect, the Department may suspend processing this notification or suspend or revoke any draft or final Lake or Streambed Alteration Agreement issued pursuant to this notification. I understand also that if any information in this notification is found to be untrue or incorrect and the project described in this notification has already begun, I and/or the applicant may be subject to civil or criminal prosecution. I understand that this notification applies only to the project(s) described herein and that I and/or the applicant may be subject to civil or criminal prosecution for undertaking any project not described herein unless the Department has been separately notified of that project in accordance with Fish and Game Code section 1602 or 1611.

Chris Carroll
Signature of Applicant or Applicant's Authorized Representative

9-6-16
Date

Chris Carroll
Print Name

APN 220-081-016

Location Map

 **Property Boundary**

Map Scale 1 inch = 2,000 feet
Section 21, T4S, R2E, HB&M
Briceland USGS 7.5' Quad. C.I. = 40 feet



APN 220-081-016

1600 Map



Map Scale 1 inch = 200 feet
Section 21, T4S, R2E, HB&M
Briceland USGS 7.5' Quad. C.I. = 40 feet

Property Boundary

Point of Diversion

Water Tank

Tank Farm

Groundwater Well

Other Structure

Residence

Agricultural Greenhouse

Outdoor Agricultural Garden

Class III Watercourse

Class II Watercourse

Seasonal Dirt Road

Permanent Rock Road

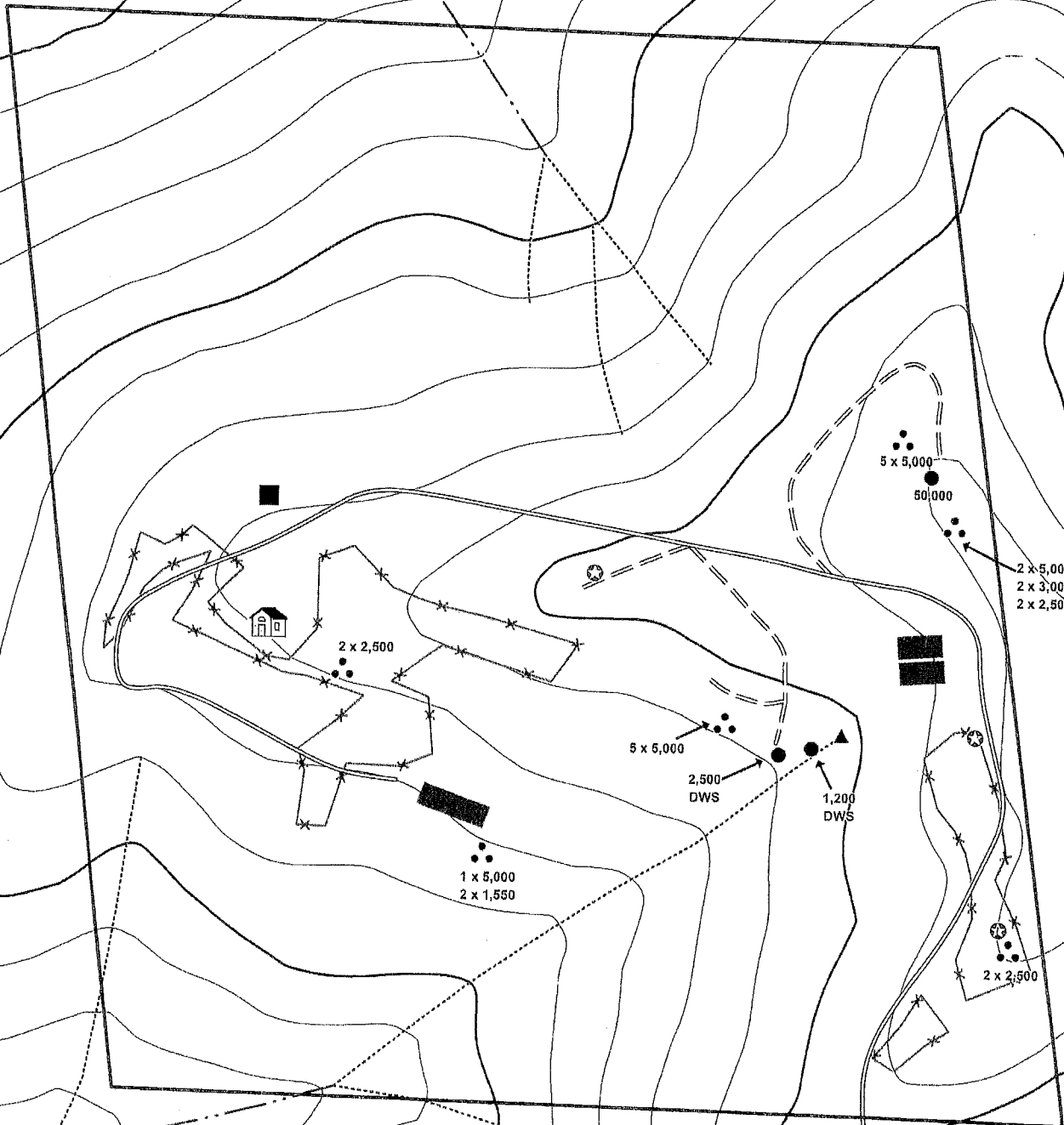

APN 220-081-016

1600 2014 DOQ

NORTH

Map Scale 1 inch = 200 feet
Section 21, T4S, R2E, HB&M
Briceland USGS 7.5' Quad. C.I. = 40 feet

 Property Boundary

 Point of Diversion

 Water Tank

 Tank Farm

 Groundwater Well

 Other Structure

 Residence

 Agricultural Greenhouse

 Outdoor Agricultural Garden

 Class III Watercourse

 Class II Watercourse

 Seasonal Dirt Road

 Permanent Rock Road

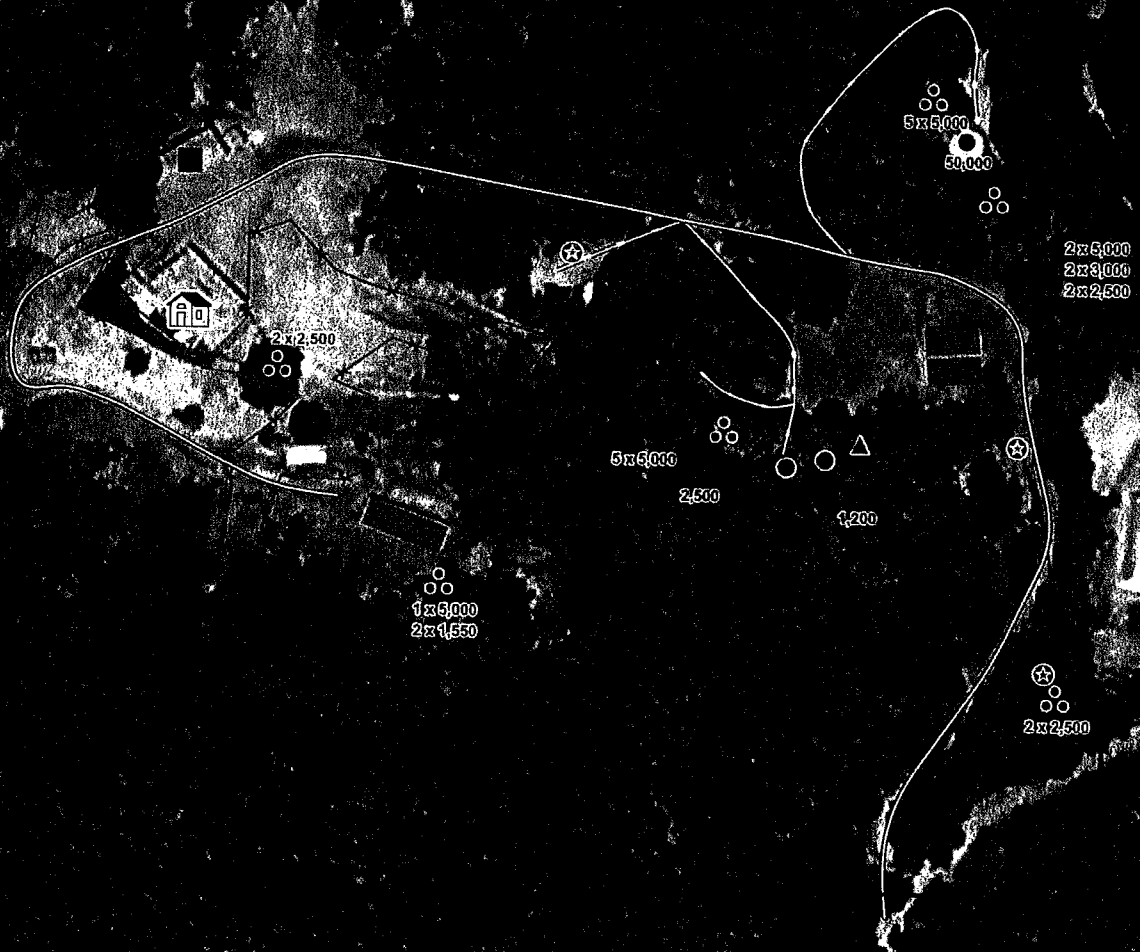

APN 220-081-016

1600 USGS Map

NORTH

Map Scale 1 Inch = 200 feet
Section 21, T4S, R2E, HB&M
Briceland USGS 7.5' Quad, C.I. = 40 feet

Property Boundary

Point of Diversion

Water Tank

Tank Farm

Groundwater Well

Other Structure

Residence

Agricultural Greenhouse

Outdoor Agricultural Garden

Class III Watercourse

Class II Watercourse

Seasonal Dirt Road

Permanent Rock Road

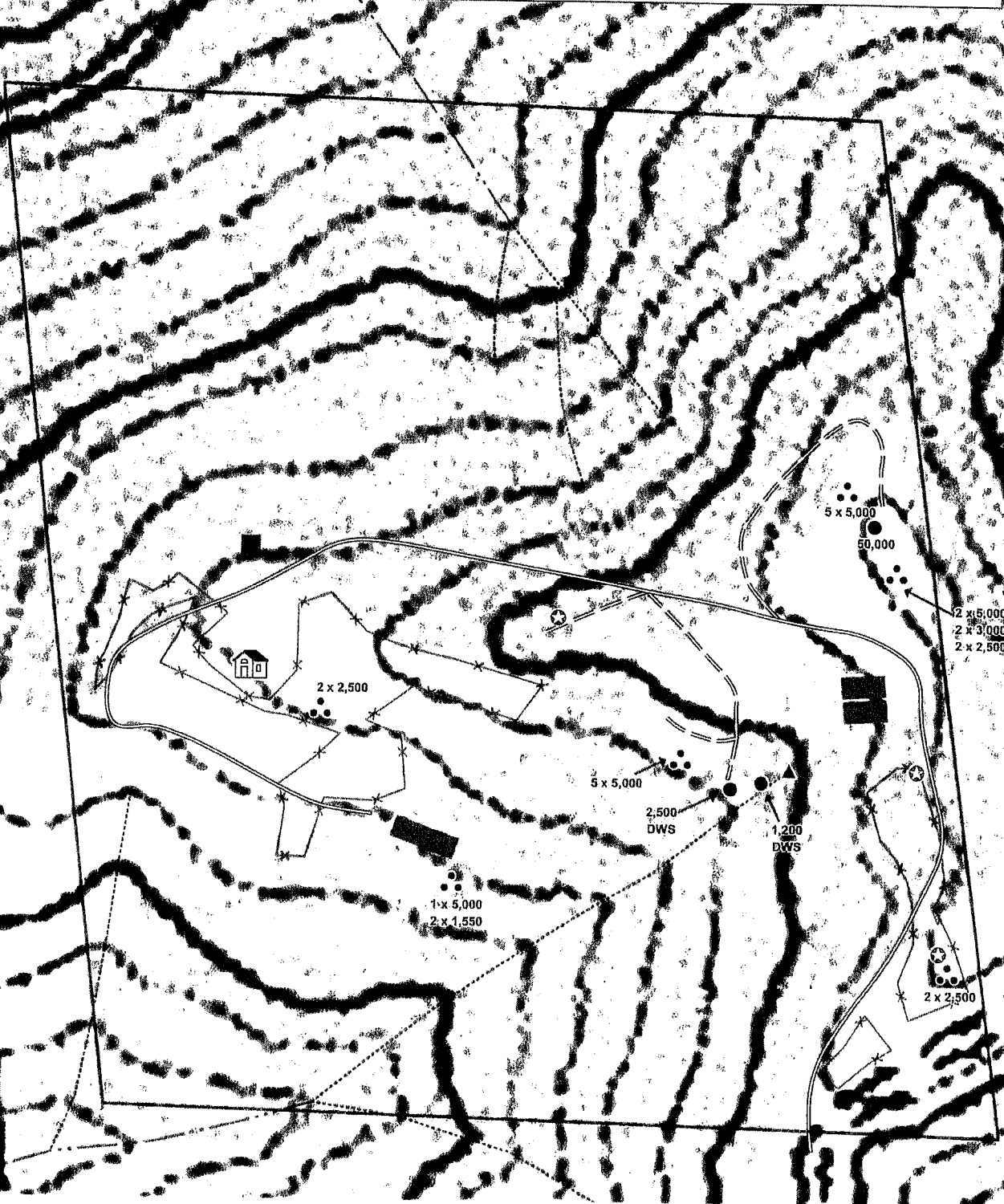

Addendum 10A – Project Description

POD: This is an existing diversion from a spring located at the head of a Class III watercourse that is tributary to Eubank Creek. The diversion works is a wooden spring box approximately 2.5 feet square and 1 foot deep. Diverted water is gravity fed via ¾-inch poly pipe down to a 2,500 gallon tank. Diverted water is pumped upslope to the 50,000 pioneer tank shown in Picture 10. This notification proposes to allow direct diversion for domestic use only at 200 gallons of water per day.

Water Use and Storage: The landowner has three permitted wells, which are plumbed to twenty-five hard plastic tanks (90,000 gallons of total storage capacity) located throughout the property that area dedicated to agriculture. The 50,000 gallon pioneer tank is dedicated to domestic use. The landowner presently has 57,100 ft² of existing cultivation consisting of 20,500 ft² mixed light, 1,800 ft² indoor and 34,800 ft² outdoor. These figures are from the attached plot plan titled "CULTIVATION SITE IMPROVEMENTS". At 1.4 gallons of water per 10 ft² for the outdoor and 0.75 gallons of water per 10 ft² for the mixed light, total water use is approximately 8,000 gallons of water per day. Please note that in the absence of water meter data this is a rough estimate.

The landowner is enrolled into *California Regional Water Quality Control Board North Coast Region Order No. 2015-0023, Waiver of Waste Discharge Requirements and General Water Quality Certification for Discharges of Waste Resulting from Cannabis Cultivation and Associated Activities or Operations with Similar Environmental Effects In the North Coast Region*, by Timberland Resource Consultants, Inc (Site WDID: 1B16459CHUM & Third Party ID: 180101070202TRC71).

All roads and developed sites were assessed for compliance with CDFW, which includes jurisdictional 1600 sites and potential California Fish and Game Code Section 5650 violations. TRC will be conducting a thorough field assessment to evaluate compliance with the Standard Conditions per Provision I.B of Order No. R1-2015-0023. Based upon my evaluation conducted in association with this notification, the assessment conducted for the preparation of the water resource protection plan is not expected to include any sites that are jurisdictional to CDFW per the California Fish and Game Code 1600 that should otherwise be included in this notification. There is one *potential* Section 5650 violation on the property. This site is disclosed in this notification, and shall be included in the Water Resource Protection Plan for restoration and remediation.

Addendum 10 – Pictures



Picture 1: POD. Photo date 8-25-2016.

Addendum 10 – Pictures (Cont.)



Picture 2: This is a photograph looking upslope of the POD. Photo date 8-25-2016.

Addendum 10 – Pictures (Cont.)



Picture 3: The POD is in background at base of tanoaks above the ferns with 1,200 gallon plastic tank that is not in use. Photo date 8-25-2016.

Addendum 10 – Pictures (Cont.)



Picture 4: The 2,500 gallon plastic tank pictured above is located directly below the 1,200 gallon tank in Picture 3. The inside ditch of this road is hydrologically connected to the watercourse in the distance. This ditch shall be disconnected from the watercourse via a series of drainage structures, which have yet to be specifically determined at this point but will be further addressed in the Water Resource Protection Plan upon re-visiting the site this winter. Photo date 8-25-2016.

Addendum 10 – Pictures (Cont.)

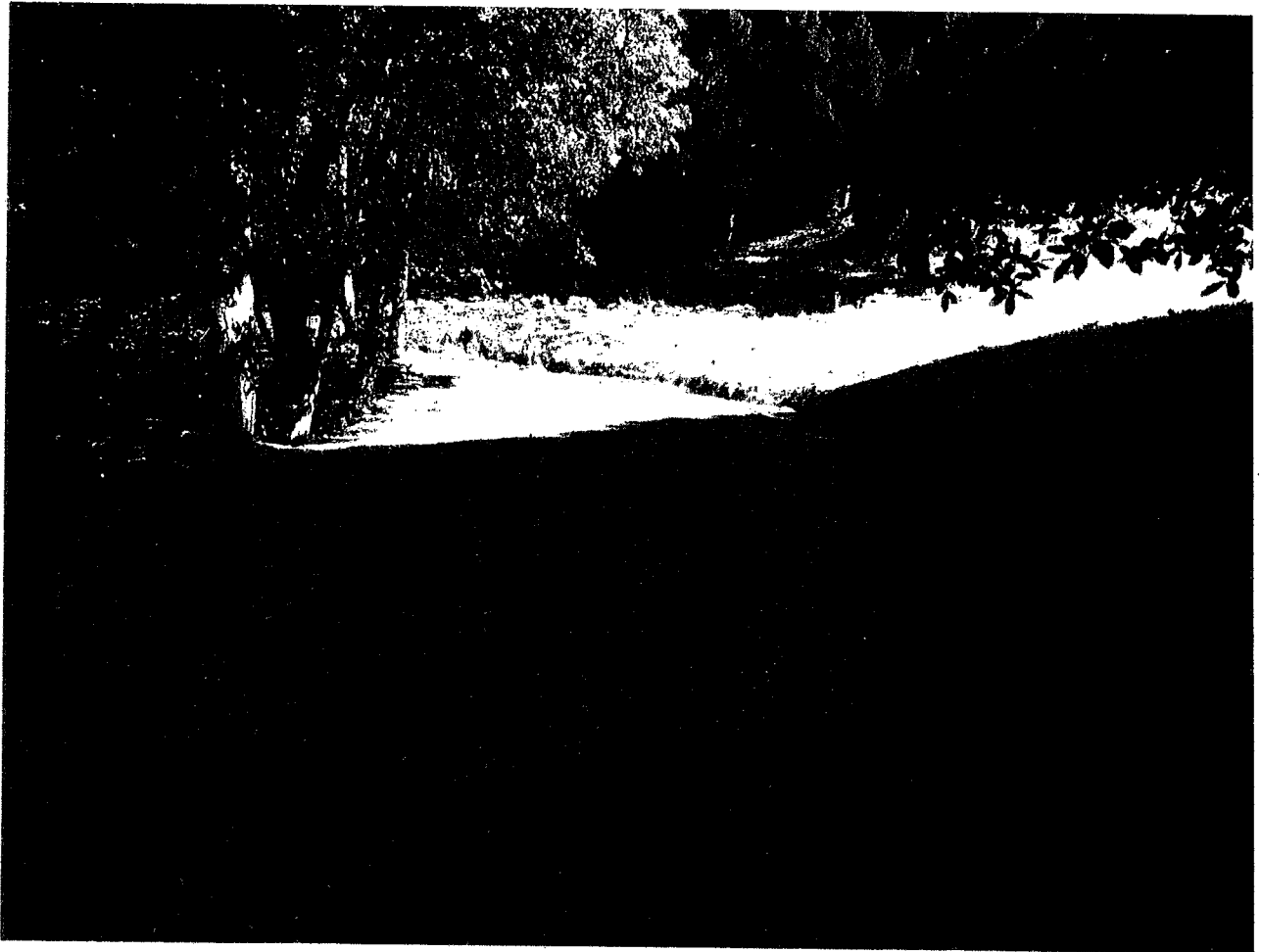

Picture 5: Inside ditch that is contributing sediment to the watercourse below POD. Photo date 8-25-2016.

Addendum 10 – Pictures (Cont.)



Picture 6: Erosion of fill material from the long and uninterrupted inside ditch. Photo date 8-25-2016.

Addendum 10 – Pictures (Cont.)

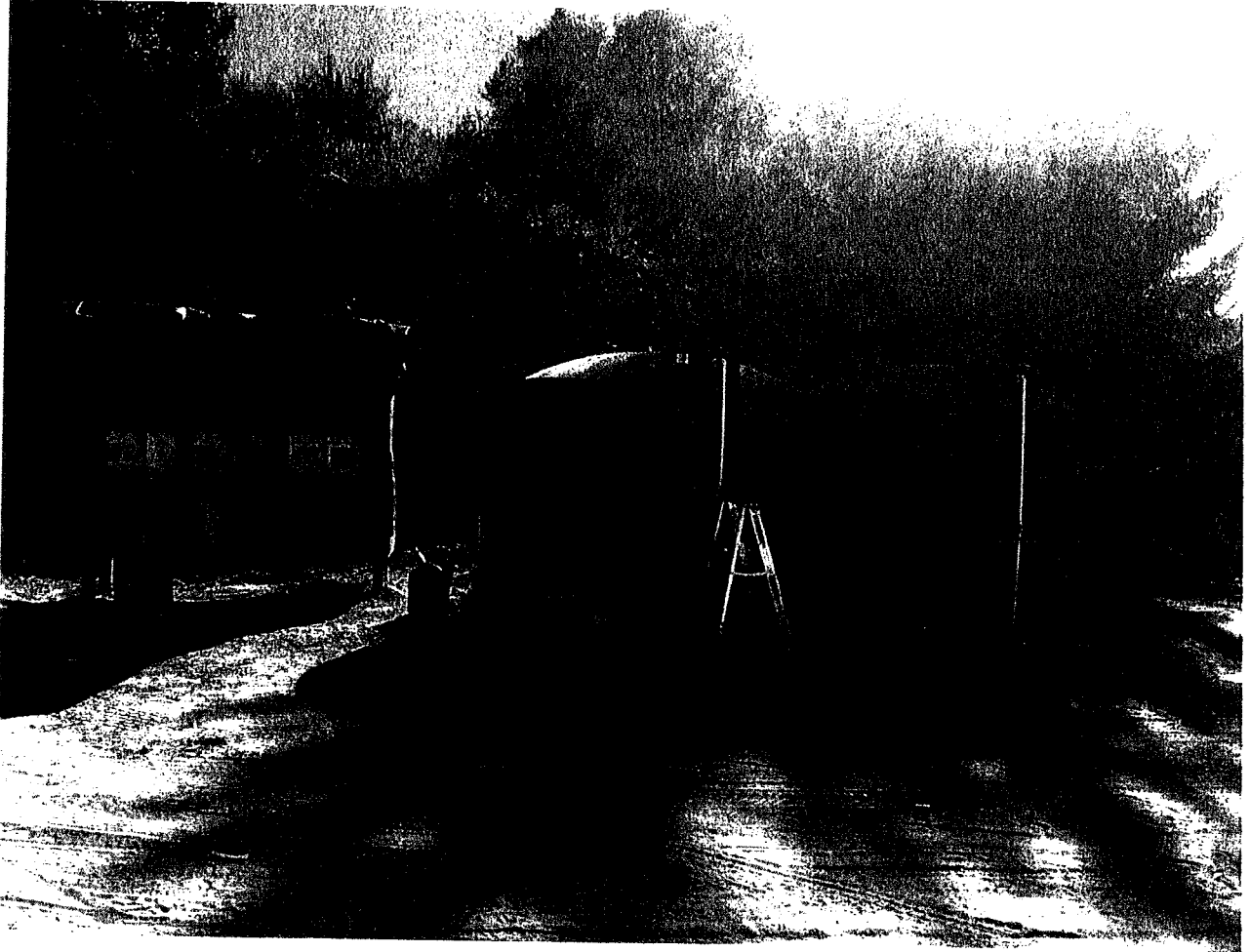

Picture 7: Southern-most well and two 2,500 gallon hard plastic tanks to right. Photo date 8-25-2016.

Addendum 10 – Pictures (Cont.)



Picture 8: Middle well located directly adjacent/west of the permanent rock road. Mixed light 30-foot by 60-foot greenhouses in distance. Photo date 8-25-2016.

Addendum 10 – Pictures (Cont.)



Picture 9: Northwestern-most well. Photo date 8-25-2016.

Addendum 10 – Pictures (Cont.)



Picture 10: 50,000 gallon pioneer tank. Photo date 8-25-2016.

Addendum 10 – Pictures (Cont.)

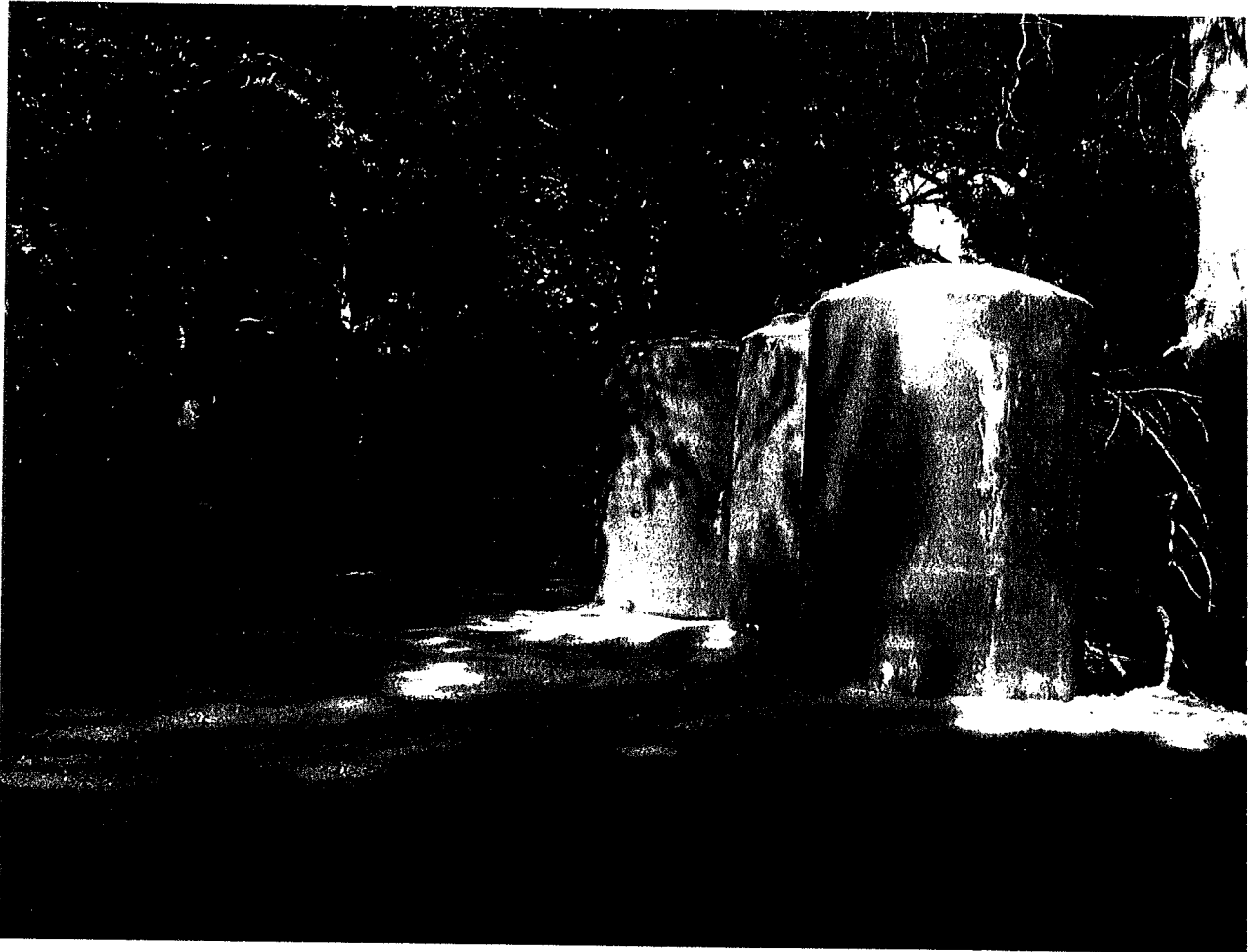

Picture 11: Tank farm located north of 50,000 gallon pioneer tank consisting of five 5,000-gallon hard plastic tanks. Photo date 8-25-2016.

Addendum 10 – Pictures (Cont.)

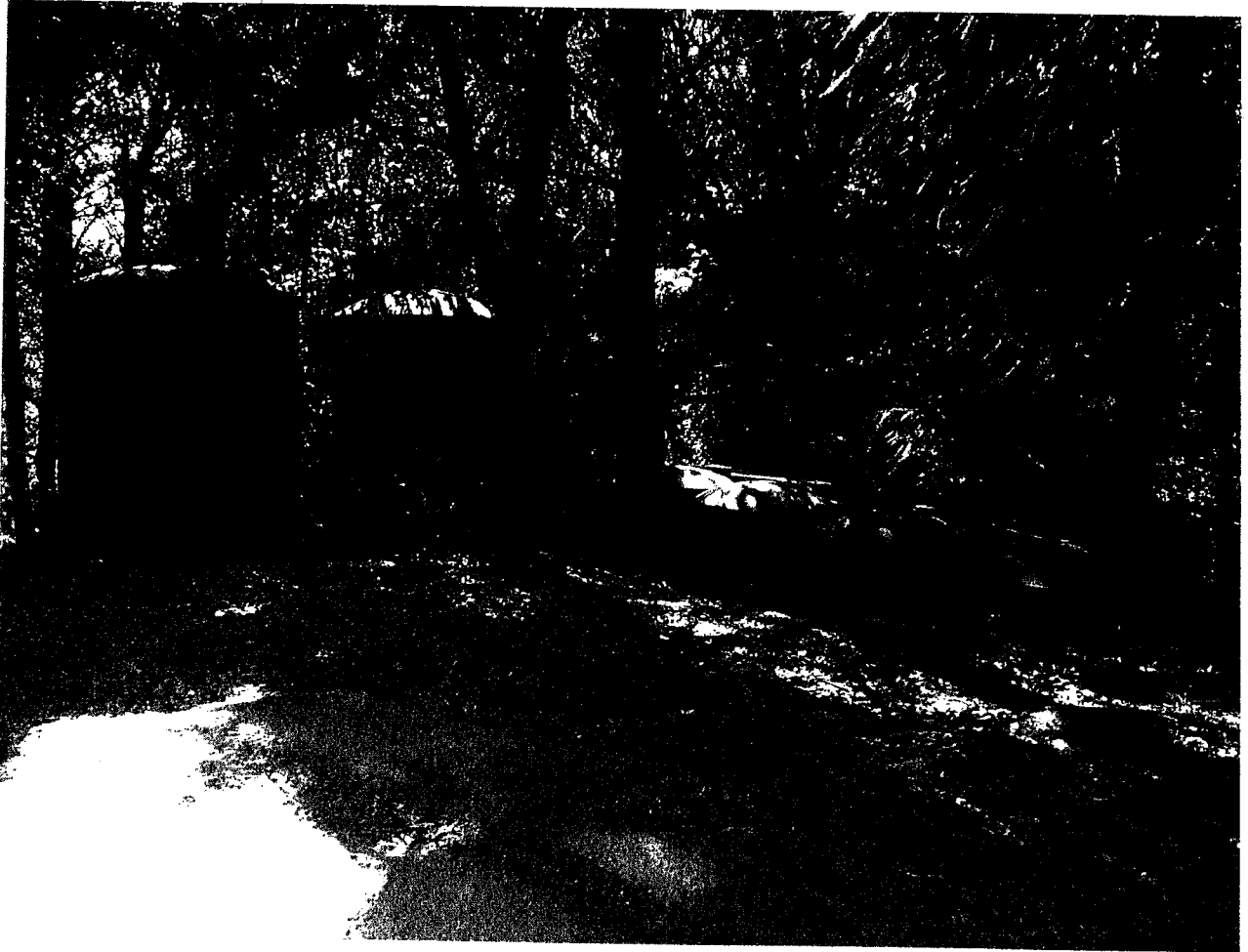

Picture 12: Tank farm located south of 50,000 gallon pioneer tank consisting of two 5,000-gallon, two 3,000-gallon, and two 2,500-gallon hard plastic tanks. Photo date 8-25-2016.

Addendum 10 – Pictures (Cont.)



Picture 13: Tank farm located approximately 150-feet south of POD consisting of five 5,000-gallon hard plastic tanks. Photo date 8-25-2016.

Addendum 10 – Pictures (Cont.)

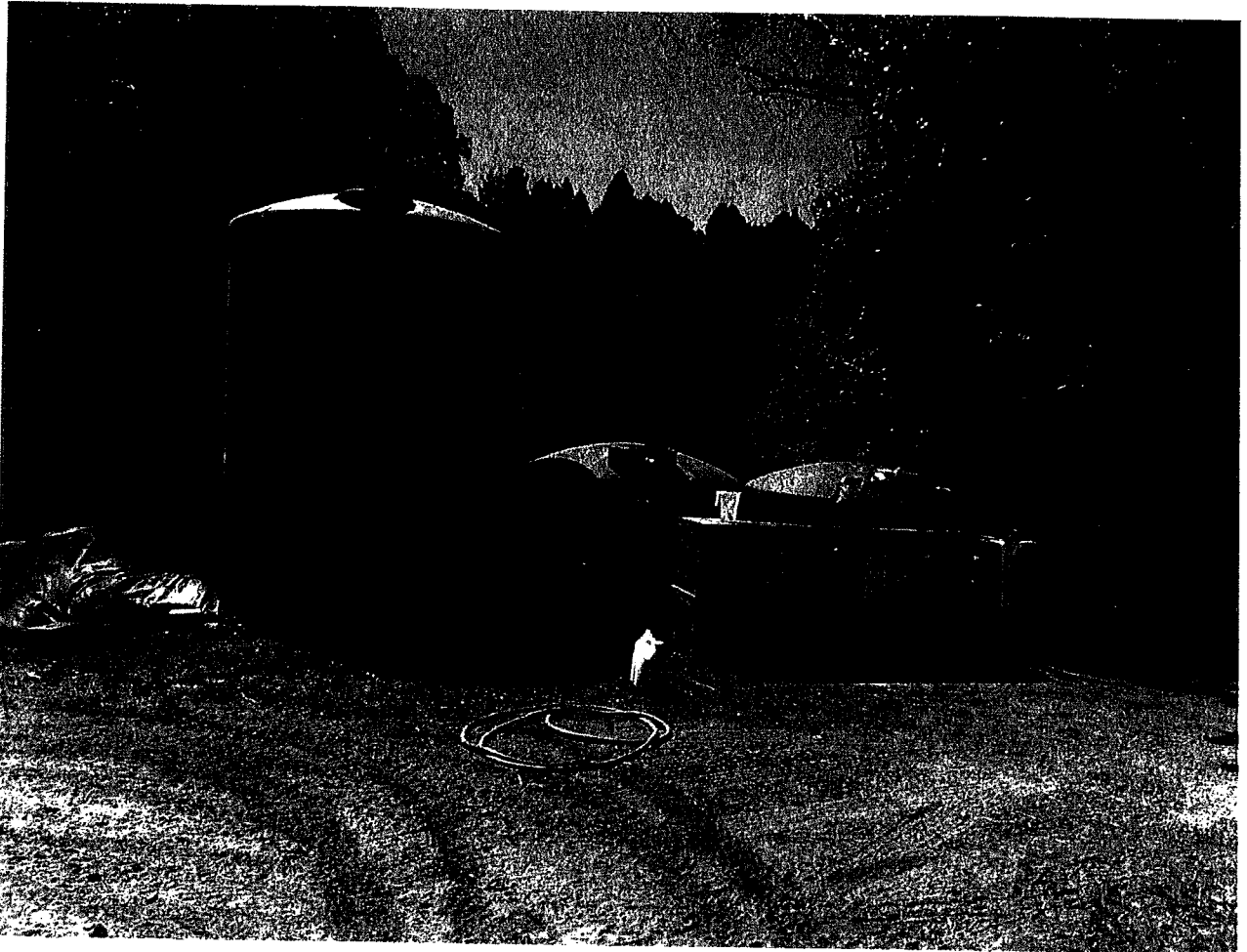

Picture 14: Tank farm located approximately 500-feet south of POD consisting of one 5,000-gallon and two 1,550- gallon hard plastic tanks. Photo date 8-25-2016.

Addendum 10 – Pictures (Cont.)



Picture 15: Upper cultivation site located in the southeastern corner of the property. Photo date 8-25-2016.

Addendum 10 – Pictures (Cont.)

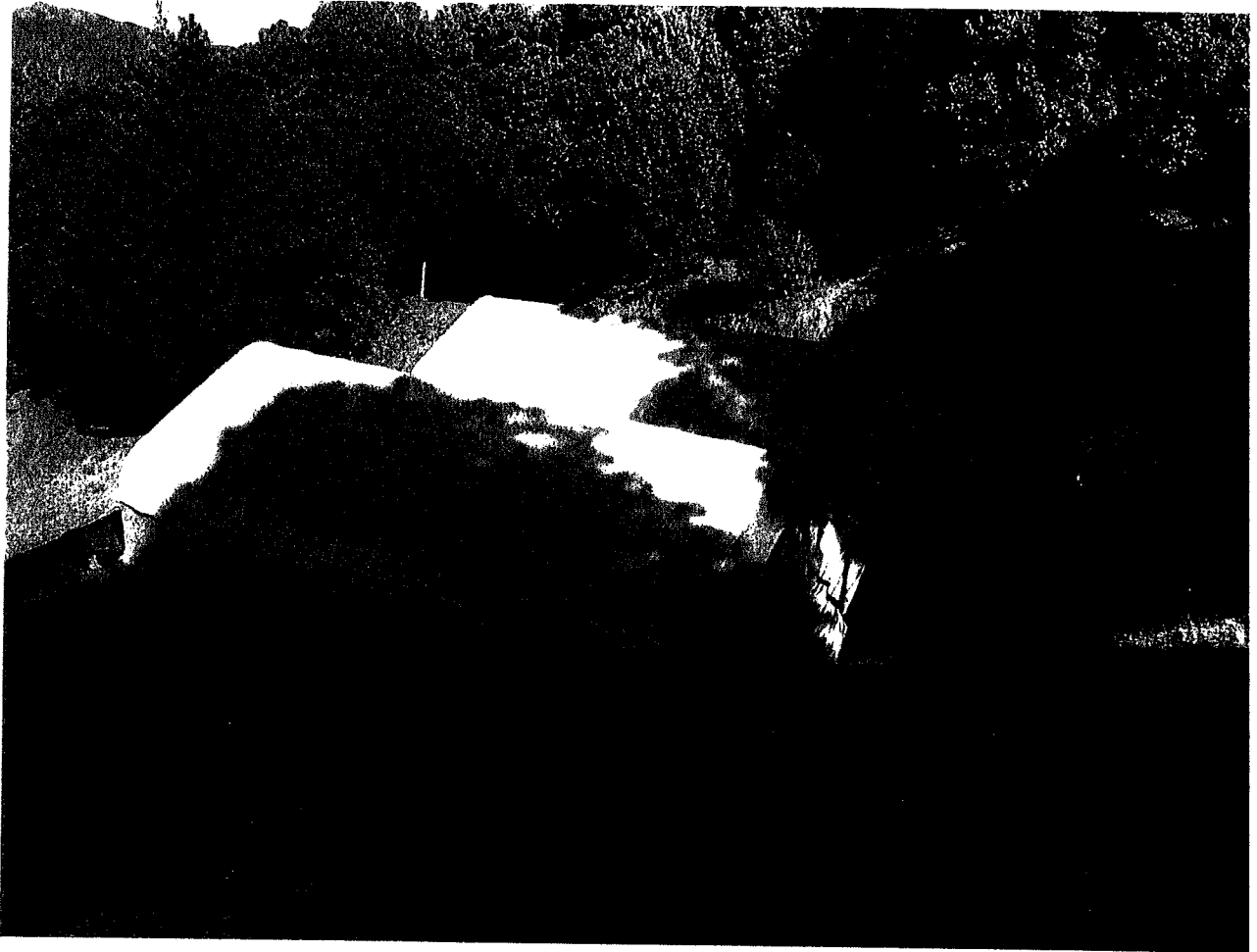

Picture 16: Two 30-foot by 60-foot mixed light greenhouses. Photo date 8-25-2016.

Addendum 10 – Pictures (Cont.)

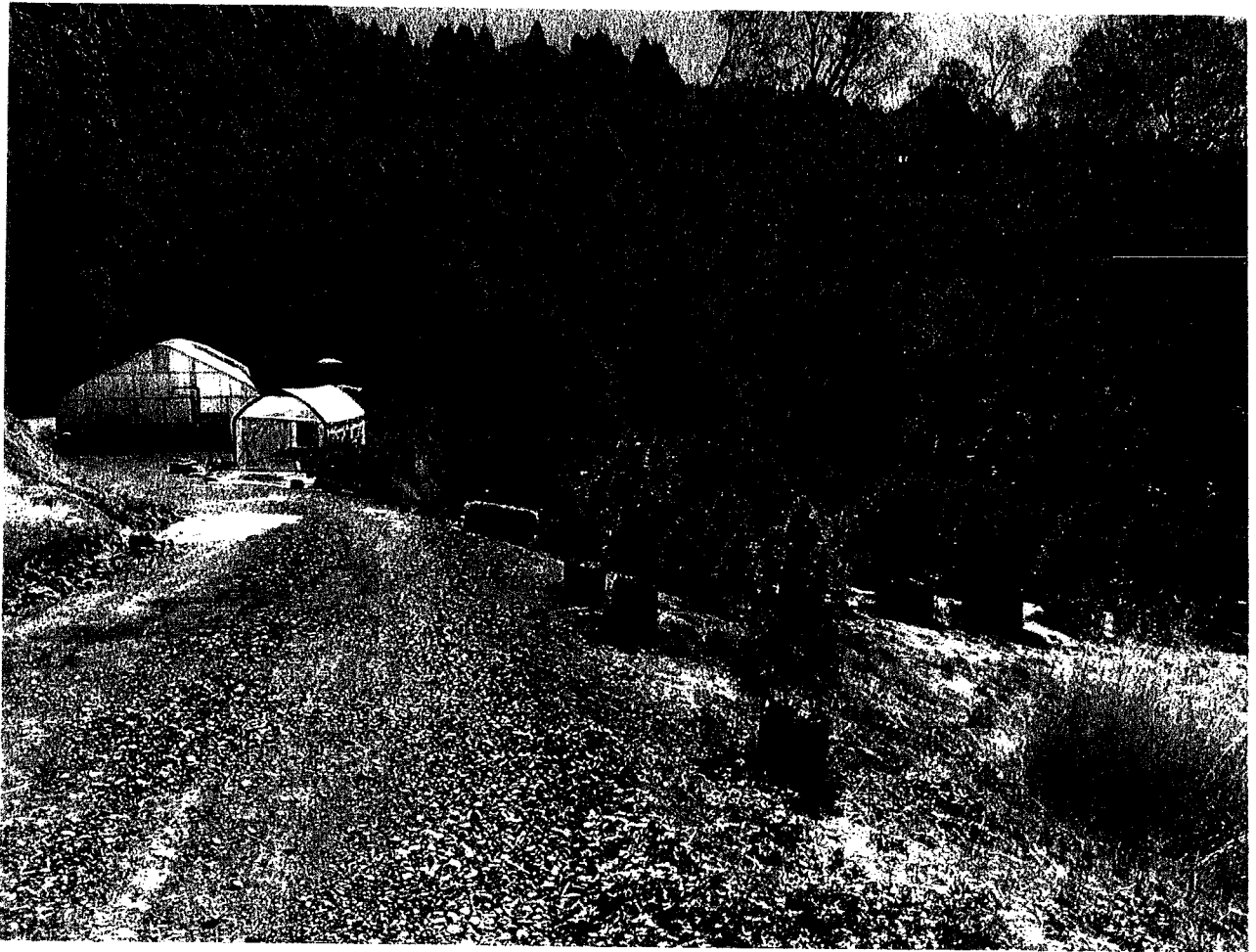

Picture 17: 30-foot by 90-foot mixed light greenhouse located at bottom of the property. Photo date 8-25-2016

Addendum 10 – Pictures (Cont.)

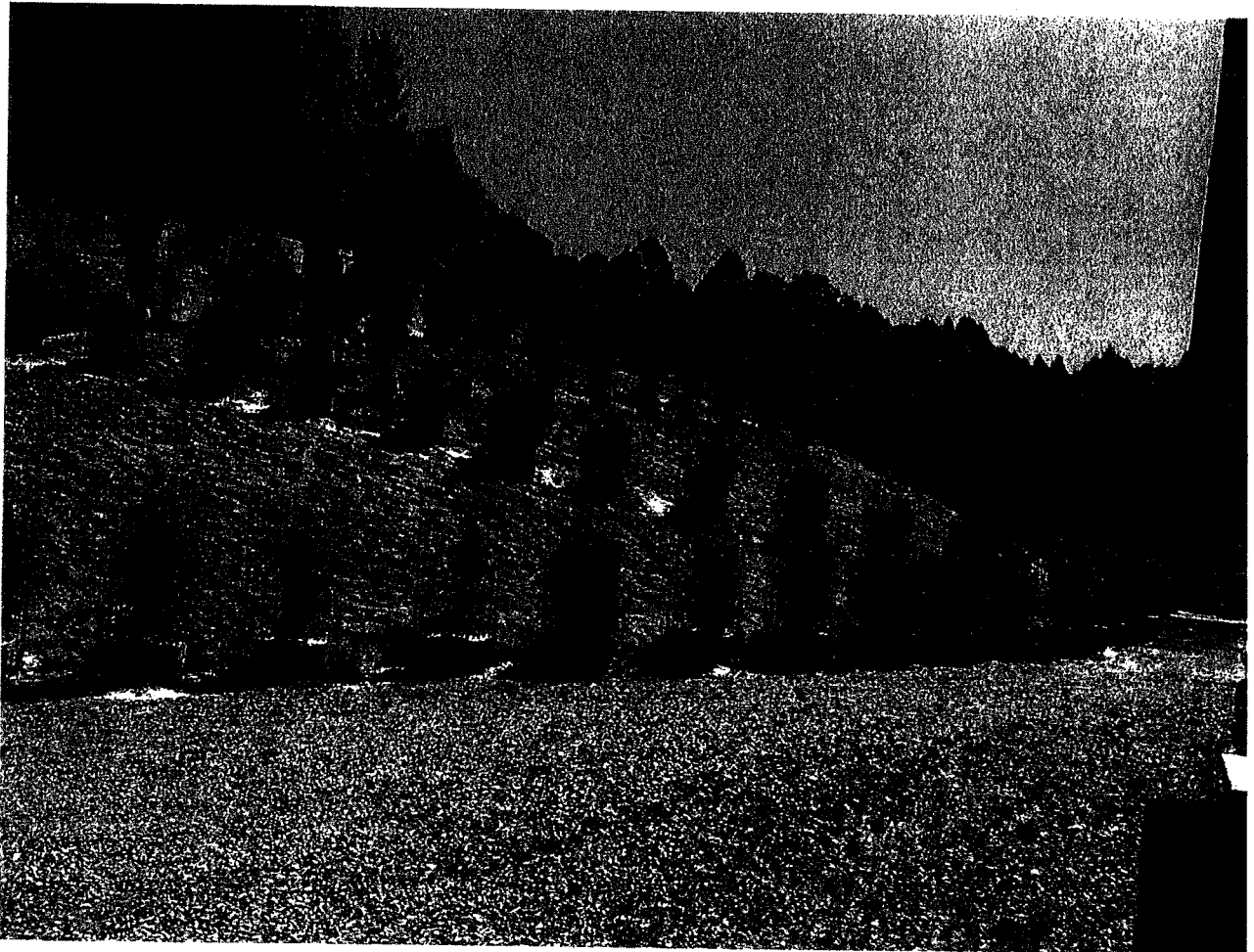

Picture 18: Cultivation located directly upslope of the residence. Photo date 8-25-2016

Addendum 10 – Pictures (Cont.)

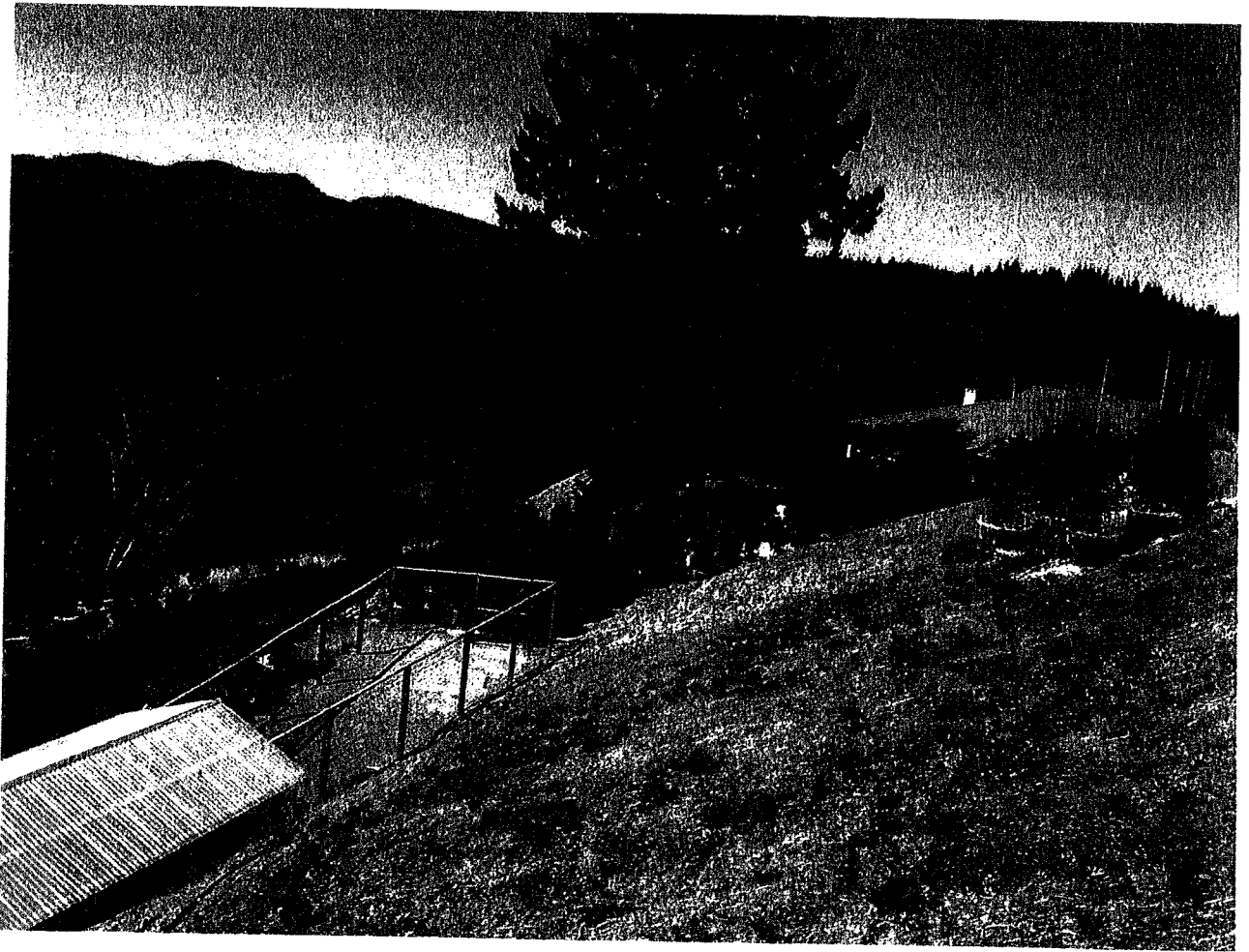

Picture 19: Hillside cultivation area located east-southeast of house. Chicken coop in left hand corner and house in distance to the right. Photo date 8-25-2016.

Addendum 10 – Pictures (Cont.)

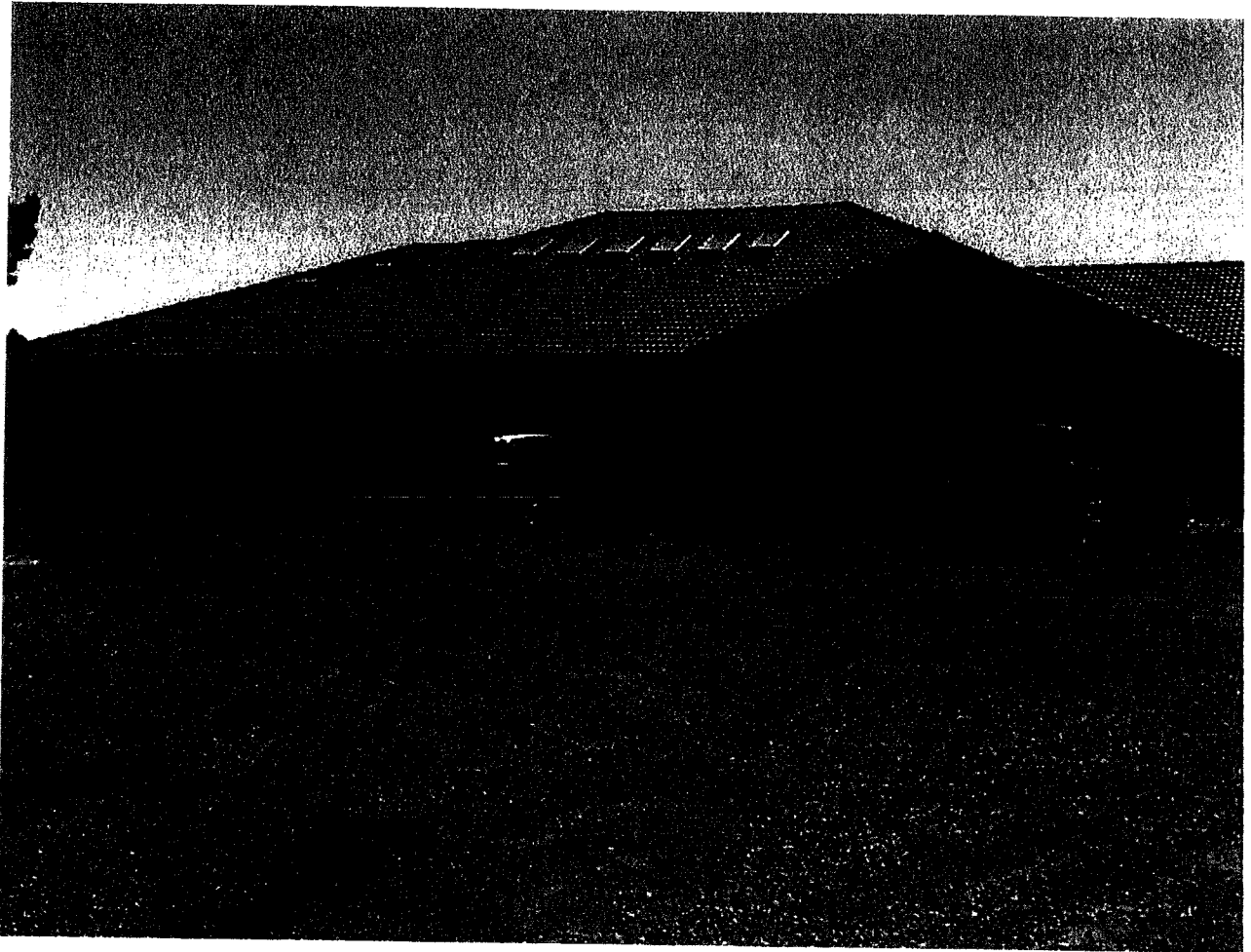

Picture 20: Landowner's residence. Photo date 8-25-2016.

ADDITIONAL INFORMATION

ADDITIONAL INFORMATION

NOTIFICATION OF LAKE OR STREAMBED ALTERATION

Applicant Name: THOMAS HARWOOD

Project Name: APN 220-081-016

ATTACHMENT C

Water Diversion Questionnaire

I. DIVERSION OR OBSTRUCTION

Please provide the additional information below *if* the project is directly related to any diversion, obstruction, extraction, or impoundment of the natural flow of a river, stream, or lake. If you have a current or expired Lake or Streambed Alteration Agreement (Agreement) for some activity related to your project, provide the Agreement number in your project description below.

- A. Attach plans of any diversion or water storage structure or facility that will be constructed or if no structures or facilities will be constructed, photographs of the project site, including any existing facilities or structures.
- B. Please complete the water use table below. For diversion rate, use gallons per day (gpd) if rate is less than 0.025 cubic foot per second (cfs) (approximately 16,000 gallons per day).

SEASON OF DIVERSION		PURPOSE OF USE	DIVERSION RATE (cfs or gpm)	AMOUNT USED (acre feet)	
BEGINNING DATE (Mo. & Day)	ENDING DATE (Mo. & Day)			FROM STORAGE	BY DIVERSION
January 1	December 31	DWS	1-4 gpm		73k gal

- C. Attach a topographic map that is labeled to show the following:
 - 1. Source of the water
 - 2. Points of diversion
 - 3. Areas of use
 - 4. Storage areas
- D. Specify the maximum instantaneous rate of withdrawal (using proposed equipment) in cubic feet per second (cfs) or gallons per minute (gpm): 4 gallons per minute

NOTIFICATION OF LAKE OR STREAMBED ALTERATION
ATTACHMENT C

- E. Check each box below that applies to the project water rights and attach supporting documents.
- Riparian. *Attach the most recent statement of riparian rights filed with the State Water Resources Control Board (SWRCB).*
 - Diversion for immediate use
 - Diversion to storage (for less than 30 days)

 - Appropriative
 - Pre-1914
 - Post-1914. *Attach a copy of the applicant's water right application, permit, or license filed with or issued by the SWRCB.*
 - Diversion for immediate use. *Attach a copy of the applicant's water right application, permit, or license filed with or issued by the SWRCB.*
 - Diversion to storage. *Attach a copy of the applicant's water right application, permit, or license filed with or issued by the SWRCB.*
 - Small domestic or livestock stockpond use. *Attach a copy of the applicant's registration of water use form filed with the SWRCB. (See Water Code section 1228 et seq.)*
 - Purchased or contracted water. *Attach a copy of the applicant's contract or letter from the applicant's water provider.*
 - Other. *Describe below or attach separate page.*

- F. Approximate lowest level of flow in the river, stream, or lake at the point of diversion during the proposed season of diversion in gpm or cfs: Unknown but no more than 10% of flow shall be diverted.
- G. Other information. After the Department reviews the project description, and based on the project's location and potential impacts to fish and wildlife resources, the Department will determine if additional information is needed to complete the notification. Such information could include more site-specific information to ensure that the terms and conditions in the Lake or Streambed Alteration Agreement issued to the applicant will be adequate to protect the fish and wildlife resources the diversion or obstruction could adversely affect. Site-specific information could include specific studies based on the season of diversion, the location of the diversion relative to other diversions in the watershed, the method of diversion, and the quantity of water to be diverted, such as the following:

1. *Water Availability Analysis* to determine if the water can be diverted without causing substantial adverse effects on downstream fish and wildlife resources. Water availability analyses are based on a comparison of flows without any diversions (unimpaired flows) and flows available when all known diversions are "subtracted" (impaired flows). The protocol for water availability analyses is available on request.
2. *Instream Flow Study* to determine the minimum bypass flows needed and maximum rates of withdrawal possible to provide adequate depths and velocities to protect habitat for all life stages of aquatic resources. The study plan, which must be prepared by a qualified fisheries biologist and approved by the Department, will determine the effects of the proposed diversion on flow depth and velocity.
3. *Water Quality Study* to assess the effects of the proposed water diversion or impoundment on water temperature and water quality at and downstream from the point of diversion.

II. PERMANENT OR TEMPORARY RESERVOIR

Please provide the information below *if* the project includes the construction of a reservoir, whether permanent or temporary, and/or the filling of a reservoir by diverting or obstructing the flow of a river, stream, or lake.

- A. Proposed use of the stored water: _____
- B. Construction plans for the reservoir and dam. (*Attach plans*)
- C. A complete description of the reservoir and dam, including the methods and materials that will be used to construct the reservoir and dam and the following dimensions certified by a licensed professional: the width, length, depth, and total surface area of the reservoir pool; the volume of water in acre-feet that will be stored in the reservoir; and the height and length of the dam.
- D. The amount of riparian land that will be inundated (i.e., upstream from the dam): _____
- E. Where vehicles will enter and exit the project site during construction and for maintenance purposes after construction. (*Attach map*)
- F. The maximum distance of the disturbance that will occur upstream and downstream during construction: _____
- G. The methods that will be employed to ensure that the flow is maintained below the dam at all times when water is being diverted into the reservoir. _____

- H. Specify the time period when the area below the dam becomes dry, if at all. _____

NOTIFICATION OF LAKE OR STREAMBED ALTERATION
ATTACHMENT C

I. The methods that will be employed to ensure that adult and juvenile fish will be able to pass over or around the dam. _____

J. If a fish ladder is necessary to enable adult and juvenile fish to pass over or around the dam, provide construction plans and an operation plan for the fish ladder. (*Enclose, if applicable*)

K. The methods that will be employed to monitor and maintain water quality (including temperature) within the reservoir. _____

III. TEMPORARY RESERVOIR

Please provide the information below *if* the project includes the construction of a temporary reservoir only within the stream zone.

A. Date of dam installation: _____

B. Date of dam removal: _____

C. Amount of time it will take to construct the dam: _____

D. Amount of time it will take to remove the dam: _____

E. Methods to ensure that the reservoir pool will be drained in a manner that does not strand or otherwise harm fish: _____



165 South Fortuna Boulevard, Fortuna, CA 95540
707-725-1897 • fax 707-725-0972
trc@timberlandresource.com

January 24, 2022

Lost Coast Elixirs, LLC
Thomas Harwood
PO Box 196
Redway CA, 95560

Re: APN 220-081-016
PLN-11247-CUP

The following is an evaluation of potential timberland conversion on cannabis cultivation sites and associated areas included in the Humboldt County Cannabis Application #11247. Please accept this letter as the RPF's written report required by Humboldt County Code, Ordinance No. 2559 (Commercial Medical Marijuana Land Use), Section 55.4.12.2.4 as cited below.

"Where existing or proposed operations occupy sites created through prior unauthorized conversion of timberland, if the landowner has not completed a civil or criminal process and/or entered into a negotiated settlement with CALFIRE, the applicant shall secure the services of a registered professional forester (RPF) to evaluate site conditions and conversion history for the property and provide a written report to the Planning Division containing the RPF's recommendation as to remedial actions necessary to bring the conversion area into compliance with provisions of the Forest Practices Act. The Planning Division shall circulate the report to CAL-FIRE for review and comment."

Timberland Resource Consultants (TRC) inspected and evaluated the cultivation sites and associated areas contained within the application on January 17, 2022. The RPF exercised due diligence in reviewing all sites and available resources to fully assess potential timberland conversion and consequential impacts. This report evaluates the cultivation sites and associated areas for timber operations only. The scope of this report does not include: all other land alteration (such as grading, construction, and other permit-regulated activities), all property features and sites unrelated to cultivation activities, or any proposed, planned, or absent cultivation-related project sites. All findings are summarized in the report below.

Project Location

APN: 220-081-016
Acreage: 40 acres
Legal Description: NW ¼ of SW ¼ of Section 21
Township 4 South, Range 2 East,
Humboldt Base & Meridian, Humboldt County
Located on USGS 7.5' Quadrangle: Briceland
Humboldt County Zoning: Unclassified
Site Address: 569 Eubanks Road, Whitethorn
Landowner/Timber Owner: Thomas & Christina Harwood

The project is located in Humboldt County, in the Whitethorn area, on the north side of Eubanks Road, Access to the property is approximately 1.1 miles on Eubanks Road from the intersection of Ettersburg Road to the gated road accessing the property.

Parcel Description & Timber Harvest History

Note: The property background has been summarized using personal accounts of the current landowner, digital orthographic quadrangle (DOQ) imagery, Humboldt County Web GIS, CAL FIRE Watershed Mapper v2, and Historic Aerials. To avoid speculation and maintain relevancy, the property background focuses mainly on the past 10-15 years.

The property is comprised of second growth tanoak & Douglas-fir, and grassland and brush in various stages of conifer/hardwood encroachment. Review of historic aerial imagery (<https://www.historicaerials.com>) from 1948 and 1968 shows no sign of large-scale clearcutting, however there is evidence that individual trees or clumps of old growth Douglas-fir visible on the 1948 imagery were harvested in the late 1950's/early 1960's. In addition, there is photographic evidence of logging roads skid roads and small log landings. There have been no commercial harvests on the property since the initial entry as recorded by Cal Fire (Watershed Mapper v2 http://egis.fire.ca.gov/watershed_mapper/). The property was transferred to the current owner in February 2009.

Project Description

Nine cultivation sites and associated areas were inspected during the field assessment within APN 220-081-016. The labeling of the sites is consistent with the Property Diagram dated January 13, 2022 (attached). The following table lists the inspected sites and their acreages; see detailed site descriptions below.

Cultivation Site/Associated Area	Total Acreage	Converted?	Converted Acreage
Site A = Light-Dep Zone 1	0.95	Yes	0.95
Site B = Mixed Light Zone 1	0.38	Yes	0.38
Site C = 2-Story Building Site	0.06	Yes	0.06
Site D = Materials and Storage Site	0.12	Yes	0.12
Site E = Outdoor Area 1	0.39	Yes	0.09
Site F = Outdoor Area 2	0.15	Yes	0.15
Site G = Outdoor Area 3	0.09	Yes	0.09
Site H = Immature Plant Area	0.04	Yes	0.04
Site I = Mixed Light Zone 2	0.44	Yes	0.06
Total:	2.62		1.94

Light-Dep Zone 1

Review of NAIP, Google, and LandVision imagery reveals that Light-Dep Zone 1 was developed between 9-18-2015 (LandVision) and 2016 (NAIP). The cultivation activities observed at Light-Dep Zone 1 impedes the use of this space for current timber growth and future harvesting; in this way, the landowner has effectively converted this area from timber production to cannabis cultivation.

Mixed Light Zone 1

Review of NAIP, Google, and LandVision imagery reveals that Mixed Light Zone 1 was developed between 7-2006 and 6-2009 (Google). The cultivation activities observed at Mixed Light Zone 1 impedes the use of this space for current timber growth and future harvesting; in this way, the landowner has effectively converted this area from timber production to cannabis cultivation.

2-Story Building Site

Review of NAIP, Google, and LandVision imagery reveals that the 2-Story Building Site was developed between 2014 (NAIP) and 9-18-2015 (LandVision). The cultivation activities observed at the 2-Story Building Site impedes the use of this space for current timber growth and future harvesting; in this way, the landowner has effectively converted this area from timber production to cannabis cultivation.

Project Description (Cont.)

Materials and Storage Site

Review of NAIP, Google, and LandVision imagery reveals that the Materials and Storage Site was developed between 8-2012 and 5-2014 (Google). The cultivation activities observed at the Materials and Storage Site impedes the use of this space for current timber growth and future harvesting; in this way, the landowner has effectively converted this area from timber production to cannabis cultivation.

Outdoor Area 1

Review of NAIP, Google, and LandVision imagery reveals that Outdoor Area 1 was initially developed to what appears to be a grape vineyard between 1998 and 2005 (NAIP). This development occurred in natural grassland. The site was slightly expanded between 2005 and 2009 (NAIP), which involved removal of trees, to its present size and configuration. The cultivation activities observed at Outdoor Area 1 impedes the use of a small portion of this space for current timber growth and future harvesting; in this way, the landowner has effectively converted portions of this area from timber production to cannabis cultivation.

Outdoor Area 2

Review of NAIP, Google, and LandVision imagery reveals that Outdoor Area 2 was developed between 1998 and 2005 (NAIP). The cultivation activities observed at Outdoor Area 2 impedes the use of this space for current timber growth and future harvesting; in this way, the landowner has effectively converted this area from timber production to cannabis cultivation.

Outdoor Area 3

Review of NAIP, Google, and LandVision imagery reveals that Outdoor Area 3 was developed between 2012 and 2014 (NAIP). The cultivation activities observed at Outdoor Area 3 impedes the use of this space for current timber growth and future harvesting; in this way, the landowner has effectively converted this area from timber production to cannabis cultivation.

Immature Plant Area

Review of NAIP, Google, and LandVision imagery reveals that the Immature Plant Area was developed between 2005 and 2006 (Google). The cultivation activities observed at the Immature Plant Area impedes the use of this space for current timber growth and future harvesting; in this way, the landowner has effectively converted this area from timber production to cannabis cultivation.

Mixed Light Zone 2

Review of NAIP, Google, and LandVision imagery reveals that Mixed Light Zone 2 was an old log landing or pre-existing developed site visible on 1993 and 1996 Google imagery. Expansion involving timberland conversion occurred between 7-2006 and 6-2009 (Google). Several trees were harvested along the southeastern periphery of the site, without timberland conversion, between 2016 and 2018 (NAIP). The cultivation activities observed at Mixed Light Zone 2 impedes the use of a small portion of this space for current timber growth and future harvesting; in this way, the landowner has effectively converted portions of this area from timber production to cannabis cultivation.

Timberland Conversion Summary

TRC observed 1.94 acres of timberland conversion for cultivation-related purposes. This total does not exceed the three-acre conversion exemption maximum.

Limitations and Considerations for Timberland Conversion Activities

Watercourses and Water Resources

14CCR 1104.1(a)(2)(F): "No timber operations are allowed within a watercourse and lake protection zone unless specifically approved by local permit (e.g., county, city)."

No conversion areas exist within a Watercourse and Lake Protection Zone (WLPZ). Further, no cultivation sites are located within a riparian buffer per State Water Resources Control Board Order WQ 2019-0023-DWQ, or a Humboldt County Stream Management Area based upon the RPF's physical inspection of the surrounding areas.

Slash, Woody Debris, and Refuse Treatment

14 CCR 914.5(b): "Non-biodegradable refuse, litter, trash, and debris resulting from timber operations, and other activity in connection with the operations shall be disposed of concurrently with the conduct of timber operations."

14CCR 1104.1(a)(2)(D) -- Treatment of Slash and Woody Debris

- 1) Unless otherwise required, slash greater than one inch in diameter and greater than two feet long, and woody debris, except pine, shall receive full treatment no later than April 1 of the year following its creation, or within one year from the date of acceptance of the conversion exemption by the Director, whichever comes first.
- 2) All pine slash three inches and greater in diameter and longer than four feet must receive initial treatment if it is still on the parcel, within 7 days of its creation.
- 3) All pine woody debris longer than four feet must receive an initial treatment prior to full treatment.
- 4) Initial treatment shall include limbing woody debris and cutting slash and woody debris into lengths of less than four feet, and leaving the pieces exposed to solar radiation to aid in rapid drying.
- 5) Full treatment of all pine slash and woody debris must be completed by March 1 of the year following its creation, or within one year from the date of acceptance of the conversion exemption by the Director, whichever comes first.
- 6) Full slash and woody debris treatment may include any of the following:
 - a) Burying;
 - b) Chipping and spreading;
 - c) Piling and burning; or
 - d) Removing slash and woody debris from the site for treatment in compliance with (a)-(b). Slash and woody debris may not be burned by open outdoor fires except under permit from the appropriate fire protection agency, if required, the local air pollution control district or air quality management district. The burning must occur on the property where the slash and woody debris originated.
- 7) Slash and woody debris, except for pine, which is cut up for firewood shall be cut to lengths 24 inches or less and set aside for drying by April 1 of the year following its creation. Pine slash and woody debris which is cut up for firewood shall be cut to lengths 24 inches or less and set aside for drying within seven days of its creation.
- 8) Any treatment which involves burning of slash or woody debris shall comply with all state and local fire and air quality rules.

The RPF observed no slash, logs, and/or woody debris at either site, which would require treatment per the Forest Practice Rules.

Biological Resources and Forest Stand Health

14 CCR 1104.1 (2)(H): "No sites of rare, threatened or endangered plants or animals shall be disturbed, threatened or damaged and no timber operations shall occur within the buffer zone of a sensitive species as defined in 14 CCR 895.1"

The query of the CNDDDB Database on January 17, 2022 revealed one observation of sensitive, rare, threatened, or endangered species or species of special concern within a 0.7-mile radius biological assessment area (BAA) surrounding the property. A red-bellied newt is documented within Eubank Creek a distance of approximately ¼ mile southwest from the property. See attached CNDDDB Map. The red-bellied newt is a non-listed State species of special concern. The status of this species would not have required

Limitations and Considerations for Timberland Conversion Activities (Cont.)

consultation with CDFW in association with a Cal Fire Conversion Exemption. The converted areas are not located in or near suitable habitat for this species. No sensitive, rare, threatened, or endangered species or species of special concern were observed during the TRC field assessment of the project area, though potential habitat exists on the property.

The query of the CNDDDB NSO Database revealed no known Northern Spotted Owl (NSO) Activity Centers within a 0.7-mile radius biological assessment area (BAA) surrounding the conversion sites.

The conversion areas did not include late successional stands, late seral stage forests, or old growth trees. The conversion area did not include any trees that existed before 1800 A.D. and are greater than sixty (60) inches in diameter at stump height for Sierra or Coastal Redwoods, and forty-eight (48) inches in diameter at stump height for all other tree species.

Sudden Oak Death

No major forest health issues were observed during the field assessment. The property is located within Humboldt County, a Zone of Infestation (ZOI) for Sudden Oak Death (SOD) and the RPF observed symptoms, signs, and evidence of oak mortality throughout the subject property, including infected tanoak trees located adjacent to the Tank Farm and Outdoor Area 2 as shown on the attached photographs.

Preliminary research has shown that trees infected or killed by SOD are prone to rapid decay and unpredictable failure. The RPF's professional experience and opinion is that infected trees will eventually die and topple over and their removal is recommended when located within striking distance of improvements to minimize hazard. Proper disposal of infested SOD material contributes toward limiting pathogen spread. Removal of SOD debris from the property is not recommended. Whenever possible, leave SOD tree debris on site in a safe area where woody debris will not become dislodged, contaminate uninfected hosts, or constitute a fire hazard. When infected oaks are cut down and left on site, chip the branches and cut and split the wood. To prevent pathogen spread via muddy boots or equipment, avoid chipping in wet weather. Stack woodpiles in sunny locations to promote rapid drying. Do not leave firewood and chips in an area where they might be transported to another location. Leaving infected trees intact on site may benefit wildlife. If chipping is not possible, reduce fire hazard by lopping and scattering branches so they lay close to the ground at least 30 feet away from any structure, driveway, roadside, or propane tank (consult your local fire department). See attachment *A Homeowners Guide to Sudden Oak Death*.

Cultural Resources

14 CCR 1104.1 (2)(I): "No timber operations are allowed on significant historical or archeological sites."

No archeological sites were observed during the TRC field assessment. The RPF conducted pre-field research for the project's geographic location and closely surveyed the converted sites and surrounding undisturbed areas for presence or evidence of prehistoric or historic sites. The archaeological survey was conducted by Chris Carroll, a certified archaeological surveyor with current CALFIRE Archeological Training (Archeological Training Course #575). The survey consisted of examining boot scrapes, rodent disturbances, natural and manmade areas of exposed soils, and road and cultivation site surfaces. Per 14 CCR 1104.2(2)(I), all required Native American tribes and organizations have been notified of the project location and are encouraged to respond with any information regarding archaeological sites, cultural sites, and/or tribal cultural resources within or adjacent to the project area.

14CCR 923.4 Construction and Reconstruction of Logging Roads and Landings

While it's recognized that cannabis cultivation sites are not log landings; initial development and construction and subsequent maintenance of the graded flats should (at a minimum) meet or exceed similar requirements stated in the Forest Practice Rules for log landings. Compliance with Humboldt County's grading & SMA ordinance, State Water Resources Control Board Order WQ 2019-0001-DWQ, and other regulations will require even higher standards. Therefore, the RPF closely evaluated all cultivation sites for such compliance. The RPF has concluded that the performance standards of 923.4(a-s) have been met.

Limitations and Considerations for Timberland Conversion Activities (Cont.)

14CCR 923.5 Erosion Control for Logging Roads and Landings

All of the roads on the property accessing cultivation sites and associated cannabis-related improvements are rocky permanent roads, including a stretch of paved road. All of the roads accessing the cultivation sites have been significantly upgraded since TRC's original assessment in 2016 in association with the preparation of the Water Resource Protection Plan. The landowner has implemented numerous mitigation measures required in the Watercourse Resource Protection Plan and CDFW 1600 Agreement (1600-2016-0436-R1) to address road drainage and water quality. All access roads are in compliance with 14CCR 923.5.

14CCR 923.9 Watercourse Crossings

A property-wide CDFW 1600 Agreement (1600-2016-0436-R1) covers cultivation activities on the property. All existing stream crossings have been assessed by TRC and are functional and in compliance with 14CCR 923.9(f), which requires that all permanent watercourse crossings accommodate the estimated 100-year flood flow, including debris and sediment loads.

Recommendations

In summary, a total of 1.94 acres of unauthorized timberland conversion has occurred within APN 220-081-016. This total does not exceed the three-acre conversion exemption maximum. The conversion activities conducted on the property comply with the California Forest Practice Act and the California Forest Practice Rules.

The RPF recommends the following:

1. Remove dead, dying, and diseased tanoak trees infested with Sudden Oak Death in areas as shown on the attached photographs. Treat material per the attachment titled *A Homeowners Guide to Sudden Oak Death*.

Sincerely,



Chris Carroll, RPF #2628
Timberland Resource Consultants

Photos

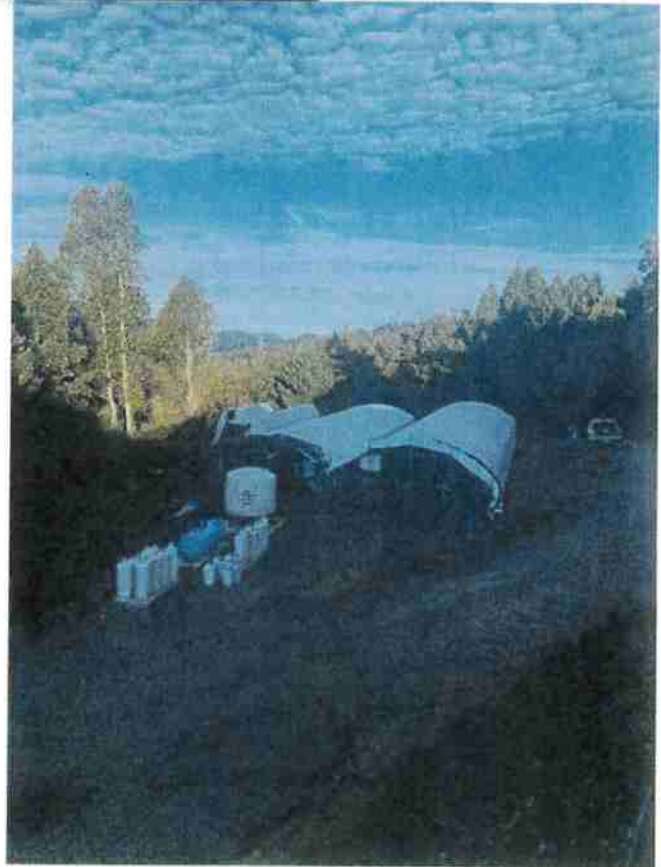
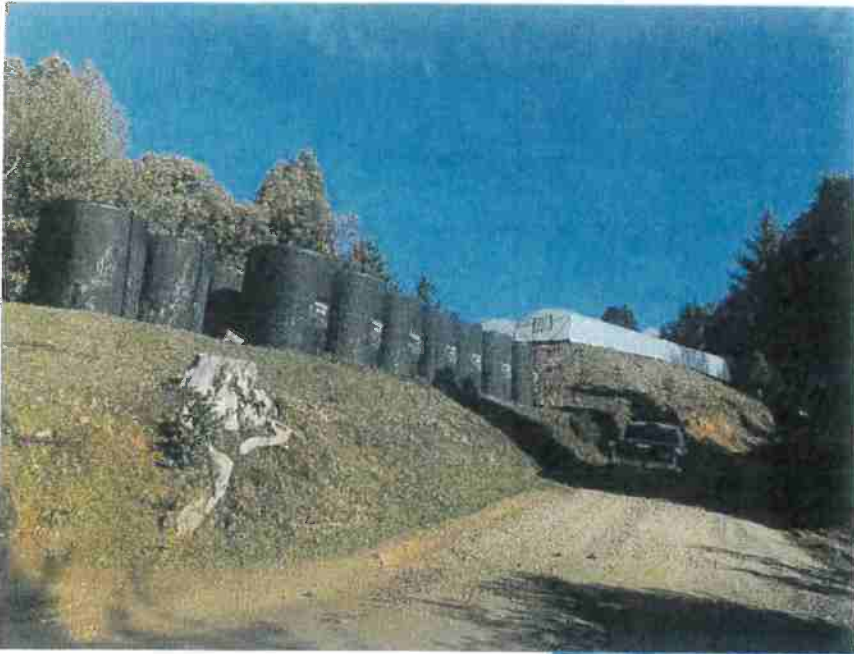

Photo 1: Site A. Photo date 1-17-2022

Photos

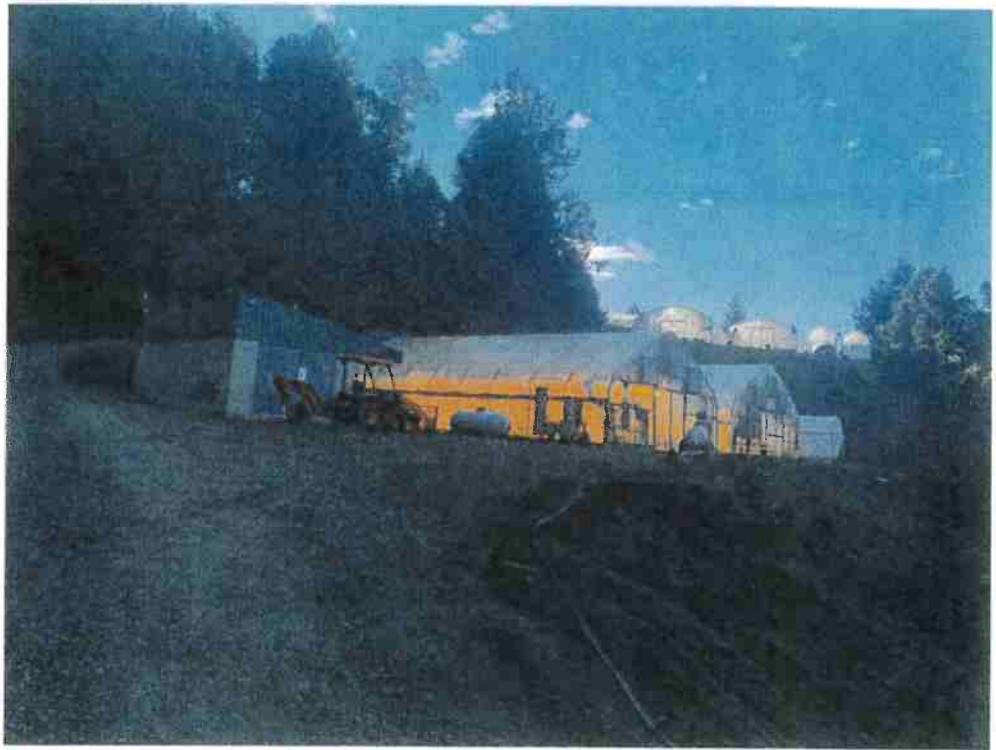

Photo 2: Site B. Photo date 1-17-2022

Photos



Photo 3: Site B center and Site A distant left. Note rocky V-ditch constructed to accommodate storm-water runoff from the graded flat. Photo date 1-17-2022.

Photos



Photo 4: Site C (upper) and Site D (lower). Photo date 1-17-2022.

Photos



Photo 5: Site E. Photo date 1-17-2022.

Photos

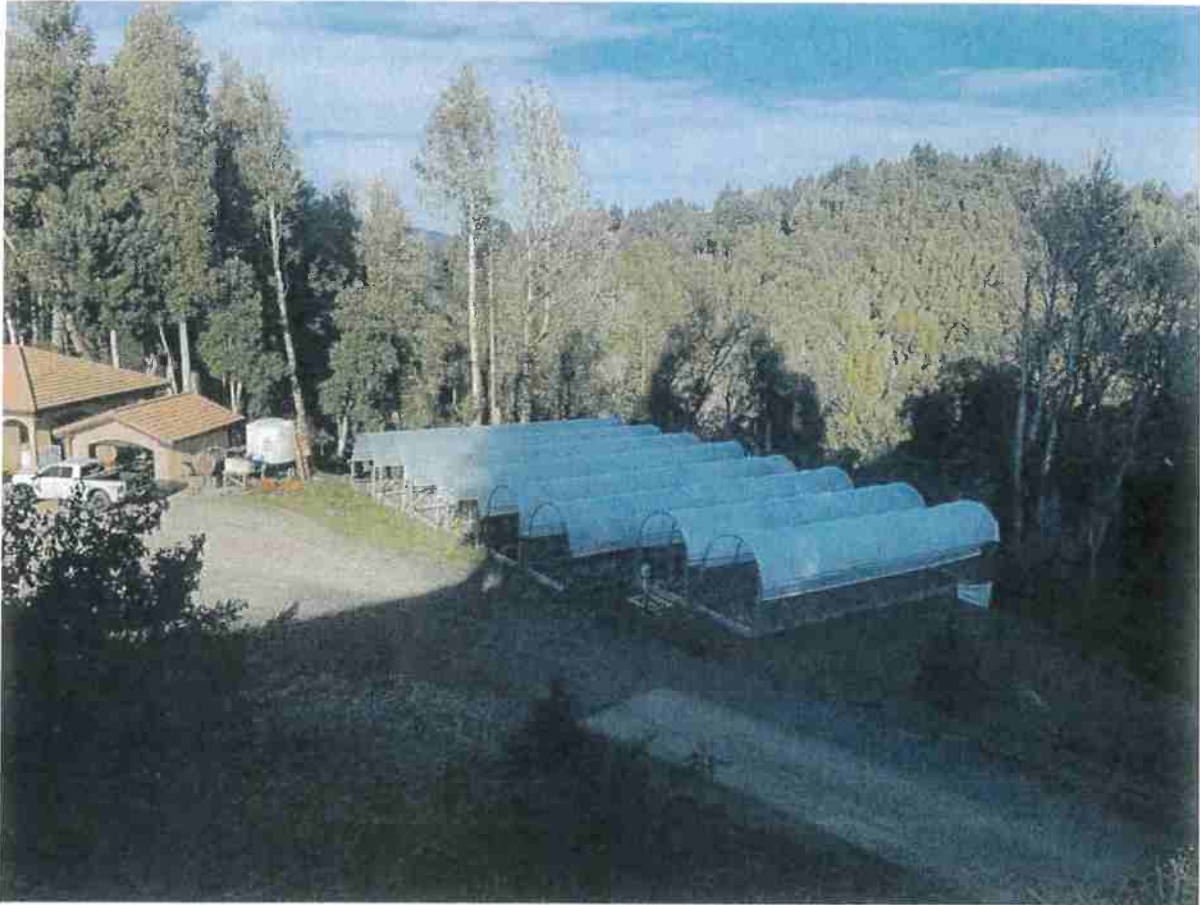

Photo 6: Site F. Note dying tanoak trees infected with SOD behind greenhouses. Photo date 1-17-2022.

Photos



Photo 7: Site G (left) and Site H (right). Photo date 1-17-2022.

Photos



Photo 8: Site I. Photo date 1-17-2022.

Photos

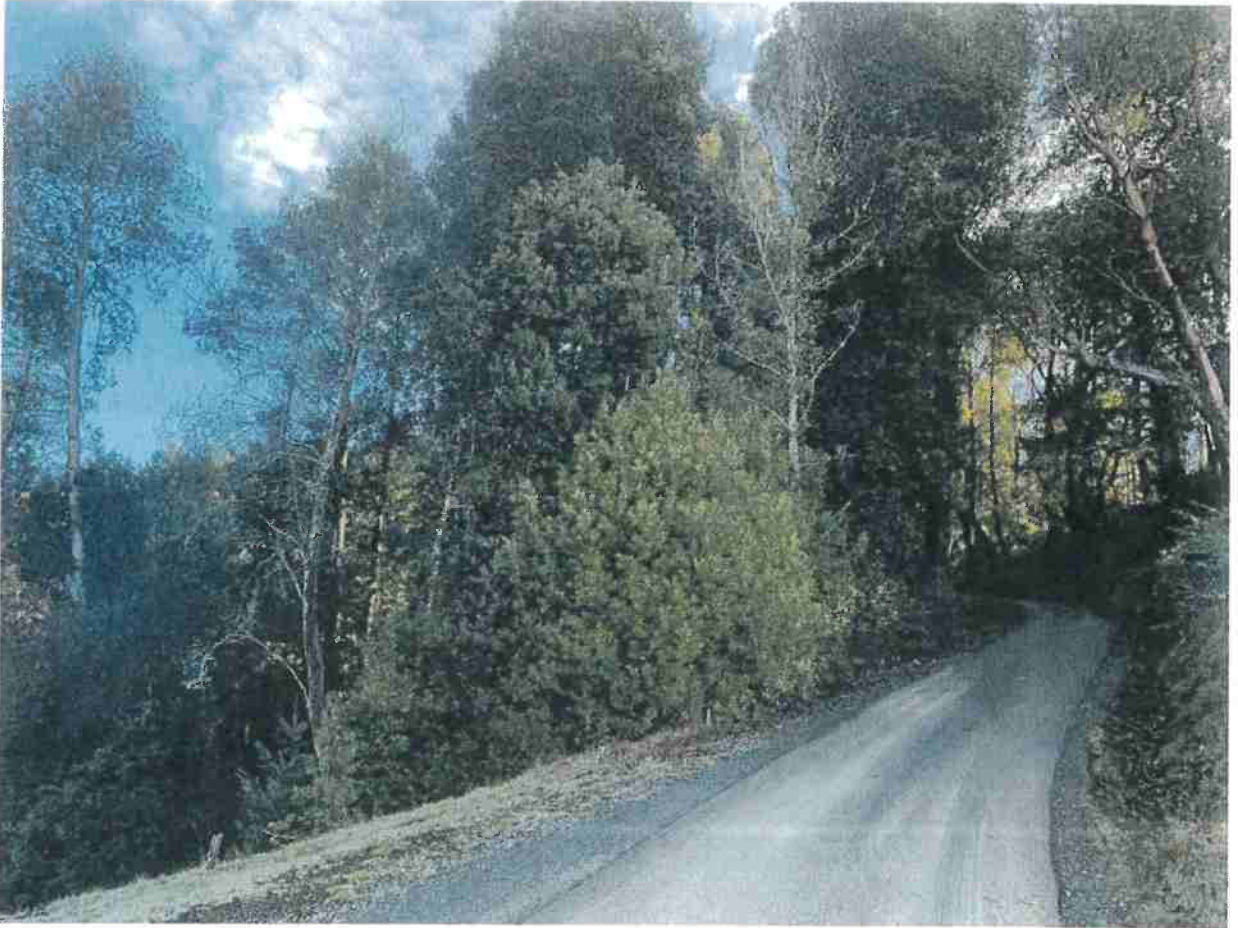

Photo 9: Dead, dying, and diseased tanoak infected with SOD located east of Site F along the permanent paved road. Photo date 1-17-2022.

Photos

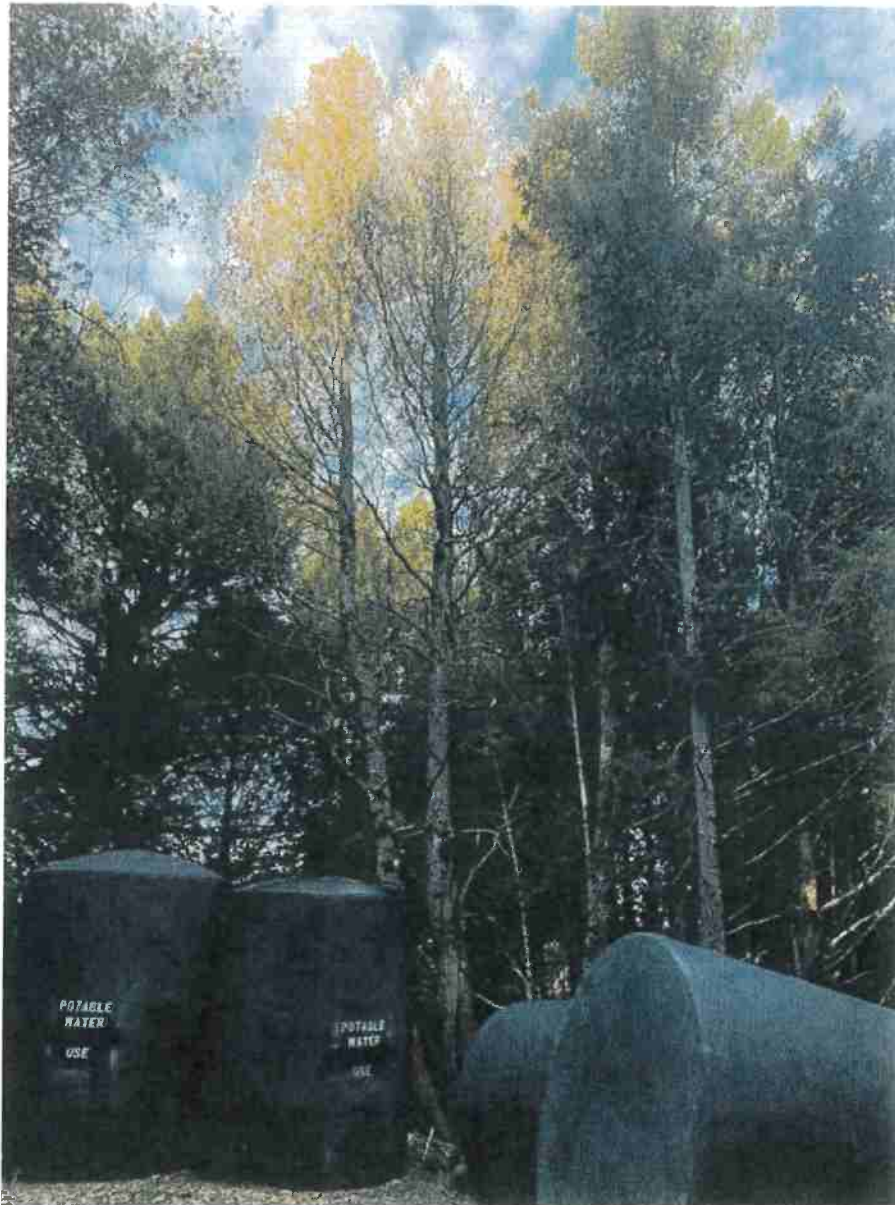

Photo 9: Dying and diseased tanoak infected with SOD located along the periphery of the Water Tank Farm. Photo date 1-17-2022.

Photos

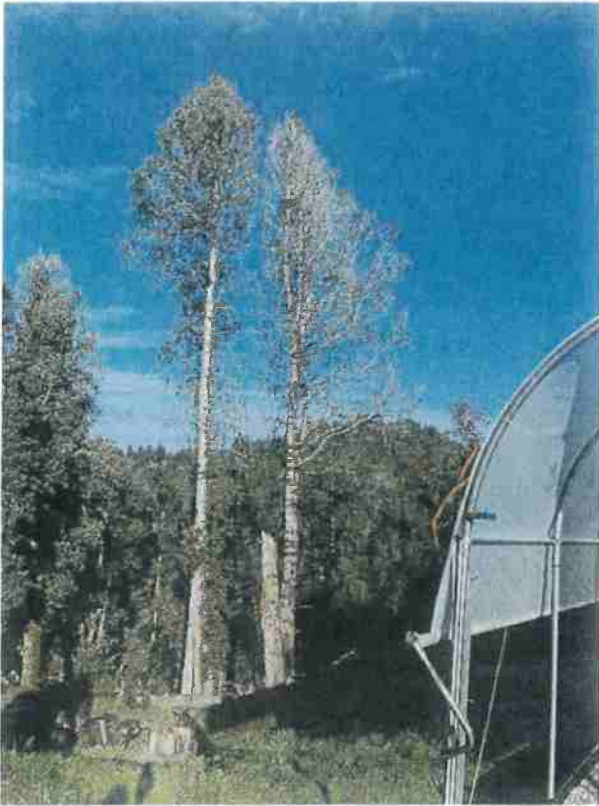

Photo 10: Dying and diseased tanoak infected with SOD located behind Site F. Photo date 1-17-2022.

MAP

APN 220-081-016

Location Map

 Property Boundary

Map Scale 1" = 2,000'
Section 21, T4S, R2E, HB&M

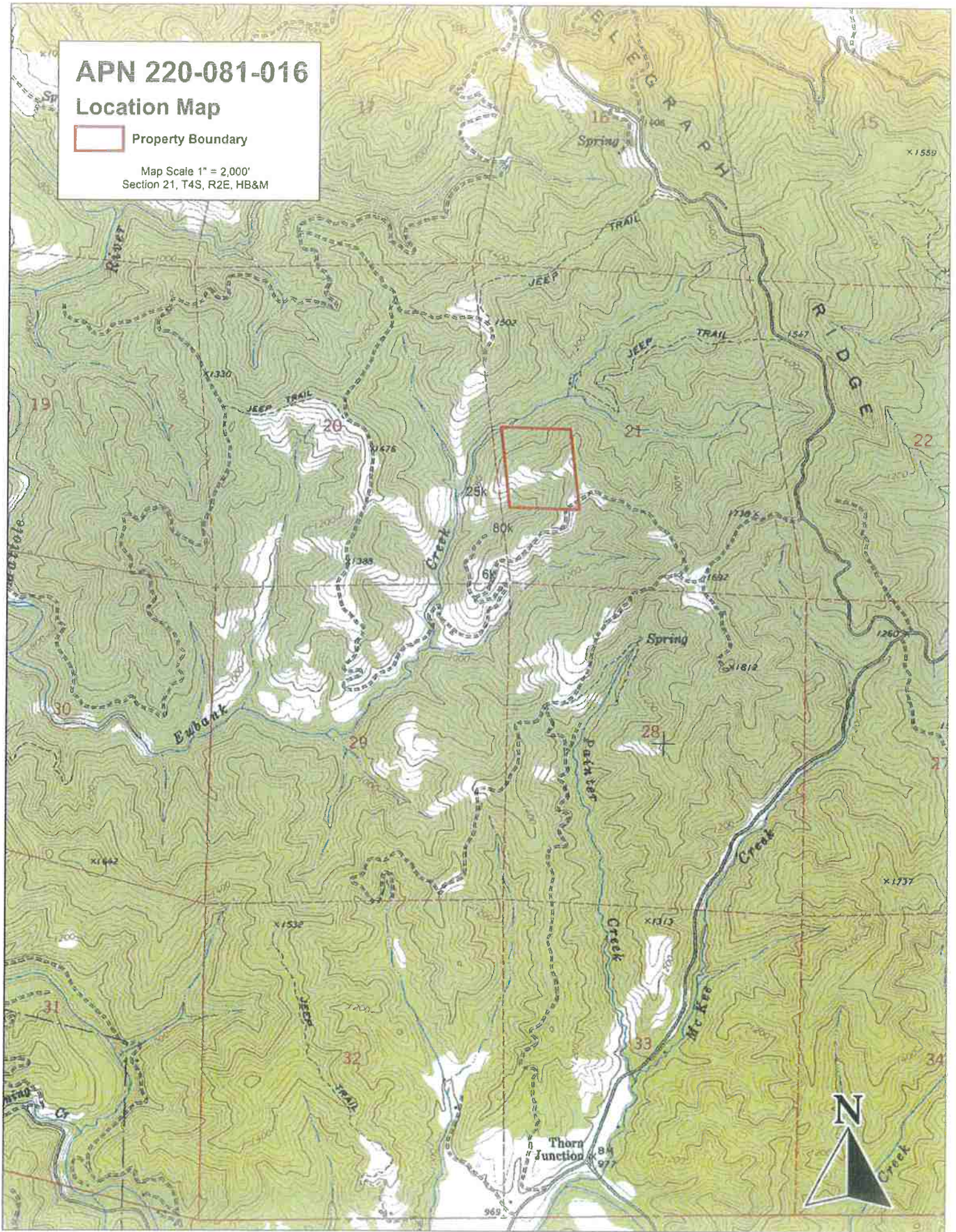



NORTH

APN 220-081-016

Conversion Evaluation Map

 Property Boundary

 Cultivation Site

 Eubanks Road

 Permanent Road

 Class III Watercourse

 Class II Watercourse

 Water Tank Farm

 Residence

 Shop / Garage

Map Scale 1 inch = 200 feet
Section 21, T4S, R2E, HB&M
Briceland USGS 7.5' Quad, C.1 = 40 feet

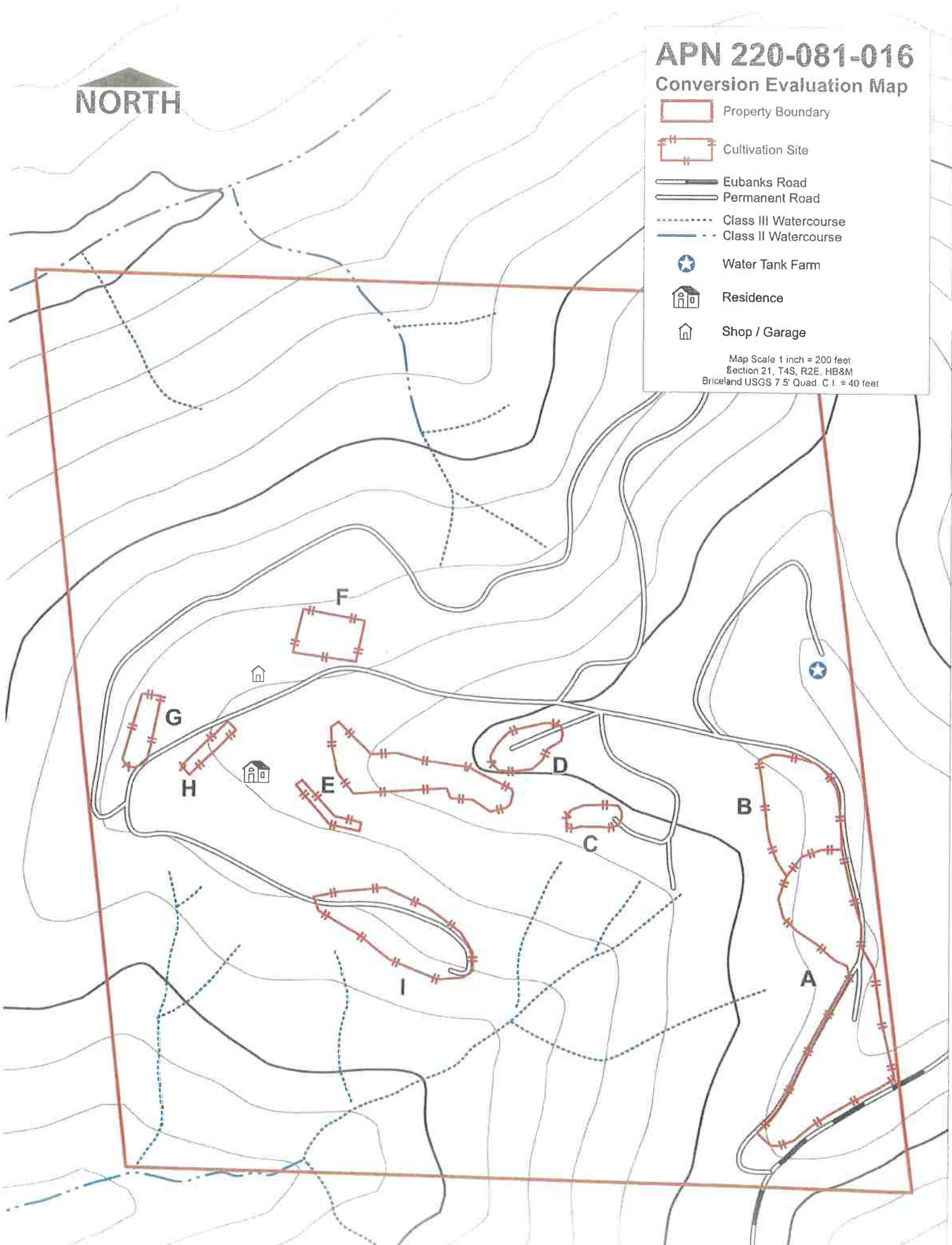

NORTH

APN 220-081-016

Conversion Evaluation Map

 Property Boundary

 Cultivation Site

 Eubanks Road

 Permanent Road

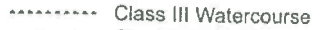
 Class III Watercourse

 Class II Watercourse

 Water Tank Farm

 Residence

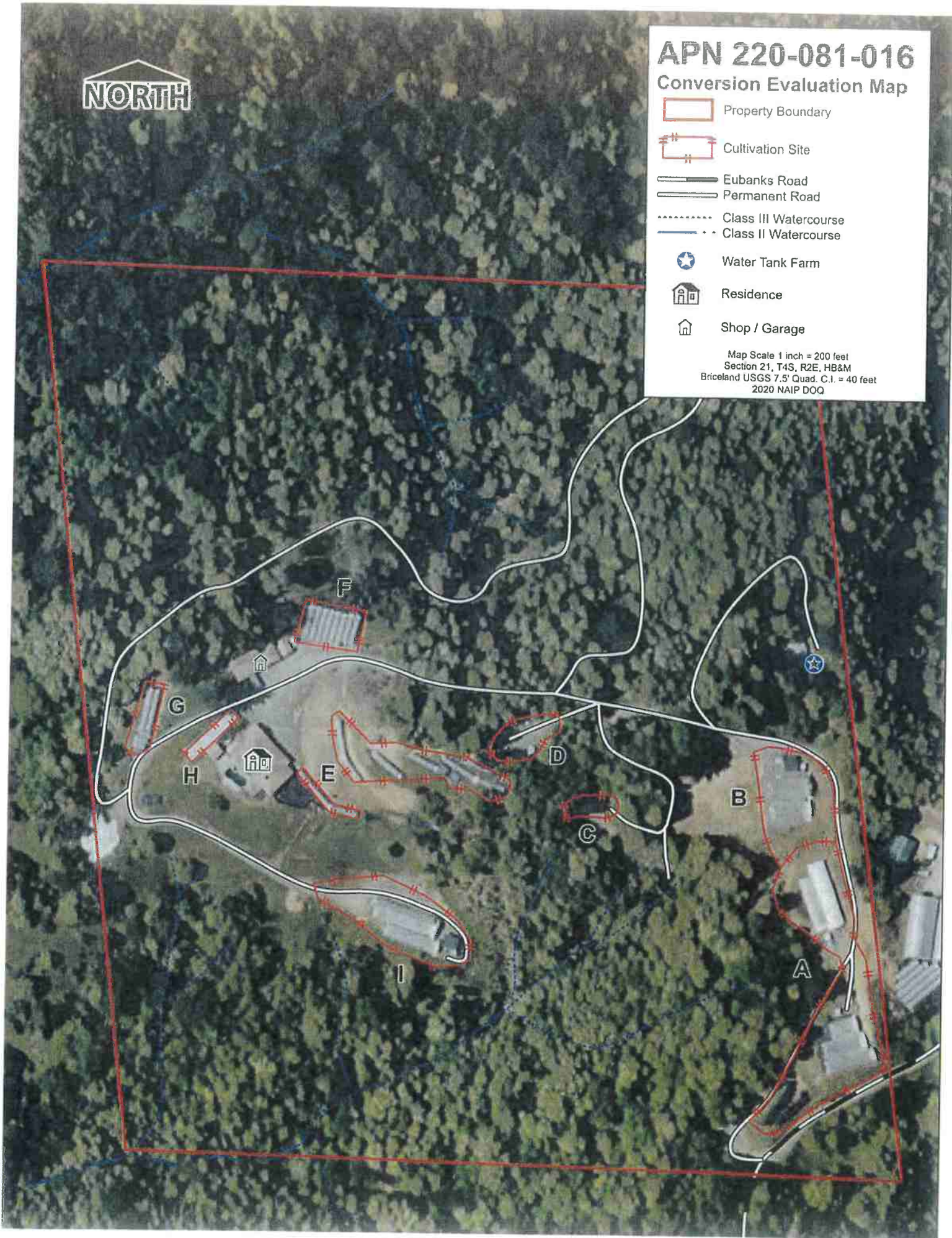

 Shop / Garage

Map Scale 1 inch = 200 feet
Section 21, T4S, R2E, HB&M
Briceland USGS 7.5' Quad. C.I. = 40 feet
2020 NAIP DOQ



APN 220-081-016

CNDDB Map

-  Property Boundary
-  0.7-Mile Biological Assessment Area
-  CNDDB Sensitive Species
-  NSO Activity Center

Map Scale 1" = 1,320'
Section 21, T4S, R2E, H8&M

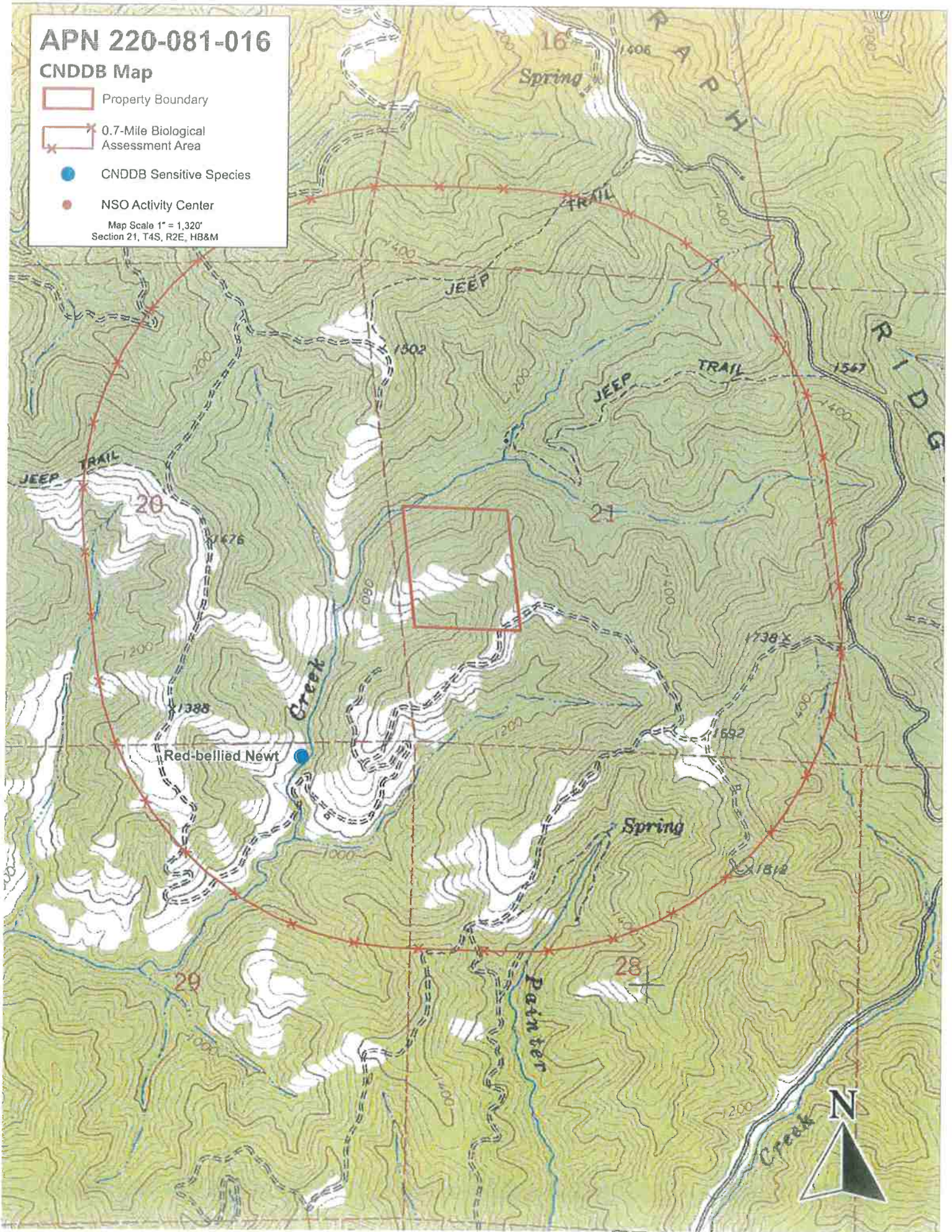

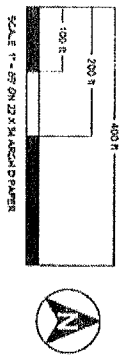
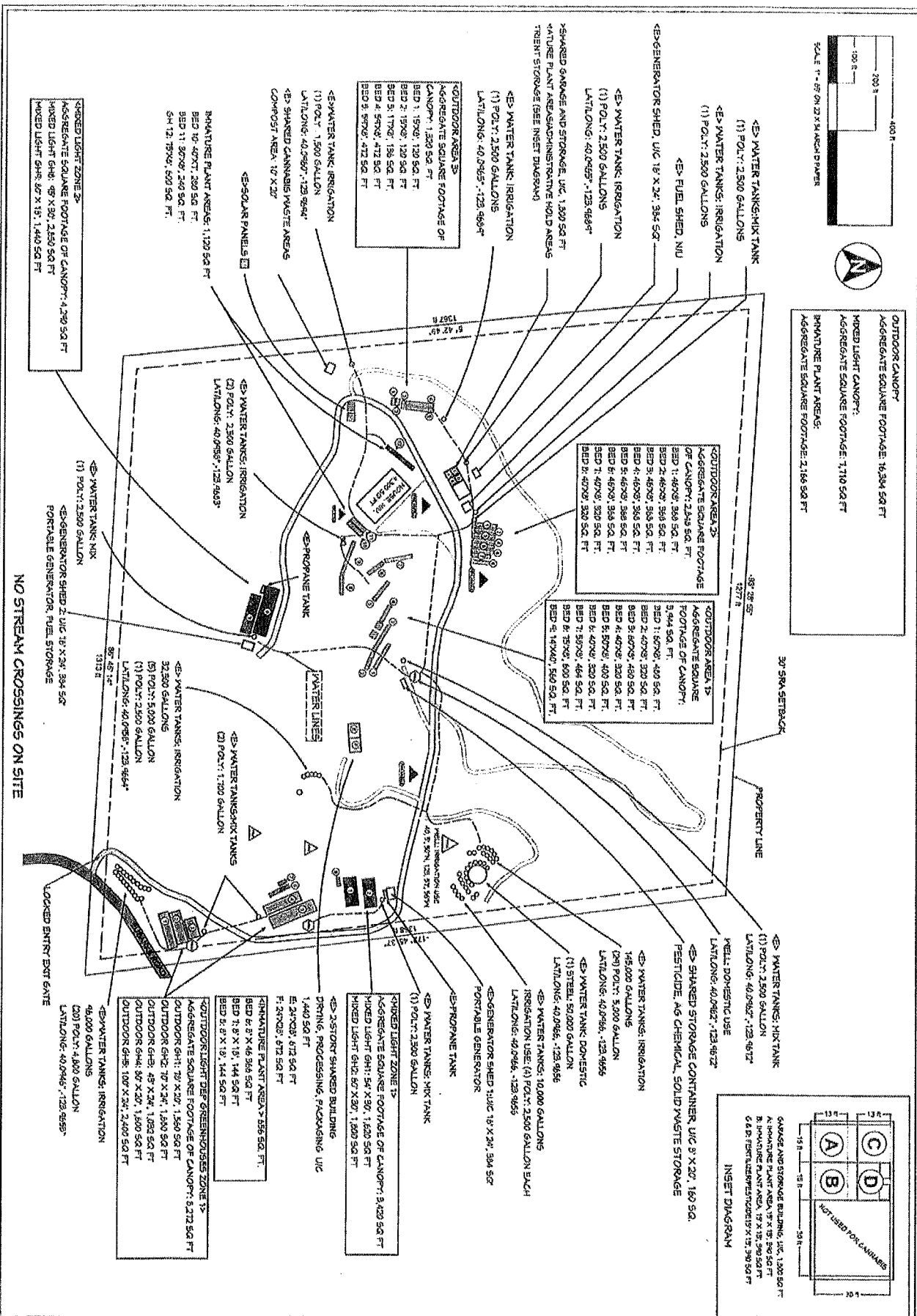

OUTDOOR CANOPY
 AGGREGATE SQUARE FOOTAGE: 16,394 SQ FT
 MIXED LIGHT CANOPY:
 AGGREGATE SQUARE FOOTAGE: 1,710 SQ FT
 RHIZOME PLANT AREAS:
 AGGREGATE SQUARE FOOTAGE: 2,188 SQ FT

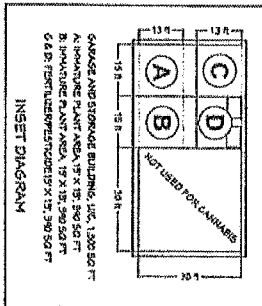

DRAWINGS PROVIDED BY:		PROPERTY DIAGRAM		REVISION TABLE	
NO.	DATE	NO.	DATE	NO.	DESCRIPTION

DATE: 1/13/2022
 SCALE: 1" = 50'
 SHEET: P-2

LOST COAST ELMS, LLC
 THOMAS HARNOOD
 PO BOX 196, REDWAY GA, 31556

A Homeowners Guide to Sudden Oak Death

A Homeowner's Guide to Sudden Oak Death

A plant disease commonly called Sudden Oak Death is threatening coastal forests in California and Oregon. Currently found in coastal California counties from Monterey to Humboldt and in a small portion of southwest Oregon, the disease is caused by the pathogen *Phytophthora ramorum* (pronounced Fi-TOFF-thor-ra ra-MOR-um). Sudden Oak Death has resulted in the death of millions of tanoak and coast live oak trees. In addition, more than 35 other plant species are susceptible to the pathogen, yet most of these species suffer only minor damage, limited to leaf spots or twig dieback. Though Sudden Oak Death is a forest disease, it is common in urban-wildland interface areas, so it presents many challenges for homeowners. This guide addresses homeowner concerns, including diagnosing infected trees, disposing of contaminated material, and understanding treatment options that are available.

What is the connection between Sudden Oak Death and nursery plants?

Many common horticultural plants are hosts for *Phytophthora ramorum*; consequently, nurseries in California, other states, and other countries, have found the pathogen on their plants. Plants are shipped all across the country, but they are strictly regulated. All *P. ramorum* host plants in California's regulated counties must be inspected and approved prior to shipment out of the regulated area. Nevertheless, carefully inspect the leaves of host plants for symptoms before making a purchase, and refrain from planting these horticultural hosts near susceptible oaks in your yard.

Because *P. ramorum* may be spread through the movement of infested soil and plant materials, State and federal regulations are in place to control the potential spread of the pathogen to uninfested areas. *P. ramorum* host species plant material is regulated by the California Department of Food and Agriculture (CDFA) and the U.S. Department of Agriculture, Animal and Plant Health Inspection Service (USDA-APHIS). Quarantine regulations are in place for the infested counties, and before moving susceptible plant material out of the regulated area, you must contact your Agricultural Commissioner for a permit.

If my oak tree has Sudden Oak Death, what are the chances it will die?

There is no way to determine if an individual tree will live or die after contracting Sudden Oak Death. Each tree responds differently to infection: experience tells us that it is rare for a tree pathogen to kill all of the trees it infects. Depending on a number of factors, some trees may never become infected, some may become infected and survive for various lengths of time, and others may become infected and die quickly. Because Sudden Oak Death is a relatively new disease in California, it will take time to determine just how likely different outcomes are for different tree species. Initial observations tell us that once infected, tanoak has a high probability of being killed by *P. ramorum*, but some individuals are still likely to survive. Coast live oaks appear to have a lower probability of being killed, though many have been killed by the disease. There is little mortality information on California black oak at this time, so it is difficult to predict how this tree species will fare.



California
Oak Mortality
Task Force

Hosts, Symptoms, & Diagnosis

Phytophthora ramorum affects different species in different ways. It can be lethal to tanoak, coast live oak, California black oak, Shreve oak, canyon live oak, and madrone saplings, while it may cause only a minor leaf or needle disease for other hosts such as California bay laurel, coast redwood, and Douglas-fir. The list of species and varieties known to be susceptible to this plant pathogen continues to grow; check suddenoakdeath.org for the latest updated host list.

How can I confirm that my oak tree has Sudden Oak Death?

Because other organisms and injuries can produce symptoms on oaks that look similar to Sudden Oak Death, homeowners will not be able to diagnose their trees by themselves with absolute certainty. However, there are some steps that can help you determine if *Phytophthora ramorum* is likely.

- (1) Determine if your oak tree is a susceptible species. To date, Sudden Oak Death has only been found on the following tree species in California: tanoak, coast live oak, Shreve oak, canyon live oak, and California black oak. Of these, tanoak is the species most likely to be killed.
- (2) Determine if you are in an infested area. Check the Sudden Oak Death mapping and monitoring site or contact staff in your local County Extension, Agricultural Commissioner, or California Department of Forestry and Fire Protection (CDF) offices. If you are outside of an infested area, your tree could still be infected with *Phytophthora ramorum*, but it would be less likely.
- (3) Compare the symptoms of Sudden Oak Death with those on your oak tree. Check other susceptible tree and shrub species nearby. Do they have leafspots or other symptoms of *P. ramorum*? California bay laurel is the best indicator of the risk and presence of the disease. Photos of symptoms on oaks, California bay laurel, and other hosts can be found at suddenoakdeath.org.

The probability that your tree is infected with *Phytophthora ramorum* will be greater if your tree is a susceptible species, exhibits typical symptoms, and is located in an infested area where other trees and plants are showing symptoms. Although positive confirmation can only be done through laboratory testing, diagnosis of *Phytophthora ramorum* based on visual symptoms can justify taking preventative action if you live in a generally infested area. If you ask a tree care professional to make such a judgment, determine what training or qualifications enable them to do this.



Bleeding cankers on a coast live oak trunk (Photo by Mauro Carbelotto, University of California, Berkeley)



Bleeding cankers on a tanoak trunk (Photo by Pavel Sulima, UC Cooperative Extension)

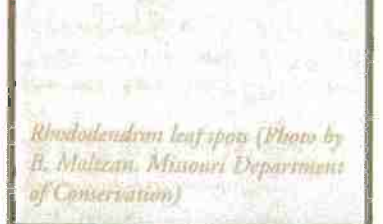

Rhododendrum leaf spots (Photo by B. Mulzean, Missouri Department of Conservation)



(Left) California bay laurel showing leaf spots typical of *P. ramorum* (Photo by Bruce Mulzean, Missouri Department of Conservation)
(Right) California bay laurel leaf spots (Photo by Mauro Carbelotto, University of California, Berkeley)



Treatments: A phosphonate compound is registered as a preventative treatment for *Phytophthora ramorum*, for use on individual, high-value tanoak and oak trees. This treatment is NOT a cure, but can help protect trees from infection, as well as suppress disease progression in very early infections. However, fungicide treatment of *P. ramorum*-infected trees is not always appropriate. Trees with advanced symptoms cannot be saved.

The phosphonate compound may be injected or mixed with a surfactant and sprayed on the trunk for absorption through bark. The optimal treatment routine for coast live oaks calls for two applications the first year followed by one application annually thereafter. It is recommended to treat in either the fall then spring, or spring then fall the first year. Follow up treatments should be only in the fall annually (avoid treatments when temperatures are very low). If risk is minimal, meaning low abundance of infections or host species in the area, follow up treatments can be bi-annual.

Since the treatment must be made to healthy trees, and the pathogen's distribution and activity is patchy and somewhat unpredictable, it is difficult to determine which trees need to be treated. Generally, you should treat healthy, high-value oak or tanoak trees within 150ft of other infested plants. You may want to treat healthy, high-value oaks or tanoaks if they are surrounded by healthy California bay laurel and there are known infections between 150ft and 1000ft away. Treatment is NOT recommended in areas where infested plants are not already present. Although these treatments are best used as a preventative approach, it may be possible to prolong the life of trees already infected by *P. ramorum*. Research results indicate that treatments are effective only if trees are treated within the first two months of infection. Treatment of trees having displayed symptoms for six months or longer is not recommended.

Exactly how the pathogen spreads to oak trees is unknown, but it is suspected that neighboring non-oak host plants may be a source of infection for oak trees. However, because this relationship is poorly understood, large-scale removal of non-oak host plants is not being recommended as a way to prevent disease spread. Currently, it may be best to plant non-*Phytophthora ramorum* hosts under or adjacent to oak trees. Rhododendron, for example, is a commonly planted ornamental that is a host for *P. ramorum*, and it is possible that an infested rhododendron could infect a nearby oak. Additionally, the summer watering necessary to keep lawns and non-native ornamental shrubs, such as camellias, alive under an oak tree severely predisposes the oak to other diseases.

The use of insecticides to prevent *P. ramorum* infection is unjustified and without merit. However, the treatment of individual, high-value landscape trees displaying early bleeding symptoms of Sudden Oak Death may be justified to control damage from secondary bark beetle attacks. If an insecticide is to be used, apply it only if the disease is not at an advanced stage and realize it may only prolong the life of the tree for a relatively short period of time.

Tree Removal: A tree with Sudden Oak Death needs to be considered and treated differently than a tree without the disease, but the disease alone is not justification for removing a tree. Current information indicates that non-oak foliar hosts contribute the most to disease spread, so removing infected oak trees will probably have little or no impact on local disease levels and spread. However, an important consideration with respect to any tree is whether or not it presents a hazard to life or property. All trees present some hazard, depending on the tree's structural integrity and its potential to do harm should it fail or portions break off. Preliminary research has shown that trees infected or killed by *P. ramorum* are prone to rapid decay and unpredictable failure. Green infected trees, as well as trees already dead from *P. ramorum* and/or secondary pests, are at increased risk of trunk and limb breakage.

Who should I hire to treat my trees?

The COMTF has held many training sessions for tree care professionals in California. A list of those training participants can be found on the COMTF website. Go to suddenoakdeath.org to find a professional in your area who has attended a general diagnostic training session or a training session on applying the registered preventative chemical treatment. While they have been trained, it is still important to ask for references, as well as to interview the arborist and applicator to see if they are up-to-date on the latest *Phytophthora ramorum* management strategies.

The decision to remove a hazardous tree ultimately lies with the property owner. In order to get an objective assessment of hazardous conditions, contact a certified arborist or other qualified professional. Any dead tree has an increased risk of failure, but even dead trees have value, and if there is not a risk to life or property, consider leaving it standing. Standing dead trees provide important wildlife habitat, and after they fall and decay, they are a source of nutrients to be recycled into the soil.

Always consult regulatory officials regarding local tree ordinances before deciding to remove trees. Experienced tree service technicians should conduct tree felling, as infected trees may have an abundance of structural wood decay. If there is an acute emergency, contact your city arborist, local fire, or police department.

If I have an infected oak tree cut down, what should be done with the wood?

The simplest and best way to deal with infested wood is to leave it on site, chipping the smaller pieces of wood for use as mulch, and splitting the larger pieces of wood for firewood. Do not stack oak firewood next to living oak trees since this can lead to insect attack on the living trees. If the stack must be next to living trees, consider seasoning the logs beneath a tightly sealed, clear plastic tarp to prevent the buildup of destructive insects.

What should be planted to replace a tree that was killed by *Phytophthora ramorum*?

If you want to replant, it is important to choose a plant that will suit your needs and adapt well to the site. There are many resources available that can guide you in making the right choice. Check to see if there are any local ordinances or guidelines that govern tree replacement or planting.

Resistance to *P. ramorum* in oak trees is just beginning to be explored. Resistant planting stock is not available at this time, nor is it known if it will ever be available. If you want to replant the same species of tree that was lost, there is a risk that the new tree may also suffer from the disease. If you have space for replanting many trees, consider replanting the same species in combination with other trees that don't get the disease. Thus, if some trees are lost to *P. ramorum* there will still be other trees that survive. Coast live oaks do not seem to be infected by *P. ramorum* until they reach about 4" in diameter, so new trees should be immune for a number of years, and high value trees can be treated if necessary once they reach a susceptible age. Species in the white oak group such as valley oak, Garry oak, and blue oak are not susceptible to *P. ramorum*.

Many common ornamental plants, such as rhododendrons, azaleas, and camellias, are also known hosts of *P. ramorum*. These plants not only can host spores that may infect oak trees, but their watering requirements are vastly different than those of California native oaks. We do not recommend planting these species under or near native oaks.

If infected wood is removed from your property, make sure it is utilized or disposed of in a way that does not spread the disease. Avoid leaving wood next to roads where it could be picked up and transported off-site by unauthorized parties. Regulations prohibit the movement of host plants and plant parts out of the quarantined area. If you have infected trees cut down, make sure the wood and other tree parts are not moved outside of the quarantine area.

Debris Disposal:

Disposal of infested material is extremely important because branches, twigs, and leaves from California bay laurel, rhododendron and other host plants may harbor *P. ramorum*, even after they are removed from the plant. If infested plant debris

or infected live plants are moved, they may inadvertently transfer the pathogen to uninfested areas. Unfortunately, *P. ramorum* has been present in many areas of coastal California for a decade or longer, making complete eradication impossible. In infested areas, the best option is to leave infested material on site, chipping the small material (for use as ground cover) and using larger pieces for firewood. Composting can also successfully kill the pathogen, but the compost must reach temperatures that are probably not possible or practical in a home composting site. Since inoculum levels are already thought to be high, leaving the additional inoculum from the infested plant material on site will not significantly worsen the local disease conditions. Plant debris removal from the property is only recommended if it is the first infected tree to be detected in the area, or if fire risk is high.

7/14/17



165 South Fortuna Boulevard, Fortuna, CA 95540
 707-725-1897 • fax 707-725-0972
 trc@timberlandresource.com

Stormwater Management Plan For APN 220-081-016

This Stormwater Management Plan addresses Items 2.14 and 2.15 of the Landowner's Draft Lake and Streambed Alteration agreement with CDFW (Agreement No. 1600-2016-0436-R1). Map Points 2, 2.5, 5, 6, and 6.5 below address the sediment discharge and runoff connectivity identified during site visits with CDFW in December 2016 and with the Regional Water Quality Control Board Staff on 6/13/17.

Map Point 2 - Rocked Lined Ditches: Map Point 2 is a segment of a rocked inside ditch approximately 150 feet in length. Runoff originating from an existing ditch relief culvert and from a developed, cultivation area upslope, converge at the north end of the rocked inside ditch shown as Map Point 2. During rain storms, runoff is carried southerly to the end of the rocked ditch where it drains into the Class III watercourse. The road surface is slightly outsloped along this segment so surface drainage does not contribute to the volume of flow in the rocked ditch. During heavy rain storms, runoff escapes the ditch and flows over erodible fills at its end, directly above the Class III watercourse. The Discharger has recently installed erosion control netting on the slope of the fill off of the end of the road, and has rock lined the inside ditch along the area shown as Map Point 2. The Discharger has also rock lined the two road and development drainage flow paths that converge at the inside ditch from above. The northern one of these rocked lined drainages extends from the outlet of an existing ditch relief culvert. The other extends from a rolling dip at the northwest corner of the cultivation area. The two drainages that converge at the north end of Map Point 2 are shown on the WRPP Map.

The most feasible mitigation for the connected road segment at Map Point 2 is to reduce the amount of flow that drains to the rock lined inside ditch. Mitigations for the connected road segment were discussed at length during a site visit on 6/13/17 with landowner representatives and Water Quality Control Board personnel. Due to the amount of existing development on this property, options for reducing flows are limited. The bullet points below address connectivity and reduce the amount of concentrated runoff coming from development.

- The existing ditch relief culvert (E DRC on the WRPP Map) that outlets at the top of the rock lined drainage shall remain in place and functional as it is and maintain the current road surface grading pattern upslope. This ditch relief culvert currently drains a short segment of roadside ditch and very little of the road surface. Upslope of this ditch relief culvert the road surface is outsloped to crowned and is not contributing a significant amount of drainage to the rock lined ditch segment at Map Point 2. The rock lined drainage below the outlet of the ditch relief culvert has check dams in place along its length.

7/14/17

- Install a rain gutter / rain catchment system on the two greenhouses east of the rock lined inside ditch at Map Point 2. This will reduce the amount of drainage that currently flows to the top of the rock lined ditch. During the wet season, the rain gutters will be plumbed to holding tanks that can be pumped up to the existing water storage tanks that are currently supplied by wells on the property. Additional water storage tanks may be added by the Discharger. Rain catchment can be disconnected during the summer so that collecting accumulated dust on rooftops can be avoided. First flush rains can be routed to non-erodible vegetated surfaces at least 100 feet from the watercourses. Rain catchment expected from these guttered greenhouses are estimated to be approximately 1,870 gallons (250 cubic ft) of water per 1" of rainfall. Rain catchment overflows will be clean rooftop water routed to non-erodible vegetated surfaces or returned to the Class III watercourses down slope in the same drainage. During a typical one inch per hour rainfall, rain catchment overflows would be approximately 0.07 cubic feet per second. Overflows during rains can be further minimized by irrigating and using water via draining of storage tanks and not refilling from the wells when there is a prediction of rains in the near future. Well water should be used to refill storage during times of little or no rainfall.
- The rock lined drainage that extends from the northwest corner of the cultivation area and converges down to the rock lined ditch at Map Point 2 shall be disconnected from draining of the flat through a raise in the grade and eliminating the existing rolling dip along the edge of the cultivation area. Drainage through this area will be accomplished through outsloping with a series of drainage outs to evenly disperse drainage rather than having it remaining concentrated and draining to the rock lined drainage.
- A rolling dip shall be installed across the road surface approximately 20 to 30 feet north of the downslope end of the segment labeled Map Point 2 on the WRPP Map. This will be done to drain the road surface and the rock lined ditch, westerly away from the erodible fills off of the end of the road and to disconnect the rock lined ditch from its current connection with the watercourse. The slightly outsloped road surface shall remain as it is so that it does not contribute drainage to the rock lined ditch. The previously placed rock cobble extending to the watercourse shall be removed. Grass and vegetation have become reestablished on the fill slope off of the end of the road. Leave as much of this vegetation intact as possible.

Map Point 2.5 – French Drain and Rock Lined Ditch: Map Point 2.5 is a recently rock lined drainage channel that extends from the outlet of a "French Drain" that exists under the developed mixed light cultivation area. The rock lined drainage extends downslope for approximately 100 feet and ends just above the head of a Class III watercourse and a Class II spring that is also a POD.

The areas adjacent to the rock lined channel had been previously lined with "jute" netting and covered with straw. The application of rock to the drainage ditch and the adjacent erosion control had just recently been installed prior to a site visit with CDFW on 12/2/16. No erosion was observed at the site, but it had not yet experienced prolonged, heavy precipitation. Mitigations for this site were discussed at length during a site visit on 6/13/17 with landowner representatives and Water Quality Control Board personnel.

The bullet points below address connectivity with the French drain outlet.

- The four inch diameter flex pipe that is the outlet of the French drain shall be plumbed to a subsurface waste water infiltration system. It shall be located on the gentle slopes to the northwest of Map Point 2 and at least 100 feet away from the nearest watercourse.

7/14/17

- The Discharger shall refrain from staging immature potted plants at the top of the rock lined drainage at Map Point 2.5.
- The surface of the cultivation area above this rock lined drainage shall be outsloped to disperse drainage evenly rather than having it remaining concentrated and draining to the rock lined drainage.

Map Point 5: The road segment identified as Map Point 5 is approximately 120 feet in length in which surface runoff from the road, drains off of the road easterly, at a natural low spot that is approximately 60 feet above the top of a Class III watercourse. This area is shown as Map Point 5 on the WRPP Map. Although it does not appear to be a significant source of sediment, it is a hydrologically connected road segment. The road surface along this segment is rock lined and is rutting. In order to reduce the amount of road runoff that drains to the head of the Class III watercourse, the Discharger shall outslope this road segment and install a rolling dip to drain the road surface away from the Class III watercourse as much as is feasible. This is expected to significantly reduce the amount of road surface runoff reaching the Class III watercourse southeast of Map Point 5.

Map Point 6 and 6.5: Map Point 6 is a segment of a road and cultivation area that is hydrologically connected to a Class III watercourse via an inside ditch. This road segment is approximately 100 feet long and the connected ditch beyond the end of the road is approximately 50 to 60 feet and is located on a historic logging skidtrail down to the Class III watercourse. A gully has now formed along the lower end of this connected drainage.

This connected ditch is also transporting sediment from the outdoor cultivation area above the road between Map Points 5 and 6. Runoff from recent heavy rainfall deposits sediment from the terraced cultivation area down onto the road surface and inside ditch along the segment shown as Map Point 6.

The terraced slopes above the road between Map Points 5 and 6 have begun to slump. The Discharger has covered these developed, terraced slopes with plastic and tarps to protect them from precipitation and more slumping. This protects the slopes but leads to more runoff into the ditch at Map Point 6 during rains. The Discharger has hired an engineer and an experienced operator to plan, permit, and reconfigure the slumping developed, terraced slopes, and to improve drainage between Map Points 5 and 6.

The Discharger, the engineer, and the operator are all aware of the Order and the need to reduce sediment and disperse runoff. Mitigations for the connected road segment were discussed at length during a site visit on 6/13/17 with landowner representatives and Water Quality Control Board personnel. During this site visit, a recent slump of old fill material close to a watercourse was discovered for the first time. It likely occurred in April of 2017 during heavy spring rains. It is shown as Map Point 6.5 on the WRPP Map.

The bullet points below address Map Points 6 and 6.5.

- Stabilize the terraced slopes above the road between Map Points 5 and 6. Excavate, reconstruct, and compact these terraced slopes. Rock armoring of cut banks and fill slopes may take place as determined by the engineer or the operator.

- Drainage shall be incorporated into the terrace surface by outsloping to promote even dispersal rather than concentration. Outsloping will be directed westerly as much as possible to reduce the amount runoff to the drainage at Map Point 6. A French drain and a subsurface waste water infiltration system could be installed similar to that described above at Map Point 2.5. A waste water infiltration system, if installed, shall be located on gentle slopes and at least 100 feet away from the nearest watercourse.
- Install a rain gutter / rain catchment system on any existing and future greenhouses near Map Point 6 to reduce surface runoff. During the wet season, the rain gutters will be plumbed to holding tanks that can be pumped up to the existing water storage tanks that are currently supplied by wells on the property. Additional water storage tanks may be added by the Discharger. Rain catchment can be disconnected during the summer so to avoid collecting dust on rooftops. First flush rains can be routed to non-erodible vegetated surfaces at least 100 feet from the watercourses. Rain catchment overflows will be clean rooftop water routed to non-erodible vegetated surfaces or returned to the Class III watercourses down slope in the same drainage. Overflows during rains can be further minimized by irrigating and using water via draining of storage tanks and not refilling from the wells when there is a prediction of rains in the near future. Well water should be used to refill storage during times of little or no rainfall.
- Along the segment of the drainage path adjacent to the road at Map Point 6, install loose rock check dams. Upon completion of stabilization work at Map Point 6.5 described in the next bullet point below, install a pipe to collect Map Point 6 drainage prior to it leaving the road. The pipe shall be routed southwesterly across the Map Point 6.5 area, and drained to the forest floor via a perforated segment.
- Stabilize the recently slumped old fills at Map Point 6.5. Unstable fills shall be excavated, recontoured, and compacted. Slopes shall be recontoured as close as possible to the natural grade and aspect. Bare mineral soil shall be treated immediately following completion of earthwork per the Erosion Control BMP below.

Erosion Control BMPs:

- Erosion control and sediment detention devices and materials shall be installed prior to the end of project work and before the beginning of the rainy season.
- Non-invasive, non-persistent grass species (e.g. barley grass) shall be used for their temporary erosion control benefits to stabilize disturbed areas and prevent exposure of disturbed soils to rainfall.
- Cover all exposed soils with straw mulch and erosion control seed mixture. Install fiber rolls at a maximum vertical spacing of 5 feet.
- Upon work completion, all exposed soil present in and around the work sites shall be stabilized within 7 days.
- The site shall be planted with Douglas-fir and/or redwood in the first winter following restoration activities at an approximate 10' x 10' spacing.

Pictures



Pictures 1 and 2: These are the pictures taken along the segment of Map Point 2 prior to the recent rock lining of the inside ditch. The picture on the left shows the south end of the road segment identified as Map Point 2 on the WRPP Map. The picture on the right is taken from south end of this road segment and is looking up the road in a northerly direction. The recent October rainfall has caused the runoff to overflow the inside ditch and over the fill at the end of the road. The Discharger had recently installed erosion control "Jute" Netting on the face of the road fill. Photo date 11/3/2016

Pictures



Picture 3: This is a picture of the newly rock lined drainage channels located upslope of Map Point 2. The channel on the left extends from the outlet of an existing ditch relief culvert. The channel on the right extends from the surface of the developed cultivation area. Photo date 12/2/2016

Pictures



Pictures 4 and 5: These pictures show the bottom of the newly rock lined drainage channels and where they intersect with the newly rock lined inside ditch along Map Point 2. Photo date 12/2/2016

Pictures



Picture 6: This is a picture along Map Point 2 showing the bottom half of the newly rock lined inside ditch taken from near the location of picture 2 above. Photo date 12/2/2016

Pictures



Picture 7: This is a picture at the end of the road where the rock lining of the ditch ends at the south end of Map Point 2. Photo date 12/2/2016

Pictures



Pictures 8 and 9: The picture on the left shows recently widened and rock lined ditch. A rolling dip shall be installed just prior to the end of the road, to drain the road surface and the ditch towards the right so that it no longer can drain over the fill slope straight off of the end of the road. The picture on the right shows the grassed over jute netting placed on the fills beyond the end of the road. Photo date 2/13/2017

7/14/17

Pictures



Picture 10: This is a picture of the newly rock lined drainage ditch (Map Point 2.5) that drains a "French drain" outlet that collects from the surface of the developed cultivation area. It ends above a swale that contains the top of a Class III watercourse and a Class II spring and POD. Photo date 12/2/2016

7/14/17

Pictures



Picture 11: This is a picture of some of the leftover rock armoring along the connected inside ditch drainage that is shown as Map Point 6. Mitigation for this connected inside ditch segment is stated in detail in the assessment above. It involves dispersal of surface flows and rain catchment off of buildings to reduce runoff, and piping remaining ditch flows away from the watercourse to disperse on the forest floor. Photo date 11/3/2016

7/14/17

Pictures



Pictures 12 and 13: These are pictures taken at the southeast of Map Point 6. It shows the eroded gully between the end of the road and the Class III watercourse. The dog in the picture on the right is pointing up the natural Class III watercourse. Photo date 12/2/2016

Pictures



Pictures 14 and 15: These are pictures of the area of Map Point 6 on the WRPP Map. The straw wattles were recently installed to trap sediment from reaching the watercourse beyond the end of the greenhouse in the picture. The terraced area in the left half of the picture is slumping slightly and will be re-configured as stated in the report. Photo date 2/13/2017

7/14/17

Pictures



Picture 16: These are pictures of the recently slumped fill material shown as Map Point 6.5 on the WRPP Map. Slopes shall be recontoured as close as possible to the natural grade and aspect. Photo date 6/13/2017

7/14/17

BMP: Ditch Relief Culvert

- Install ditch relief culverts at an oblique (typically 30 degree) angle to the road so that ditch flow is not forced to make a sharp angle turn to enter the pipe. On low gradient roads (<5%), where ditch flow is slow, ditch relief culverts can be installed at right angles to the road.
- Install ditch relief culverts (DRC) to outlet at, and drain to, the base of the fill.
- If it cannot be installed at the base of the fill, install the DRC with a grade steeper than the inboard ditch draining to the culvert inlet, and install a downspout on the outlet to carry the culverted flow to the base of the fillslope.
- Downspouts longer than 20 feet should be secured to the hillslope for stability.
- Ditch relief culverts should not carry excessive flow such that downcutting of the ditchline or gullying below the outlet occur.
- Do not discharge flows from ditch relief culverts onto unstable fill or active landslides.
- If the ditch is on an insloped or crowned road, consider using outsloping to drain the road surface. The ditch and the ditch relief culvert would then convey only spring flow from the cutbanks and hillslope runoff, and not turbid runoff from the road surface.

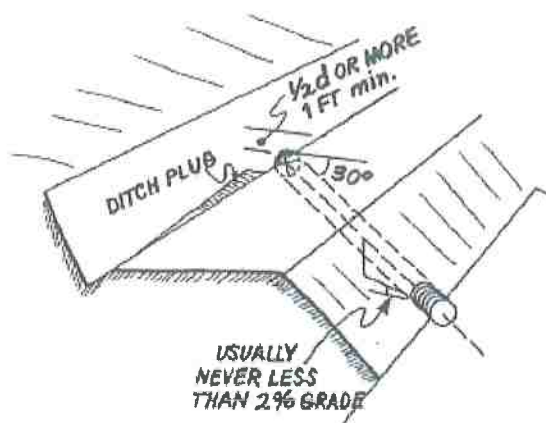
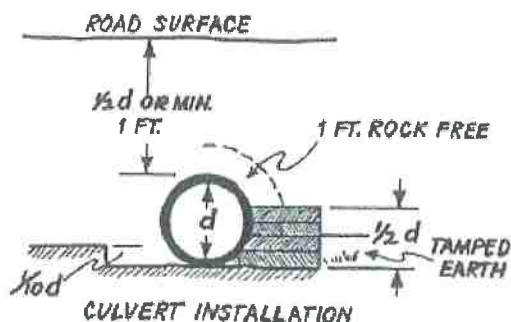

FIGURE 48. The elements of a properly installed ditch relief culvert. The culvert is angled at about 30 degrees to the road alignment to help capture flow and prevent culvert plugging or erosion of the inlet area. It is set at the base of the fill (ideally) or with a grade slightly steeper than the grade of the contributing ditch (but never with a grade less than 2 percent) (USDA-SCS, 1983). At a minimum, the grade of the ditch relief culvert should be sufficient to prevent sediment accumulation at the inlet or deposition within the culvert itself (it should be self-cleaning) (USDA-SCS, 1983).



HANDBOOK FOR FOREST, RANCH AND RURAL ROADS

7/14/17

BMP: Rolling Dip

- Rolling dips are drainage structures designed to capture and discharge surface water collected on road surfaces and in inside ditches at a specific location.
- The road shall dip into and out of the rolling dip to eliminate the possibility of water flowing along the road surface or in an inside ditch to bypass the dip structure.
- The rolling dip shall be constructed with clean native materials.
- The rolling dips outlet may be armored to resist downcutting and erosion.
- Do not discharge rolling dips into swales that show signs of instability or active landsliding.
- If the rolling dip is designed to divert both road surface and ditch runoff, block the down-road ditch with compacted fill.

BMP: Rocked Rolling Dip

- Rocked Rolling dips are drainage structures designed to capture and discharge surface water collected on road surfaces and in inside ditches at a specific location.
- The road shall dip into and out of the rolling dip to eliminate the possibility of water flowing along the road surface or in an inside ditch to bypass the dip structure.
- The rocked rolling dips inlet and outlet shall be armored to resist downcutting and erosion.
- The entire length of the rocked rolling dip shall be rock armored to a minimum of 5-feet from the centerline of the dip.
- If a keyway is necessary, the rocked rolling dip keyway shall be constructed at the base of the dip and shall be of sufficient size, depth, and length to support materials used in the rocked rolling dip construction back up to the road crossing interface.
- Do not discharge rolling dips into swales that show signs of instability or active landsliding.
- If the rolling dip is designed to divert both road surface and ditch runoff, block the down-road ditch with compacted fill.
- The rolling dip must be drivable and not significantly inhibit traffic and road use.

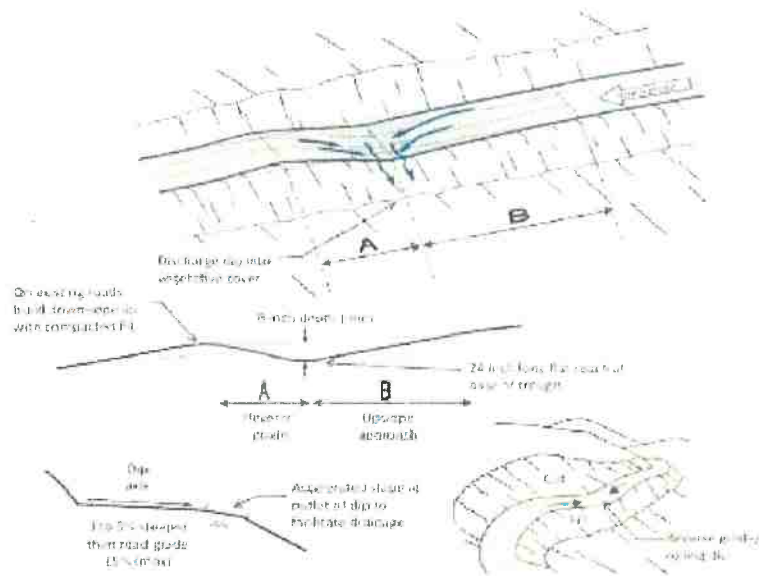

FIGURE 34. A class: Type I rolling dip, where the excavated up-road approach (B) to the rolling dip is several percent steeper than the approaching road and extends for 60 to 80 feet to the dip axis. The lower side of the structure reverses grade (A) over approximately 15 feet or more, and then falls down to rejoin the original road grade. The dip must be deep enough that it is not obliterated by normal grading, but not so deep that it is difficult to negotiate or a hazard to normal traffic. The outward cross-slope of the dip axis should be 3% to 5% greater than the up-road grade (B) so it will drain properly. The dip axis should be out-sloped sufficiently to be self-cleaning, without triggering excessive downcutting or sediment deposition in the dip axis (Modified from: Best, 2013).

HANDECOX FOR FOREST RANCH AND RURAL ROADS

APN 220-081-016

Location Map

 **Property Boundary**

Map Scale 1 inch = 2,000 feet
Section 21, T4S, R2E, HB&M
BriceLand USGS 7.5' Quad. C.I. = 40 feet

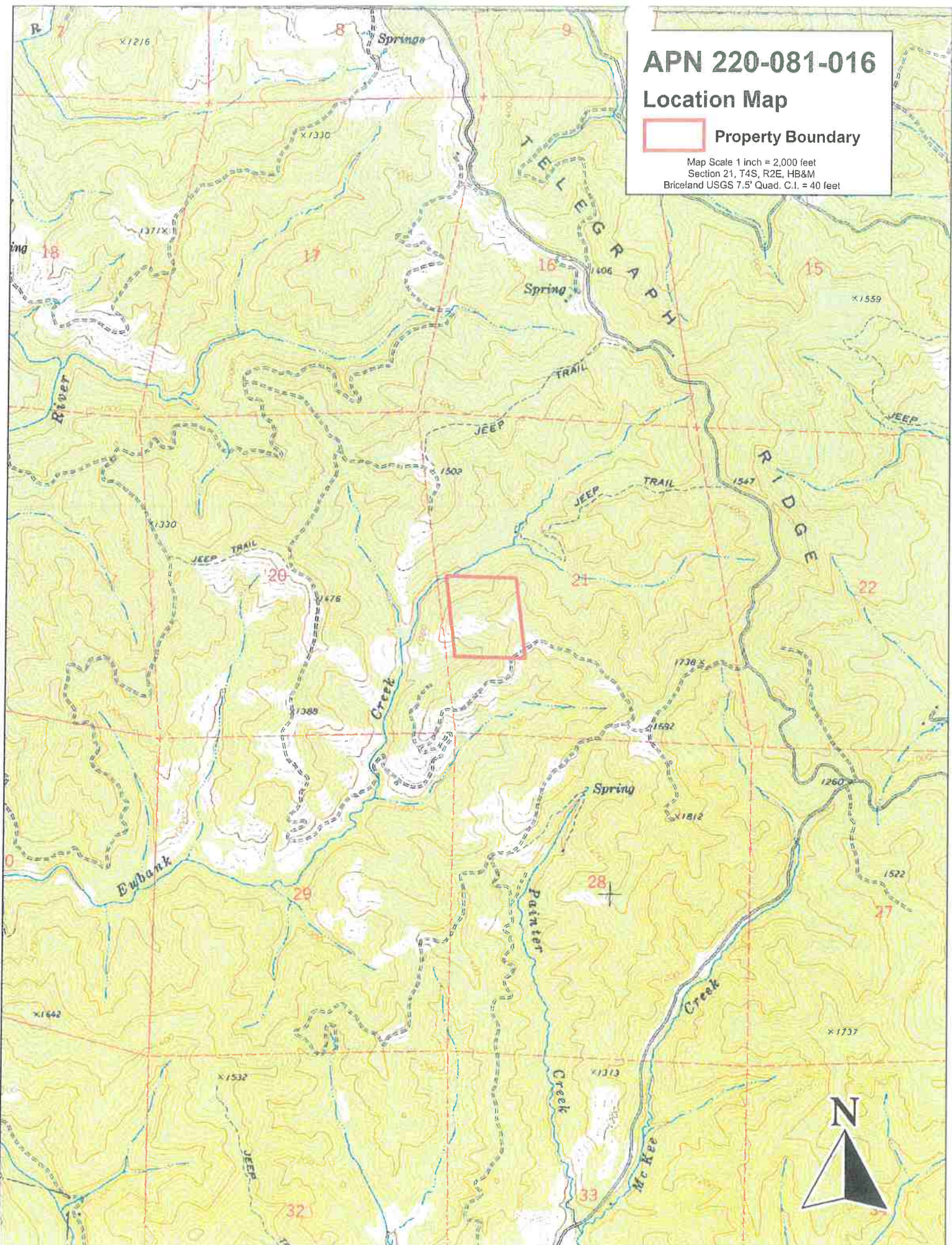

APN 220-081-016

Stormwater Management Plan Map

Map Scale 1 inch = 200 feet
 Section 21, T4S, R2E, HB&M
 Briceland USGS 7.5' Quad, C.1, = 40 feet



- | | | | | | |
|---|--------------------|---|-----------------------------|---|--|
|  | Property Boundary |  | Other Structure |  | Bank Seep / Spring |
|  | Point of Diversion |  | Residence |  | Class III Watercourse |
|  | Tank Farm |  | Agricultural Greenhouse |  | Class II Watercourse |
|  | Water Tank |  | Outdoor Agricultural Garden |  | Seasonal Dirt Road |
|  | Groundwater Well | | |  | Permanent Rock Road |
| | | | |  | Map Points
(E) DRC = Existing Ditch
Relief Culvert |
| | | | |  | Potential Connected Road /
Development Drainage |

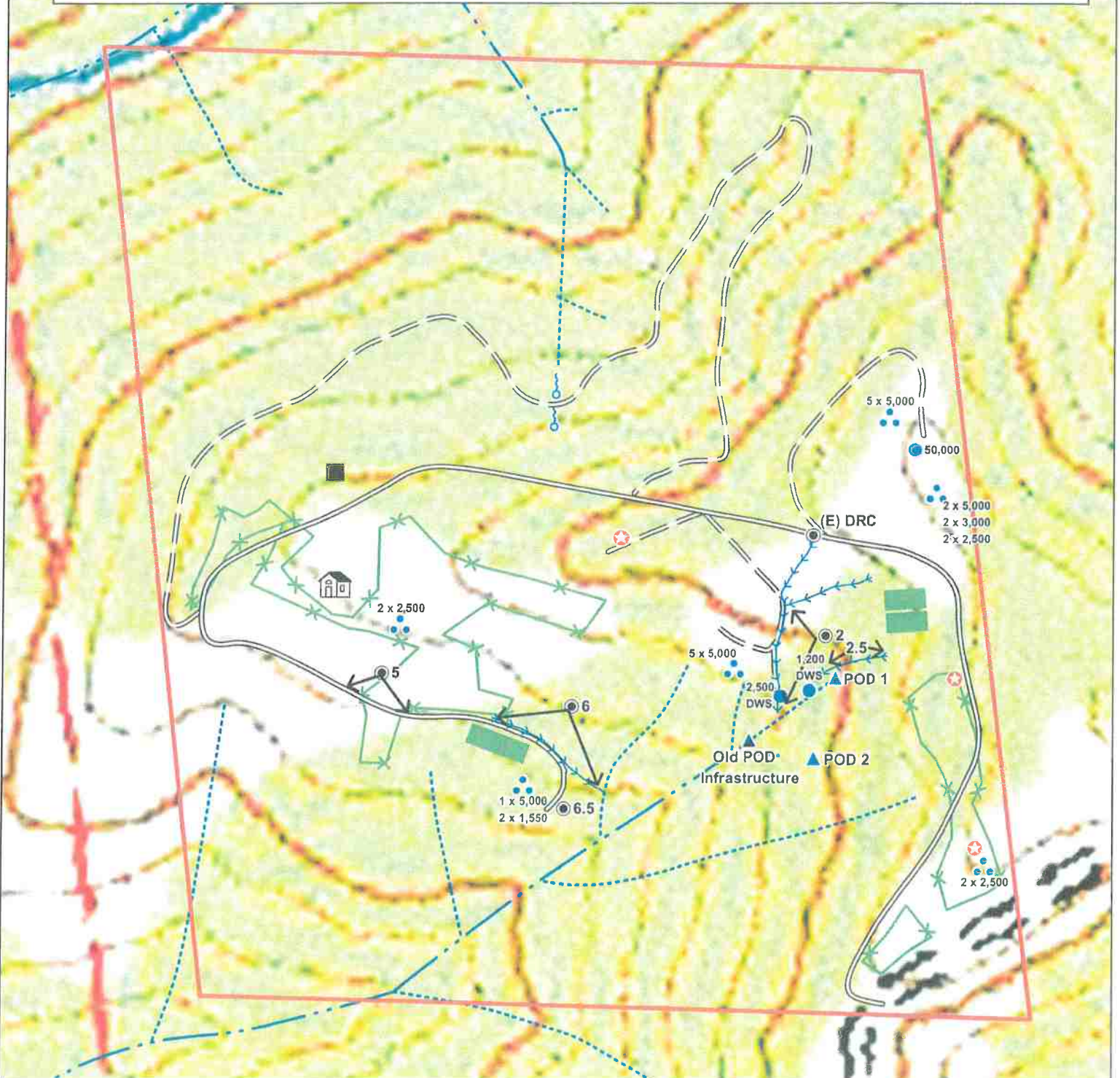

APN 220-081-016

Stormwater Management Plan Map

Map Scale 1 inch = 200 feet
 Section 21, T4S, R2E, HB&M
 Briceland USGS 7.5' Quad C.I. = 40 feet



- | | | | | | |
|---|--------------------|---|-----------------------------|---|--|
|  | Property Boundary |  | Other Structure |  | Bank Seep / Spring |
|  | Point of Diversion |  | Residence |  | Class III Watercourse |
|  | Tank Farm |  | Agricultural Greenhouse |  | Class II Watercourse |
|  | Water Tank |  | Outdoor Agricultural Garden |  | Seasonal Dirt Road |
|  | Groundwater Well | | |  | Permanent Rock Road |
| | | | |  | Map Points
(E) DRC = Existing Ditch
Relief Culvert |
| | | | |  | Potential Connected Road /
Development Drainage |

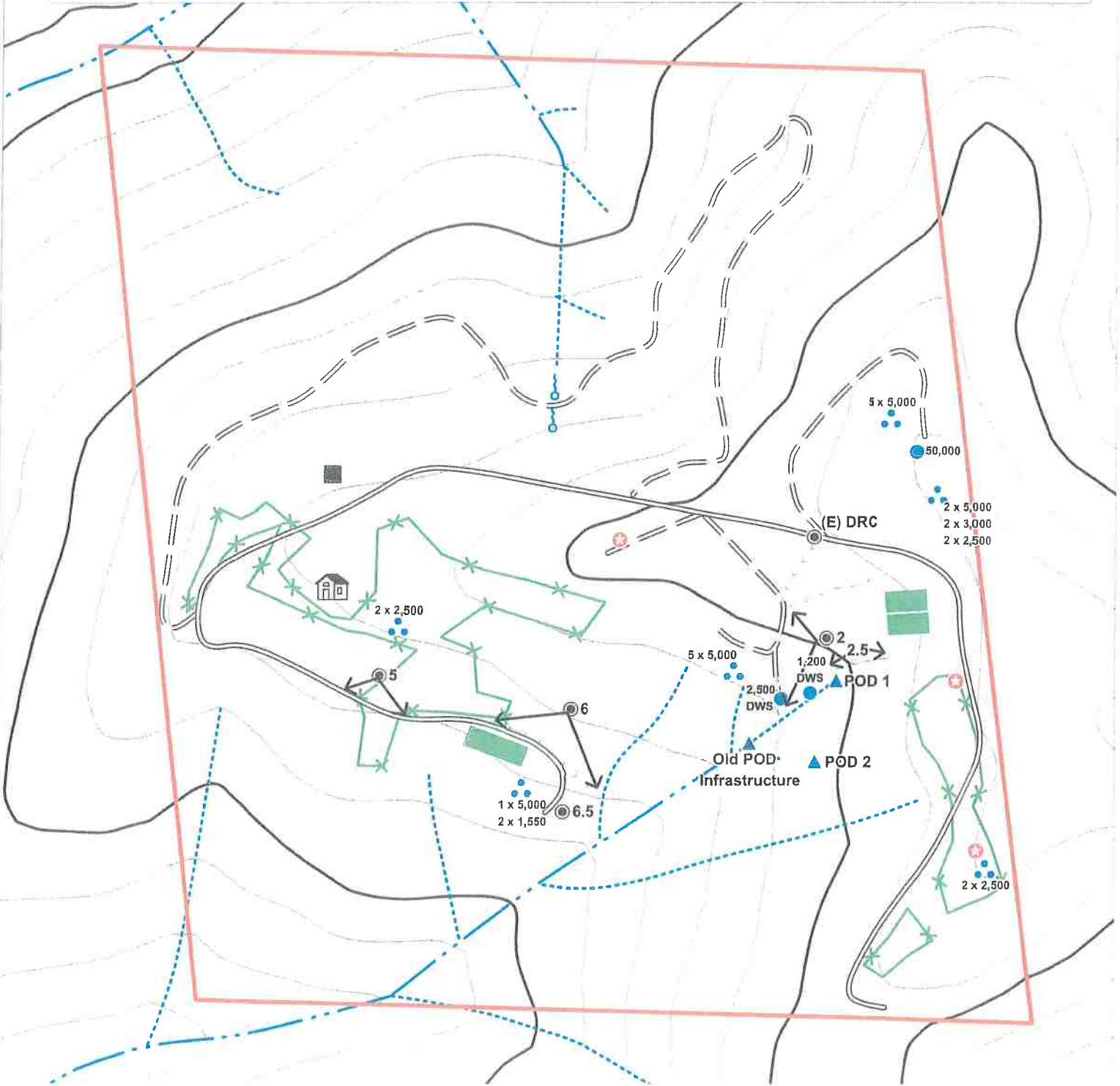

APN 220-081-016

Map Scale 1 inch = 200 feet
 Section 21, T4S, R2E, HB&M
 Briceland USGS 7.5' Quad, C.1, = 40 feet



Stormwater Management Plan Map

- | | | | | | |
|---|--------------------|---|-----------------------------|---|--|
|  | Property Boundary |  | Other Structure |  | Bank Seep / Spring |
|  | Point of Diversion |  | Residence |  | Class III Watercourse |
|  | Tank Farm |  | Agricultural Greenhouse |  | Class II Watercourse |
|  | Water Tank |  | Outdoor Agricultural Garden |  | Seasonal Dirt Road |
|  | Groundwater Well | | |  | Permanent Rock Road |
| | | | |  | Map Points
(E) DRC = Existing Ditch
Relief Culvert |
| | | | |  | Potential Connected Road /
Development Drainage |



LINDBERG GEOLOGIC CONSULTING

David N. Lindberg, CEG
Post Office Box 306
Cuttan California 95534
(707) 442-6000



April 12, 2022

Project No: 0445.00

Lost Coast Elixirs, LLC
Mr. Thomas Harwood
Post Office Box 610
Redway, California 95560

Subject: Hydrologic Isolation of Existing Well from Surface Waters
569 Eubanks Road, Whitethorn, APN: 220-081-016, WCR2021-11658

To Whom It May Concern:

As requested, Lindberg Geologic Consulting has assessed an existing permitted well on the above-referenced parcel to estimate its potential for hydrologic connectivity with any adjacent wetlands and or surface waters, and if pumping this well could affect surface waters in nearby water courses. Creeks in the vicinity of this well drain to the Mattole River (Figure 1). A California-Certified Engineering Geologist visited this site on March 16, 2022 to observe the subject well and local conditions. Based on our professional experience, observations, and research, it is our opinion the subject well has a low likelihood of being hydrologically connected to nearby surface waters in any manner that could affect adjacent wetlands and or surface waters in the vicinity. The client plans to use the water to irrigate cannabis. We are not aware of the volume of water to be extracted or what the pumping schedule might be but expect that the client can supply that information.

This well was drilled by Vic's Well Drilling Inc. of Acton, California, in July, 2021, under county permit #20/21-0663. Vic's Well Drilling is a licensed well-drilling contractor (C-57 #886439). Vic's Well Drilling submitted the well completion report (DWR 188) on September 13, 2021 (attached). Vic's Well Drilling estimated the yield of this well at 12 gallons per minute on July 15, 2021. Based on a four-hour air lift pump test, the total drawdown was reported to be zero (0) feet. The well location is shown approximately on Figures 1 and 3.

Borehole diameter is specified as 8.75-inches in the driller's report. Reported drilled depth is 260 feet. A bentonite surface sanitary seal was installed from grade to 21 feet below the ground surface (bgs). From the surface to the total depth, the well was constructed of 4.5-inch diameter, PVC pipe, and from 21 feet bgs to the total completed total depth of 260 feet bgs, the annulus was backfilled with #6 silica sand. The well is cased and sealed through any potential shallow subsurface aquifers and is screened (0.032" slots) from 140 to 240 feet. Depth to first water was reported as 140 feet below grade, and depth to static water in the completed and developed well was reported to be 132 feet bgs when the driller conducted the pump test on July 15, 2021.

Parcel 220-081-016 (Figure 2) encompasses approximately 40 acres. Based on our on-site GPS measurements, the subject well is located approximately at latitude 40.09703° north, and longitude 123.96557° west (±13'). According to the driller's report, this well is in Section 21, T4S, R2E,

LINDBERG GEOLOGIC CONSULTING
(707) 442-6000

April 12, 2022

Project No: 0445.00

Page 2

HB&M (Figures 1 and 2). Based on the Humboldt County WebGIS mapping, this well is approximately 830 feet south-southwest of Eubank Creek, the nearest mapped watercourse. Based on interpolation from the USGS Briceland topographic quadrangle map (Figure 1), and the Humboldt County WebGIS, well elevation is approximately 1,440 feet above sea level. Elevation of Eubank Creek at the nearest point to the well is approximately 1,060 feet. The elevation of the bottom of the well is approximately 1,180 feet which is approximately 120 feet higher than Eubank Creek at its nearest point.

On the geologic map (Figure 4) this area is underlain by intact sandstone and argillite (co4). These materials were described by McLaughlin and Others (2000) as "intact sandstone and argillite". The unit is described as exhibiting "sharp crested topography with a regular, well-incised system of sidehill drainage".

Materials reported on the geologic log of the driller's well completion report include five feet of "Soil or organic" over 30 feet of "Sand" ("sandstone brown dry"). From the depth of 35 to 95 feet, the driller logged "Claystone" (blueshale stone) which was underlain by 60 feet of "Clayey Gravel" (blue shale stone clay with basalt). From the base of the clayey gravel at 155 feet, to the total depth at 260 feet, 105 feet of "Rock" was logged. The driller further described the 105 feet of "Rock" as "basalt water bearing".

Below the five feet of (soil or organic) topsoil, the earth materials encountered in the boring are likely co4 deposits. Intact sandstone and argillite materials may be expected to have a moderate hydraulic conductivity and should not constitute a significant aquitard. We interpret the underlying sequence of materials described by the driller (sand, claystone, clayey gravel, and rock), as lithologies within the co4 unit of the Coastal Belt of the Franciscan formation. The sandstone is expected to have a higher hydraulic conductivity than the claystone and clayey gravel sections, making the rock (basalt) the water bearing unit in this well.

A geologic cross section of the area after McLaughlin and Others (2000) shows the structural and stratigraphic relationships between the local geologic units (Figure 5). The intact sandstone and argillite (co4) unit is shown schematically as isoclinally folded, and bounded by steeply dipping, near vertical faults. On-site, no dipping of the rock units could be observed in the co4 because it was covered with soil. We interpret the faults to be hydrologic boundaries of minimal permeability (due to grinding and shearing along the fault plane) which effectively separate portions of the co4 from the co1 and co3 and limit groundwater flow between these fault-bound units.

In our professional opinion, based on our experience, observations, and review of pertinent and available information, this well has a low potential of having any direct connection to surface waters. This well is sealed through the upper 21 feet of any potential unconfined, near-surface aquifers with which it could communicate hydraulically through the borehole because the bentonite-sealed surface casing isolates the topsoil and dry sandstone materials from the deep c04 intact sandstone (called basalt by the driller) aquifer. When considered with the stratigraphy and

LINDBERG GEOLOGIC CONSULTING
(707) 442-6000

April 12, 2022

Project No: 0445.00

Page 3

geologic structure, distances (horizontal and vertically) from the nearest surface waters, depth of the producing zone of this well (~155 feet, in rock), and its position relative to the nearest adjacent watercourse (Eubank Creek), we concluded that the depth of the surface seal is sufficient to preclude the potential for hydraulic connectivity with surface waters, of which there are none on the steep hillside. Thus, the water source from which this well draws appears to be a subsurface aquifer not connected to an unconfined, near-surface aquifer. Therefore, this well does not appear likely to be hydraulically connected to nearby wells, surface waters, or wetlands.

In our professional opinion, it appears that the aquifer tapped by the subject well is recharged by water infiltrating from source areas proximal to the well site. As noted, the "Water Level and Yield of Completed Well" section of the Well Completion Report estimated the yield of this well at 12 gallons per minute (gpm) on July 15, 2021, with zero (0) feet of drawdown, after a four-hour air-lift pump test. As noted on the well completion report, this capacity may not be representative of this well's long-term yield. In separate correspondence, the driller recommended that this well be pumped at six gallons per minute.

As discussed, in our opinion the subject well does not appear to be hydrologically connected to, or capable of influencing surface water flows in the nearest tributary of the Mattole River (Eubank Creek), or ephemeral wetlands. Given the horizontal distances involved, and the elevation differences between the water-producing zone in the subject well, and the surface waters of the nearest watercourse, the potential for hydrologic connectivity between surface waters and groundwater in the deep bedrock aquifer appears negligible. Further, given the apparently limiting condition of 120 feet of presumably low-transmissivity "Claystone", and "Clayey Gravel", the deeper, "Rock" zone is the water-producing unit, and is considered hydrologically isolated from, and not connected to any other aquifer(s) in the surrounding, slope mantling colluvial soil, or other sections of the co4 deposits.

On the Briceland USGS topographic quadrangle map, the nearest mapped spring is shown approximately one-half mile to the south in Section 28 (Figure 1) on parcel 220-082-020, at the head of Painter Creek. This spring is the closest mapped spring to the subject well and is at an elevation greater than 1,240 feet. There does not appear to be any other mapped or unmapped wetlands within 1,000 feet of the subject well.

The client informed us that there are other wells on the subject parcel which are used exclusively for domestic purposes. There is one 140-foot-deep (#1087868) well, one 200-foot-deep well (#1087869), and one 120-foot-deep well (#1087870). These domestic wells were drilled in October 2016 by Bushell Enterprises (C-57 license #403708); the driller did not record the locations on the parcel in the DWR Driller's Report of Well Completion. It seems likely that there are domestic and or irrigation wells on adjacent parcels, however, we could find no other wells in the DWR database within 1,000 feet of the subject well.

LINDBERG GEOLOGIC CONSULTING
(707) 442-6000

April 12, 2022

Project No: 0445.00

Page 4

The Natural Resources Conservation Service, Web Soil Survey, shows the subject well to be located within the Canoecreek-Sproulis-Redwohly soil complex, which is described as well-drained. The Web Soil Survey Unit description is attached to this report. Mean annual precipitation in the area is listed as 59 to 100 inches per year. Capacity of the most limiting layer to transmit water (Ksat) is described as moderately low to high (0.14 to 2.00 in/hr). If ten percent of precipitation is absorbed by the soils and does not flow across the surface to local watercourses, then approximately 19.7 acre-feet, or 6.4 million gallons, of water per year may be expected to recharge the local aquifer below the 40 acre subject property.

Based on our professional experience, observations, and research, it is our opinion the well at 569 Eubanks Road has a negligible likelihood of being hydrologically connected to nearby surface waters or wells in any manner that might affect adjacent wetlands and or surface waters in the vicinity.

Please contact us if you have questions or concerns regarding our findings and conclusions.

Sincerely,

David N. Lindberg, CEG
Lindberg Geologic Consulting

DNL:sll

Attachments:

- Figure 1: Topographic Map of Well Location
- Figure 2: Humboldt County Assessor's Parcel Map
- Figure 3: Satellite Image Site Plan
- Figure 4: Geologic Map
- Figure 4a: Geologic Map Explanation
- Figure 5: Geologic Cross Section

State of California Well Completion Reports:

- WCR-2021-0110663 (DWR 188 REV. 12/19/2017), the subject well.
- WCR-1087868, a 140-foot domestic well.
- WCR-1087869, a 200-foot domestic well.
- WCR-1087870, a 120-foot domestic well.

Web Soil Survey, NRCS Unit Description: Canoecreek-Sproulis-Redwohly complex, 50 to 75 percent slopes, warm.

Lindberg Geologic Consulting	Engineering-Geologic Hydrogeologic Well Isolation Report	Figure 1
Post Office Box 306	569 Eubanks Road, Whitethorn, Humboldt County	April 12, 2022
Cutten, CA 95534	APN 220-081-016, Lost Coast Elixirs LLC, Thomas Harwood, Client	Project 0445.00
(707) 442-6000	Topographic Map of the Well Location (all locations approximate)	1" = 2,700'

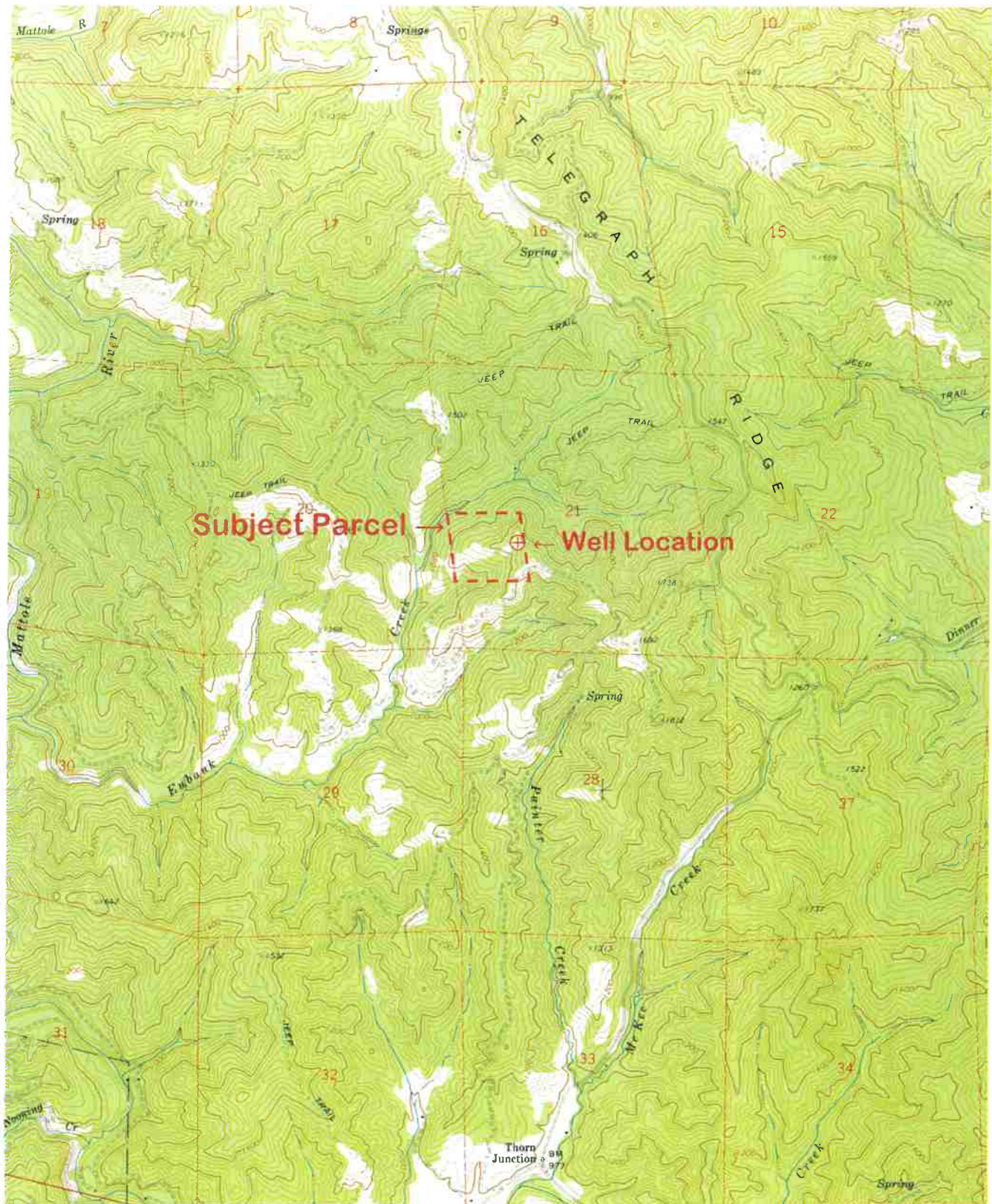

Modified from: USGS "Briceland, Calif." 7.5' Topographic Quadrangle Map, 1969. N \approx 

Lindberg Geologic Consulting	Engineering-Geologic Hydrogeologic Well Isolation Report	Figure 2
Post Office Box 306	569 Eubanks Road, Whitethorn, Humboldt County	April 12, 2022
Cutten, CA 95534	APN 220-081-016, Lost Coast Elixirs LLC, Thomas Harwood, Client	Project 0445.00
(707) 442-6000	Humboldt County Assessor's Parcel Map	Scale as Shown

SECS 21 & 28 T4S, R2E H.B.& M.

220-08

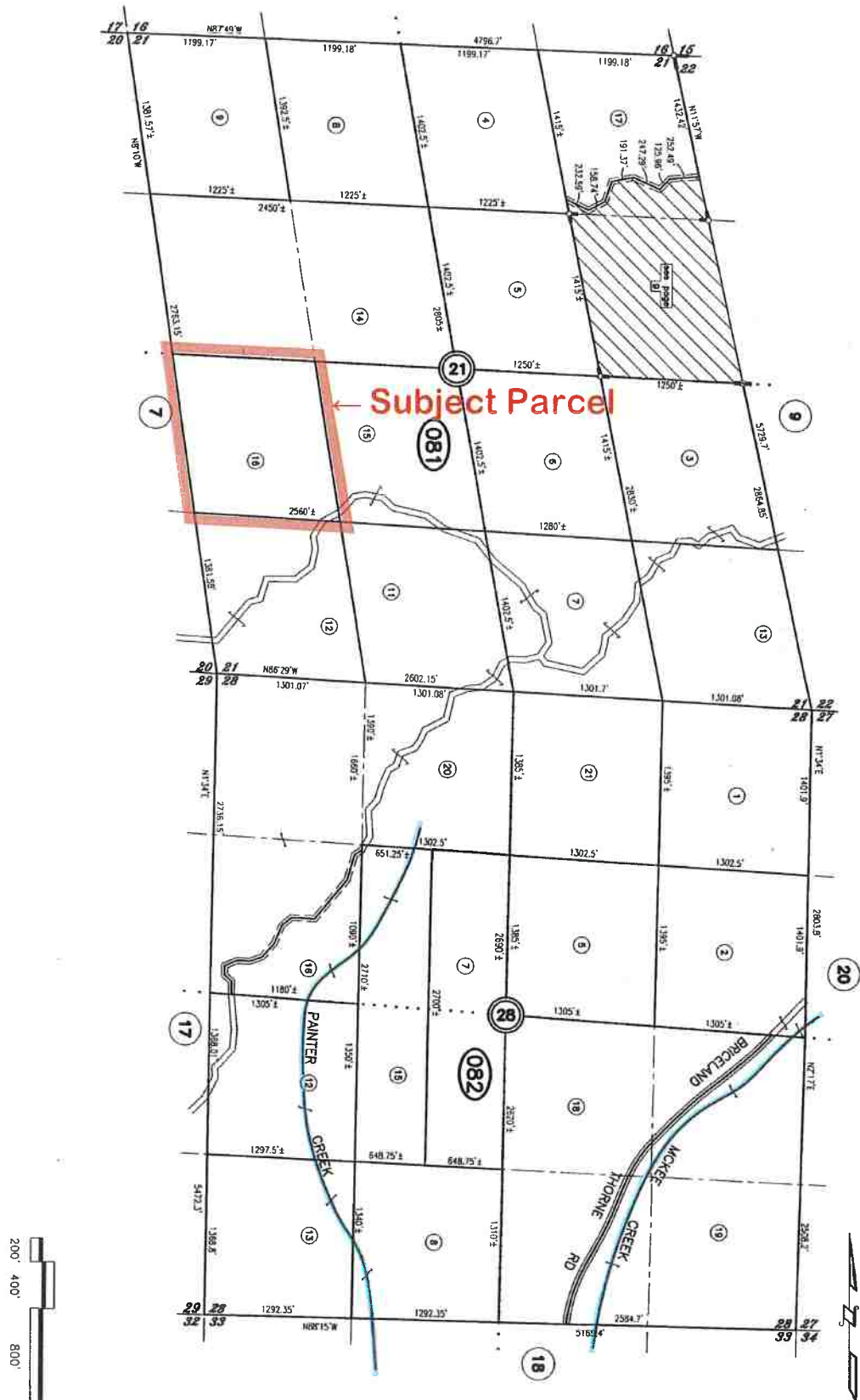

Lindberg Geologic Consulting	Engineering-Geologic Hydrogeologic Well Isolation Report	Figure 3
Post Office Box 306	569 Eubanks Road, Whitethorn, Humboldt County	April 12, 2022
Cutten, CA 95534	APN 220-081-016, Lost Coast Elixirs LLC, Thomas Harwood, Client	Project 0445.00
(707) 442-6000	Satellite Image Site Plan (all locations approximate)	1" \approx 370'

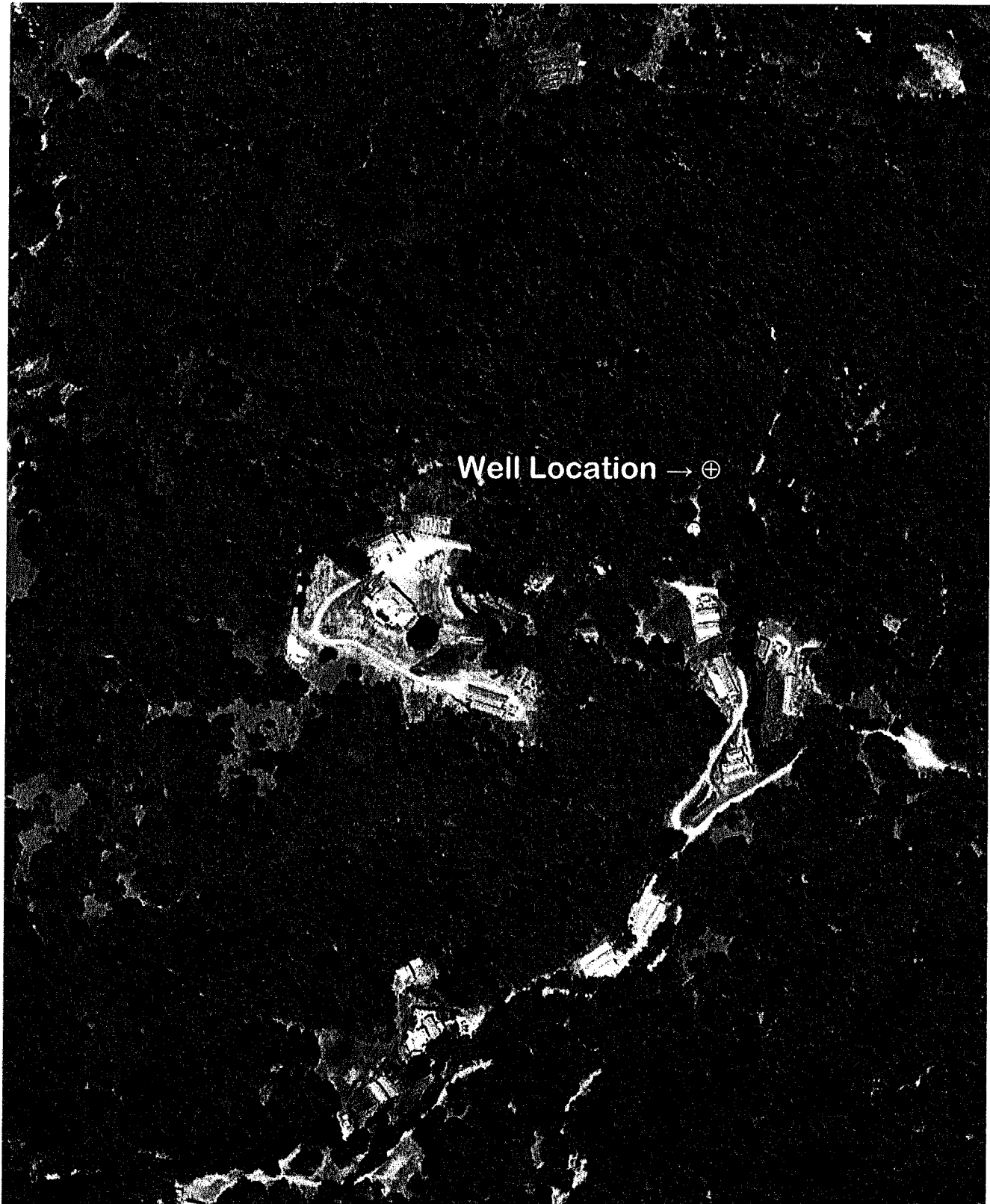

Lindberg Geologic Consulting	Engineering-Geologic Hydrogeologic Well Isolation Report	Figure 4
Post Office Box 306	569 Eubanks Road, Whitethorn, Humboldt County	April 12, 2022
Cutten, CA 95534	APN 220-081-016, Lost Coast Elixirs LLC, Thomas Harwood, Client	Project 0445.00
(707) 442-6000	Geologic Map (all locations approximate)	1" ≈ 4,550'

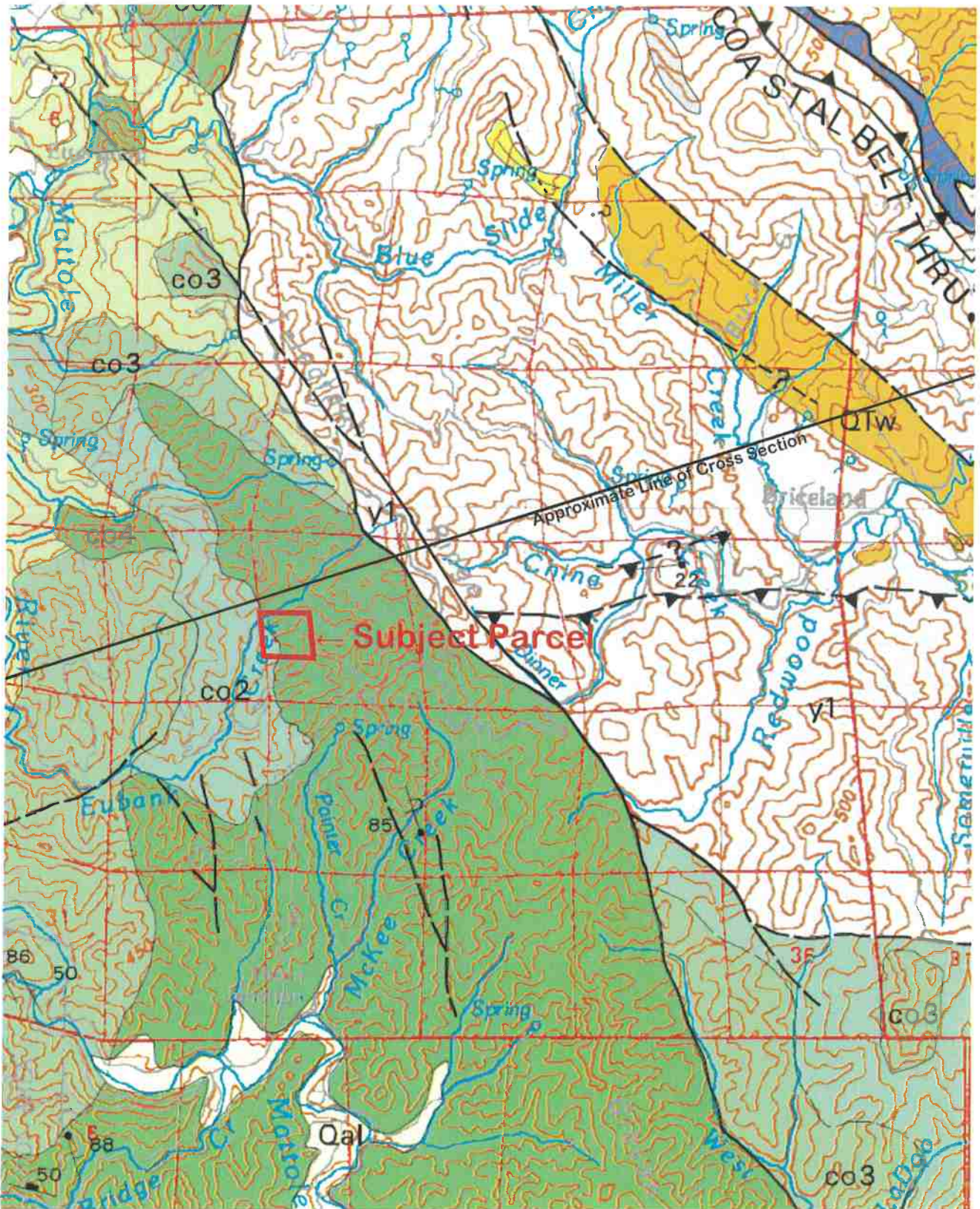

Modified from: McLaughlin and Others, 2000. N ≈

DESCRIPTION OF MAP UNITS

QUATERNARY AND TERTIARY OVERLAP DEPOSITS

Qal	Alluvial deposits (Holocene and late Pleistocene?)
Qm	Undeformed marine shoreline and aeolian deposits (Holocene and late Pleistocene)
Qt	Undifferentiated nonmarine terrace deposits (Holocene and Pleistocene)
Qls	Landslide deposits (Holocene and Pleistocene)
QTog	Older alluvium (Pleistocene and/or Pliocene)
QTw	Marine and nonmarine overlap deposits (late Pleistocene to middle Miocene)
Tt	Volcanic rocks of Fiddle Hill (Oligocene)

COAST RANGES PROVINCE
FRANCISCAN COMPLEX

— Coastal Belt —

Coastal terrane (Pliocene to Late Cretaceous)

Sedimentary, igneous, and metamorphic rocks of the Coastal terrane (Pliocene to Late Cretaceous):

co1	Melange
co2	Melange
co3	Broken sandstone and argillite
co4	Intact sandstone and argillite
cab	Basaltic Rocks (Late Cretaceous)
cols	Limestone (Late Cretaceous)
m	Undivided blueschist (Jurassic?)

King Range terrane (Miocene to Late Cretaceous)

Krp	Igneous and sedimentary rocks of Point Delgada (Late Cretaceous)
m	Undivided blueschist blocks (Jurassic?)
krk1	Melange and/or folded argillite
krk2	Highly folded broken formation
krk3	Highly folded, largely unbroken rocks
krf	Limestone
krc	Chert
krb	Basalt

False Cape terrane (Miocene? to Oligocene?)

fc	Sedimentary rocks of the False Cape terrane (Miocene? to Oligocene?)
----	--

Yager terrane (Eocene to Paleocene?)

Sedimentary rocks of the Yager terrane (Eocene to Paleocene?):

y1	Sheared and highly folded mudstone
y2	Highly folded broken mudstone, sandstone, and conglomeratic sandstone
y3	Highly folded, little-broken sandstone, conglomerate, and mudstone
Ycgl	Conglomerate

— Central belt —

Melange of the Central belt (early Tertiary to Late Cretaceous):

cm1	Melange
cm2	Melange
cb1	Broken formation
cb2	Broken formation
cwr	White Rock metasediment of Jayko and others (1989) (Paleogene and/or Late Cretaceous)
ch:	Haman Ridge graywacke of Jayko and others (1989) (Cretaceous?)
cfs	Fort Seward metasediment (age unknown)
cls	Limestone (Late to Early Cretaceous)

cc	Chert (Late Cretaceous to Early Jurassic)
bs	Basaltic rocks (Cretaceous and Jurassic)
m	Undivided blueschist blocks (Jurassic?)
gs	Greenstone
c	Metachert
yb	Metasandstone of Yolla Bolly terrane, undivided
b	Melange block, lithology unknown:

— Eastern Belt —

Pickett Peak terrane (Early Cretaceous or older)

Metasedimentary and metavolcanic rocks of the Pickett Peak terrane (Early Cretaceous or older):

ppsm	South Fork Mountain Schist
mb	Chinquapin metabasalt Member (Irwin and others, 1974)
ppv	Valentine Springs Formation
mv	Metabasalt and minor metachert

Yolla Bolly terrane (Early Cretaceous to Middle Jurassic?)

Metasedimentary and metigneous rocks of the Yolla Bolly terrane (Early Cretaceous to Middle Jurassic?):

ybt	Tallaferro Metamorphic Complex of Suppe and Armstrong (1972) (Early Cretaceous to Middle Jurassic?)
ybc	Chicago Rock melange of Blake and Jayko (1983) (Early Cretaceous to Middle Jurassic)
gs	Greenstone
c	Metachert
ybh	Metagraywacke of Hammerhorn Ridge (Late Jurassic to Middle Jurassic)
c	Metachert
gs	Greenstone
sp	Serpentinite
ybd	Devils Hole Ridge broken formation of Blake and Jayko (1983) (Early Cretaceous to Middle Jurassic)
c	Radiolarian chert
ybi	Little Indian Valley argillite of McLaughlin and Ohlin (1984) (Early Cretaceous to Late Jurassic)

Yolla Bolly terrane

Rocks of the Yolla Bolly terrane, undivided

GREAT VALLEY SEQUENCE AND COAST RANGE OPHIOLITE

Elder Creek(?) terrane

ecms	Mudstone (Early Cretaceous)
ecg	Coast Range ophiolite (Middle and Late Jurassic)
ecsp	Layered gabbro
ecsp	Serpentinite melange

Del Puerto(?) terrane

dpms	Rocks of the Del Puerto(?) terrane: Mudstone (Late Jurassic)
dpms	Coast Range ophiolite (Middle and Late Jurassic)
dpt	Tuffaceous chert (Late Jurassic)
dpb	Basaltic flows and keratophytic tuff (Jurassic?)
dpc	Diabase (Jurassic?)
dpsp	Serpentinite melange (Jurassic?)
sp	Undivided Serpentinized peridotite (Jurassic?)

KLAMATH MOUNTAINS PROVINCE

Ks	Undivided Great Valley Sequence: Sedimentary rocks (Lower Cretaceous)
----	---

GREAT VALLEY SEQUENCE OVERLAP ASSEMBLAGE

Hayfork terrane

eh	Eastern Hayfork subterrane: Melange and broken formation (early? Middle Jurassic)
ehls	Limestone
ehsp	Serpentinite
whu	Western Hayfork subterrane: Hayfork Bally Meta-andesite of Irwin (1985), undivided (Middle Jurassic)
wfwg	Wildwood (Chancelulla Peak of Wright and Fahar, 1988) pluton (Middle Jurassic)
whwp	Clinopyroxenite
wyj	Diorite and gabbro plutons (Middle? Jurassic)

Butterfame Creek terrane

rcm	Melange (Jurassic and older)
rcs	Limestone
rcc	Radiolarian chert
rcs	Volcanic Rocks (Jurassic or Triassic)
rcic	Intrusive complex (Early Jurassic or Late Triassic)
rcp	Plutonic rocks (Early Jurassic or Late Triassic)
rcum	Ultramafic rocks (age uncertain)
rcpd	Blocky peridotite

Western Klamath terrane

srs	Smith River subterrane: Galice? formation (Late Jurassic)
srv	Pyroclastic andesite
srgb	Glen Creek gabbro-ultramafic complex of Irwin and others (1974)
srpd	Serpentinized peridotite

MAP SYMBOLS

— — — — —	Contact
— — — — —	Fault
— — — — —	Thrust fault
— — — — —	Trace of the San Andreas fault associated with 1906 earthquake rupture
— — — — —	Strike and dip of bedding:
10 20	Inclined
10 20	Vertical
10 20	Horizontal
10 20	Overturned
10 20	Approximate
10 20	Joint
10 20	Strike and dip of cleavage
10 20	Shear foliation:
10 20	Inclined
10 20	Vertical
10 20	Folds:
10 20	Synclinal or antiformal axis
10 20	Anticlinal or antiformal axis
10 20	Overturned syncline
10 20	Landslide
10 20	Melange blocks:
10 20	Serpentinite
10 20	Chert
10 20	Blueschist
10 20	Greenstone
10 20	Fossil locality and number

Lindberg Geologic Consulting	Engineering-Geologic Hydrogeologic Well Isolation Report	Figure 5
Post Office Box 306	569 Eubanks Road, Whitethorn, Humboldt County	April 12, 2022
Cutten, CA 95534	APN 220-081-016, Lost Coast Elixirs LLC, Thomas Harwood, Client	Project 0445.00
(707) 442-6000	Geologic Cross Section (all locations approximate)	Not to Scale

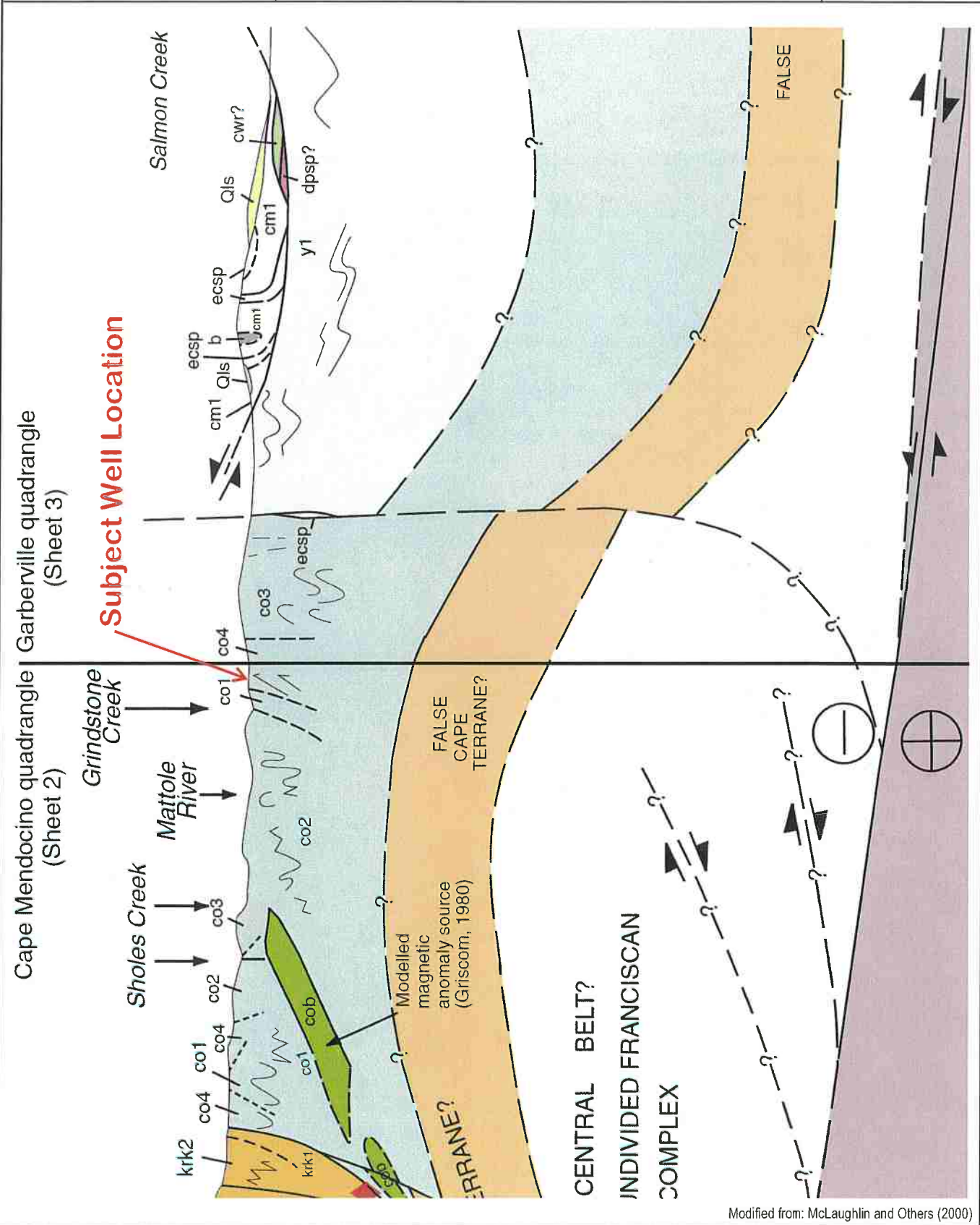

Modified from: McLaughlin and Others (2000)

State of California
Well Completion Report
 Form DWR 188 Submitted 9/13/2021
 WCR2021-011658

Owner's Well Number 2 Date Work Began 07/13/2021 Date Work Ended 07/15/2021
 Local Permit Agency Humboldt County Department of Health & Human Services - Land Use Program
 Secondary Permit Agency _____ Permit Number 20/21-0663 Permit Date 02/11/2021

Well Owner (must remain confidential pursuant to Water Code 13752)	Planned Use and Activity
Name <u>TOMMY HARWOOD</u>	Activity <u>New Well</u>
Mailing Address <u>569 EUBANKS RD.</u>	Planned Use <u>Water Supply Irrigation - Agriculture</u>
City <u>WHITETHORN</u> State <u>CA</u> Zip <u>95579</u>	

Well Location	
Address <u>569 EUBANKS RD</u>	APN _____
City <u>WHITETHORN</u> Zip <u>95579</u> County <u>Humboldt</u>	Township <u>04 S</u>
Latitude <u>40 5 49.7209 N</u> Longitude <u>-123 57 56.165 W</u>	Range <u>02 E</u>
Deg. Min. Sec. Deg. Min. Sec.	Section <u>21</u>
Dec. Lat. <u>40.0971447</u> Dec. Long. <u>-123.9656014</u>	Baseline Meridian <u>Humboldt</u>
Vertical Datum _____ Horizontal Datum <u>WGS84</u>	Ground Surface Elevation <u>1350</u>
Location Accuracy _____ Location Determination Method _____	Elevation Accuracy <u>10 Ft</u>
	Elevation Determination Method <u>GPS</u>

Borehole Information	Water Level and Yield of Completed Well
Orientation <u>Vertical</u> Specify _____	Depth to first water <u>140</u> (Feet below surface)
Drilling Method <u>Downhole Rotary Hammer</u> Drilling Fluid <u>Air</u>	Depth to Static _____
Total Depth of Boring <u>260</u> Feet	Water Level <u>132</u> (Feet) Date Measured <u>07/15/2021</u>
Total Depth of Completed Well <u>260</u> Feet	Estimated Yield* <u>12</u> (GPM) Test Type <u>Air Lift</u>
	Test Length <u>4</u> (Hours) Total Drawdown <u>0</u> (feet)
	*May not be representative of a well's long term yield.

Geologic Log - Lite					
Depth from Surface	Feet to Feet	Material Type	Material Color	Material Texture	Material Description
0	5	Soil or Organic	Brown	Organic	TOP SOIL BROWN
5	35	Sand	Brown	Coarse	SANDSTONE BROWN DRY
35	95	Claystone	Blue	Clayey	BLUESHALE STONE
95	155	Clayey Gravel	Blue	Clayey	BLUE SHALE STONE CLAY WITH BASALT
155	260	Rock	Blue	Hard	BASALT WATER BEARING

Casings										
Casing #	Depth from Surface Feet to Feet		Casing Type	Material	Casings Specifications	Wall Thickness (inches)	Outside Diameter (inches)	Screen Type	Slot Size if any (inches)	Description
1	0	140	Blank	PVC	OD: 4.500 in. Thickness: 0.337 in.	0.337	4.5			
1	140	240	Screen	PVC	OD: 4.500 in. Thickness: 0.337 in.	0.337	4.5	Milled Slots	32	.032
1	240	260	Blank	PVC	OD: 4.500 in. Thickness: 0.337 in.	0.337	4.5			/4" CAP INSTALLED

Annular Material					
Depth from Surface Feet to Feet		Fill	Fill Type Details	Filter Pack Size	Description
0	21	Bentonite	Other Bentonite	3/8" CHIPS DUMPED FROM SURFACE WHILE ADDING WATER	18 BAGS
21	260	Filter Pack	Other Gravel Pack	#6 SILICA	3 BAGS

Other Observations:

Borehole Specifications		
Depth from Surface Feet to Feet		Borehole Diameter (inches)
0	260	8.75

Certification Statement			
I, the undersigned, certify that this report is complete and accurate to the best of my knowledge and belief			
Name <u>VICS WELL DRILLING INC</u>			
Person, Firm or Corporation			
<u>3807 SIERRA HWY UNIT #6</u>	<u>ACTON</u>	<u>CA</u>	<u>93510</u>
Address	City	State	Zip
Signed <u>electronic signature received</u>	<u>09/13/2021</u>	<u>886439</u>	
C-57 Licensed Water Well Contractor	Date Signed	C-57 License Number	

Attachments
E3902_20210219_083348.pdf - Permit
PLOT PLAN #2 (3).jpg - Other
DRILLERS REPORT.docx - Other

DWR Use Only			
CSG #	State Well Number	Site Code	Local Well Number
		N	W
Latitude Deg/Min/Sec		Longitude Deg/Min/Sec	
TRS:			
APN:			

ORIGINAL
File with DWR

JUN 01 2017

STATE OF CALIFORNIA
WELL COMPLETION REPORT

Refer to Instruction Pamphlet

Page ___ of ___

Owner's Well No. 1

No. **1087868**

Date Work Began Oct 5 2016, Ended Oct 5 2016

Local Permit Agency Humboldt

Permit No. 16/17/0228 Permit Date Sept 29, 16

DWR USE ONLY - DO NOT FILL IN

04S102E+21

STATE WELL NO./STATION NO.

LATITUDE _____ LONGITUDE _____

APN/TRS/OTHER _____

GEOLOGIC LOG

ORIENTATION () VERTICAL HORIZONTAL ANGLE _____ (SPECIFY) _____

DRILLING METHOD Rotary FLUID _____

DEPTH FROM SURFACE _____
Describe material, grain size, color, etc.

Fl.	to	Fl.	DESCRIPTION
0	25		Soft Brn Rock
25	50		Gry Shale
50	80		Hard gry Shale
80	85		Shale w/ Quarts/wtr
85	140		HARD gry Shale

WELL LOCATION

Address 569 EUBANKS RD
City BRICELAND rd ETERSBERG
County HUMB
APN Book _____ Page _____ Parcel 220 081 016
Township _____ Range _____ Section _____
Lat _____ N Long _____ W

LOCATION SKETCH NORTH _____ SOUTH _____ WEST _____ EAST _____

ACTIVITY ()
 NEW WELL
 MODIFICATION/REPAIR
 Deepen
 Other (Specify) _____
 DESTROY (Describe Procedures and Materials Under "GEOLOGIC LOG")

USES ()
WATER SUPPLY
 Domestic Public
 Irrigation Industrial

MONITORING _____
TEST WELL _____
CATHODIC PROTECTION _____
HEAT EXCHANGE _____
DIRECT PUSH _____
INJECTION _____
VAPOR EXTRACTION _____
SPARGING _____
REMEDICATION _____
OTHER (SPECIFY) _____

Illustrate or Describe Distance of Well from Roads, Buildings, Fences, Rivers, etc. and attach a map. Use additional paper if necessary. **PLEASE BE ACCURATE & COMPLETE.**

WATER LEVEL & YIELD OF COMPLETED WELL

DEPTH TO FIRST WATER 110 (Ft.) BELOW SURFACE
DEPTH OF STATIC WATER LEVEL 100 (Ft.) & DATE MEASURED Oct 5 2016
ESTIMATED YIELD 10 (GPM) & TEST TYPE Air Lift
TEST LENGTH 1 (Hrs.) TOTAL DRAWDOWN _____ (Ft.)
** May not be representative of a well's long-term yield.*

TOTAL DEPTH OF BORING 140 (Feet)
TOTAL DEPTH OF COMPLETED WELL 140 (Feet)

DEPTH FROM SURFACE Fl. to Fl.	BORE-HOLE DIA. (Inches)	CASING (S)						DEPTH FROM SURFACE Fl. to Fl.	ANNULAR MATERIAL			
		TYPE ()	MATERIAL / GRADE	INTERNAL DIAMETER (Inches)	GAUGE OR WALL THICKNESS	SLOT SIZE IF ANY (Inches)	CE-MENT ()		BEN-TONITE ()	FILL ()	FILTER PACK (TYPE/SIZE)	
0 to 80	9"	BLANK	F 480	5"	5/16"		0 to 20					
80 to 140	11"	SCREEN	"	"	"	.022"	20 to 140				3/8 Pea	

ATTACHMENTS ()

Geologic Log
 Well Construction Diagram
 Geophysical Log(s)
 Soil/Water Chemical Analyses
 Other _____

ATTACH ADDITIONAL INFORMATION, IF IT EXISTS.

CERTIFICATION STATEMENT

I, the undersigned, certify that this report is complete and accurate to the best of my knowledge and belief.

NAME Bushnell Enterprises
(PERSON, FIRM, OR CORPORATION) (TYPED OR PRINTED)

ADDRESS 649 Beavercreek RD GARD CA 95542 CITY _____ STATE _____ ZIP _____

Signed [Signature] DATE SIGNED 5-24-17 403708
C-57 LICENSED WATER WELL CONTRACTOR C-57 LICENSE NUMBER

ORIGINAL
File with DWR

JUN 01 2017

STATE OF CALIFORNIA
WELL COMPLETION REPORT

Refer to Instruction Pamphlet

Page of
Owner's Well No. 2

No. **1087869**

Date Work Began 10-6-16, Ended 10-6-16

Local Permit Agency Humboldt

Permit No. 16-17-0327 Permit Date Sept 29th 2016

DWR USE ONLY — DO NOT FILL IN

045102E+21

STATE WELL NO./STATION NO.

LATITUDE _____ LONGITUDE _____

APN/TRS/OTHER _____

GEOLOGIC LOG

DEPTH FROM SURFACE			DESCRIPTION
Fl.	to	Fl.	
0	20		Soft Brn Rock
20	65		GrY shale
65	120		GrY shale
120	160		HRD Blue Sand Stone
160	200		GrY shale

WELL OWNER _____

ZIP _____

WELL LOCATION

Address 569 EUBANKS RD

City EDDERSBURG

County Humboldt

APN Book _____ Page _____ Parcel 220 081 016

Township _____ Range _____ Section _____

Lat _____ N Long _____ W

LOCATION SKETCH

WEST _____ EAST _____

_____ NORTH _____ SOUTH _____

ACTIVITY ()

NEW WELL

MODIFICATION/REPAIR

___ Deepen

___ Other (Specify) _____

DESTROY (Describe Procedures and Materials Under "GEOLOGIC LOG")

USES ()

WATER SUPPLY

Domestic ___ Public

___ Irrigation ___ Industrial

MONITORING _____

TEST WELL _____

CATHODIC PROTECTION _____

HEAT EXCHANGE _____

DIRECT PUSH _____

INJECTION _____

VAPOR EXTRACTION _____

SPARGING _____

REMEDATION _____

OTHER (SPECIFY) _____

WATER LEVEL & YIELD OF COMPLETED WELL

DEPTH TO FIRST WATER 200 (Fl.) BELOW SURFACE

DEPTH OF STATIC WATER LEVEL 190 (Fl.) & DATE MEASURED 10-6-16

ESTIMATED YIELD * 15 (GPM) & TEST TYPE AIR LIFT

TEST LENGTH 1 (Hrs.) TOTAL DRAWDOWN _____ (Fl.)

* May not be representative of a well's long-term yield.

TOTAL DEPTH OF BORING 200 (Feet)

TOTAL DEPTH OF COMPLETED WELL 198 (Feet)

DEPTH FROM SURFACE	BORE-HOLE DIA. (Inches)	CASING (S)							DEPTH FROM SURFACE	ANNULAR MATERIAL				
		TYPE ()				MATERIAL / GRADE	INTERNAL DIAMETER (Inches)	GAUGE OR WALL THICKNESS		SLOT SIZE IF ANY (Inches)	TYPE			
		BLANK	SCREEN	CON. DUCTOR	FILL PIPE						CE-MENT ()	BEN-TONITE ()	FILL ()	FILTER PACK (TYPE/SIZE)
0 to 160	9"	<input checked="" type="checkbox"/>	<input checked="" type="checkbox"/>	<input type="checkbox"/>	<input type="checkbox"/>	F480	5"	SCH160			<input checked="" type="checkbox"/>			
160 to 200		<input type="checkbox"/>	<input type="checkbox"/>	<input type="checkbox"/>	<input type="checkbox"/>		5"		.032				3/8 Pca	

ATTACHMENTS ()

___ Geologic Log

___ Well Construction Diagram

___ Geophysical Log(s)

___ Soil/Water Chemical Analyses

___ Other _____

ATTACH ADDITIONAL INFORMATION, IF IT EXISTS

CERTIFICATION STATEMENT

I, the undersigned, certify that this report is complete and accurate to the best of my knowledge and belief.

NAME Bushnell Enterprises
(PERSON, FIRM, OR CORPORATION) (TYPED OR PRINTED)

ADDRESS 649 Bearcreek RD Garb CA 95542 CITY STATE ZIP

Signed [Signature] DATE SIGNED 5-24-17 403708
C-57 LICENSE NUMBER

ORIGINAL
File with DWR

JUN 01 2017

STATE OF CALIFORNIA
WELL COMPLETION REPORT

Refer to Instruction Pamphlet

Page 3 of
Owner's Well No. 3

No. **1087870**

Date Work Began 10-7-16 Ended 10-7-16

Local Permit Agency Humbt

Permit No. 16/17-0329 Permit Date Sept 29-16

DWR USE ONLY - DO NOT FILL IN

049102E-21

STATE WELL NO./STATION NO.

LATITUDE _____ LONGITUDE _____

APN/TRS/OTHER _____

GEOLOGIC LOG

ORIENTATION () VERTICAL HORIZONTAL ANGLE _____ (SPECIFY) _____

DRILLING METHOD Rotary FLUID _____

DEPTH FROM SURFACE		DESCRIPTION
Fl.	to Fl.	
0	20	Soft Brn Rock
20	50	GRY shale
50	80	HRD GRY shale
80	85	GRY shale w Quarts
85	120	GRY shale w Quarts

WELL LOCATION

Address 569 EUBANKS RD
City Ettersburg RD
County HUMB

APN Book _____ Page _____ Parcel 220-051-016
Township _____ Range _____ Section _____
Lat _____ N Long _____ W

LOCATION SKETCH NORTH

WEST EAST

ACTIVITY ()

NEW WELL

MODIFICATION/REPAIR

Deepen

Other (Specify) _____

DESTROY (Describe Procedures and Materials Under "GEOLOGIC LOG")

USES ()

WATER SUPPLY

Domestic Public

Irrigation Industrial

MONITORING _____

TEST WELL _____

CATHODIC PROTECTION _____

HEAT EXCHANGE _____

DIRECT PUSH _____

INJECTION _____

VAPOR EXTRACTION _____

SPARGING _____

REMEDICATION _____

OTHER (SPECIFY) _____

WATER LEVEL & YIELD OF COMPLETED WELL

DEPTH TO FIRST WATER 80 (Fl.) BELOW SURFACE

DEPTH OF STATIC WATER LEVEL 70 (Fl.) & DATE MEASURED 10-7-16

ESTIMATED YIELD 20 (GPM) & TEST TYPE AIR LIFT

TEST LENGTH 1 (Hrs.) TOTAL DRAWDOWN _____ (Fl.)

* May not be representative of a well's long-term yield.

TOTAL DEPTH OF BORING 120 (Feet)

TOTAL DEPTH OF COMPLETED WELL 120 (Feet)

DEPTH FROM SURFACE	BORE-HOLE DIA. (Inches)	CASING (S)						ANNULAR MATERIAL					
		TYPE ()				MATERIAL / GRADE	INTERNAL DIAMETER (Inches)	GAUGE OR WALL THICKNESS	SLOT SIZE IF ANY (Inches)	TYPE			
Fl.	to Fl.	BLANK	SCREEN	CON. DUCTOR	FILL PIPE					CE-MENT ()	BEN-TONITE ()	FILL ()	FILTER PACK (TYPE/SIZE)
0	80	9"	<input checked="" type="checkbox"/>	<input checked="" type="checkbox"/>		F480	5"	5/16" x 1/64"					
80	120							.032					3/8 Pea

ATTACHMENTS ()

Geologic Log

Well Construction Diagram

Geophysical Log(s)

Soil/Water Chemical Analyses

Other _____

ATTACH ADDITIONAL INFORMATION, IF IT EXISTS.

CERTIFICATION STATEMENT

I, the undersigned, certify that this report is complete and accurate to the best of my knowledge and belief.

NAME Bushnell Enterprises

(PERSON, FIRM, OR CORPORATION) (TYPED OR PRINTED)

ADDRESS 1649 Bearcreek rd Garb CA 95542 CITY STATE ZIP

Signed [Signature] DATE SIGNED 5-24-17 403708

CALIFORNIA LICENSED WATER WELL CONTRACTOR

Map Unit Description

The map units delineated on the detailed soil maps in a soil survey represent the soils or miscellaneous areas in the survey area. The map unit descriptions in this report, along with the maps, can be used to determine the composition and properties of a unit.

A map unit delineation on a soil map represents an area dominated by one or more major kinds of soil or miscellaneous areas. A map unit is identified and named according to the taxonomic classification of the dominant soils. Within a taxonomic class there are precisely defined limits for the properties of the soils. On the landscape, however, the soils are natural phenomena, and they have the characteristic variability of all natural phenomena. Thus, the range of some observed properties may extend beyond the limits defined for a taxonomic class. Areas of soils of a single taxonomic class rarely, if ever, can be mapped without including areas of other taxonomic classes. Consequently, every map unit is made up of the soils or miscellaneous areas for which it is named, soils that are similar to the named components, and some minor components that differ in use and management from the major soils.

Most of the soils similar to the major components have properties similar to those of the dominant soil or soils in the map unit, and thus they do not affect use and management. These are called noncontrasting, or similar, components. They may or may not be mentioned in a particular map unit description. Some minor components, however, have properties and behavior characteristics divergent enough to affect use or to require different management. These are called contrasting, or dissimilar, components. They generally are in small areas and could not be mapped separately because of the scale used. Some small areas of strongly contrasting soils or miscellaneous areas are identified by a special symbol on the maps. If included in the database for a given area, the contrasting minor components are identified in the map unit descriptions along with some characteristics of each. A few areas of minor components may not have been observed, and consequently they are not mentioned in the descriptions, especially where the pattern was so complex that it was impractical to make enough observations to identify all the soils and miscellaneous areas on the landscape.

The presence of minor components in a map unit in no way diminishes the usefulness or accuracy of the data. The objective of mapping is not to delineate pure taxonomic classes but rather to separate the landscape into landforms or landform segments that have similar use and management requirements. The delineation of such segments on the map provides sufficient information for the development of resource plans. If intensive use of small areas is planned, however, onsite investigation is needed to define and locate the soils and miscellaneous areas.

An identifying symbol precedes the map unit name in the map unit descriptions. Each description includes general facts about the unit and gives important soil properties and qualities.

Soils that have profiles that are almost alike make up a *soil series*. All the soils of a series have major horizons that are similar in composition, thickness, and arrangement. Soils of a given series can differ in texture of the surface layer, slope, stoniness, salinity, degree of erosion, and other characteristics that affect their use. On the basis of such differences, a soil series is divided into *soil phases*. Most of the areas shown on the detailed soil maps are phases of soil series. The name of a soil phase commonly indicates a feature that affects use or management. For example, Alpha silt loam, 0 to 2 percent slopes, is a phase of the Alpha series.

Some map units are made up of two or more major soils or miscellaneous areas. These map units are complexes, associations, or undifferentiated groups.

A *complex* consists of two or more soils or miscellaneous areas in such an intricate pattern or in such small areas that they cannot be shown separately on the maps. The pattern and proportion of the soils or miscellaneous areas are somewhat similar in all areas. Alpha-Beta complex, 0 to 6 percent slopes, is an example.

An *association* is made up of two or more geographically associated soils or miscellaneous areas that are shown as one unit on the maps. Because of present or anticipated uses of the map units in the survey area, it was not considered practical or necessary to map the soils or miscellaneous areas separately. The pattern and relative proportion of the soils or miscellaneous areas are somewhat similar. Alpha-Beta association, 0 to 2 percent slopes, is an example.

An *undifferentiated group* is made up of two or more soils or miscellaneous areas that could be mapped individually but are mapped as one unit because similar interpretations can be made for use and management. The pattern and proportion of the soils or miscellaneous areas in a mapped area are not uniform. An area can be made up of only one of the major soils or miscellaneous areas, or it can be made up of all of them. Alpha and Beta soils, 0 to 2 percent slopes, is an example.

Some surveys include *miscellaneous areas*. Such areas have little or no soil material and support little or no vegetation. Rock outcrop is an example.

Additional information about the map units described in this report is available in other soil reports, which give properties of the soils and the limitations, capabilities, and potentials for many uses. Also, the narratives that accompany the soil reports define some of the properties included in the map unit descriptions.

Humboldt County, South Part, California

575—Canoecreek-Sproulsh-Redwohly complex, 50 to 75 percent slopes, warm

Map Unit Setting

National map unit symbol: 2ml28

Elevation: 100 to 3,280 feet

Mean annual precipitation: 59 to 100 inches

Mean annual air temperature: 48 to 55 degrees F

Frost-free period: 240 to 300 days
Farmland classification: Not prime farmland

Map Unit Composition

Canoecreek, warm, and similar soils: 45 percent
Sproullish, warm, and similar soils: 25 percent
Redwohly, warm, and similar soils: 15 percent
Minor components: 15 percent
*Estimates are based on observations, descriptions, and transects of
the mapunit.*

Description of Canoecreek, Warm

Setting

Landform: Mountain slopes
Landform position (two-dimensional): Backslope
Landform position (three-dimensional): Mountainflank
Down-slope shape: Linear
Across-slope shape: Convex
Parent material: Colluvium and residuum derived from sandstone,
mudstone, and conglomerate

Typical profile

O_i - 0 to 4 inches: gravelly slightly decomposed plant material
A - 4 to 13 inches: very gravelly loam
Bw₁ - 13 to 30 inches: very gravelly loam
Bw₂ - 30 to 47 inches: very gravelly loam
Bw₃ - 47 to 61 inches: very gravelly loam
Bw₄ - 61 to 71 inches: very gravelly loam

Properties and qualities

Slope: 50 to 75 percent
Surface area covered with cobbles, stones or boulders: 1.0 percent
Depth to restrictive feature: More than 80 inches
Drainage class: Well drained
*Capacity of the most limiting layer to transmit water
(K_{sat}):* Moderately high to high (0.60 to 2.00 in/hr)
Depth to water table: More than 80 inches
Frequency of flooding: None
Frequency of ponding: None
Maximum salinity: Nonsaline to very slightly saline (0.0 to 2.0
mmhos/cm)
Available water supply, 0 to 60 inches: Moderate (about 7.4
inches)

Interpretive groups

Land capability classification (irrigated): None specified
Land capability classification (nonirrigated): 7e
Hydrologic Soil Group: B
Ecological site: F004BJ102CA - Dry, steep mountain slopes
Hydric soil rating: No

Description of Sproulish, Warm

Setting

Landform: Mountain slopes
Landform position (two-dimensional): Backslope
Landform position (three-dimensional): Mountainflank
Down-slope shape: Linear
Across-slope shape: Linear
Parent material: Colluvium derived from mudstone and/or colluvium
derived from sandstone and/or residuum weathered from
mudstone and/or residuum weathered from sandstone

Typical profile

Oi - 0 to 2 inches: slightly decomposed plant material
A - 2 to 8 inches: gravelly loam
Bt1 - 8 to 16 inches: loam
Bt2 - 16 to 35 inches: loam
Bt3 - 35 to 55 inches: loam
Bt4 - 55 to 79 inches: gravelly loam

Properties and qualities

Slope: 50 to 75 percent
Surface area covered with cobbles, stones or boulders: 0.0 percent
Depth to restrictive feature: More than 80 inches
Drainage class: Well drained
Capacity of the most limiting layer to transmit water
(Ksat): Moderately high to high (0.20 to 2.00 in/hr)
Depth to water table: More than 80 inches
Frequency of flooding: None
Frequency of ponding: None
Maximum salinity: Nonsaline to very slightly saline (0.0 to 2.0
mmhos/cm)
Available water supply, 0 to 60 inches: High (about 10.1 inches)

Interpretive groups

Land capability classification (irrigated): None specified
Land capability classification (nonirrigated): 7e
Hydrologic Soil Group: B
Ecological site: F004BJ102CA - Dry, steep mountain slopes
Hydric soil rating: No

Description of Redwohly, Warm

Setting

Landform: Mountain slopes
Landform position (two-dimensional): Shoulder, backslope
Landform position (three-dimensional): Mountainflank
Down-slope shape: Convex
Across-slope shape: Convex
Parent material: Residuum weathered from sandstone and/or
residuum weathered from mudstone

Typical profile

- A - 0 to 8 inches: gravelly loam*
- Bt - 8 to 30 inches: very paragravelly loam*
- C - 30 to 79 inches: paragravel*

Properties and qualities

- Slope: 50 to 75 percent*
- Depth to restrictive feature: 20 to 39 inches to strongly contrasting textural stratification*
- Drainage class: Well drained*
- Capacity of the most limiting layer to transmit water (Ksat): Moderately low to moderately high (0.14 to 1.42 in/hr)*
- Depth to water table: More than 80 inches*
- Frequency of flooding: None*
- Frequency of ponding: None*
- Maximum salinity: Nonsaline to very slightly saline (0.0 to 2.0 mmhos/cm)*
- Available water supply, 0 to 60 inches: Low (about 3.7 inches)*

Interpretive groups

- Land capability classification (irrigated): None specified*
- Land capability classification (nonirrigated): 7e*
- Hydrologic Soil Group: B*
- Ecological site: F004BJ102CA - Dry, steep mountain slopes*
- Hydric soil rating: No*

Minor Components

Crazycoyote

- Percent of map unit: 7 percent*
- Landform: Mountain slopes*
- Landform position (two-dimensional): Backslope*
- Landform position (three-dimensional): Mountainflank*
- Down-slope shape: Concave, convex, linear*
- Across-slope shape: Linear*
- Hydric soil rating: No*

Caperidge, warm

- Percent of map unit: 5 percent*
- Landform: Ridges*
- Landform position (two-dimensional): Summit, shoulder*
- Landform position (three-dimensional): Mountaintop*
- Down-slope shape: Convex, linear*
- Across-slope shape: Linear, convex*
- Hydric soil rating: No*

Rock outcrop

- Percent of map unit: 3 percent*
- Landform: Mountain slopes*
- Landform position (two-dimensional): Backslope*
- Landform position (three-dimensional): Center third of mountainflank*
- Down-slope shape: Convex*

Across-slope shape: Convex
Hydric soil rating: No

Data Source Information

Soil Survey Area: Humboldt County, South Part, California
Survey Area Data: Version 10, Sep 6, 2021

HUMBOLDT COUNTY DEPARTMENT OF PUBLIC WORKS
ROAD EVALUATION REPORT

8.8_11247 Road
Evaluation Report
11.22.2019

PART A: *Part A may be completed by the applicant*

Applicant Name: Thomas Harwood APN: 220-081-016

Planning & Building Department Case/File No.: 11247

Road Name: Eubanks Road (complete a separate form for each road)

From Road (Cross street): Property Entrance

To Road (Cross street): Ettersburg-Honeydew Road

Length of road segment: 2.0 miles Date Inspected: _____

Road is maintained by: County Other _____
(State, Forest Service, National Park, State Park, BLM, Private, Tribal, etc)

Check one of the following:

Box 1 The entire road segment is developed to Category 4 road standards (20 feet wide) or better. If checked, then the road is adequate for the proposed use without further review by the applicant.

Box 2 The entire road segment is developed to the equivalent of a road category 4 standard. If checked, then the road is adequate for the proposed use without further review by the applicant.

An equivalent road category 4 standard is defined as a roadway that is generally 20 feet in width, but has pinch points which narrow the road. Pinch points include, but are not limited to, one-lane bridges, trees, large rock outcroppings, culverts, etc. Pinch points must provide visibility where a driver can see oncoming vehicles through the pinch point which allows the oncoming vehicle to stop and wait in a 20 foot wide section of the road for the other vehicle to pass.

Box 3 The entire road segment is not developed to the equivalent of road category 4 or better. The road may or may not be able to accommodate the proposed use and further evaluation is necessary. Part B is to be completed by a Civil Engineer licensed by the State of California.

The statements in PART A are true and correct and have been made by me after personally inspecting and measuring the road. A map showing the location and limits of the road being evaluated in PART A is attached.

DocuSigned By:
Thomas Harwood
3E93AD1C4C4A485...
Signature
Thomas Harwood

11/22/19
Date

Name Printed

Important: Read the instructions before using this form. If you have questions, please call the Dept. of Public Works Land Use Division at 707.445.7205.

PART B: Only complete Part B if Box 3 is checked in Part A. Part B is to be completed by a Civil Engineer licensed by the State of California. Complete a separate form for each road.

Road Name: _____ Date Inspected: _____ APN: _____
From Road: _____ (Post Mile _____) Planning & Building
To Road: _____ (Post Mile _____) Department Case/File No.: _____

1. What is the Average Daily Traffic (ADT) of the road (including other known cannabis projects)?
Number of other known cannabis projects included in ADT calculations:
(Contact the Planning & Building Department for information on other nearby projects.) _____

ADT: _____ Date(s) measured: _____

Method used to measure ADT: Counters Estimated using ITE Trip Generation Book

Is the ADT of the road less than 400? Yes No

If YES, then the road is considered very low volume and shall comply with the design standards outlined in the American Association of State Highway and Transportation Officials (AASHTO) Guidelines for Geometric Design of Very Low-Volume Local Roads (ADT ≤400). Complete sections 2 and 3 below.

If NO, then the road shall be reviewed per the applicable policies for the design of local roads and streets presented in AASHTO A Policy on Geometric Design of Highways and Streets, commonly known as the "Green Book". Complete section 3 below.

2. Identify site specific safety problems with the road that include, but are not limited to: (Refer to Chapter 3 in AASHTO Guidelines for Geometric Design of Very Low-Volume Local Roads (ADT ≤400) for guidance.)
- A. Pattern of curve related crashes.
Check one: No. Yes, see attached sheet for Post Mile (PM) locations.
 - B. Physical evidence of curve problems such as skid marks, scarred trees, or scarred utility poles
Check one: No. Yes, see attached sheet for PM locations.
 - C. Substantial edge rutting or encroachment.
Check one: No. Yes, see attached sheet for PM locations.
 - D. History of complaints from residents or law enforcement.
Check one: No. Yes (check if written documentation is attached)
 - E. Measured or known speed substantially higher than the design speed of the road (20+ MPH higher)
Check one: No. Yes.
 - F. Need for turn-outs.
Check one: No. Yes, see attached sheet for PM locations.

3. Conclusions/Recommendations per AASHTO. Check one:

The roadway can accommodate the cumulative increased traffic from this project and all known cannabis projects identified above.

The roadway can accommodate the cumulative increased traffic from this project and all known cannabis projects identified above, if the recommendations on the attached report are done. (check if a Neighborhood Traffic Management Plan is also required and is attached.)

The roadway cannot accommodate increased traffic from the proposed use. It is not possible to address increased traffic.

A map showing the location and limits of the road being evaluated in PART B is attached. The statements in PART B are true and correct and have been made by me after personally evaluating the road.

DocuSigned by:

Thomas Harwood

11/22/19

Signature of Civil Engineer

Date

Important: Read the instructions before using this form. If you have questions, please call the Dept. of Public Works Land Use Division at 707.445.7205.



- | | |
|---------------|--------------------|
| 1.) START | 4.) .90 MILES |
| 2.) .30 MILES | 5.) 1.0 MILES |
| 3.) .60 MILES | 6.) END, 1.1 MILES |



SEGMENT 1, EUBANKS ROAD:



APPROXIMATE SCALE (FT.)



Thomas Harwood, Lost Coast Elixers, LLC- ROAD EVALUATION



HUBER C&D
www.hubercad.com

REVISION: **-A-**

DRAWN BY: RHUBER
DATE: 10/22/19

APN 220-081-016:
APPS# 11247



POINT 1: START, GATED ENTRY TO PROPERTY

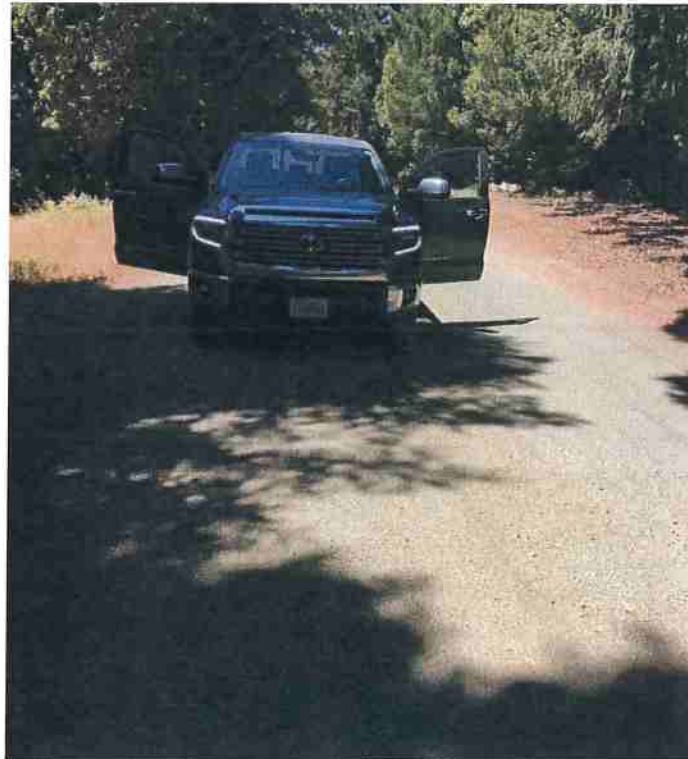

POINT 2: .30 MILES FROM START ON EUBANKS ROAD

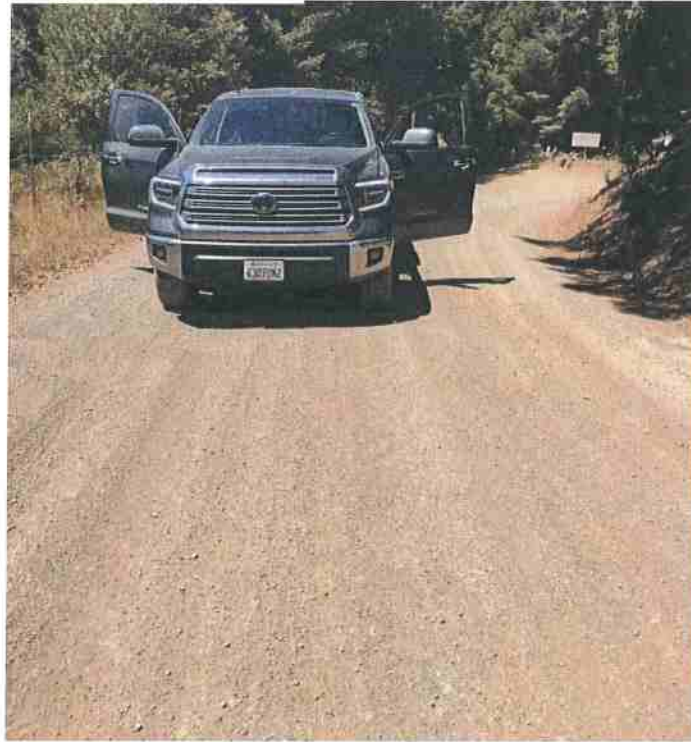

POINT 3: .60 MILES FROM START,



POINT 4: .90 MILES FROM START, EUBANKS ROAD



POINT 5: 1.0 MILES FROM START, EUBANKS ROAD



**POINT 6: END, 1.10 MILES FROM START,
INTERSECTION, EUBANKS TO ETTERSBERG ROAD**

- ① CE 1/16: Found 5/8" rebar tagged L.S. 2786, 10¹⁵ ft South of the true corner position as described in Book 43 of Surveys, Page 18, H.C.R.
- ② CS 1/16: Found 1/2" iron pipe tagged L.S. 4277, with bearing trees in good condition as described in Book 47 of Surveys, Page 87, H.C.R.
- ③ SW 1/16: I set a 3/4" iron pipe with a plastic plug stamped L.S. 6734 on a steep southeast facing slope in a southwesterly trending ravine. I faced & tagged: a 12" madrone bears S 87° W, 7⁶ ft. and an 18" tan oak bears N 02° E, 47² ft.
- ④ CW 1/16: I set a 3/4" iron pipe with a plastic plug stamped L.S. 6734 on a gentle north slope, ± 50 ft south of an E-W road. I faced & tagged: a 12" tan oak, N 19⁶° E, 2⁹ ft., and a 24" madrone, S 42° E, 4⁹ ft.

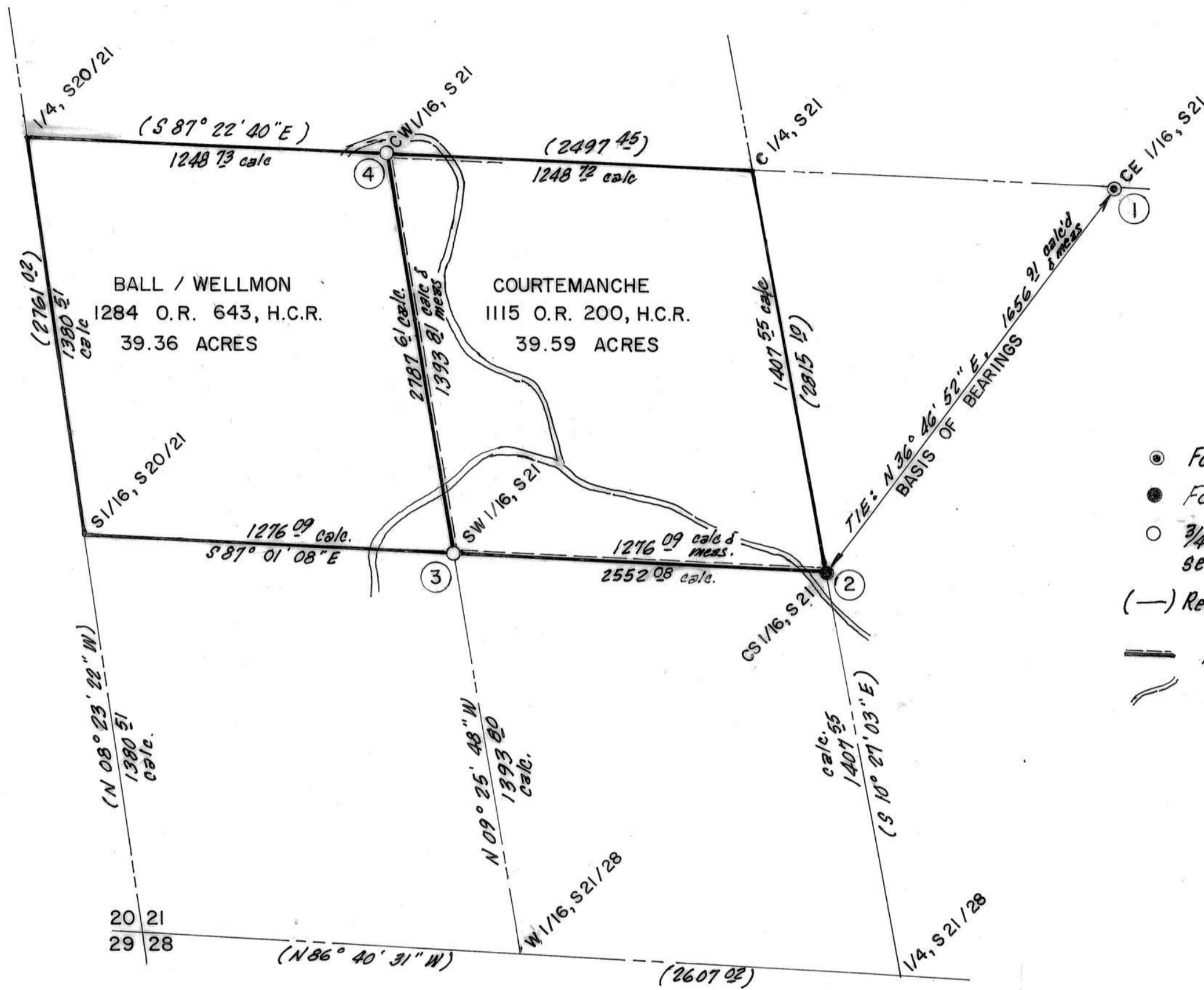

LEGEND

- Found 5/8" rebar & cap stamped L.S. 2786
- Found 1/2" iron pipe & plug stamped L.S. 4277
- 3/4" iron pipe with plug stamped L.S. 6734 set this survey
- (—) Record Data (Book 43 of Surveys, Pgs. 17 & 18)
- Property Boundary marked with both this survey
- Travelled roadway (not described hereon)



BASIS OF BEARINGS

Tie between CE 1/16 and CS 1/16 calculated from record data per Book 47 of Surveys, Page 87, H.C.R. Tie shown is to true corner positions. The subdivision of the southwest quarter of Section 21 shown hereon is calculated from record data per Book 43 of Surveys, Pages 17 & 18, H.C.R.

COUNTY SURVEYOR'S STATEMENT

This map has been examined in accordance with Section 8766 of the Land Surveyor's Act this 14th day of January, 1994.

Signed & Sealed: Peter M. Rei DEPUTY FOR JOHN ELLIS MURRAY
 L.S. / RCE No.: 5963
 License expires: 12/31/96



1994-1917
 COUNTY RECORDER'S STATEMENT

Filed this 19th day of January 1994 at 4:06 p.m. in Book 54 of Surveys, Page 182, Humboldt County Records at the request of Thomas N. Stephens County Recorder, Humboldt Co.

By: M. Hedderley Deputy
 Fee: \$6.00

SURVEYOR'S STATEMENT

This map correctly represents a survey made by me or under my direction in conformance with the requirements of the Land Surveyors Act at the request of Steve Ball & Lori Courtemanche in March, 1993.

Signed & Sealed: Thomas N. Stephens
 Thomas N. Stephens L.S. 6734
 License expires: 9/30/96



RECORD OF SURVEY FOR BALL & COURTEMANCHE

IN THE UNINCORPORATED AREA OF THE COUNTY OF HUMBOLDT, STATE OF CALIFORNIA IN SECTION 21, T. 4 S. - R. 2 E., H.B. & M. SCALE: 1 in = 400 ft.

SEPTEMBER, 1993

SHEET 1 OF 1 SHEETS

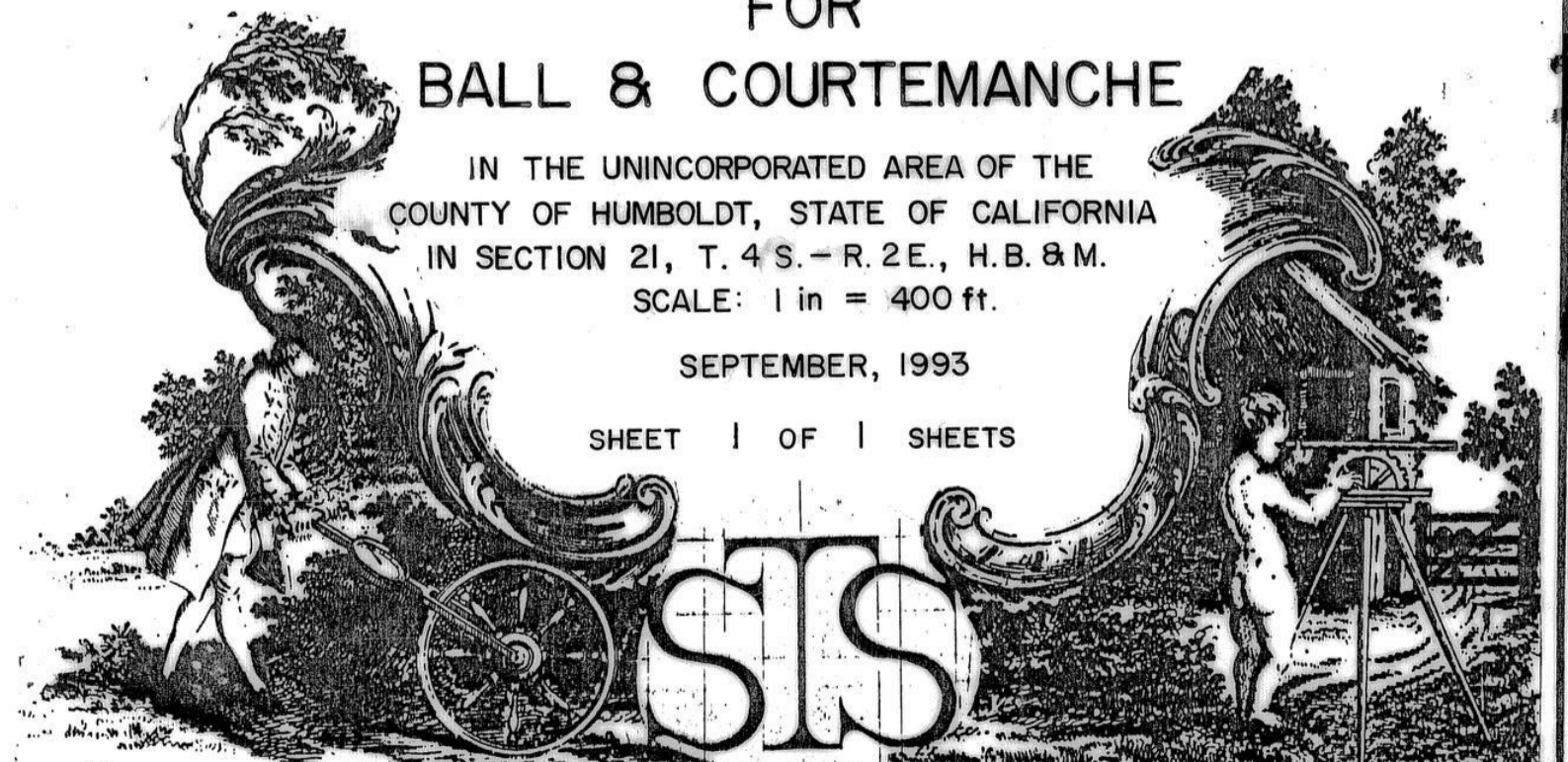

STEPHENS TECHNICAL SERVICE
 3501 Redwood Drive, Suite 2/P.O. Box 2141, Redway CA 95560 (707) 923-2199



State of California – Natural Resources Agency
DEPARTMENT OF FISH AND WILDLIFE
Region 1 - Northern
619 Second Street
Eureka, California 95501
(707) 445-6493
www.wildlife.ca.gov

EDMUND G. BROWN, Jr., Governor
CHARLTON H. BONHAM, Director



8.10_11247 Notice of Violation

May 18, 2018

Mr. Thomas Harwood
PO Box 264
Redway, CA 95560

Subject: Notice of Violation of Fish and Game Code Section 1602
Notification No. 1600-2016-0436-R1

Dear Mr. Harwood:

On April 24, 2018, Department of Fish and Wildlife (Department) Senior Environmental Scientist Specialist Ryan Bourque and Fish and Wildlife Warden Joshua Zulliger visited your property at Assessor's Parcel Number (APN) 220-081-016 (Property) within the Eubank Creek watershed, County of Humboldt, State of California to conduct a compliance inspection. During the visit, the Department staff observed the following activities subject to Fish and Game Code (FGC) Section 1602.

- Water diversions from unnamed tributaries to Eubank Creek
- Unpermitted stream crossing
- Water pollution from (1) deposition of sediment (a material deleterious to fish and wildlife), potting soil, and cannabis stems into waters of the state and (2) placement of sediment, potting soil, and cannabis stems where it can pass into waters of the state.
- Deposition of cut logs into waters of the state.

The Department has determined that the items described below are in violation of FGC Section 1602. The purpose of this letter is to describe the violations and to provide you an opportunity to correct them voluntarily.

On June 26, 2017, the Department issued you a Streambed Alteration Agreement (Agreement) (No. 1600-2016-0436-R1) for four encroachments; two water diversions and two remediation sites. Select aspects of the projects included in the Agreement are still in progress. However, the Agreement required the following upon execution of the Agreement:

- Work Period (Measure 2.2). All work, not including water diversion, shall be confined to the period **August 1 through October 1 of 2017**. Work on stream banks or within the active channel of a stream shall be restricted to periods of **dry weather**. Precipitation forecasts and potential increases in

Conserving California's Wildlife Since 1870

stream flow shall be considered when planning construction activities. Construction activities shall cease and all necessary erosion control measures shall be implemented prior to the onset of precipitation.

- Measurement of Diverted Flow (Measure 2.6). The Permittee shall install a device acceptable to CDFW for measuring the quantity of water diverted from each POD. This measurement shall begin as soon as this Agreement is signed by the Permittee. The Permittee shall record the quantity of water pumped to and from the system on a weekly basis. Alternatively, the Permittee can record the frequency of pumping and the time to fill storage.
- Water Management Plan (Measure 2.7). The Permittee shall submit a Water Management Plan no later than June 30, 2017, that describes how compliance will be achieved under this Agreement. The Water Management Plan shall include details on water storage, water conservation, or other relevant material to maintain water needs in coordination with diversion minimization and bypass flow requirements. The Water Management Plan shall include a brief narrative describing water use on the property, photographs to support the narrative, and water use calculations to ensure compliance with this Agreement. The Water Management Plan shall be submitted to CDFW at 619 Second Street, Eureka, CA 95501.
- Intake Screening (Measure 2.9) Screens shall be installed on intakes wherever water is diverted, and shall be in place whenever water is diverted. Openings in intakes shall not exceed 1/8 inch diameter (horizontal for slotted or square openings) or 3/32 inch for round openings. The Permittee shall regularly inspect, clean, and maintain screens in good condition.
- Water Storage Maintenance (Measure 2.12). Storage tanks shall have a float valve to shut off the diversion when tanks are full to prevent overflow from being diverted when not needed. The Permittee shall install any other measures necessary to prevent overflow of tanks resulting in more water being diverted than is used.
- Runoff (Measure 2.16). The Permittee shall not allow silt or nutrient laden runoff to enter the stream or be directed to where it may enter the stream. Erosion control measures, such as, silt fences, straw hay bales, infiltration galleries, swales, gravel or rock lined ditches, water check bars, and broadcasted weed-free straw shall be used where ever storm water runoff has the potential to enter any waterway.
- Runoff from Steep Areas (Measure 2.17). Permittee shall make preparations so that runoff will be diverted into stable areas with little

Mr. Thomas Harwood
May 18, 2018
Page 3 of 5

erosion potential or contained behind erosion control structures. Erosion control structures such as straw bales and/or siltation control fencing shall be placed and maintained until the threat of erosion ceases.

- Erosion Control Maintenance (Measure 2.18). Permittee shall periodically monitor and make modifications, repairs and improvements to erosion control measures whenever it is needed.
- Project Inspection (Measure 2.20). All projects shall be inspected by Timberland Resource Consulting or a licensed engineer to ensure that the proposed project was implemented as designed. The inspection report shall include photographs of the site and shall be submitted to CDFW within 90 days of project completion.

Department staff observed (1) no flow meter installed on either diversion, (2) no float valve installed on and a crack with water leaking from the storage tank receiving water from the diversions, (3) inadequate screen attached to the spring box outlet, (4) failure to complete POD3 removal by agreed deadline, (5) failure to record and report the quantity of water used from the diversions, (6) failure to submit a water management plan, (7) failure to submit project inspection report, (8) silt and nutrient laden runoff entry into a stream and placement of potting soil and cannabis stems where they may enter a stream, (9) failure to notify for a stream crossing encroachment prior to conducting work, and (10) firewood rounds from upslope clearing abandoned in a stream. Because of these observations, the project violates the requirement in Fish and Game Code section 1602 that a project be conducted in accordance with an approved Agreement.

Based on the above, you will need to correct these violations by (1) installing a flow meter on each water diversion to comply with Measure 2.6, (2) installing a float valve and repair or replace water tank to comply with Measure 2.12, (3), installing a screen to comply with Measure 2.9, (4) removing POD3 and all trash in the stream or with the potential to enter the stream, (5) recording and reporting the quantity of water used from each water diversion, (6) submitting a water management plan to comply with Measure 2.7, (7) submitting a project inspection report to comply with Measure 2.20, (8) remove potting soil from current location and install adequate road drainage structure to comply with measures 2.16-2.18, (9) submitting a major amendment to your Agreement and pay the applicable fee, and (10) remove firewood rounds abandoned in the stream. The Department requests that items 1-4, 8, and 10 be corrected **within 15 days** and that items 5-7 and 9 be corrected **within 45 days** from the date of this letter.

Please respond in writing to the Department's proposal and provide proof (e.g., pictures) that the requested items have been corrected. If the Department does not receive a response by the dates requested above, the Department may pursue other options including cancellation of the Agreement or referring the matter to the District Attorney's Office or the Attorney General's Office for civil or criminal prosecution.

Mr. Thomas Harwood
May 18, 2018
Page 4 of 5

A person who violates FGC sections 1602 in conjunction with the cultivation or production of marijuana is subject to significant penalties or fines. Specifically, the Department may impose civil penalties administratively against any person found by the Department to have violated this FGC section in connection with the production or cultivation of marijuana following a complaint and, if requested, a hearing.

The Department may request a maximum civil penalty of \$8,000 for each violation of FGC section 1602. Each day the violation occurs or continues to occur constitutes a separate violation. (Fish & G. Code, § 12025, subds. (b)(1)(A), (2); (e)). Also, the District Attorney or the Attorney General may enforce a violation of FGC section 1602 civilly. Specifically, under FGC sections 1615, a person who violates FGC section 1602 is subject to a maximum civil penalty of \$25,000 for each violation. The District Attorney or the Attorney General may also enforce a violation of FGC sections 1602 criminally. Under FGC section 12000, each violation is a misdemeanor.

If you have any questions regarding this letter, please contact Ryan Bourque at 707-441-2064 or by email at ryan.bourque@wildlife.ca.gov.

The Department appreciates your cooperation and encourages you to respond to this notice to limit any damage to resources.

Sincerely,

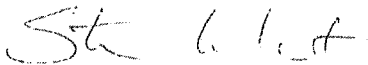

Lieutenant Steve White
Watershed Enforcement Team

cc: Steve White, Joshua Zulliger, Scott Bauer, Curt Babcock, Jeremy Valverde, Laurie Harnsberger, and Ryan Bourque
Department of Fish and Wildlife
steve.white@wildlife.ca.gov, joshua.zulliger@wildlife.ca.gov,
scott.bauer@wildlife.ca.gov, curt.babcock@wildlife.ca.gov,
jeremy.valverde@wildlife.ca.gov, laurie.harnsberger@wildlife.ca.gov, and
ryan.bourque@wildlife.ca.gov

Chris Carroll and Ron Pelletier
Timberland Resource Consultants
carroll@timberlandresource.com and rpelletier@timberlandresource.com

Mr. Thomas Harwood
May 18, 2018
Page 5 of 5

Paul Hagen
North Coast Environmental Law Office
paul@northcoastelaw.com

Steven Santos, John Ford, and Robert Russell
Humboldt County Planning and Building Department
santos@co.humboldt.ca.us, jford@co.humboldt.ca.us, and
rrussell@co.humboldt.ca.us

North Coast Environmental Law Office

June 4, 2018

8.11_11247 North Coast Env
Law Office Letter 6.4.2018

Lieutenant Steve White
Department of Fish and Wildlife
619 Second Street
Eureka, CA 95501

**Re: *Response to 5-18-18 NOV Notification No. 1600-2016-0436-R1, Harwood
APN 220-081-016***

VIA EMAIL

Dear Lt. Steve White,

This letter reports in response to your Notice of Violation letter, notification number 1600-2016-0436-R1, sent May 18, 2018 to Thomas Harwood regarding his property known as APN 220-081-016. That NOV letter required a response to its 'Items 1-4, 8 and 10' within 15 days of its May 18th date.

The May 18th NOV letter lists specific items of concern to the Department of Fish and Wildlife subsequent to a site visit on April 24th by DFW staff. The letter states:

"The Department requests that items 1-4, 8, and 10 be corrected **within 15 days** and that items 5-7 and 9 be corrected **within 45 days** from the date of this letter. [¶] Please respond in writing to the Department's proposal and provide proof (e.g., pictures) that the requested items have been corrected."

This letter of June 4th follows a preliminary email from Brian Thomason to you, sent June 2, 2018 responding to the NOV letter, and serves as a more formal report in response to the department's request. Mr. Harwood has employed a substantial number of people and resources to remediate the site in direct response to the department's requirements. Mr. Thomason is an agent of Mr. Harwood's who assisted in performing the work required to respond to the NOV, and to produce the thirteen photos submitted with his June 2nd email, which reads as follows:

"Dear Lieutenant Steve White,

Items 1-4 and 10 have been completed. Please see attached photos for verification.

Item 8 has been and is currently in an expedited manner. Item 8 was considerable to accomplish in the allotted time. Photos will be presented for Item 8 once completed as instructed.

Any questions or if any further photographic evidence desired, please let us know."

This letter augments Thomason's June 2nd email, and is intended to serve as a formal report in response to the department's NOV. Attached to the email transmitting this letter is a

June 4, 2018

Re: Response to 5-18-18 NOV Notification No. 1600-2016-0436-R1, Harwood APN 220-081-016

pdf file titled "Initial Response, DFW NOV, Ettersburg," containing the 13 photographs Thomason sent on June 2nd, which depict various before and after proofs of item corrections as requested by the department's NOV.

The 13 photographs have been arranged into a slide format, each appearing with a short caption which is shown in the table below. The table provides a comment explaining the activity undertaken to achieve the result depicted in each photo.

#	Item	Slide Caption	Comment
1	<u>Item #1</u> : "no flow meter installed on either diversion"	Item 1: Flow Meter Tank	A flow meter has been installed on the tank and is working properly
2	Item #1	Item 1: Wellhead at Greenhouses 1, 2, and 3	A flow meter has been installed at the wellhead and is working properly
3	Item #1	Item 1: Wellhead at Greenhouses 4 and 5	A flow meter has been installed at the wellhead and is working properly
4	Item #1	See above, #3	See above, #3
5	Item #1	Item 1: Wellhead at Greenhouses 1, 2, and 3	A flow meter has been installed at the wellhead and is working properly
6	Item #1	Item 1: Wellhead on the flat by the container	A flow meter has been installed at the wellhead and is working properly
7	Item #1	See above, #6	See above, #6
8	<u>Item #2</u> : "no float valve installed on and a crack with water leaking from the storage tank receiving water from the diversions"	Item 2: Float Valve	A float valve has been installed on the storage tank receiving water diversions and is working properly
9	Item #2	Item 2: Tank Repair	The crack on the storage tank receiving water diversions is repaired and the tank no longer leaks
10	<u>Item #3</u> : "inadequate screen attached to the spring box outlet"	Item 3: Screen, Eighth Inch	A screen sufficient to handle the spring box flow has been installed and is working properly
11	<u>Item #4</u> : "failure to complete POD3 removal by agreed deadline"	Item 4: POD 3 Trash	POD 3 trash removal per Agreement is now complete
12	<u>Item #10</u> : "firewood rounds from upslope clearing abandoned in a stream"	Item 10: Rounds cut and removed	Impacted area of affected stream is now remediated per NOV
13	Item #10	Item 10: Rounds removed	Impacted area of affected stream is now remediated per NOV

Page 3

June 4, 2018

Re: Response to 5-18-18 NOV Notification No. 1600-2016-0436-R1, Harwood APN 220-081-016

If this information is not sufficient to satisfy the department's concerns, please let me know. I will be happy to provide what the department needs.

This leaves the following items to be corrected within 45 days of the NOV letter's date:

- 5) failure to record and report the quantity of water used from the diversions,
- 6) failure to submit a water management plan,
- 7) failure to submit project inspection report, and
- 9) failure to notify for a stream crossing encroachment prior to conducting work

We will be providing the requested information to the department for these four items within the 45-day period.

If I can be of any assistance to you, please do not hesitate to contact me.

Thank you very much.

/s/ Paul Hagen

Attachment: "Initial Response, DFW NOV, Ettersburg" pdf file

cc: DFW Senior Environmental Scientist Specialist Ryan Bourque; et al

Item 1: Flow Meter Tank



Item 1: Wellhead at Greenhouses 1, 2, and 3





Item 1: Wellhead at Greenhouses 4 and 5

Item 1: Wellhead at Greenhouses 4 and 5



Item 1: Wellhead at Greenhouses 1, 2, and 3



Item 1: Wellhead on the flat by the container



Item 1:
Wellhead on
the flat by
the container



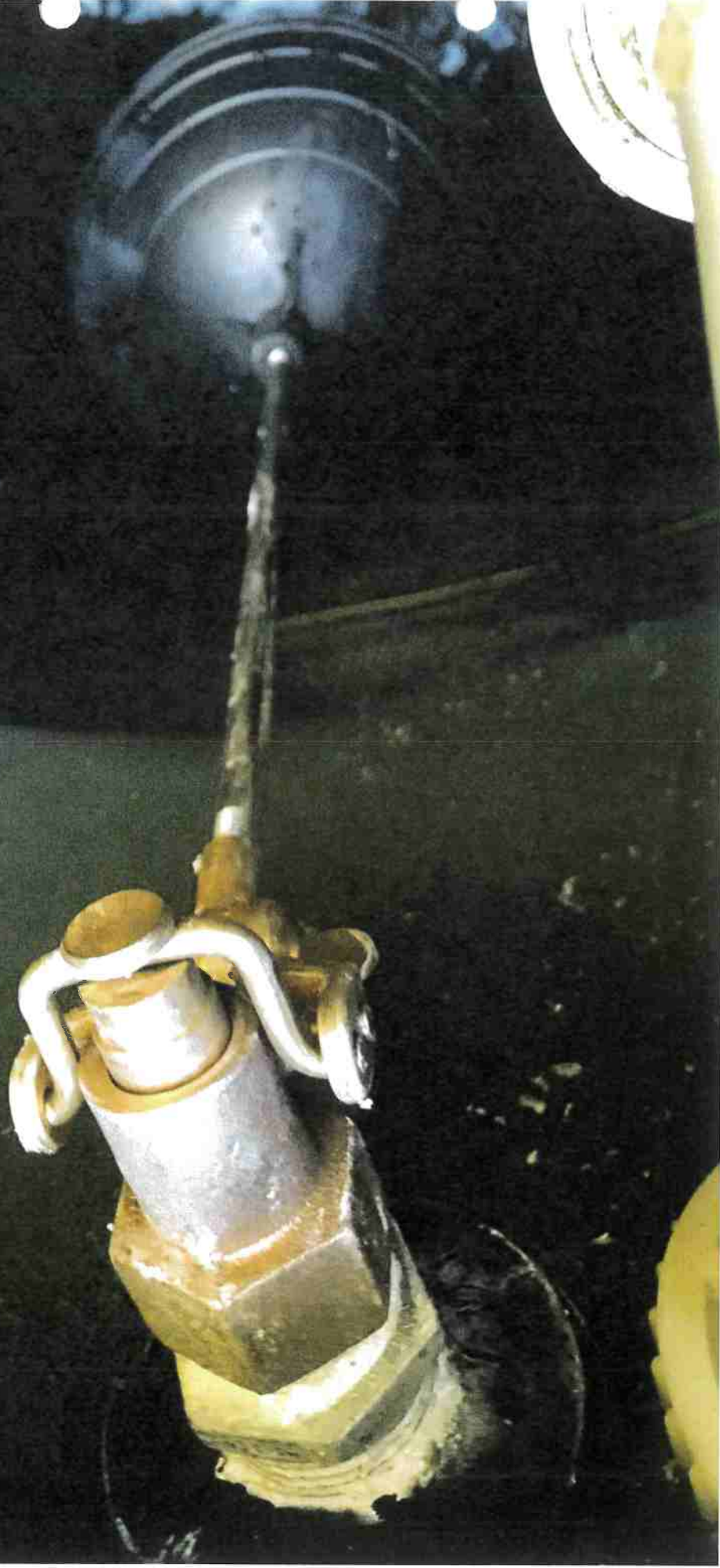

Item 2: Float Valve

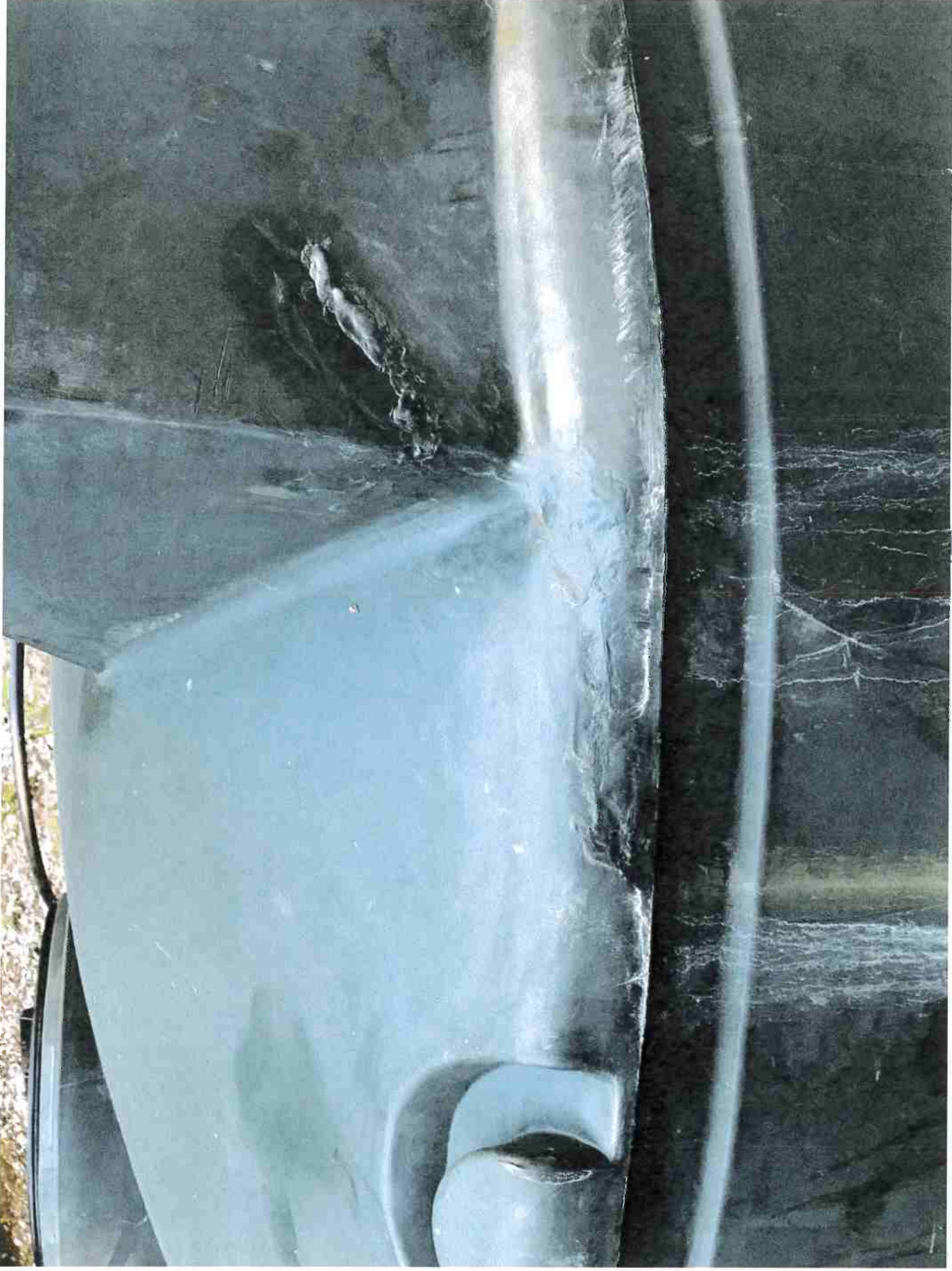

Item 2: Tank Repair

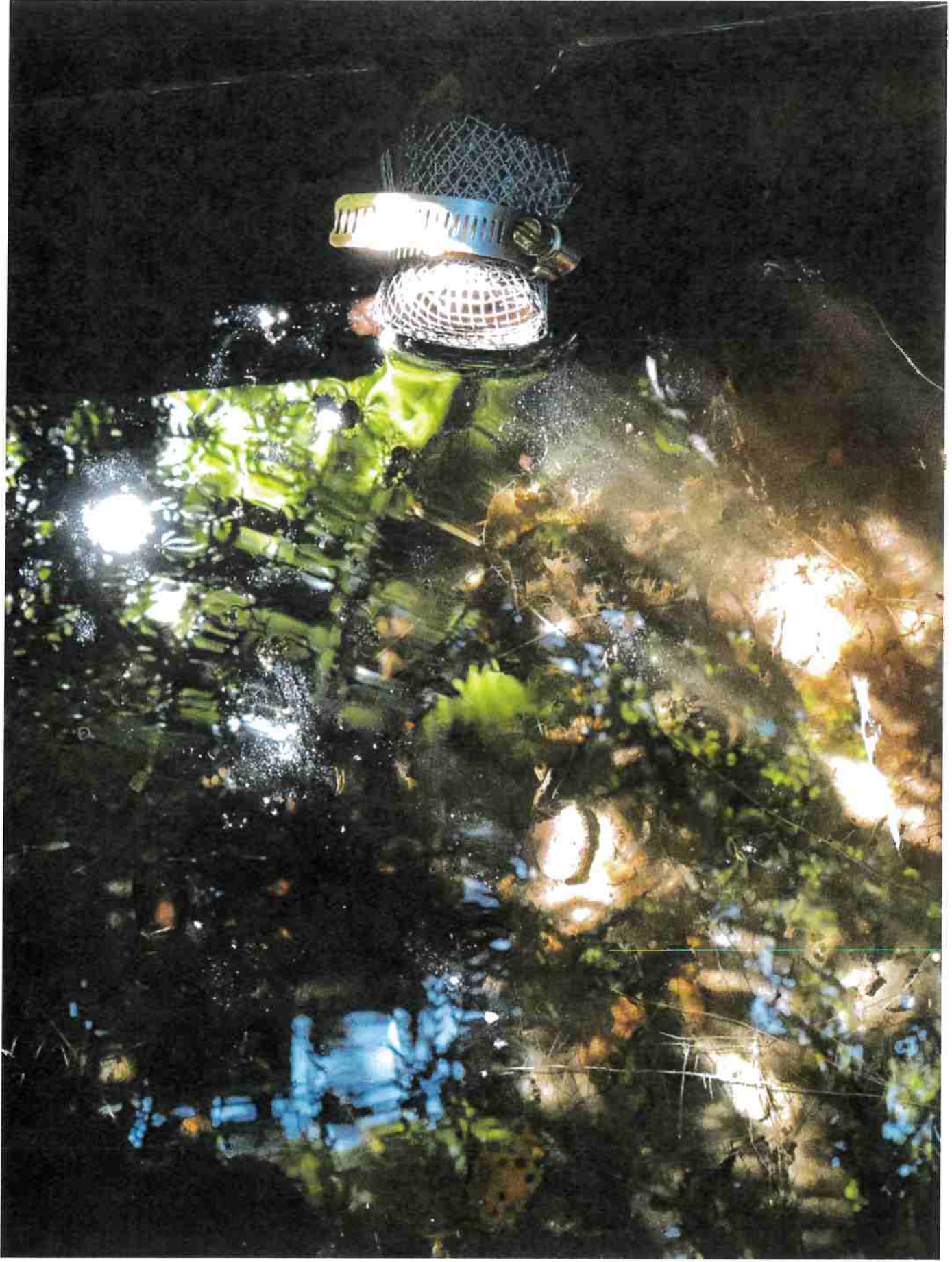

Item 3: Screen, Eighth Inch

Item 4:
POD 3
Trash



Item 10: Rounds cut and removed



Item 10:
Rounds
removed

